

SERIES 61K
High Resolution, 4-Pin

FEATURES

- 25, 32, 50, 64, 100, 128 and 256 Cycles per Revolution Available
- Sealed Version Available
- Rugged Construction
- Cable or Pin Versions
- 10 Million Rotational Life Cycles
- 300 RPM Shaft Rotation



DIMENSIONS in inches (and millimeters)

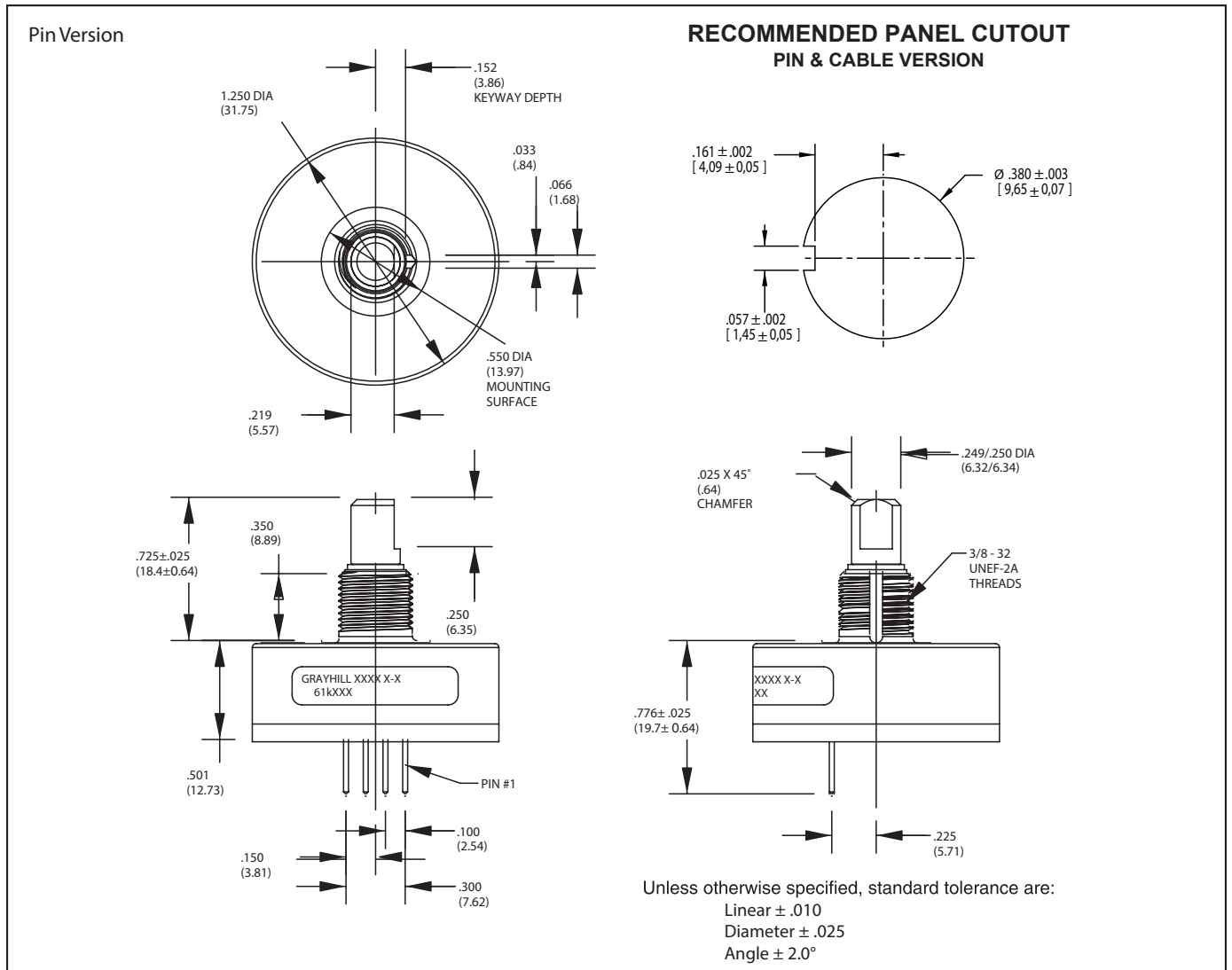

Optical and Mechanical Encoders



Optical Encoders

DIMENSIONS in inches (and millimeters)

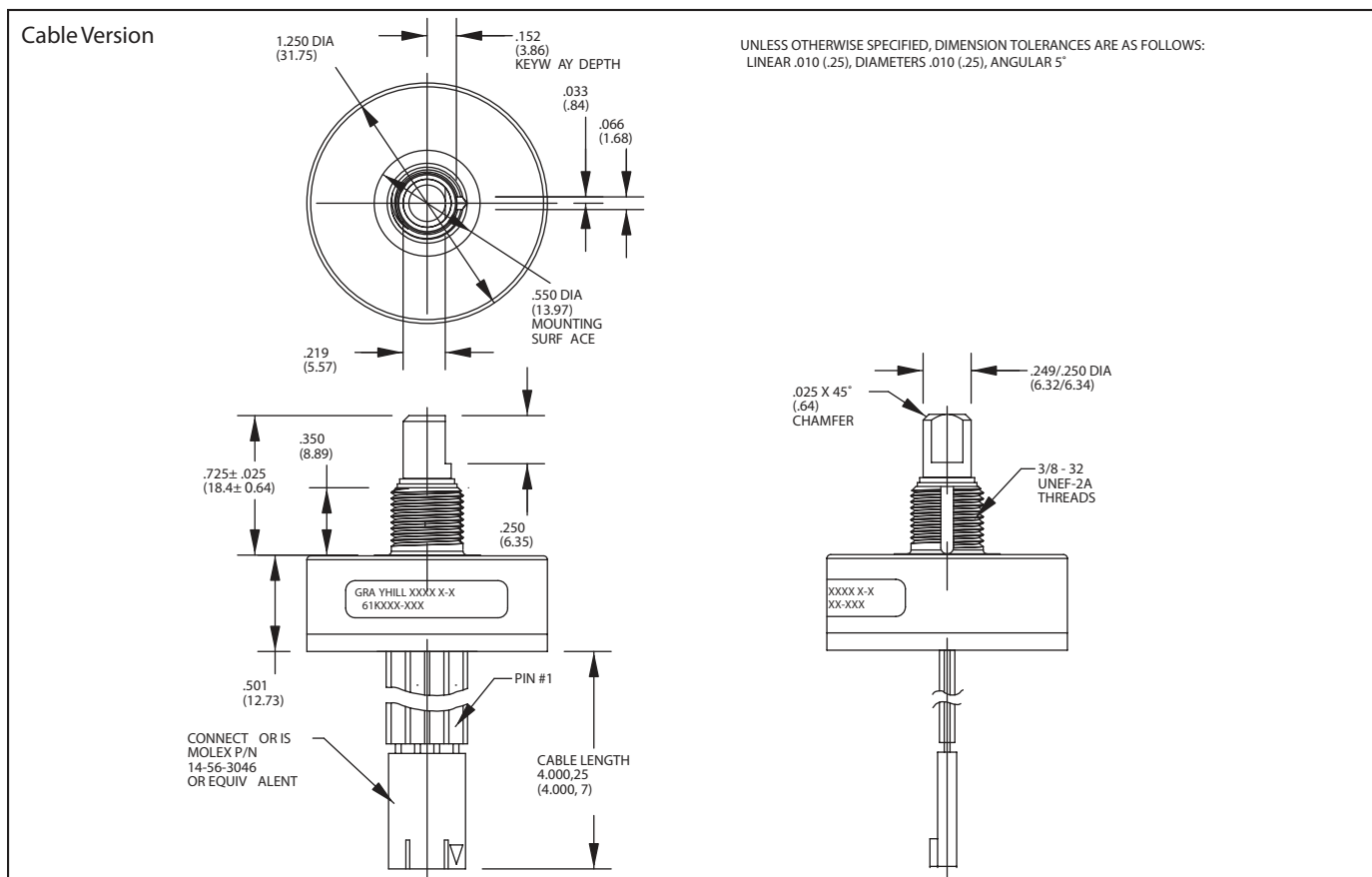

CIRCUITRY , TRUTH TABLE, AND WAVEFORM : Standard Quadrature 2-Bit Code

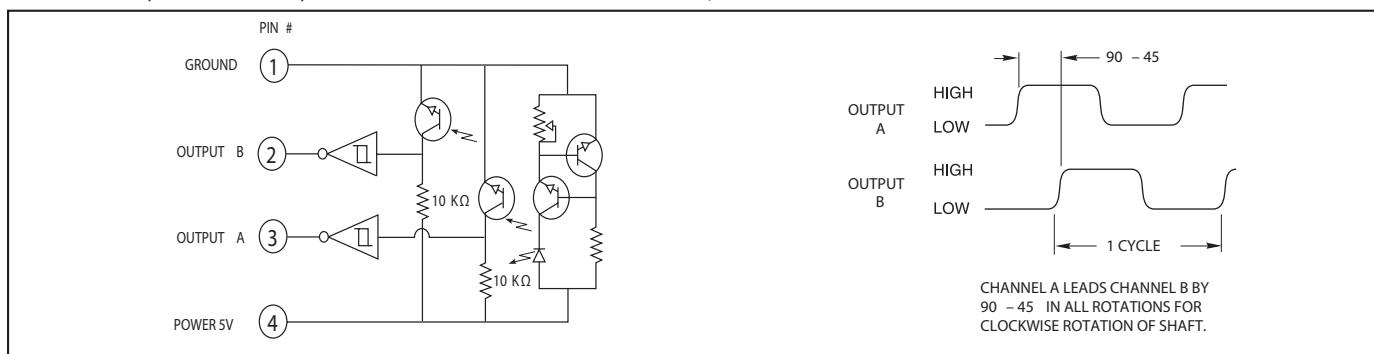

SPECIFICATIONS

Electrical Ratings

Operating Voltage: 5.0 ± .25 Vdc
Supply Current: 30 mA maximum at 5 Vdc
Logic Output Characteristics:
Output Type: Open collector with integrated Schmitt Trigger and 10K ohms pull-up resistor
Maximum Sink Current: 16 mA at .40 volts
Power Consumption: 150 mW maximum
Optical Rise Time: 500 nS typical
Optical Fall Time: 16 nS typical

Mechanical Ratings

Mechanical Life: 10 million revolutions
Time Life: Guaranteed for 10 years of continuous operation (calculated from emitter degradation data)
Mounting Torque: 20 in-lbs maximum
Shaft Push Out Force: 100 lbs
Terminal Strength: 5 lbs terminal pull-out force minimum
Solderability: 95% free of pin holes and voids
Operating Torque: 1.5 in-oz maximum (no detents) for unsealed versions

Environmental Ratings

Operating Temperature Range: -40°C to 85°C
Storage Temperature Range: -55°C to 100°C
Relative Humidity: 90-95% at 40°C for 96 hours
Vibration Resistance: Harmonic motion with amplitude of 15g, within a varied 10 to 2000 Hz frequency for 12 hours per MIL-STD-202, Method 204
Mechanical Shock: Test 1: 100g for 6 mS, half-sine wave with velocity change of 12.3 ft/s. Test 2: 100g for 6 mS, sawtooth wave with velocity change of 9.7 ft/s.
Shaft Seal: IP67 (61KS only)

SERIES 61R High Resolution, 5-Pin (Polarized Connection)

FEATURES

- 25, 32, 50, 64, 100, 128 and 256 Cycles per Revolution Available
- Sealed Version Available
- Rugged Construction
- Cable or Pin Version
- 10 Million Rotational Cycles
- 300 RPM Shaft Rotation
- Index Pulse Available



DIMENSIONS in inches (and millimeters)

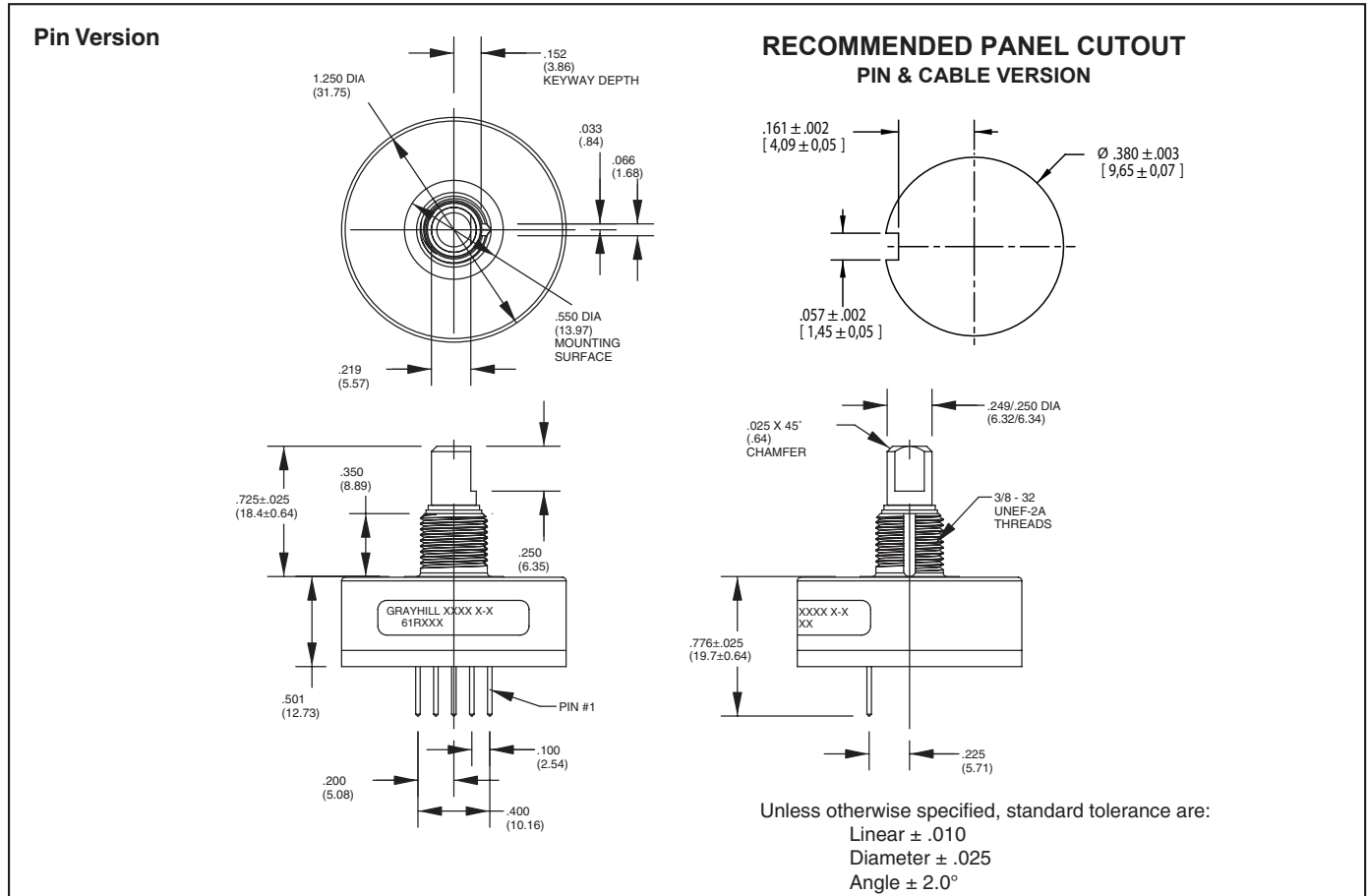

Optical and Mechanical Encoders



Optical Encoders

DIMENSIONS in inches (and millimeters)

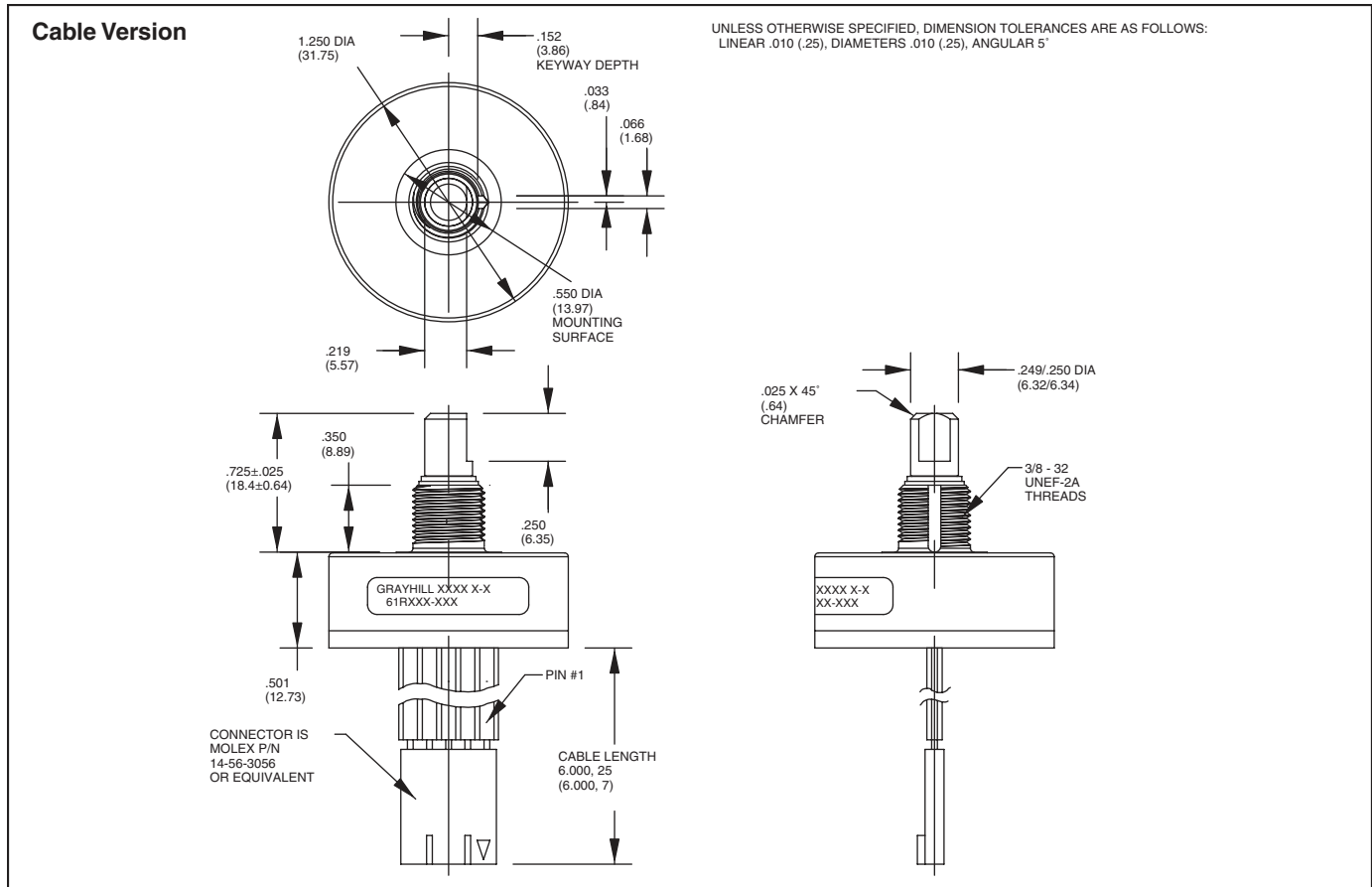

Optical and Mechanical Encoders

CIRCUITRY, TRUTH TABLE, AND WAVEFORM: Standard Quadrature 2-Bit Code

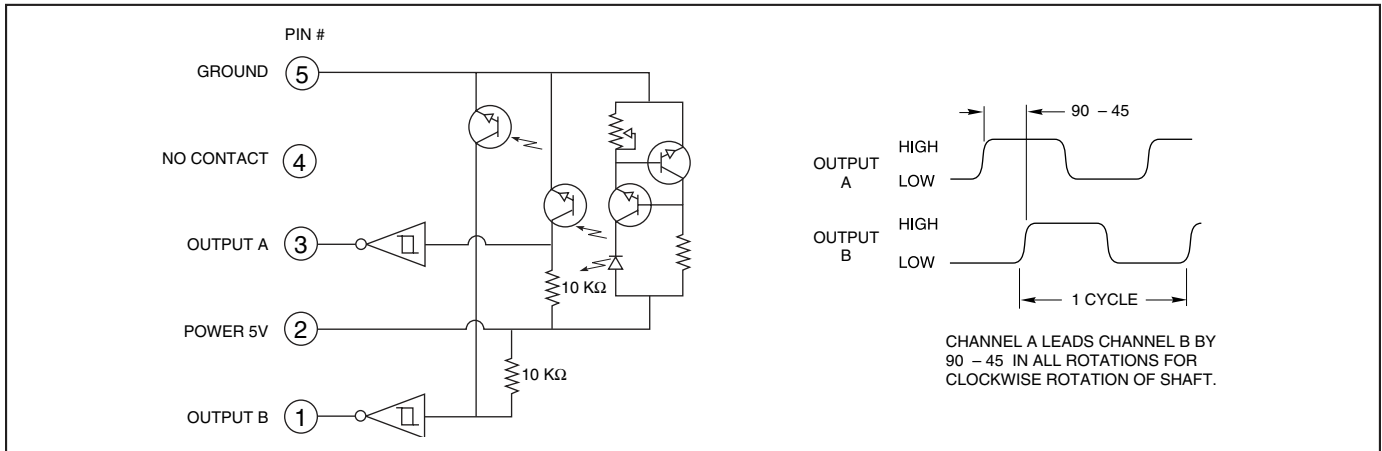

SPECIFICATIONS

Electrical Ratings

Operating Voltage: 5.0 ± .25 Vdc
Supply Current: 30 mA maximum at 5 Vdc
Logic Output Characteristics:
 Output Type: Open collector with integrated Schmitt Trigger and 10K ohms pull-up resistor
 Maximum Sink Current: 16 mA at .40 volts
Power Consumption: 150 mW maximum
Optical Rise Time: 500 nS typical
Optical Fall Time: 16 nS typical

Mechanical Ratings

Mechanical Life: 10 million revolutions
Time Life: Guaranteed for 10 years of continuous operation (calculated from emitter degradation data)
Mounting Torque: 20 in-lbs maximum
Shaft Push Out Force: 100 lbs
Terminal Strength: 5 lbs terminal pull-out force minimum
Solderability: 95% free of pin holes and voids
Operating Torque: 1.5 in-oz maximum (no detents) for unsealed versions

Environmental Ratings

Operating Temperature Range: -40°C to 85°C
Storage Temperature Range: -55°C to 100°C
Relative Humidity: 90-95% at 40°C for 96 hours
Vibration Resistance: Harmonic motion with amplitude of 15g, within a varied 10 to 2000 Hz frequency for 12 hours per MIL-STD-202, Method 204
Shock Resistance: Test 1: 100g for 6 mS, half-sine wave with velocity change of 12.3 ft/s. Test 2: 100g for 6 mS, sawtooth wave with velocity change of 9.7 ft/s.
Shaft Seal: IP67 (61RS only)

Materials and Finishes

Bushing: Aluminum

Header: Phosphor bronze, 200 microinches tin over 50 microinches nickel (pin version only)

Cable: 26 AWG, stranded/tinned wire, PVC coated on .100 (2,54) centers (cable version only)

ORDERING INFORMATION

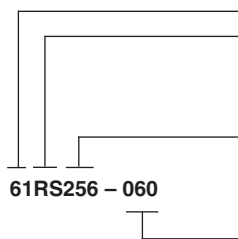

Series

Style: K = Standard, 4-pin, high resolution
 KS = Sealed, 4-pin, high resolution
 R = Standard, 5-pin, high resolution
 RS = Sealed, 5-pin, high resolution

Cycles: per channel per revolution = 25, 32, 50, 64, 100, 128, 256

Cable Termination: 060 = 6.0in. Cable is terminated with Molex Connector P/N 14-56-3056

Available from your local Grayhill Distributor. For prices and discounts, contact a local Sales Office, an authorized local Distributor or Grayhill.

Optical and Mechanical Encoders

ACCESSORIES

Non-Turn Washer

The Series 61 bushing is 3/8 inches in diameter and has a non-turn keyway to prevent rotation of the switch body when the panel is cut to fit.

Another way to keep the switch from turning is to use a non-turn washer. The washer is cadmium-plated brass.

Part number: **12C1087-1**

Part number: **SHH694-11**, 302-2B stainless steel, no plating

Shaft and Panel Seal

For shaft and panel seal version, the shaft is sealed by an o-ring inside the bushing. The panel is sealed by a flat gasket .045" thick at the base of the bushing. The panel seals will increase the behind panel dimension by .020" to .040", when the switch is mounted. The panel seal is silicon rubber.

DIMENSIONS In inches (and millimeters)

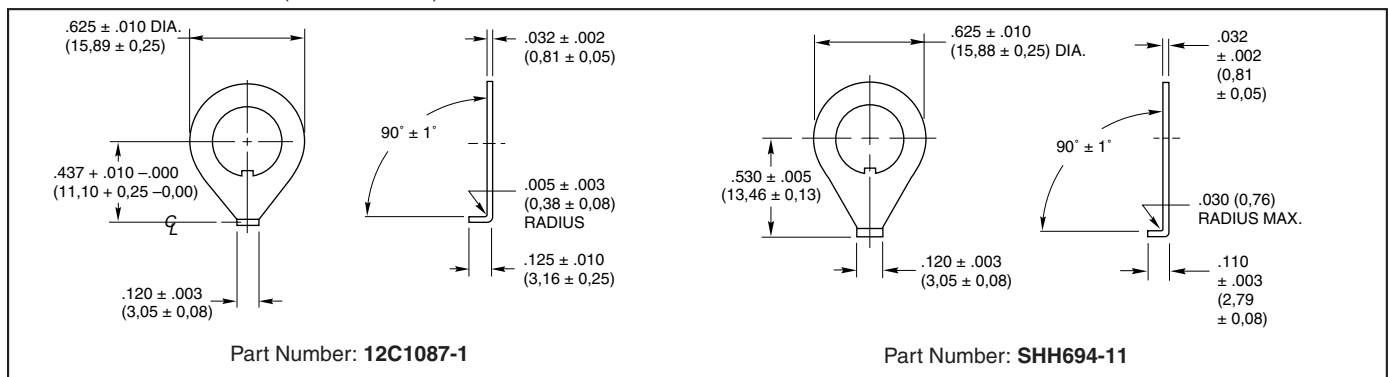



Optical Encoder Engineering Information

QUADRATURE

All Grayhill encoders use quadrature output code, which is the same as a 2-bit, repeating gray code. Quadrature is the most popular and cost effective output format because only two detectors are required. However, quadrature can only be used in applications where incremental data is required. Absolute positioning is not possible because the code repeats every four positions. In other words, changes in the encoder in magnitude and direction can be determined, but the actual position of the encoder cannot. In most applications this is not a problem.

In a quadrature rotary optical encoder two detectors are used to provide outputs, "A" and "B". The code rotor either blocks the infrared light or allows it to pass to the detectors. As the shaft turns the rotor, the outputs change state to indicate position. The resulting output is two square waves which are 90° out of phase.

OPEN COLLECTOR OUTPUT

The open collector output is typical of the Series 61B, 61C and 62, and is the simplest form of output available. The first step in interfacing with open collector outputs is to provide an external pull-up resistor from each output to the power source. These pull-up

resistors provide the output with the high-state voltage when the phototransistor is "off".

In a phototransistor, base current is supplied when light strikes the detector, which effectively grounds the output. Typically, the detector is operated in saturation. This means sufficient light is provided to completely sink, or ground, all the current provided by the pull up resistor plus that of the interfacing electronics. In the logic high state, the light is sufficiently blocked by the rotor and the detector functions like an open circuit. The pull up resistor then provides sourcing current to the interfacing electronics. This "on" or "off" digital arrangement allows the open collector to interface with popular integrated circuit technologies such as TTL, TTL LS, CMOS, and HCMOS.

SCHMITT TRIGGERS

To provide signal enhancement it is recommended that a Schmitt Trigger be connected to each output. This device is already included in the Series 61K, 61R, 63K and 63R encoders. The Schmitt Trigger "cleans up" the output into a pure digital signal. It does this by removing the small linear region between the "on" and "off" states of the detector. During this transition the light is only partially blocked and the output is somewhere between what the interfacing circuit might con-

sider to be "on" or "off". In other words, the output is not completely digital. The Schmitt Trigger contains a very important feature which makes it attractive for this application. The device has a higher threshold, or trigger level, when it is in the "on" state than it does in the "off" state. This hysteresis filters any electrical noise, which can cause the output to change state rapidly during the transition. And since the output from the Schmitt Trigger is a pure digital signal and is isolated from the phototransistor, the signal is basically immune to loading problems that can effect encoders without the Schmitt Trigger. Schmitt Triggers are available in most popular IC technologies.

SHAFT AND PANEL SEAL

A shaft and panel seal are available to provide water-tight mounting for the Series 61B, 61D, 61K, 61R and 62 encoders. Sealing is accomplished by an o-ring shaft seal and a panel seal washer. The panel seal washer in the 61B and 61D encoders does not affect the overall dimensions of the switches. In the 61K and 61R encoders, the .045" thick washer is placed over the threads and sits flat on the base of the bushing. The 61KS and 61RS are also epoxy-sealed on the bottom of the switch to provide a completely sealed switch.

