

P	LTR	DESCRIPTION	DATE	DWN	APVD
	A	INITIAL CREATED	23DEC2019	CL	RS
	A1	ECR-22-136185	11MAR2022	JZ	WKH

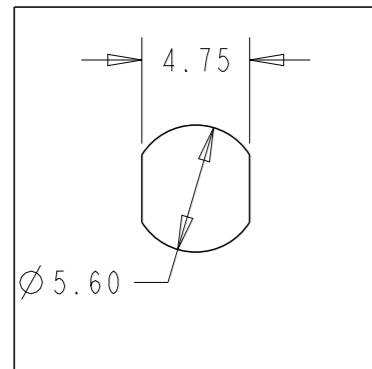

RECOMMENDED PANEL HOLE

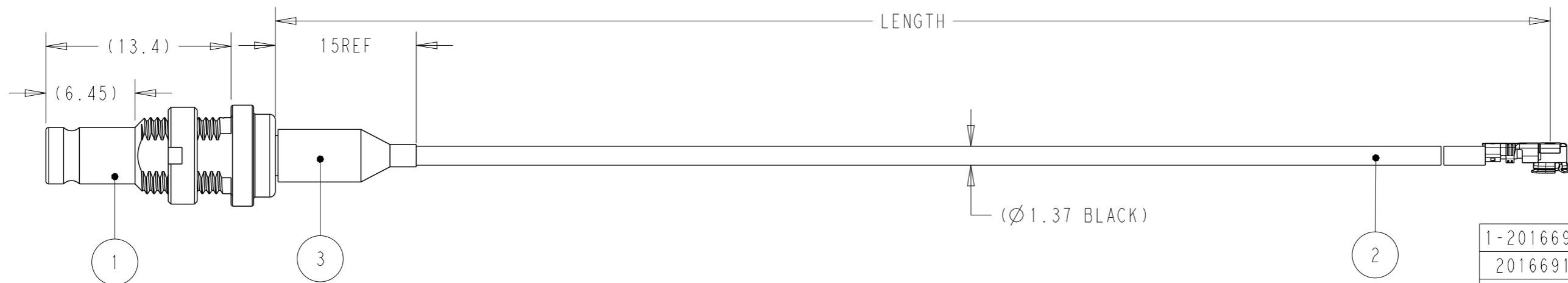
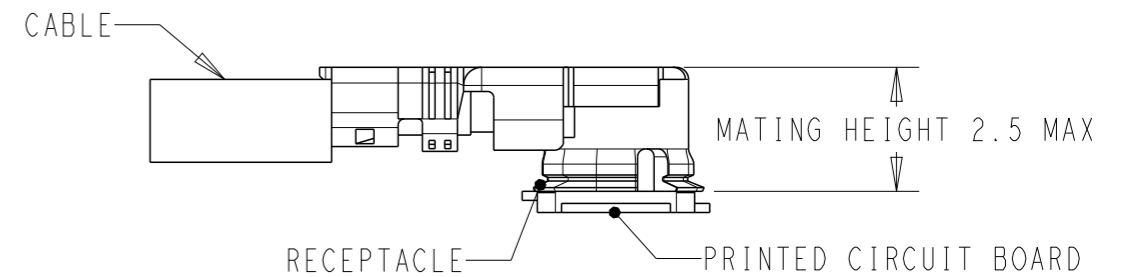

PART NUMBER	LENGTH
1-2016691-0	35±3
2016691-9	500±5
2016691-8	450±5
2016691-7	350±5
2016691-6	300±3
2016691-5	250±3
2016691-4	200±3
2016691-3	150±3
2016691-2	100±3
2016691-1	50+3

NOTES:

- MATERIAL AND PROCESSING MUST MEET REQUIREMENTS OF TEC-138-702
- 1.0-2.3 BULKHEAD NEED ASSEMBLY NUT
- PRODUCT RATING:  
 TEMPERATURE: -45°C TO +85°C  
 VOLTAGE: 30V (RMS)  
 CHARACTERISTIC IMPEDANCE: 50 OHMS Normal  
 FREQUENCY RANGE: DC TO 9GHz  
 BEND RADIUS: 7MM MIN
- CABLE ASSEMBLY TO BE 100% OPEN AND SHORT TESTED
- 1.0-2.3 INTERFACE FOLLOW IEC 61169-29  
 UMCC GEN1 CAN MATE WITH I-PEX MHF1 SERIES AND HIROSE U.FL SERIES

PC	Q'TY	UNIT	DESCRIPTION	ITEM
PC	1		HEAT SHRINK TUBE	3
PC	0.5		RF CA,UMCC GEN1 BOTH END, WITH 1.37CABLE	2
PC	1		1.0/2.3 BULKHEAD, FOR 1.37 CABLE	1

THIS DRAWING IS A CONTROLLED DOCUMENT.		DWN 04MAR2019 Cedar Liu														
DIMENSIONS: mm		CHK 04MAR2019 Roger Song														
TOLERANCES UNLESS OTHERWISE SPECIFIED:		APVD - Roger Song	NAME RF CA, 1.0-2.3 BULKHEAD TO UMCC GEN1 WITH 1.37CABLE													
<table border="1"> <tr> <td>0 PLC</td> <td>±-</td> </tr> <tr> <td>1 PLC</td> <td>±0.5</td> </tr> <tr> <td>2 PLC</td> <td>±0.13</td> </tr> <tr> <td>3 PLC</td> <td>±0.013</td> </tr> <tr> <td>4 PLC</td> <td>±0.0001</td> </tr> <tr> <td>ANGLES</td> <td>±-</td> </tr> </table>		0 PLC	±-	1 PLC	±0.5	2 PLC	±0.13	3 PLC	±0.013	4 PLC	±0.0001	ANGLES	±-	PRODUCT SPEC -	RESTRICTED TO	
0 PLC	±-															
1 PLC	±0.5															
2 PLC	±0.13															
3 PLC	±0.013															
4 PLC	±0.0001															
ANGLES	±-															
MATERIAL TBD		APPLICATION SPEC -	SIZE A3	CAGE CODE 00779												
FINISH -		WEIGHT -	DRAWING NO C-2016691													
finish_spec_2		RESTRICTED CUSTOMER	SCALE 1:1	SHEET 1 OF 1												
			REV A1													