

UG271: CP2615-EK2 User's Guide

The CP2615 device is designed to enable rapid development of USB-based audio applications.

The CP2615 simplifies the process of transferring audio data from USB to I2S without any code development, speeding time to market for USB audio accessories such as USB speakers, USB headphones and USB music boxes, as well as VoIP systems. The CP2615 includes a USB 2.0 full-speed function controller, USB transceiver, oscillator, I2S (audio) interface, I2C (control) interface and UART interface in a compact 5 x 5 mm QFN-32 package ideal for space-constrained portable audio applications.

The CP2615-EK2 kit includes the following:

- CP2615 Audio Bridge evaluation board
- 1 x Mini USB cable
- 1 x Micro USB OTG adapter
- 1 x micro USB cable
- 1 x USB Type-C to USB-A adapter
- Quick-Start Card

KEY FEATURES

- USB Audio class 1.0
- Supports USB HID Consumer Controls for Volume and Mute Synchronization
- Includes USB-UART bridge function
- Supports 48 kHz, 16-bit/ 24-bit stereo digital audio
- Integrated USB transceiver; no external resistors required
- Integrated clock; no external crystal required
- On-chip voltage regulator: 3.45 V output
- Self-powered or Bus-powered
- No firmware development

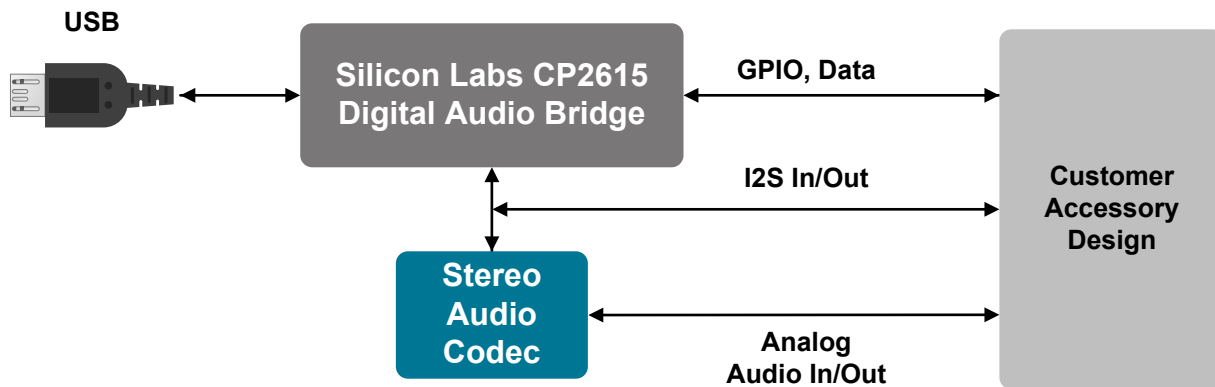

1. Getting Started

To start developing with the CP2615-EK2 Kit:

1. Connect the USB micro cable to [J11] of the CP2615 board. Depending on the type of receptacle on your phone, attach either the micro OTG adapter or the USB Type-C adapter to the other end of the USB cable. Then connect the other end of the adapter to your Android phone.

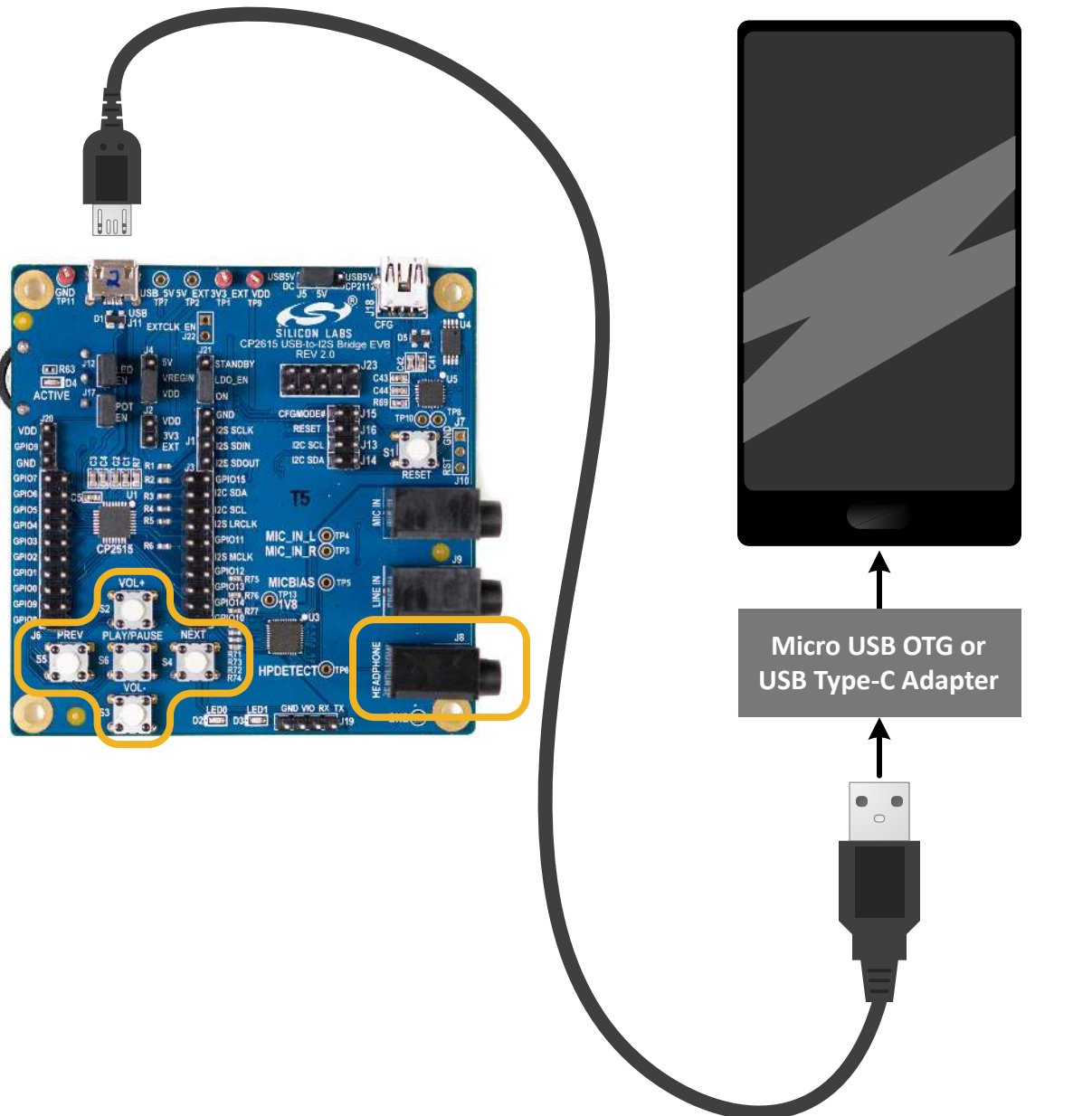

Micro OTG Adapter Cable

USB Type-C Adapter Cable

2. Connect headphones to [J8] of the CP2615 board and use your favorite Android audio application to play music.
3. Use the buttons to control volume, play and pause the music, and skip to the next track or back to the previous track.

2. Hardware Overview

The CP2615-EK2 board enables audio development. The figures below provide an overview of the board and the simplified board block diagram. Full schematics for the board can be found in the [Schematics](#) section.

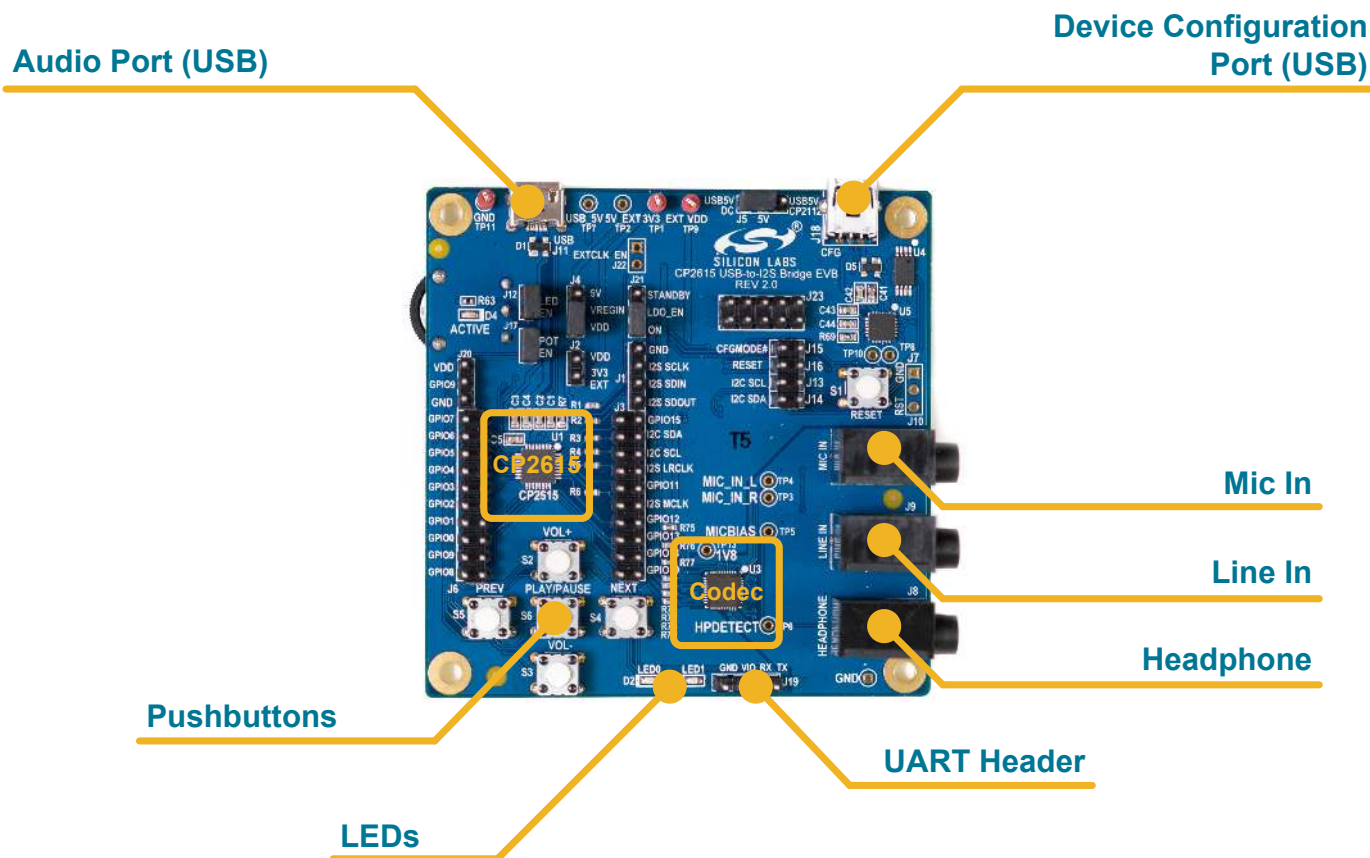
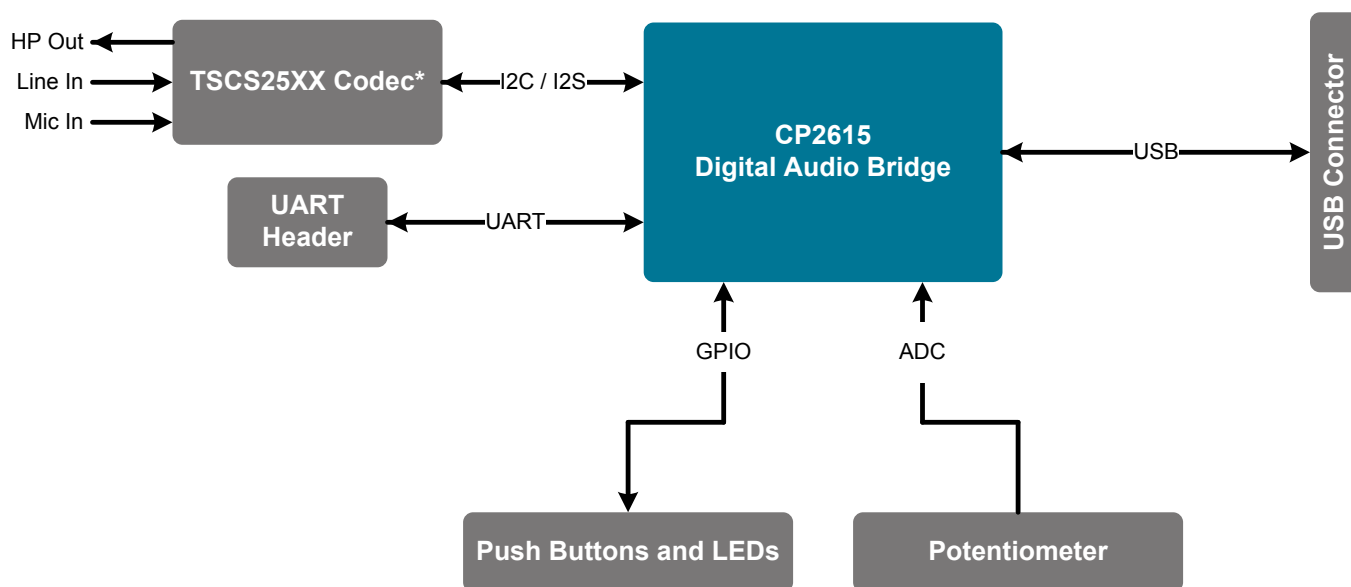

Figure 2.1. CP2615-EK2 Digital Audio Evaluation Kit



* Other codec solutions are supported.

Figure 2.2. CP2615-EK2 Digital Audio Evaluation Kit—Simplified Board Block Diagram

2.1 Power Selection Jumpers

The CP2615-EK2 supports USB bus-powered or self-powered configurations based on jumper settings. In USB bus-powered mode, the CP2615-EK2 is powered by VBUS from the Audio USB connector (J11). In self-powered mode, the CP2615-EK2 is powered from either the Configuration USB connector (J18) or from an external supply.

Table 2.1. USB Bus-Powered Configuration

Header	Position
J5	USB5V/DC (left)
J4	5V – VREGIN (top)
J2	Open (not installed)

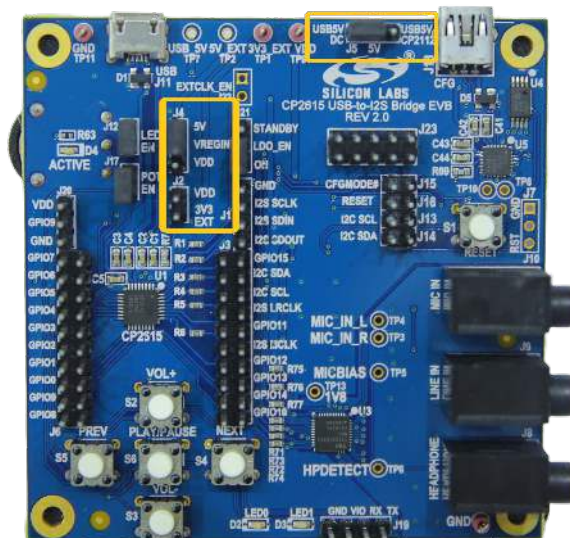

Figure 2.3. USB Bus-Powered Configuration

Table 2.2. 3.3 V Self-Powered Configuration

Header	Position
J5	Open (not installed)
J4	VREGIN – VDD (bottom)
J2	Installed
TP1	Apply external 3.3 V

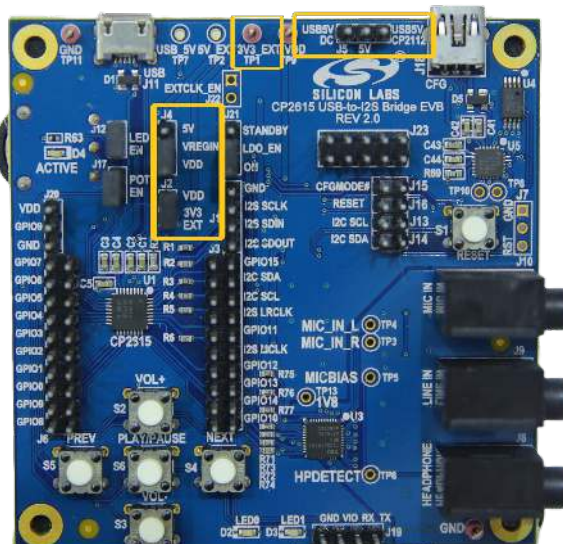
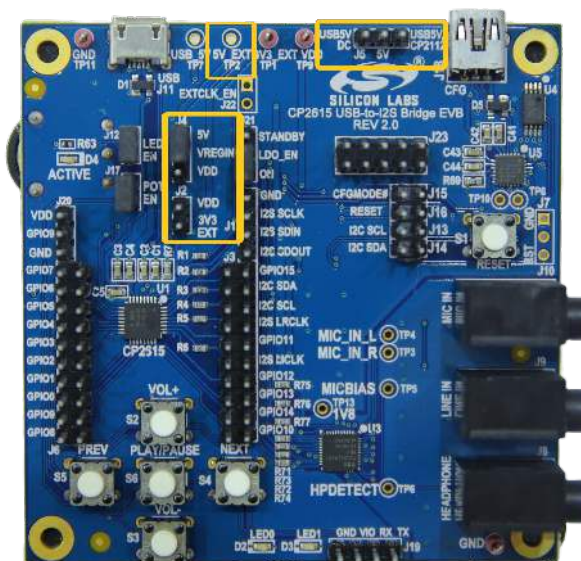

Figure 2.4. 3.3 V Self-Powered Configuration

Table 2.3. 5 V Self-Powered Configuration

Header	Position
J5	Open (not installed)
J4	5V - VREGIN (top)
J2	Open (not installed)
TP2	Apply external 5 V

Figure 2.5. 5 V Self-Powered Configuration



2.2 CP2615 Configuration Jumpers

The CP2615-EK2 includes a CP2112 and a set of jumpers that are used to configure the CP2615 device over the I2C bus.

Table 2.4. CP2615 Configuration Jumpers

Header	Description
J15	Connects CP2112 pin GPIO.0/TXT to the CP2615 CFGMODEb pin
J16	Connects CP2112 pin GPIO.1/RXT to the CP2615 RSTb pin
J13	Connects CP2112 SCL pin to the I2C_SCL net and CP2615 I2C SCL pin
J14	Connects CP2112 SDA pin to the I2C_SDA net and CP2615 I2C SDA pin

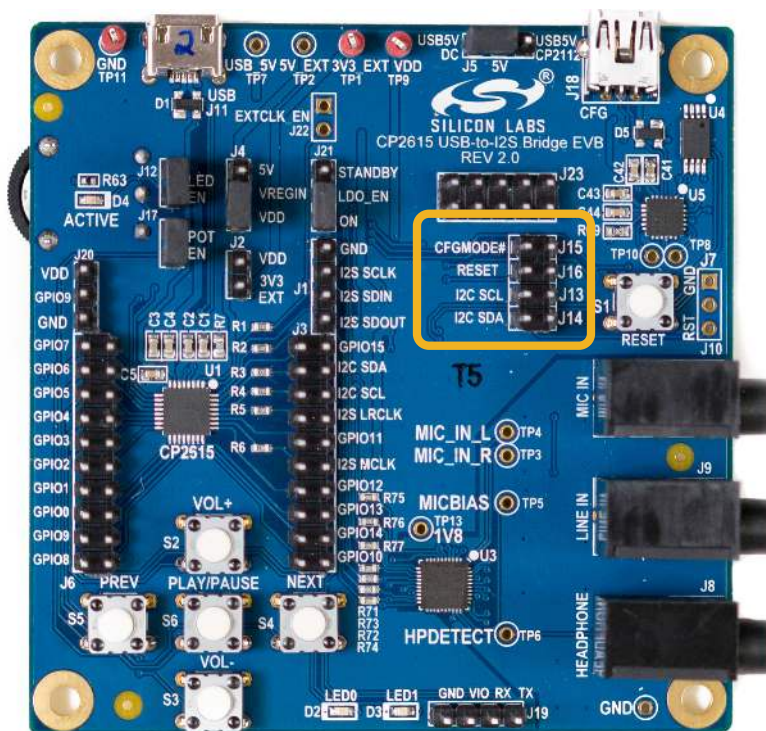

Figure 2.6. CP2615 Configuration Jumpers

2.3 Other Jumpers

The remaining jumpers on the boards disconnect peripherals like the potentiometer. All I/O also connect to the CP2615 through a zero-Ω resistor to isolate I/O from the board functions and enable development with application-specific hardware.

Table 2.5. Other Jumpers

Header	Description
J12	Connects the ACTIVE LED (D4) to CP2615 pin GPIO.2
J17	Connects the potentiometer (R63) to CP2615 pin GPIO.8/VBUS_SENSE/ADC
J19	UART Connector
J21	LDO_EN jumpered to ON: Power to codec and I2C pullup resistors is always applied. (NOTE: J21 must be in this position when programming a configuration.) LDO_EN jumpered to STANDBY: Power to codec and I2C pullup resistors is controlled by CP2615 GPIO.2 pin.

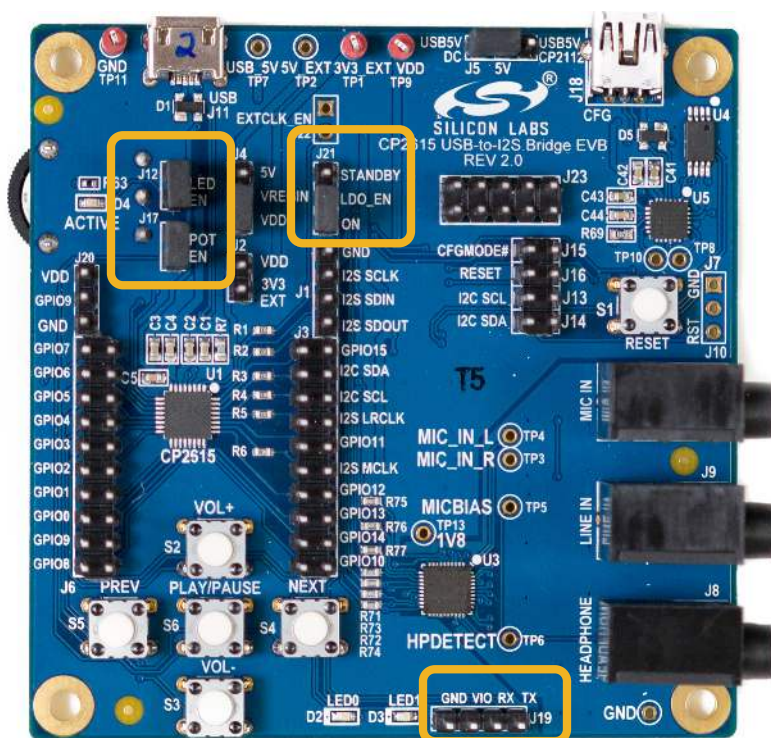

Figure 2.7. Other Jumpers

3. Device Customization

The CP2615 has several configurable options. The application note, *AN1044: CP2615 Customization Utility User Guide*, describes the configuration options in detail and how to use Xpress Configurator in Simplicity Studio (www.silabs.com/simplicity) to configure a CP2615 device. Once testing and development are complete, Silicon Labs offers CP2615 pre-programming services. Contact your local sales representative for more information.

Note: The following shorting blocks need to be installed to program a device using Xpress Configurator:

- J15 — CFGMODE#
- J16 — RESET
- J13 — I2C SCL
- J14 — I2C SDA
- J21 — LDO_EN to ON
- J5 — USB5V/CP2112 (Optional, to power from CP2112)

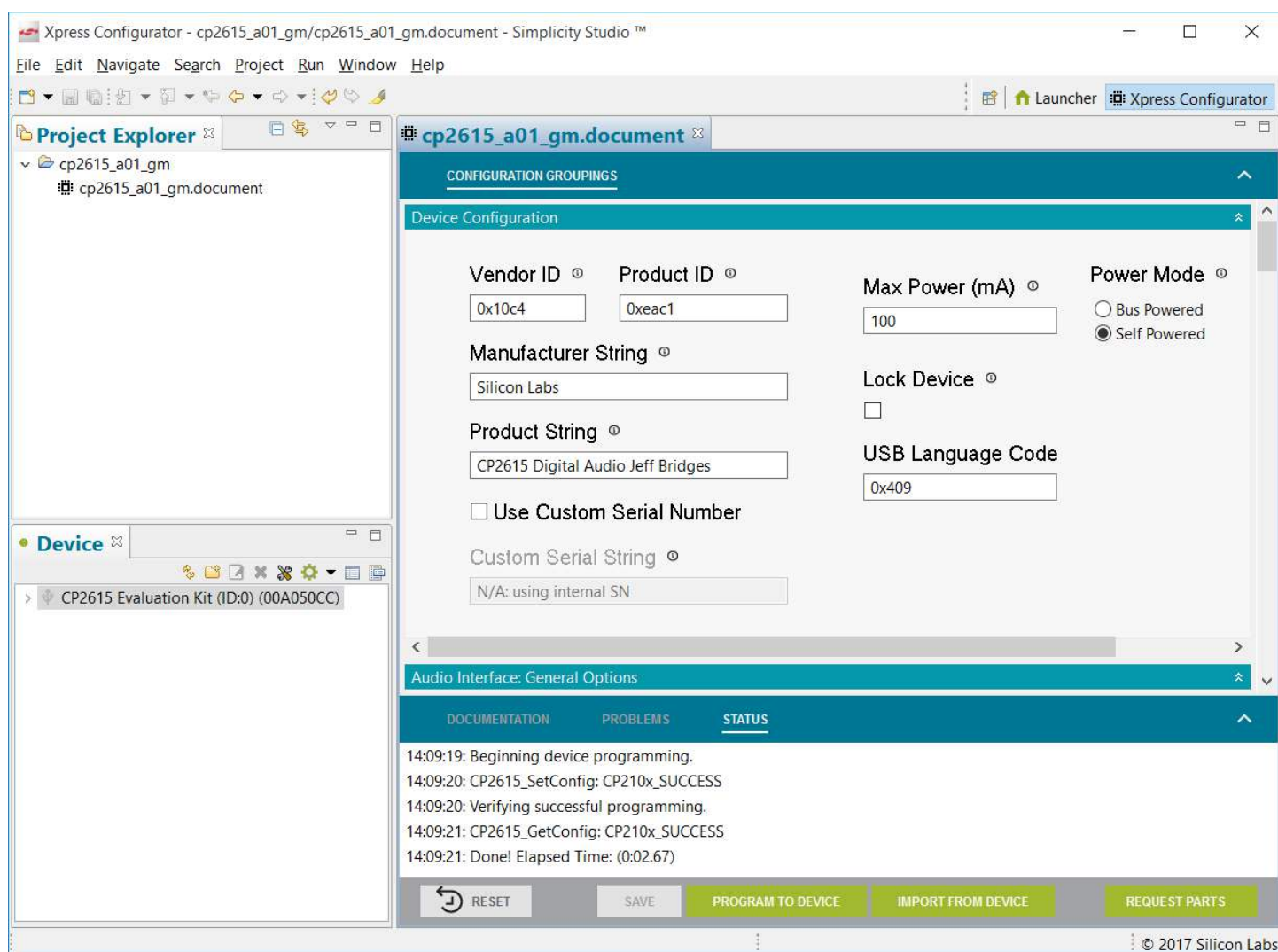

Figure 3.1. Xpress Configurator

3.1 CP2615 Customization on a Custom Board

To customize a CP2615 during development and prototyping, Xpress Configurator is the recommended GUI tool.

In a production setting, the Standalone Manufacturing Tool is an available command line tool for Windows, Mac and Linux. This tool, `cp2615smt.exe`, is available through the *USB Xpress Host SDK*. For more information about the Standalone Manufacturing Tool, see Application Note *AN721: USBXpress Device Customization Guide*.

To customize a CP2615, Xpress Configurator and the Standalone Manufacturing Tool require a CP2112 USB-to-I2C bridge, and the CP2112's PID must be 0xEA93. See the following connection diagram.

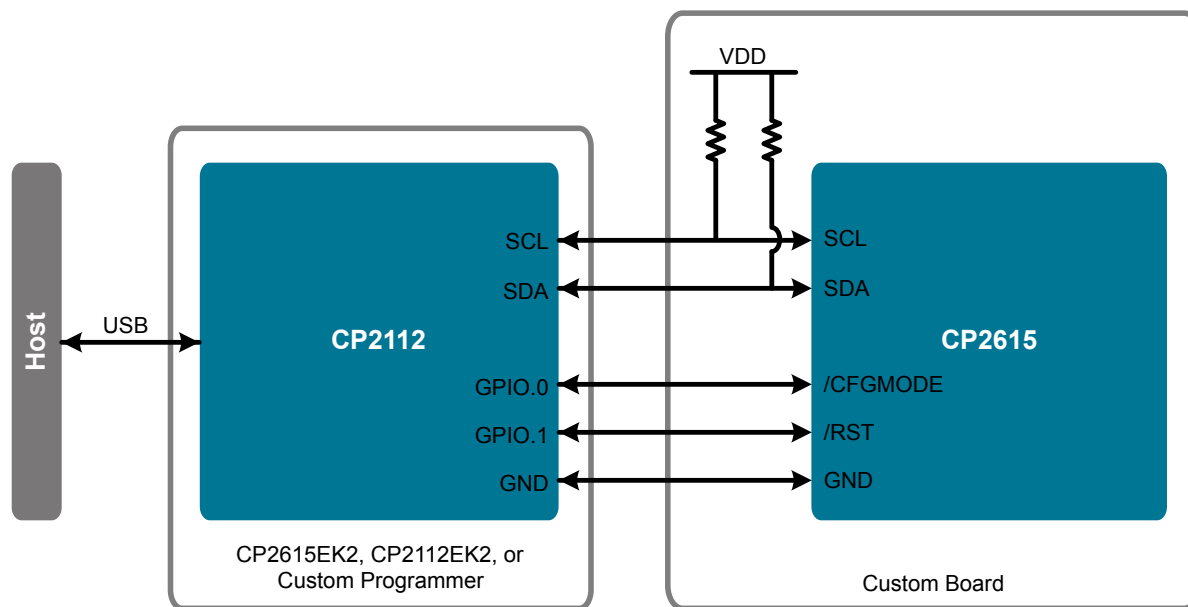

Figure 3.2. Connection Diagram

By default, the CP2112 PID is 0xEA90. To change the PID of a CP2112, use Xpress Configurator and refer to Application Note *AN721: USBXpress Device Customization Guide*.

Note: A CP2112 with PID 0xEA93 is included on the CP2615 Evaluation Board. Therefore, the CP2615 on the CP2615 Evaluation Board is ready for customization by Xpress Configurator and the Standalone Manufacturing Tool.

Note: When using the CP2112 on the CP2615 Evaluation Kit to program a CP2615 on a custom board, remove the shorting blocks on J13, J14, J15, and J16.

4. Schematics and Bill of Materials

The schematics and bill of materials (BOM) for the CP2615-EK2 board are available through Simplicity Studio (www.silabs.com/simplicity) when the kit documentation package has been installed.

5. Board Revision History

- 1.0 — Initial production revision.

1.0 Revision Boards

The left and right audio channels are reversed on this revision of the board. There is a codec setting that can swap the channels to the correct order, but the default board configuration will be incorrect. For more information on how to update the board configuration setting for an affected board, see the following Knowledge Base article:

https://community.silabs.com/s/article/left-and-right-codec-channels-reversed-on-the-cp2615-usb-to-i2s-bridge-evb-rev-1?language=en_US

This issue will be corrected in the next revision.

6. Revision History

6.1 Revision 0.5

December, 2022

- Removed Figure 2.3 Power Jumpers
- Renamed [Table 2.2 3.3 V Self-Powered Configuration on page 6](#) to 3.3V Self-Powered Configuration
- Added [Table 2.3 5 V Self-Powered Configuration on page 7](#) 5V Self-Powered Configuration
- Added Figures for [Table 2.1 USB Bus-Powered Configuration on page 6](#), [Table 2.2 3.3 V Self-Powered Configuration on page 6](#), and [Table 2.3 5 V Self-Powered Configuration on page 7](#)
- Header JP1 renamed to J21 in 2.3 Other Jumpers
- Added Header J5 position in [3. Device Customization](#)
- Updated the Knowledge Article link in [5. Board Revision History](#)

6.2 Revision 0.4

April, 2018

- Updated part number to replace CP2615-EK with CP2615-EK2.
- Updated figures for board revision 2.0.
- Header JP1 renamed to J21 in [2.3 Other Jumpers](#).
- Added J21 to [3. Device Customization](#).

6.3 Revision 0.3

July 17, 2017

- Added [3.1 CP2615 Customization on a Custom Board](#).

6.4 Revision 0.2

May 5, 2017

- Added [5. Board Revision History](#).

6.5 Revision 0.1

April 12, 2017

- Initial release.

Simplicity Studio

One-click access to MCU and wireless tools, documentation, software, source code libraries & more. Available for Windows, Mac and Linux!



IoT Portfolio
www.silabs.com/IoT



SW/HW
www.silabs.com/simplicity



Quality
www.silabs.com/quality



Support & Community
www.silabs.com/community

Disclaimer

Silicon Labs intends to provide customers with the latest, accurate, and in-depth documentation of all peripherals and modules available for system and software implementers using or intending to use the Silicon Labs products. Characterization data, available modules and peripherals, memory sizes and memory addresses refer to each specific device, and "Typical" parameters provided can and do vary in different applications. Application examples described herein are for illustrative purposes only. Silicon Labs reserves the right to make changes without further notice to the product information, specifications, and descriptions herein, and does not give warranties as to the accuracy or completeness of the included information. Without prior notification, Silicon Labs may update product firmware during the manufacturing process for security or reliability reasons. Such changes will not alter the specifications or the performance of the product. Silicon Labs shall have no liability for the consequences of use of the information supplied in this document. This document does not imply or expressly grant any license to design or fabricate any integrated circuits. The products are not designed or authorized to be used within any FDA Class III devices, applications for which FDA premarket approval is required or Life Support Systems without the specific written consent of Silicon Labs. A "Life Support System" is any product or system intended to support or sustain life and/or health, which, if it fails, can be reasonably expected to result in significant personal injury or death. Silicon Labs products are not designed or authorized for military applications. Silicon Labs products shall under no circumstances be used in weapons of mass destruction including (but not limited to) nuclear, biological or chemical weapons, or missiles capable of delivering such weapons. Silicon Labs disclaims all express and implied warranties and shall not be responsible or liable for any injuries or damages related to use of a Silicon Labs product in such unauthorized applications.

Note: This content may contain offensive terminology that is now obsolete. Silicon Labs is replacing these terms with inclusive language wherever possible. For more information, visit www.silabs.com/about-us/inclusive-lexicon-project

Trademark Information

Silicon Laboratories Inc.[®], Silicon Laboratories[®], Silicon Labs[®], SiLabs[®] and the Silicon Labs logo[®], Bluegiga[®], Bluegiga Logo[®], EFM[®], EFM32[®], EFR, Ember[®], Energy Micro, Energy Micro logo and combinations thereof, "the world's most energy friendly microcontrollers", Redpine Signals[®], WiSeConnect, n-Link, ThreadArch[®], EZLink[®], EZRadio[®], EZRadioPRO[®], Gecko[®], Gecko OS, Gecko OS Studio, Precision32[®], Simplicity Studio[®], Telegesis, the Telegesis Logo[®], USBXpress[®], Zentri, the Zentri logo and Zentri DMS, Z-Wave[®], and others are trademarks or registered trademarks of Silicon Labs. ARM, CORTEX, Cortex-M3 and THUMB are trademarks or registered trademarks of ARM Holdings. Keil is a registered trademark of ARM Limited. Wi-Fi is a registered trademark of the Wi-Fi Alliance. All other products or brand names mentioned herein are trademarks of their respective holders.



Silicon Laboratories Inc.
400 West Cesar Chavez
Austin, TX 78701
USA

www.silabs.com