

REVISIONS					
REV	ECO	DESCRIPTION	DATE	BY	APPR
B1	-	RELEASED DRAWING	Nov-17-2014	Ben	Tommy
B2	-	Update the Drawing	Oct-08-2016	Regan	Tommy
B3	-	VOLTAGE UPDATE AND ADD KEY ICON	Jun-30-2020	Ronald	Tommy

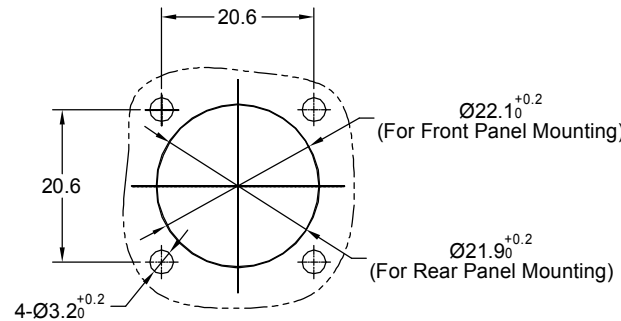

PANEL CUT OUT REFERENCE

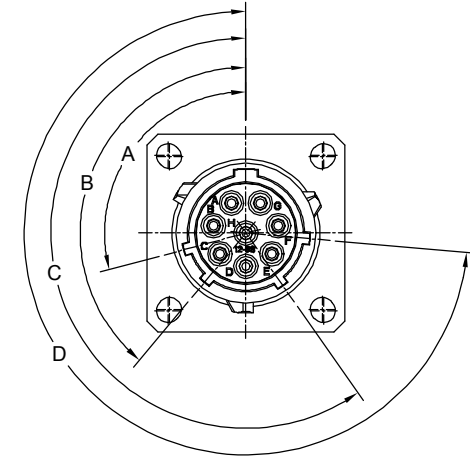
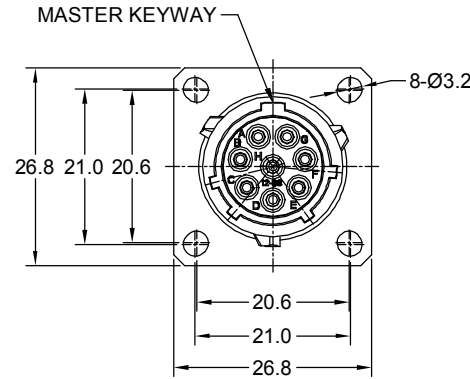
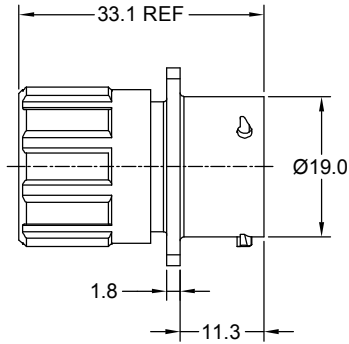
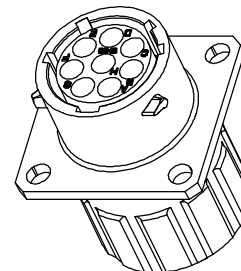

NOTES : (UNLESS OTHERWISE SPECIFIED)

- MATERIAL :
SHELL : ZINC ALLOY , NICKEL PLATED.
INSERT : THERMOPLASTIC , UL94 V-0.
END CAP : THERMOPLASTIC , UL94 V-0.
PLASTIC BUSHING : THERMOPLASTIC , UL94 V-0.
SEAL GASKET : NBR/SILICONE RUBBER.
O-RING : NBR/SILICONE RUBBER.
WIRE SEAL : SILICONE RUBBER.
- SPECIFICATIONS :
2.1 RATED CURRENT : 13A (MAX).
2.2 RATED VOLTAGE : 500V (AC/DC) .
2.3 OPERATING TEMPERATURE : SEE CHART.
2.4 DIELECTRIC WITHSTANDING VOLTAGE : LESS THAN 2 MILLIAMPS CURRENT LEAKAGE@2000 VOLTS AC.
2.5 INSULATION RESISTANCE : 5000 MEGOHMS MIN.
2.6 IP--CLASS : IP67 (MATED CONDITION).
2.7 MATING CYCLES DURABILITY : 500 CYCLES MIN.
2.8 RoHS COMPLIANT.
- SUITABLE CONTACTS : 16# CONTACTS.
- ALL DIMENSIONS ARE FOR REFERENCE USE ONLY.
- CONTACT SIZE AND REAR SEAL WIRE RANGE :

Contact Size	Insulation Overall Diameter(min-max)	Wire Range
16#	Ø2.0mm - Ø3.2mm	14 - 24AWG

KEY POS	PART NUMBER		A	B	C	D
	-40°C ~ 105°C	-40°C ~ 125°C				
N	RT00128SNHEC	RT00128SNHEC03	105°	140°	215°	265°
W	RT00128SWHEC	RT00128SWHEC03	60°	140°	215°	265°
X	RT00128SXHEC	RT00128SXHEC03	105°	155°	215°	265°
Y	RT00128SYHEC	RT00128SYHEC03	105°	140°	225°	265°
Z	RT00128SZHEC	RT00128SZHEC03	105°	140°	215°	295°

QUANTITY	PART NUMBER	DESCRIPTION	ITEM
	SEE PART NUMBER CHART		

MATERIALS LIST		SIGNATURES		DATE
UNLESS OTHERWISE SPECIFIED		DRAWN:	Ronald	Jun-30-2020
1) All dimensions are in metric(mm).		CHECKED:	Flan	Jul-01-2020
2) Tolerances are as follows:		ENGINEER:		
1 PL DEC ±0.30		APPROVAL:	Tommy	Jul-02-2020
2 PL DEC ±0.15		CUSTOMER:		
3 PL DEC ±0.08		THIS DRAWING IS SUPPLIED FOR INFORMATION ONLY. DESIGN FEATURES, SPECIFICATIONS AND PERFORMANCE DATA SHOWN HEREON ARE THE PROPERTY OF THE AMPHENOL CORPORATION. NO RIGHTS OF REPRODUCTION ARE IMPLIED. ALL DIMENSIONS ARE SUBJECT TO NORMAL MANUFACTURING VARIATIONS.		
PROCESS SPECIFICATIONS:		<p>Amphenol</p> <p>Sine Systems - www.amphenol-sine.com 44724 Morley Drive Clinton Township, MI 48036</p>		
NEXT ASSY:		<p>ECOMATE RM,RECEPTACLE, SIZE 12,8POS, SOCKET,END CAP.</p>		
		SIZE	TYPE	DWG NO:
		B	C-	RT00128S*HECx
		SCALE	NONE	REVISION
				B3
		SHEET 1 OF 1		

TITLE: ECOMATE RM,RECEPTACLE SIZE 12,8POS,SOCKET,END CAP
DWG NO.: RT00128S*HECx
REV: B3
SH: 1
OF: 1