

## 2.8 Ω (Typ) Quad H-Bridge Motor Driver

The 34920 is a multifunctional analog ASIC. The 34920 integrates two circuits, four H-bridge drivers, a reset circuit in a single IC, and two DC/DC switching voltage regulators. Input voltage is 21 V to 42 V DC.

Each motor of the two driver blocks can be configured as either a DC motor driver with pulse width modulation (PWM)-control or a single bipolar step motor driver. In step motor mode, both drivers are capable of being operated in the quarter step mode.

In DC motor mode, both bridges in a driver are in parallel, providing 2.4 A of drive current. In step motor mode, each bridge in a driver drives one phase. Each phase is driven with a bipolar current mode drive.

### Features

- Individual Thermal Limit Protection
- User-Selectable Motors: 2 DC Motors (2.4 A/Motor), 2 Step Motors (W1-2 Phase Control), 1 DC Motor and 1 Step Motor
- 2 Buck Regulators (Switching @ 200 kHz)
- $V_{V2}$  Output Voltage Is Programmable to 10 V to 15 V DC (Externally Set)
- Low-Voltage Detection Reset ( $V_{V1}$  and  $V_{VB+}$ )
- Pb-Free Packaging Designated by Suffix Code EI

**34920**

**H-BRIDGE MOTOR DRIVERS**

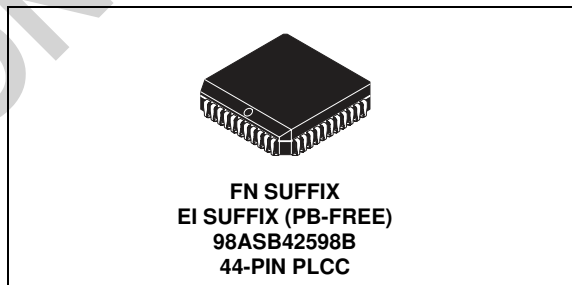

### ORDERING INFORMATION

Device	Temperature Range ( $T_A$ )	Package
MC34920FN/R2	-40°C to 125°C	44 PLCC
MC34920EI/R2		

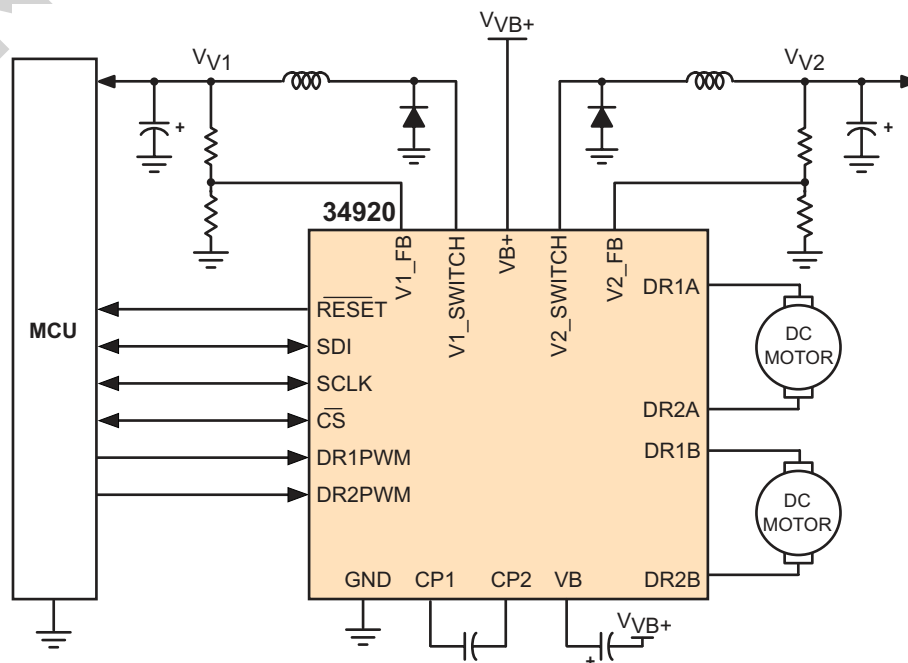

Figure 1. 34920 Simplified Application Diagram

\* This document contains certain information on a new product. Specifications and information herein are subject to change without notice.

### BLOCK DIAGRAM

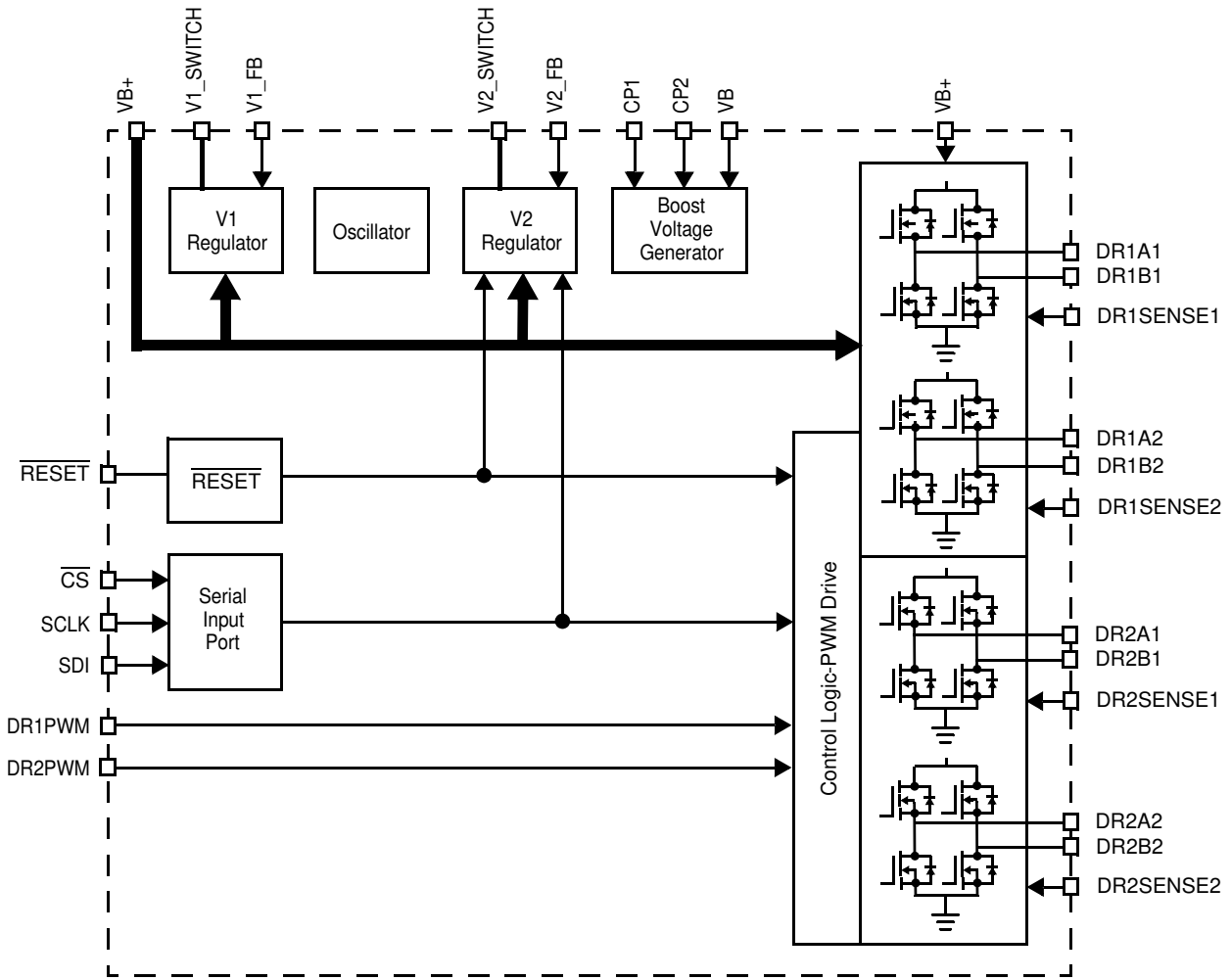

Figure 2. 34920 Simplified Internal Block Diagram

## PIN CONNECTIONS

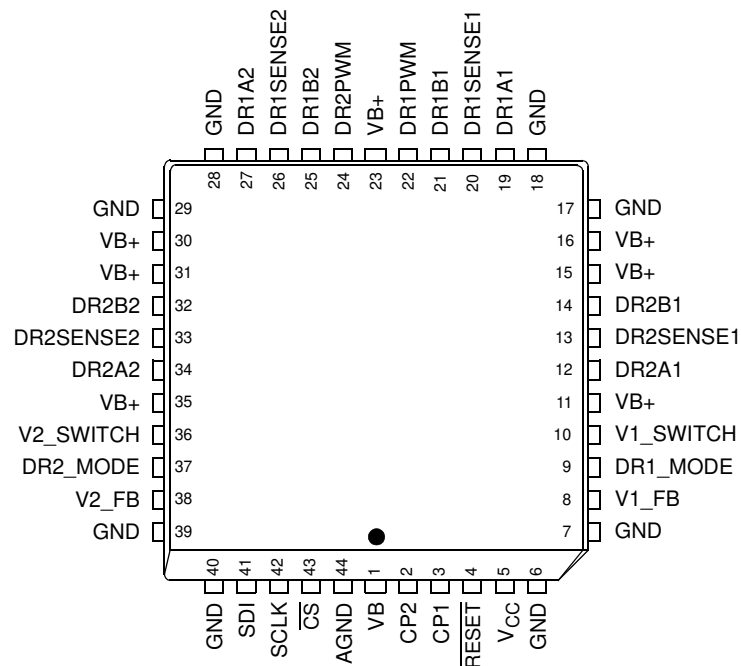

Figure 3. 34920 Pin Connections

Table 1. 34920 Pin Definitions

Pin Number	Pin Name	Formal Name	Definition
1	VB	Output pin to $V_{Vb}$	Pin to connect to $V_{Vb}$ capacitor.
2	CP2	Capacitor to CP1	Pin for boost generator switch capacitor.
3	CP1	Capacitor to CP2	Pin for boost generator switch capacitor.
4	RESET	Reset Output	Active low Reset output.
5	VCC	$V_{CC}$ Supply Voltage	$V_{CC}$ power input for internal use. The 34920 accepts either 3.3 V $\pm 10\%$ or 5.0 V $\pm 5\%$ for its logic voltage.
6, 7, 17, 18, 28, 29, 39, 40	GND	Substrate Ground	Ground connections for digital IC circuitry.
8	V1_FB	V1 Regulator Feedback Input	Voltage feedback for the V1 regulator.
9	DR1_MODE	Mode Select for Driver 1	Selects operational mode of Driver 1; Step = 1/DC = 0.
10	V1_SWITCH	Internal MOSFET Source for V1 Regulator	Switching output for V1 regulator.
11, 15, 16, 23, 30, 31, 35	VB+	VB+ (Bulk) Supply Voltage	High-voltage supply for motors and regulators.
12	DR2A1	Driver 2, Bridge 1, Output A	Motor driver output.
13	DR2SENSE1	Driver 2, Bridge 1, I Sense	Current sense for current mode.
14	DR2B1	Driver 2, Bridge 1, Output B	Motor driver output.
19	DR1A1	Driver 1, Bridge 1, Output A	Motor driver output.
20	DR1SENSE1	Driver 1, Bridge 1, I Sense	Current sense for current mode.

**Table 1. 34920 Pin Definitions (continued)**

Pin Number	Pin Name	Formal Name	Definition
21	DR1B1	Driver 1, Bridge 1, Output B	Motor driver output.
22	DR1PWM	Driver 1 PWM Input	PWM input for Driver 1. Used only when DR1_MODE pin = 0.
24	DR2PWM	Driver 2 PWM Input	PWM input for Driver 2. Used only when DR2_MODE pin = 0.
25	DR1B2	Driver 1, Bridge 2, Output B	Motor driver output.
26	DR1SENSE2	Driver 1, Bridge 2, I Sense	Current sense for current mode.
27	DR1A2	Driver 1, Bridge 2, Output A	Motor driver output.
32	DR2B2	Driver 2, Bridge 2, Output B	Motor driver output.
33	DR2SENSE2	Driver 2, Bridge 2, I Sense	Current sense for current mode.
34	DR2A2	Driver 2, Bridge 2, Output A	Motor driver output.
36	V2_SWITCH	Internal MOSFET Source for V2 Regulator	Switching output for V2 regulator.
37	DR2_MODE	Mode Select for Driver 2	Selects operational mode of Driver 2. Step = 1/DC = 0.
38	V2_FB	V2 Regulator Feedback Input	Switch output for V2 regulator.
41	SDI	Serial Port Data Input	Serial input register serial data input.
42	SCLK	Serial Data Port Clock	Serial input register clock.
43	CS	Serial Data Port Chip Select	Serial input register chip select input. Active low.
44	AGND	Analog Ground	Ground connection for analog circuitry.

## ELECTRICAL CHARACTERISTICS

### MAXIMUM RATINGS

**Table 2. Maximum Ratings**

All voltages are with respect to ground unless otherwise noted. Exceeding these ratings may cause a malfunction or permanent damage to the device.

Ratings	Symbol	Value	Unit
<b>ELECTRICAL RATINGS</b>			
VB+ Supply Voltage	$V_{VB+}$	45	V
VCC Voltage	$V_{CC(MAX)}$	7.0	V
Bridge Output Current	$I_{OUT}$	1.5	A
Maximum Voltage on $\overline{RESET}$ <sup>(1)</sup>	$V_{MAXRST}$	$V_{CC} - 0.5$	V
ESD Voltage <sup>(2)</sup>			V
Human Body Model	$V_{ESD1}$	±1000	
Machine Model	$V_{ESD2}$	±100	
<b>THERMAL RATINGS</b>			
Storage Temperature	$T_{STG}$	-40 to 175	°C
Operating Ambient Temperature	$T_A$	0 to 70	°C
Operating Junction Temperature	$T_J$	135	°C
Power Dissipation ( $T_A = 25^\circ\text{C}$ ) <sup>(3)</sup>	$P_D$	2.0	W
Pin Soldering Temperature <sup>(4)</sup>	$T_{SOLDER}$	220	°C
Thermal Resistance, Junction to Ambient <sup>(5)</sup>	$R_{\theta JA}$	37	°C/W

**Notes**

- $\overline{RESET}$  is an open drain (open collector) output with an internal pull-up resistor.
- ESD testing is performed in accordance with the Human Body Model (HBM) ( $C_{ZAP} = 100\text{ pF}$ ,  $R_{ZAP} = 1500\ \Omega$ ), the Machine Model (MM) ( $C_{ZAP} = 200\text{ pF}$ ,  $R_{ZAP} = 0\ \Omega$ ), and the Charge Device Model (CDM), Robotic ( $C_{ZAP} = 4.0\text{ pF}$ ).
- Maximum power dissipation at indicated ambient temperature in free air with no heatsink used.
- Pin soldering temperature limit is for 10 seconds maximum duration. Not designed for immersion soldering. Exceeding these limits may cause malfunction or permanent damage to the device.
- $R_{\theta JA}$  is dependent on customer application and PCB layout.

### STATIC ELECTRICAL CHARACTERISTICS

**Table 3. Static Electrical Characteristics**

Characteristics noted under conditions  $21\text{ V} \leq V_{VB+} \leq 42\text{ V}$ ,  $T_A = 10^\circ\text{C}$  to  $55^\circ\text{C}$ ,  $T_J \text{ max} = 135^\circ\text{C}$ ,  $V_{CC} = 5.25\text{ V}$  max unless otherwise noted. Typical values noted reflect the approximate parameter mean at  $T_A = 25^\circ\text{C}$  under typical conditions unless otherwise noted.

Characteristic	Symbol	Min	Typ	Max	Unit
<b>POWER INPUT</b>					
$V_{VB+}$ Supply Voltage	$V_{VB+}$	21	–	42	V
$V_{VB+}$ Standby Current $V_{VB+} = 42\text{ V}$ , $I_{CC}$ Load = 5.0 mA, No Serial Clock, No Motor Driver, No Load on $V_{V2}$	$I_{VB+}$	1.0	14	55	mA
<b>CMOS LOGIC LEVEL <sup>(6)</sup></b>					
Input Current, High-Voltage State	$I_{IH}$	–	0.1	170	$\mu\text{A}$
Input Current, Low-Voltage State	$I_{IL}$	-170	-0.1	–	$\mu\text{A}$
Input Low Input Voltage State $V_{CC} + 3.3\text{ V} \pm 10\%$ $V_{CC} + 5.0\text{ V} \pm 5\%$	$V_{IL}$	–	–	0.8 1.5	V
Input High-Voltage State $V_{CC} + 3.3\text{ V} \pm 10\%$ $V_{CC} + 5.0\text{ V} \pm 5\%$	$V_{IH}$	2.1 3.3	– –	– –	V
<b>V1 AND V2 VOLTAGE REGULATORS</b>					
Regulator Output Voltage	$V_{OUT}$	-4.0%	Nom	+4.0%	V
Regulator Thermal Shutdown Junction Temperature	$T_{J(\text{SHUTDOWN})}$	155	–	175	$^\circ\text{C}$
Regulator Thermal Junction Temperature	$T_{J(\text{ENABLE})}$	135	–	155	$^\circ\text{C}$
Overcurrent Detect Level (Peak) for $I_{V1\_SWITCH}$	$I_{OC\_V1}$	1.5	2.0	2.5	A
Overcurrent Detect Level (Peak) for $I_{V2\_SWITCH}$	$I_{OC\_V2}$	2.5	3.25	4.0	A
Short Circuit Detect Level (Peak) for $I_{V1\_SWITCH}$ In Soft Start and Foldback Modes	$I_{SC\_V1}$	0.75	1.25	1.75	A
Short Circuit Detect Level (Peak) for $I_{V2\_SWITCH}$ In Soft Start and Foldback Modes	$I_{SC\_V2}$	1.75	2.25	2.75	A
V1 Switching MOSFET on Resistance Full On, Typical Value @ $T_J = 25^\circ\text{C}$	$R_{DS(\text{ON})V1}$	–	2.0	–	$\Omega$
V2 Switching MOSFET on Resistance Full On, Typical Value @ $T_J = 25^\circ\text{C}$	$R_{DS(\text{ON})V2}$	–	0.75	–	$\Omega$
Regulator Feedback Input Internal Reference Value of 2.50 V $\pm 2\%$	$V_{V1\_FB}$ , $V_{V2\_FB}$	–	2.5	–	V
Turn-Off Regulator $V_{V1}$ Output/ $V_{V2}$ Output = 0 V	$V_{OFFV1\_FB}$ , $V_{OFFV2\_FB}$	3.0	–	–	V

Notes

6. Applicable to all logic level input signals. Inputs are to be designed to accept 3.3 V logic levels and be +5.0 V tolerant.

**Table 3. Static Electrical Characteristics (continued)**

Characteristics noted under conditions  $21\text{ V} \leq V_{VB+} \leq 42\text{ V}$ ,  $T_A = 10^\circ\text{C}$  to  $55^\circ\text{C}$ ,  $T_J \text{ max} = 135^\circ\text{C}$ ,  $V_{CC} = 5.25\text{ V}$  max unless otherwise noted. Typical values noted reflect the approximate parameter mean at  $T_A = 25^\circ\text{C}$  under typical conditions unless otherwise noted.

Characteristic	Symbol	Min	Typ	Max	Unit
Voltage Overshoot External $V_{CC}$ Load Current from 0.01 to 0.500 A, $t_{RISE} > 100\text{ ns}$	$V_{OVRSH}$	–	5.0%	–	–
Load Ripple 0.5 A maximum	$V_{OUTRIPPLE}$	–	100	–	mV

**VBOOST GENERATOR**

Charge Pump Output Voltage $I_{LOAD} = 1.0\text{ mA}$	$V_{VB-} - V_{VB+}$	10	–	14	V
----------------------------------------------------------	---------------------	----	---	----	---

**BIPOLAR CURRENT REGULATED STEP MOTOR DRIVE SYSTEM**

Peak Step Motor Current, Phase A or B Motor Not Stalled	$I_{STEPMOTOR\ PEAK}$	–	–	0.6	A
Maximum Allowable Voltage Drop Across Any H-Bridge Switch $I_{LOAD} = 0.6\text{ A}$ (from Output to GND) or $I_{LOAD} = 0.6\text{ A}$ (from $V_{VB+}$ to Output)	$V_{DROP}$	–	–	1.6	V
Comparator High Threshold Voltage $CURR\_I0\_PHASEX=0$ , $CURR\_I1\_PHASEX=0$	$V_{TH}$	450	550	650	mV
Comparator Medium Threshold Voltage $CURR\_I0\_PHASEX=1$ , $CURR\_I1\_PHASEX=0$	$V_{TM}$	300	–	440	mV
Comparator Low Threshold Voltage $CURR\_I0\_PHASEX=0$ , $CURR\_I1\_PHASEX=1$	$V_{TL}$	105	–	255	mV
$V_{OFF}$ Output Leakage Current for Step Motor Driver Outputs $V_{OFF} = 5.0\text{ V}$	$I_{OFF}$	-1.0	0.1	1.0	mA
Step Motor Driver Thermal Shutdown Junction Temperature	$T_{J(SHUTDOWN)}$	155	–	175	$^\circ\text{C}$
Step Motor Driver Thermal Enable Junction Temperature	$T_{J(ENABLE)}$	135	–	155	$^\circ\text{C}$
Single MOSFET Typical Value @ $T_J = 25^\circ\text{C}$	$R_{DS(ON)}$	–	1.43	–	$\Omega$

**DC MOTOR DRIVE SYSTEM**

Maximum Allowable Voltage Drop Across Any H-Bridge Switch $I_{LOAD} = 0.75\text{ A}$ (from Output to GND) or $I_{LOAD} = 0.75\text{ A}$ (from $V_{VB+}$ to Output) (Using 2 H-Bridges in Parallel)	$V_{DROP}$	–	–	1.3	V
Peak DC Motor Driver Current Motor Not Stalled (Using 2 H-Bridges in Parallel)	$I_{DCMOTOR\ PEAK\ CURRENT}$	–	–	1.2	A
DC Motor Overcurrent Threshold <sup>(7)</sup> Motor Stalled (Paralleled H-Bridges Used for DC Motor Drive)	$I_{DCMOTOR\ OCT}$	1.6	2.0	2.5	A
DC Motor Driver Sustaining Current Value Current Allowed to Sustain for a Minimum of 100 ms (OCT delay), Current Ripple 100 mA (Peak-to-Peak or Less)	$I_{DC\_SUSTAIN}$	1.6	2.0	2.4	A

**Notes**

- Because the current clamp is applied to the top H-bridge transistors only, overcurrent protection applies to motor currents. But note that no short circuit protection exists against shorts from the DC motor outputs (DR1A1, DR1A2, DR1B1, or DR1B2 to substrate ground or to  $V_{B+}$ ).

**Table 3. Static Electrical Characteristics (continued)**

Characteristics noted under conditions  $21\text{ V} \leq V_{VB+} \leq 42\text{ V}$ ,  $T_A = 10^\circ\text{C}$  to  $55^\circ\text{C}$ ,  $T_J \text{ max} = 135^\circ\text{C}$ ,  $V_{CC} = 5.25\text{ V}$  max unless otherwise noted. Typical values noted reflect the approximate parameter mean at  $T_A = 25^\circ\text{C}$  under typical conditions unless otherwise noted.

Characteristic	Symbol	Min	Typ	Max	Unit
Differential DC Motor Driver Output Voltage $V_{VB+}$ Rising Monotonically from 0 V to 42 V ( $1.0\ \mu\text{s} < t_R < 10\text{ ms}$ ) OR $V_{VB+}$ Falling Monotonically from 42 V to 0 V ( $1.0\ \mu\text{s} < t_F < 10\text{ ms}$ )	$V_{DCMD}$	–	–	4.0	V
DC Motor Driver Thermal Shutdown Output Voltage $I_{OH} = 0.1\text{ V}$	$V_{OH\_DCM}$	$V_{VB+} - 0.5\text{ V}$	–	–	V
DC Motor Driver Thermal Shutdown Junction Temperature	$T_{J(\text{SHUTDOWN})}$	155	–	175	$^\circ\text{C}$
DC Motor Driver Thermal Enable Junction Temperature	$T_{J(\text{ENABLE})}$	135	–	155	$^\circ\text{C}$
Equivalent Resistance Using 2 H-Bridges in Parallel, Nom Value @ $T_J = 25^\circ\text{C}$	$R_{DS(\text{ON})}$	–	0.73	–	$\Omega$

**RESET**

$\overline{\text{RESET}}$ High-State Output Voltage $I_{OH} = -0.1\text{ mA}$	$V_{OH}$	$V_{CC} - 0.5\text{ V}$	–	–	V
$\overline{\text{RESET}}$ Low-State Output Voltage $V_{V1\_FB} < V_{V1T+}$	$V_{OL}$	–	–	0.2	V
Input Low Voltage State $V_{CC} + 3.3\text{ V} \pm 10\%$ $V_{CC} + 5.0\text{ V} \pm 5\%$	$V_{IL}$	– –	– –	0.8 1.5	V
Input High-Voltage State $V_{CC} + 3.3\text{ V} \pm 10\%$ $V_{CC} + 5.0\text{ V} \pm 5\%$	$V_{IH}$	2.1 3.3	– –	– –	V
$\overline{\text{RESET}}$ $V_{V1\_FB}$ Low Threshold Voltage at $V1\_FB$	$V_{V1T-}$	1.9	2.08	2.2	V
$\overline{\text{RESET}}$ $V_{V1\_FB}$ High Threshold Voltage at $V1\_FB$	$V_{V1T+}$	2.05	2.23	2.35	V
$\overline{\text{RESET}}$ $V_{VB+}$ Low Threshold $VB+$	$V_{VB+T-}$	13.5	15.4	16.5	V
$\overline{\text{RESET}}$ $V_{VB+}$ High Threshold $VB+$	$V_{VB+T+}$	13.5	16.6	20	V



### DYNAMIC ELECTRICAL CHARACTERISTICS

**Table 4. Dynamic Electrical Characteristics**

Characteristics noted under conditions  $21\text{ V} \leq V_{VB+} \leq 42\text{ V}$ ,  $T_A = 10^\circ\text{C}$  to  $55^\circ\text{C}$ ,  $T_J \text{ max} = 135^\circ\text{C}$ ,  $V_{CC} = 5.25\text{ V}$  max unless otherwise noted. Typical values noted reflect the approximate parameter mean at  $T_A = 25^\circ\text{C}$  under typical conditions unless otherwise noted.

Characteristic	Symbol	Min	Typ	Max	Unit
<b>SERIAL INPUT PORT TIMING</b>					
Serial Clock Frequency	$f_{\text{CLK}}$	–	4.0	12	MHz
SCLK High Width	$t_{\text{CLH}}$	41.667	125	–	ns
SCLK Low Width	$t_{\text{CLL}}$	41.667	125	–	ns
Delay $\overline{\text{CS}}$ Falling to First SCLK Rising	$t_{\overline{\text{CS}}\text{-SCLK}}$	83.333	250	–	ns
Delay Last SCLK Rising Edge to $\overline{\text{CS}}$ Rising	$t_{\text{SCLK-}\overline{\text{CS}}}$	83.333	250	–	ns
Data Valid to SCLK Set-Up Time	$t_{\text{DSU}}$	41.667	125	–	ns
Data Hold Time	$t_{\text{DHD}}$	41.667	125	–	ns
SDI Rise Time	$t_{\text{RD}}$	5.0	–	10	ns
SDI Fall Time	$t_{\text{FD}}$	5.0	–	10	ns
SCLK Rise/Fall Time	$t_{\text{RFC}}$	5.0	–	10	ns
$\overline{\text{CS}}$ Off-Time ( $t_{\text{DHD}} + t_{\text{DSU}}$ )	$t_{\overline{\text{NCS}}\text{-OFF}}$	83.333	250	–	ns
<b>V1 AND V2 VOLTAGE REGULATORS</b>					
Clock Frequency Overtemperature	$f_{\text{OP}}$	175	200	225	kHz
V1 Duty Cycle	V1_DC	35	37.5	40	%
V2 Duty Cycle	V2_DC	80	82.5	85	%
<b>BIPOLAR CURRENT REGULATED STEP MOTOR DRIVE SYSTEM</b>					
Shoot-Through Delay	$t_{\text{DEAD}}$	15	200	350	ns
Off-Time	$t_{\text{OFF}}$	20	29	38	$\mu\text{s}$
Current Blanking Time	$t_{\text{BLANK}}$	300	–	750	ns
<b>DC MOTOR DRIVE SYSTEM</b>					
PWM Frequency $T_A = 25^\circ\text{C}$	$f_{\text{PWM}}$	–	20	21	kHz
Shoot-Through Delay	$t_{\text{DEAD}}$	15	180	350	ns
Overcurrent Off-Time	$t_{\text{OC\_OFF}}$	10	40	70	$\mu\text{s}$

**Table 4. Dynamic Electrical Characteristics**

Characteristics noted under conditions  $21\text{ V} \leq V_{V_{B+}} \leq 42\text{ V}$ ,  $T_A = 10^\circ\text{C}$  to  $55^\circ\text{C}$ ,  $T_J \text{ max} = 135^\circ\text{C}$ ,  $V_{CC} = 5.25\text{ V}$  max unless otherwise noted. Typical values noted reflect the approximate parameter mean at  $T_A = 25^\circ\text{C}$  under typical conditions unless otherwise noted.

Characteristic	Symbol	Min	Typ	Max	Unit
<b>RESET</b>					
RESET Delay $V_{V1\_FB} \geq V_{V1T+}$	$t_{\text{DELAY}}$	15	33	50	ms
$V_{CC}$ Out-of-Tolerance Persistence Time RESET De-Asserted, $V_{V1\_FB} < V_{V1T-}$	$t_{\text{PERSIST}}$	10	20	30	$\mu\text{s}$
RESET Rise Time 10% to 90% <sup>(8)</sup>	$t_R$	–	630	750	ns
RESET Fall Time 90% to 10% <sup>(8)</sup>	$t_F$	–	11	50	ns

Notes

- 8. Test circuit is 50 pF capacitor from RESET to GND.

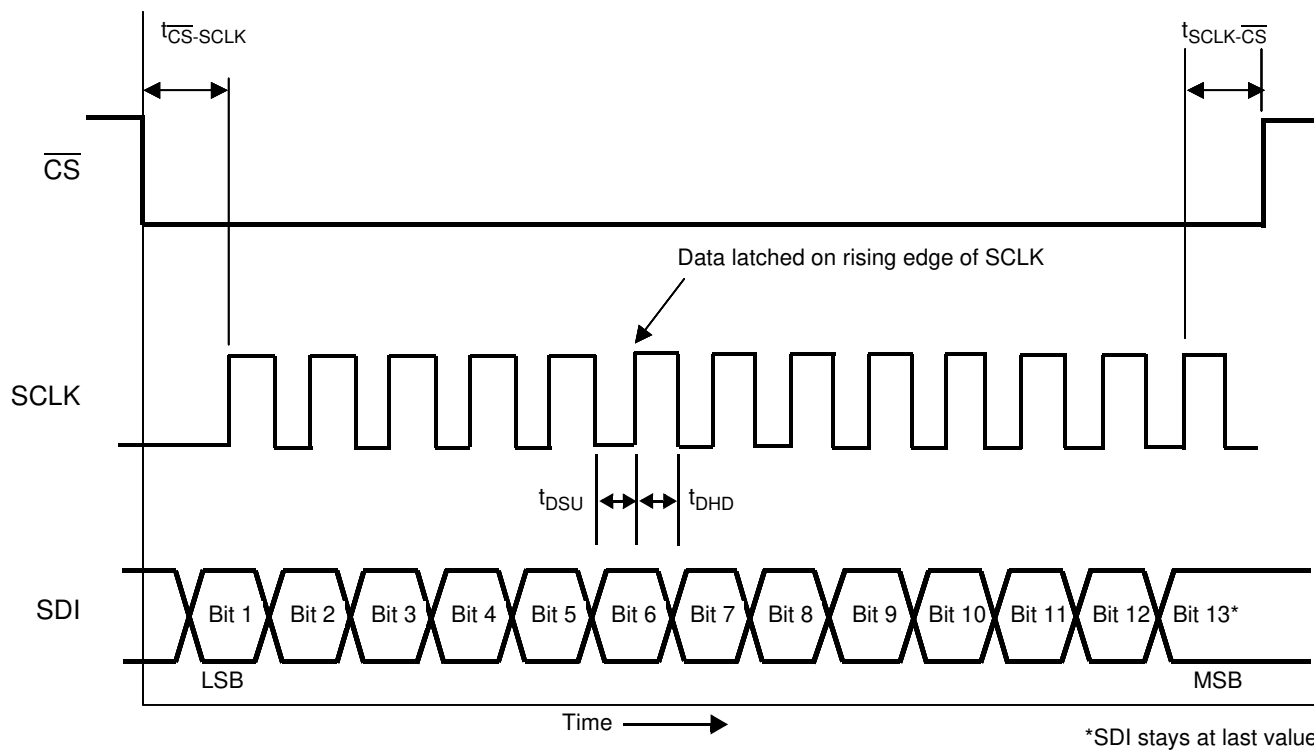
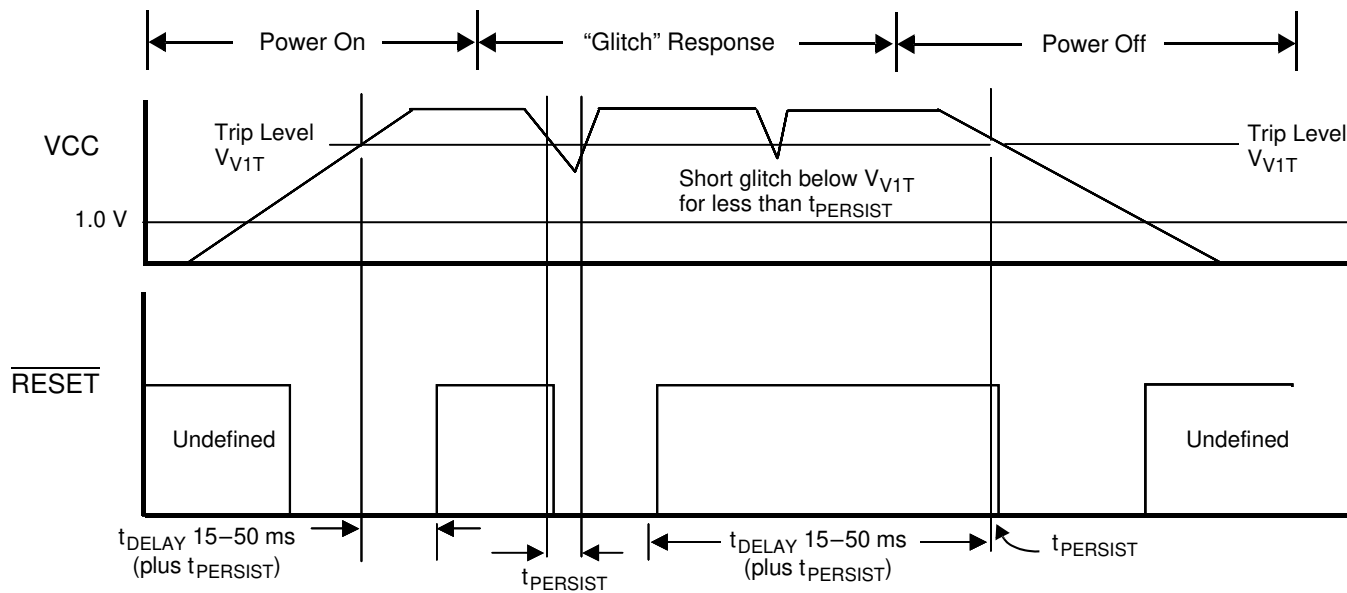
**TIMING DIAGRAMS**

**Figure 4. Serial Connectivity Diagram**

**Figure 5.  $\overline{\text{RESET}}$  Generation Timing Diagram (Assumes  $V_{VB+} > V_{VB+T+}$  During Entire Period)**

## FUNCTIONAL DESCRIPTION

### INTRODUCTION

The 34920 is a multifunctional analog IC that can be used in printer and scanner applications. It integrates two switching voltage regulator circuits, four H-bridge drivers, and a reset circuit in a single IC. All 34920 control lines are compatible with CMOS type 3.3 V and 5.0 V logic.

#### SWITCHING VOLTAGE REGULATOR CIRCUITS

Two switching voltage regulators provide the following voltages from an unregulated input of 21 V to 42 V DC. Both are buck-type switching regulators using a MOSFET (internal to the 34920), current sense resistor (internal to the 34920), Schottky diode (external to the 34920), external inductor, and filter capacitor.

- V1 Voltage Regulator – This regulator is programmable, has a duty cycle of 37%, and provides either 3.3 V (+5%/-4%) or 5.0 V (+5%/-4%) at a current of 10 mA (minimum) to 500 mA (maximum).
- V2 Voltage Regulator – This regulator has a programmable output voltage (by means of an external resistor divider network) in the range of 10 V to 15 V  $\pm 2\%$  with a VB+ supply voltage range of 21 V to 42 V.

The V2 voltage regulator is controlled by an Enable bit in the serial register that allows software to turn this regulator on

and off. However, the Enable bit does not effect the V1 voltage regulator. The Enable bit will disable the V2 voltage regulator and disable all motor driver circuits.

#### MOTOR DRIVERS

The two motor drivers can be selectable as either a bi-directional DC motor driver, with PWM control and peak currents of 2.4 A, or a bipolar step motor driver, with average current levels of 183 mA and 550 mA per phase, and quarter step mode capability. In step mode, both drivers are capable of being operated in the quarter step mode.

#### RESET GENERATION

The 34920 provides an output,  $\overline{\text{RESET}}$ , that drives an external reset signal to the system microprocessor and/or the system digital logic IC. This signal is an active low logic level signal that is derived by monitoring the level of the VB+ and V1\_FB pins.

When  $\overline{\text{RESET}}$  is asserted, either internally or from an external source, all 34920 motor driver outputs will be in their inactive states, and the serial input port will be loaded with the reset value.

### FUNCTIONAL INTERNAL BLOCK DESCRIPTION

#### INPUT POWER SUPPLY (V<sub>VB+</sub>)

The input voltage for the switching regulators and motor drivers. V<sub>VB+</sub> has a voltage range of 21 V to 42 V.

#### CMOS LOGIC LEVEL

CMOS logic level specifications are described on [page 6](#) of the Static Electrical Characteristics table.

#### 34920 INPUT

[Table 5](#), page [13](#), describes the 34920 input specifications.

#### SERIAL INPUT PORT

The 34920 provides a serial input port for bit depth of 13 bits of input. This port provides an interface between the 34920 and the digital controller IC. This port is write-only. The interface consists of three signal lines: chip select ( $\overline{\text{CS}}$ , active low), serial clock (SCLK), and serial data input (SDI).

The digital controller initiates a serial transfer by pulling low the chip select line ( $\overline{\text{CS}}$ ). It then generates 13 clock pulses on the SCLK pin while presenting the serial data on the serial data input (SDI). The 34920 presents the data on SDI one setup time ( $t_{\text{DSU}}$ ) before the rising edge of SCLK. The data is held constant for the data hold time ( $t_{\text{DHD}}$ ) beyond the SCLK rising edge. The data is shifted into the 34920 on the rising edge of SCLK. The least significant bit (LSB) is the first to be shifted out of the 34920 on the rising edge of SCLK, followed by the remaining bits to the last of the 13 bits, which is the most significant bit (MSB). The  $\overline{\text{CS}}$  line is then returned to a high state. The low-to-high transition of  $\overline{\text{CS}}$  will load the data into the internal 34920 input register, where all the inputs are presented to their appropriate functions in a parallel fashion.

**Note** The minimum off-time ( $\overline{\text{CS}}$  signal equal to logic [1]) for the  $\overline{\text{CS}}$  signal needs to be at least  $1.0 t_{\text{DSU}}$  delay +  $1.0 t_{\text{DHD}}$  delay. This will provide the time for the 34920 to clear the serial input data register (transfer the serial data in parallel to internal latches that use the data) and thereby avoid a data overrun condition and loss of data. See the serial input port timing data in the Dynamic Electrical Characteristics table, [page 9](#).

**Table 5. 34920 Input Specifications**

Name	Description
V1_FB	Voltage feedback for the V1 regulator.
VCC	VCC power input for internal use. The 34920 accepts either 3.3 V $\pm 10\%$ or 5.0 V $\pm 5\%$ for its logic voltage.
V2_FB	Voltage feedback for the V2 regulator.
$\overline{\text{CS}}$	Serial input register chip select input. Active low.
SCLK	Serial input register clock.
SDI	Serial input register serial data input.
DRxPWM	PWM input for the DC motor driver for either Driver 1 or Driver 2.
DRx_MODE	Selects mode of each motor driver. Step = 1/DC = 0.

**The following inputs are through the Serial Input Register**

V2_Enable	Enable bit to turn on and off the V2 regulator and the motor drivers. When low (= logic [0]), the V2 regulator and the motor drivers are turned off and the 34920 is placed in its lowest possible power state. V1 is not affected by the Enable bit.
DR1_CURR_I1_PHASEA	Second of two inputs that control the current level in the step motor Phase A winding (Driver 1/Step Mode).
DR1_CURR_I0_PHASEA	First of two inputs that control the current level in the step motor Phase A winding (Driver 1/Step Mode).
DR1_DIR_PH_A	Controls the direction of the current flow through Phase A of the step motor; i.e., logic [1] level causes conventional current flow from DR1A1 to DR1B1 (Driver 1/Step Mode).
DR1_CURR_I1_PHASEB	Second of two inputs that control the current level in the step motor Phase B winding (Driver 1/Step Mode).
DR1_CURR_I0_PHASEB	First of two inputs that control the current level in the step motor Phase B winding (Driver 1/Step Mode).
DR1_DIR_PH_B	Controls the direction of the current flow through Phase B of the step motor. A logic [1] level causes conventional current flow from DR1A2 to DR1B2 (Driver 1/Step Mode).
DR2_CURR_I1_PHASEA	Second of two inputs that control the current level in the step motor Phase A winding (Driver 2/Step Mode).
DR2_CURR_I0_PHASEA	One of two inputs that control the current level in the step motor Phase A winding (Driver 2/Step Mode).
DR2_DIR_PH_A	Controls the direction of the current flow through Phase A of the step motor. A logic [1] level causes conventional current flow from DR2A1 to DR2B1 (Driver 2/Step Mode).
DR2_CURR_I1_PHASEB	Second of two inputs that control the current level in the step motor Phase B winding (Driver 2/Step Mode).
DR2_CURR_I0_PHASEB	One of two inputs that control the current level in the step motor Phase B winding (Driver 2/Step Mode).
DR2_DIR_PH_B	Controls the direction of the current flow through Phase B of the step motor. A logic [1] level causes conventional current flow from DR2A2 to DR2B2 (Driver 2/Step Mode).

## SERIAL INPUT PORT BIT DEFINITIONS

Tables 6 through 9 define the bit definitions as they apply to the 13 bits of input that are brought into the 34920 through the serial input port. These signals are listed in bit order from LSB (first bit to be shifted in) to MSB (last bit to be shifted in).

**Table 6. Serial Input Port Definition for Step/Step Mode**

Name	Bit	Reset Value	Description
V2_Enable	1	1	Enable bit to turn on and off the V2 regulator and the motor drivers and place the 34920 in the minimum power consumption state.
SDR2_CURR_I1_PHASEB	2	1	Second of two inputs that control the current level in the SDR2 step motor Phase B winding.
SDR2_CURR_I0_PHASEB	3	1	One of two inputs that control the current level in the SDR2 step motor Phase B winding.
SDR2_DIR_PH_B	4	0	Controls the direction of the current flow through Phase B of the SDR2 step motor. A logic [1] level causes conventional current flow from PH_B+ (source) to PH_B- (sink).
SDR2_CURR_I1_PHASEA	5	1	Second of two inputs that control the current level in the SDR2 step motor Phase A winding.
SDR2_CURR_I0_PHASEA	6	1	One of two inputs that control the current level in the SDR2 step motor Phase A winding.
SDR2_DIR_PH_A	7	0	Controls the direction of the current flow through Phase A of the SDR2 step motor. A logic [1] level causes conventional current flow from PH_A+ (source) to PH_A- (sink).
SDR1_CURR_I1_PHASEB	8	1	Second of two inputs that control the current level in the SDR1 step motor Phase B winding.
SDR1_CURR_I0_PHASEB	9	1	One of two inputs that control the current level in the SDR1 step motor Phase B winding.
SDR1_DIR_PH_B	10	0	Controls the direction of the current flow through Phase B of the SDR1 step motor. A logic [1] level causes conventional current flow from PH_B+ (source) to PH_B- (sink).
SDR1_CURR_I1_PHASEA	11	1	Second of two inputs that control the current level in the SDR1 step motor Phase A winding.
SDR1_CURR_I0_PHASEA	12	1	One of two inputs that control the current level in the SDR1 step motor Phase A winding.
SDR1_DIR_PH_A	13	0	Controls the direction of the current flow through Phase A of the SDR1 step motor. A logic [1] level causes conventional current flow from PH_A+ (source) to PH_A- (sink).

**Table 7. Serial Input Port Definition for DC Motor/DC Motor Mode <sup>(9)</sup>**

Name	Bit	Reset Value	Description
V2_Enable	1	1	Enable bit to turn on and off the V2 regulator and the motor drivers and place the 34920 in the minimum power consumption state.
Not Used	2	X	Not used in this mode.
Not Used	3	X	Not used in this mode.
Not Used	4	X	Not used in this mode.
Not Used	5	X	Not used in this mode.
Not Used	6	X	Not used in this mode.
DR2_DIR_DCM	7	0	Controls the direction of the current flow through the DC motor. A logic [1] level causes conventional current flow from DR2A1 (source)/DR2A2 (source) to DR2B1 (sink)/DR2B2 (sink).
Not Used	8	X	Not used in this mode.
Not Used	9	X	Not used in this mode.
Not Used	10	X	Not used in this mode.
Not Used	11	X	Not used in this mode.
Not Used	12	X	Not used in this mode.
DR1_DIR_DCM	13	0	Controls the direction of the current flow through the DC motor. A logic [1] level causes conventional current flow from DR1A1 (source)/DR1A2 (source) to DR1B1 (sink)/DR1B2 (sink).

Notes

- DR1\_MODE and DR2\_MODE pins = logic [0] for DC motor drive for both drivers.

**Table 8. Serial Input Port Definition for DR1=Step/DR2=DC Motor Mode**

Name	Bit	Reset Value	Description
V2_Enable	1	1	Enable bit to turn on and off the V2 regulator and the motor drivers and place the 34920 in the minimum power consumption state.
Not Used	2	X	Not used in this mode.
Not Used	3	X	Not used in this mode.
Not Used	4	X	Not used in this mode.
Not Used	5	X	Not used in this mode.
Not Used	6	X	Not used in this mode.
DR2_DIR_DCM	7	0	Controls the direction of the current flow through the DC motor. A logic [1] level causes conventional current flow from DR2A1 (source)/DR2A2 (source) to DR2B1 (sink)/DR2B2 (sink).
SDR1_CURR_I1_PHASEB	8	1	Second of two inputs that control the current level in the SDR1DR1 step motor Phase B winding.
SDR1_CURR_I0_PHASEB	9	1	One of two inputs that control the current level in the SDR1 step motor Phase B winding.
SDR1_DIR_PH_B	10	1	Controls the direction of the current flow through Phase B of the SDR1 step motor. A logic [1] level causes conventional current flow from PH_B+ (source) to PH_B- (sink).
SDR1_CURR_I1_PHASEA	11	0	Second of two inputs that control the current level in the SDR1 step motor Phase A winding.
SDR1_CURR_I0_PHASEA	12	1	One of two inputs that control the current level in the SDR1 step motor Phase A winding.
SDR1_DIR_PH_A	13	1	Controls the direction of the current flow through Phase A of the SDR1 step motor. A logic [1] level causes conventional current flow from PH_A+ (source) to PH_A- (sink).



**Table 9. Serial Input Port Definition for DR1=DC Motor/DR2=Step Mode**

Name	Bit	Reset Value	Description
V2_Enable	1	1	Enable bit to turn on and off the V2 regulator and the motor drivers and place the 34920 in the minimum power consumption state.
SDR2_CURR_I1_PHASEB	2	1	Second of two inputs that control the current level in the SDR2 step motor Phase B winding.
SDR2_CURR_I0_PHASEB	3	1	One of two inputs that control the current level in the SDR2 step motor Phase B winding.
SDR2_DIR_PH_B	4	0	Controls the direction of the current flow through Phase B of the SDR2 step motor. A logic [1] level causes conventional current flow from PH_B+ (source) to PH_B+ (sink).
SDR2_CURR_I1_PHASEA	5	1	Second of two inputs that control the current level in the SDR2 step motor Phase A winding.
SDR2_CURR_I0_PHASEA	6	1	One of two inputs that control the current level in the SDR2 step motor Phase A winding.
SDR2_DIR_PH_A	7	0	Controls the direction of the current flow through Phase A of the SDR2 step motor. A logic [1] level causes conventional current flow from PH_A+ (source) to PH_A- (sink).
Not Used	8	X	Not used in this mode.
Not Used	9	X	Not used in this mode.
Not Used	10	X	Not used in this mode.
Not Used	11	X	Not used in this mode.
Not Used	12	X	Not used in this mode.
DR1_DIR_DCM	13	0	Controls the direction of the current flow through the DC motor. A logic [1] level causes conventional current flow from DR1A1 (source)/DR1A2 (source) to DR1B1 (sink)/DR1B2 (sink).

## VOLTAGE REGULATORS

The 34920 contains two switching voltage regulators (see [Figure 6](#)). Both are buck-type voltage regulators using an internal switching MOSFET. The V1 regulator provides either 3.3 V or 5.0 V at +5%/-4% tolerance. The V2 regulator's output voltage,  $V_{V2}$ , is programmable through the use of an external resistor divider network. The voltage tolerance on the  $V_{V2}$  output is  $\pm 2\%$  of the nominal voltage set point. The switching frequency of the V1 and V2 regulators is approximately 200 kHz.

The V1 and V2 regulators are designed with a dual-mode current limit circuit. The current limit threshold is lowered during the power-on period to allow for a softer start-up, thereby reducing electrical stress in the external components.

$V_{VB+}$ , the input voltage for the switching voltage regulators, ranges from 21 V to 42 V. To minimize the ripple current on  $V_{VB+}$ , the V1 regulator and the V2 regulator switch out of phase.

A boost voltage generator (VB generator), which acts as a single-stage charge pump, provides gate drive voltage for the switching regulators. It uses an external capacitor to store the charge.

Output voltages  $V_{V1}$  and  $V_{V2}$  are set externally with a resistor (1% tolerance) divider network. Input voltages at V1\_FB and V2\_FB should be chosen to provide a feedback voltage, for the required output regulated voltage, to equal the internal regulator reference voltages of 2.5 V  $\pm 2\%$ .

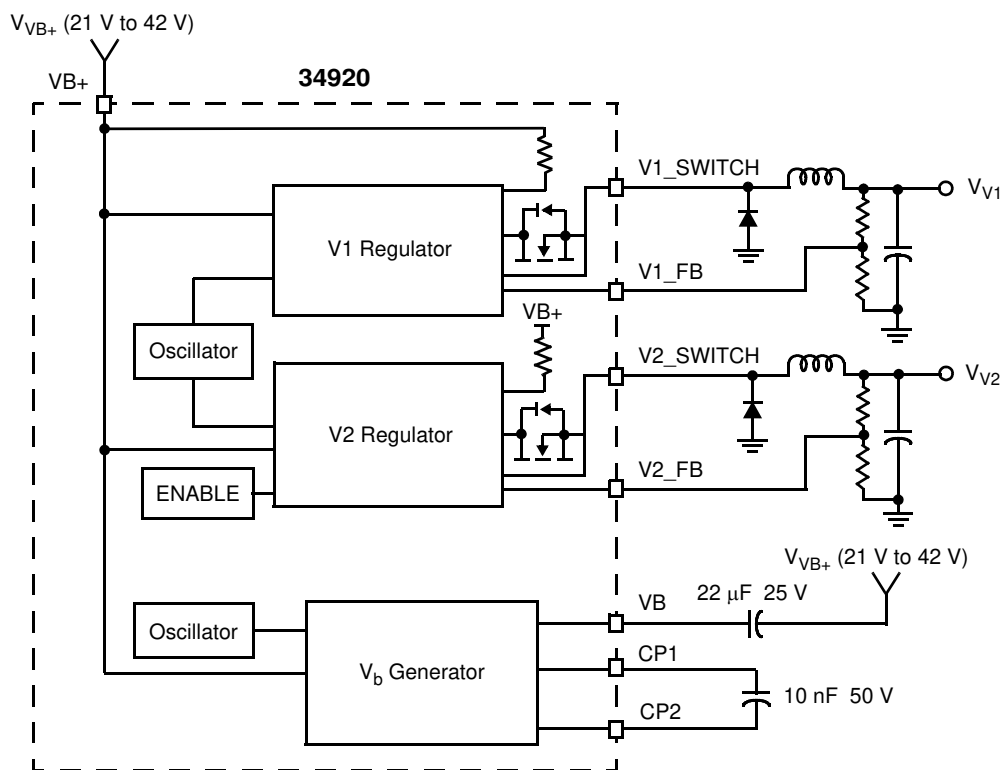

Figure 6. Voltage Regulator Functions

## VOLTAGE REGULATOR OUTPUT REQUIREMENTS

Table 10 provides a listing of the output voltages and currents. Both switchmode converters operate at approximately 200 kHz  $\pm$ 25 kHz.

Table 10. Voltage Regulator Output Requirements

Voltage Name	Minimum Voltage	Maximum Voltage	Load Range
$V_{V1}$	-4.0% of Nominal	+4.0% of Nominal	10 mA Min, 500 mA Max DC
$V_{V2}$ <sup>(10)</sup>	-2.0% of Nominal	+2.0% of Nominal	10 mA Min, 1.3 A Max DC <sup>(11)</sup>

### Notes

10. This voltage is programmable within a range of 10 V to 15 V via external resistors. The voltage tolerance around any set point is  $\pm$ 2% of the nominal.
11. Maximum peak duration is 400 ms.

The V1 and V2 regulators provide individual internal over-temperature sensing for protection. During an overtemperature event, when the device  $T_J$  is at or above  $T_{J(\text{SHUTDOWN})}$ , the internal thermal protection circuit disables the drive outputs by driving all outputs to the zero current state until the device temperatures have dropped below the lower thermal threshold temperature  $T_{J(\text{ENABLE})}$ , at which time the driver is re-enabled.

The V1 and V2 voltage regulators may be shut down by applying a voltage in the range of 3.0 V to 6.0 V to the

respective V1\_FB and V2\_FB pins. This will result in the regulator output voltages to be equal to 0 V.

## OVERCURRENT PROTECTION

Output voltages  $V_{V1}$  and  $V_{V2}$  are short circuit protected. The outputs respond to an overcurrent situation by limiting the internal switching duty cycle. This can be reset by removing the main supply to the chip or when the short circuit condition is removed. Refer to the respective  $I_{OC}$  and  $I_{SC}$

values for V1 and V2 voltage regulators on [page 6](#) of the Static Electrical Characteristics table.

## POWER-SAVING MODE OF OPERATION

The V2 voltage regulator can be disabled via the serial interface by setting the V2\_Enable bit (bit 1 –LSB) to a value of 0. This provides a reduction in the bias current provided by the V1 supply.

## V1 VOLTAGE REGULATOR

Implementation of the V1 switching voltage regulator is accomplished through the use of an internal switch MOSFET, internal MOSFET current sense resistor, external Schottky diode, external inductor, and filter capacitor. The frequency of operation of this regulator is controlled by the internal clock, which is 200 kHz  $\pm$ 25 kHz. The duty cycle (on-time) for this internal regulator clock is a fixed 37.5%. This regulator switches out of phase from the V2 regulator to minimize ripple current on VB+. The line regulation range is 21 V <  $V_{VB+}$  < 42 V. The load side regulation is specified on [page 6](#) of the Static Electrical Characteristics table.

This converter is designed so that the current limit threshold is lowered during the power-on period to allow for a “softer” start-up, thereby reducing electrical stress in the external components. This limiting is required for their safe operation.

The voltage is set externally with a resistor (1% tolerance) divider network. The V1\_FB input voltage should be chosen, using external voltage divider resistors, so as to provide a regulator feedback voltage, for the required output regulated voltage, to equal the internal regulator reference voltage of 2.50 V  $\pm$ 2%. The V1 regulator is ideal for providing either 3.3 V or 5.0 V with a precision of +5%/-4%.

Output current sensing is implemented by sensing the voltage across an internal sense resistor connected between VB+ and the drain of the internal MOSFET. Current is measured on a cycle-by-cycle basis. The purpose of this current sense is to prevent damage to the 34920 and its associated external components.

## V2 VOLTAGE REGULATOR

The V2 switching voltage regulator is implemented as a buck regulator with an internal switch MOSFET, internal MOSFET current sense resistor, external Schottky diode, external inductor, and filter capacitor. The frequency of operation of this regulator is controlled by the internal clock, which is 200 kHz  $\pm$ 25 kHz. This regulator switches out of

phase from the V1 regulator to minimize ripple current on VB+.

This converter is designed so that the current limit threshold is lowered during the power-on period to allow for a “softer” start-up, thereby reducing electrical stress in the external components. This limiting is required for their safe operation.

The output voltage is variable with  $\pm$ 2% precision, with a  $V_{VB+}$  supply voltage range of 21 V to 42 V. The exact voltage will be set externally with a resistor (1% tolerance) divider network. The V2\_FB input voltage should be chosen, using external voltage divider resistors, so as to provide a regulator feedback voltage, for the required output regulated voltage, to equal the internal regulator reference voltages of 2.50 V  $\pm$ 2%.

Output current sensing is implemented by sensing the voltage across an internal sense resistor connected between VB+ and the drain of the internal MOSFET. Current is measured on a cycle-by-cycle basis. The purpose of this current sense is to prevent any damage to the 34920 and its associated external components.

**Note** There is a V2\_Enable bit in the Serial Communication Input register (bit 1). When this bit is set to logic [1], the V2 voltage regulator is enabled. When this bit = logic [0], the V2 voltage regulator is disabled. Refer to [Tables 5](#) through [9](#), pp. [13](#)–[17](#), for a description of this bit. The V2\_Enable bit will also disable the motor drivers.

## VB GENERATOR

The boost voltage generator circuit is a charge pump circuit using two external capacitors to provide the necessary voltage to drive internal 34920 loads. This circuit is driven at a frequency of 200 kHz  $\pm$ 25 kHz.

The VB generator is utilized exclusively by the 34920. There is no provision for external loading. Also, there is no disable feature for the VB generator.

## MOTOR DRIVE SYSTEMS

The 34920 provides two motor drivers. Both drivers are mode selectable to be either a multi-current level bi-directional driver for bipolar step motors or a bi-directional DC motor driver with PWM control. The DR1\_MODE (Mode1) and DR2\_MODE (Mode2) pins select whether the appropriate motor driver will drive a step motor (pin = 1) or DC motor (pin = 0). [Figures 7](#) and [8](#) depict the two motor configurations.

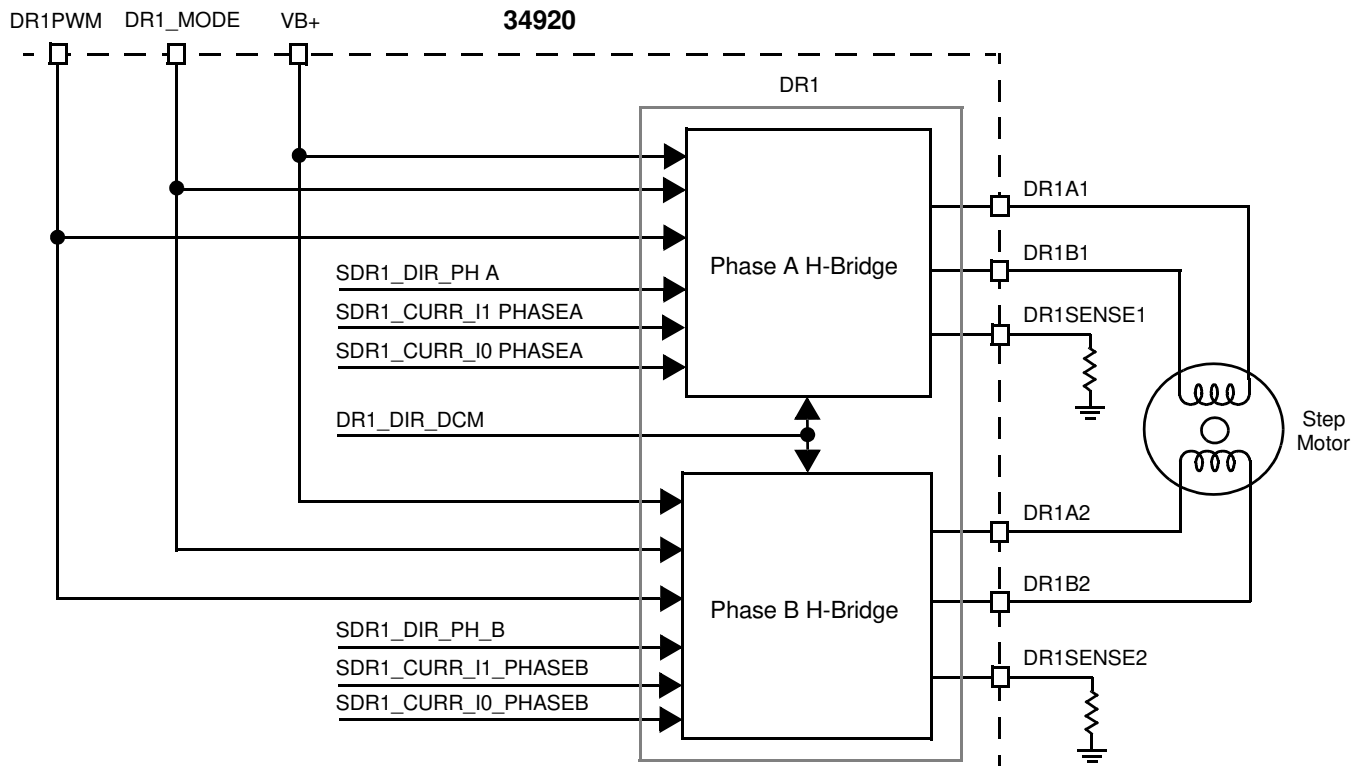

Figure 7. Simplified Step Application Diagram Showing 1 of 2 Step Drive Circuits

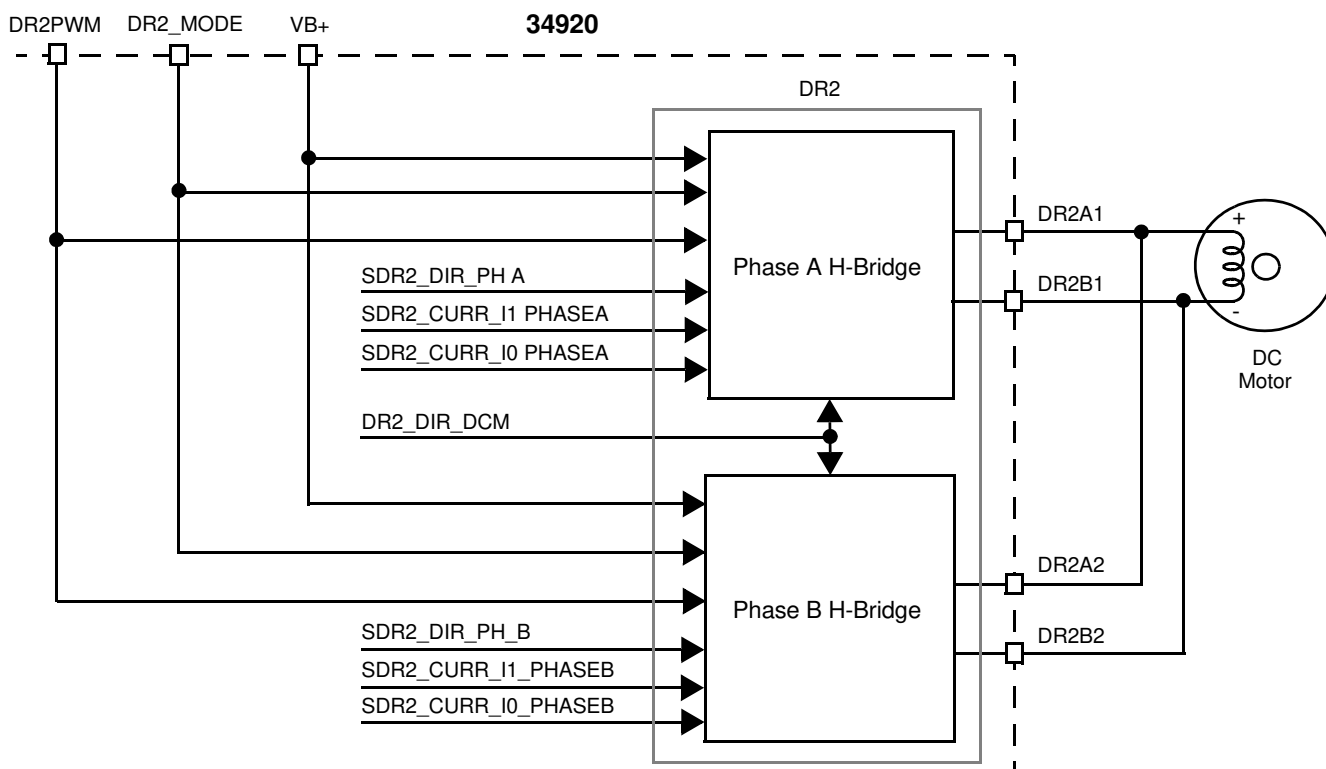

Figure 8. Simplified DC Application Diagram Showing 1 of 2 Motor Drive Circuits

### BIPOLAR CURRENT REGULATED STEP MOTOR DRIVE SYSTEM

The drive circuitry is powered by the  $V_{VB+}$  supply voltage. For example, with external current sense resistors of  $0.910 \Omega \pm 1\%$ , the drive circuitry provides drive for a bipolar step motor at current levels of approximately 183 mA, 367 mA, and 550 mA. Current mode operation supports quarter stepping.

This drive enters the fast current decay mode when both the  $CURR\_I0\_PHASEX$  and  $CURR\_I1\_PHASEX$  inputs are set to the logic [1] level. In fast current decay mode, any residual motor winding current is forced into the  $V_{VB+}$  supply rail when going to a zero current state from a non-zero current level. This forces the motor winding current toward zero as quickly as possible.

For each of the two H-bridge drivers, controlled crossover delay, a blanking period, and internal overtemperature sensing are provided. The crossover delay is controlled to provide sufficient time for cross-conduction suppression. At

no time will both the upper and lower output device on the same side of the H-bridge be allowed to conduct simultaneously. Also, following a turn-on event a blanking period is included to prevent false turn-offs owing to the initial turn-on current spike, which results from motor circuit capacitance.

This drive has internal overtemperature sensing for protection. During an overtemperature event, when the device  $T_J$  is at or above  $T_{J(SHUTDOWN)}$ , the internal thermal protection circuit disables the drive outputs by driving all outputs to the zero current state until the device temperatures have dropped below the lower thermal threshold temperature  $T_{J(ENABLE)}$ , at which time the driver is re-enabled.

**Note** During power-on the step motor driver circuit inhibits its outputs when  $V_{VB+}$  is at 4.0 V or greater until  $\overline{RESET}$  is released. Likewise, during power-down the step motor driver circuit inhibits its outputs from the point when  $\overline{RESET}$  goes low until  $V_{VB+}$  has dropped below 4.0 V.

## DC MOTOR DRIVE SYSTEM

This drive circuitry provides bi-directional drive to a DC motor via two inputs, DCM\_PWM (an external pin, CMOS-compatible input) and DRx\_DIR\_DCM (a bit in the serial input port; refer to [Tables 7](#) through [9](#), pp. 15–17). This drive is powered from VB+. The DC motor control circuitry uses voltage mode control.

To drive a DC motor the 34920 outputs DR2A1 and DR2A2 must be connected together externally, then connected to the DC motor “+” lead. Likewise, the 34920 outputs DR2B1 and DR2B2 must be connected together externally, then connected to the DC motor “-” lead (see [Figure 8](#)).

This drive provides internal overtemperature sensing for protection. During an overtemperature event, when the device  $T_J$  is at or above  $T_{J(\text{SHUTDOWN})}$ , the internal thermal protection circuit disables the drive outputs by driving both outputs to the high state until the device temperatures have dropped below the lower thermal threshold temperature  $T_{J(\text{ENABLE})}$ , at which time the drive is re-enabled.

The crossover delay must be controlled to provide sufficient time for cross-condition suppression. At no time can both the upper and lower output devices on the same side of the H-bridge be allowed to conduct simultaneously. Also, following a turn-on event a blanking period is included to prevent false turn-offs owing to the initial turn-on current spike, which results from motor circuit capacitance.

**Note** During power-on the DC Motor Driver circuit inhibits its outputs when  $V_{VB+}$  is at 4.0 V or greater until  $\overline{\text{RESET}}$  is released. Likewise, during power-down of the machine the DC Motor Driver circuit inhibits its outputs from the point when  $\overline{\text{RESET}}$  goes low until  $V_{VB+}$  has dropped below 4.0 V.

## RESET FUNCTIONALITY

The 34920 provides an output,  $\overline{\text{RESET}}$ , that drives an external reset signal to the system microprocessor and/or the system digital logic IC. This signal is an active low logic level signal that is derived by monitoring the level of the  $V_{CC}$  pin. This output is the equivalent of an open drain- (or open collector-) type output, with an internal 2.5 k $\Omega$  pull-up to  $V_{CC}$ . This output pin can be driven by other external sources and therefore the state of  $\overline{\text{RESET}}$  must be monitored by the 34920.

**Note** When  $\overline{\text{RESET}}$  is asserted either internally or from an external source, all 34920 motor drive outputs will be in their inactive states, and the serial input port will be loaded with the “Reset Value” (refer to [Tables 6](#) through [9](#)). The V2 voltage regulator will be enabled.

During power-up this output asserts a logic low level, and it monitors the V1 regulator output voltage and detects the point that it reaches  $V_{V1T+}$ . The output will then remain low for a delay of 15 ms to 50 ms before releasing to a high state. A second case is if  $V_{V1\_FB}$  is at or above  $V_{V1T+}$  for a period

longer than the delay period of  $t_{\text{DELAY}}$  and  $V_{VB+}$  is still less than  $V_{VB+T-}$ . In this situation  $\overline{\text{RESET}}$  will remain low until  $V_{VB+}$  is greater than  $V_{VB+T-}$ , at which point  $\overline{\text{RESET}}$  will be released immediately and there will be no delay period. If  $V_{VB+}$  passes through  $V_{VB+T+}$  during the  $t_{\text{DELAY}}$  period,  $\overline{\text{RESET}}$  will remain low until the end of the  $t_{\text{DELAY}}$  period, which started at the time  $V_{V1\_FB}$  passed through the  $V_{V1T+}$  level.

During power-down this output immediately asserts a logic low at the point when  $V_{V1\_FB}$  drops down to the trip point of  $V_{V1T-}$ . Also, if  $V_{VB+}$  drops below  $V_{VB+T-}$  and  $V_{V1\_FB}$  is still at or above  $V_{V1T-}$ ,  $\overline{\text{RESET}}$  will be pulled low.

## RESET BEHAVIOR

The following conditions describe the behavior of the  $\overline{\text{RESET}}$  circuit.

**A Note on Terminology** Assertion of  $\overline{\text{RESET}}$  is defined as the  $\overline{\text{RESET}}$  pin outputting a logic low voltage, and de-assertion is when the pin is pulled up to the  $V_{CC}$  voltage.

On the power-up condition,  $\overline{\text{RESET}}$  behaves as follows:

- If  $1.0 \text{ V} < V_{V1\_FB} < V_{V1T+}$  or  $V_{VB+} < V_{VB+T+}$ ,  $\overline{\text{RESET}}$  will be asserted.  
**Important** If  $V_{V1\_FB} < 1.0 \text{ V}$ ,  $\overline{\text{RESET}}$  is undefined.
- If  $\overline{\text{RESET}}$  is asserted owing to  $V_{V1\_FB} < V_{V1T-}$ , then when  $V_{V1\_FB}$  rises monotonically from below  $V_{V1T-}$  to above  $V_{V1T+}$ ,  $\overline{\text{RESET}}$  will de-assert after a duration of  $t_{\text{DELAY}}$ .
- If  $\overline{\text{RESET}}$  is asserted owing to  $V_{VB+} < V_{VB+T+}$  and  $V_{V1\_FB} \geq V_{V1T+}$ , then when  $V_{VB+}$  rises to the  $V_{VB+T+}$  level  $\overline{\text{RESET}}$  will de-assert with no delay. The only case where a delay would be seen is if the time period from where  $V_{V1\_FB}$  rises to the  $V_{V1T+}$  level to the point where  $V_{VB+}$  rises to the  $V_{VB+T+}$  level is less than the  $t_{\text{DELAY}}$  period. Then the delay in de-asserting  $\overline{\text{RESET}}$  would be the remaining  $t_{\text{DELAY}}$  time, thereby maintaining the full  $t_{\text{DELAY}}$  period, between the time when  $V_{V1\_FB}$  reaches  $V_{V1T+}$  and the de-assertion of  $\overline{\text{RESET}}$ , that is required for a reliable system reset.

On the power-down condition,  $\overline{\text{RESET}}$  behaves as follows:

- If  $\overline{\text{RESET}}$  is not asserted, and the  $V_{V1\_FB}$  voltage monotonically decreases to a value below the negative-going threshold of  $V_{V1T-}$  and remains below  $V_{V1T-}$  for longer than  $t_{\text{PERSIST}}$  (10  $\mu\text{s}$  to 30  $\mu\text{s}$ ),  $\overline{\text{RESET}}$  will be asserted.  $\overline{\text{RESET}}$  will remain asserted while  $1.0 \text{ V} < V_{V1\_FB} < V_{V1T+}$ . If  $V_{V1\_FB}$  falls below 1.0 V, the  $\overline{\text{RESET}}$  signal is undefined.
- $\overline{\text{RESET}}$  will also be asserted when  $V_{VB+}$  decreases below the  $V_{VB+T+}$  level. This will occur even if the  $V_{V1\_FB}$  level is still above  $V_{V1T-}$ .

On the  $V_{V1\_FB}$  glitch condition,  $\overline{\text{RESET}}$  behaves as follows:

- If the  $V_{V1\_FB}$  supply falls below  $V_{V1T}$  and remains there for less than  $t_{\text{PERSIST}}$  (10  $\mu\text{s}$  to 30  $\mu\text{s}$ ),  $\overline{\text{RESET}}$  will not be asserted. However, if the condition lasts longer than  $t_{\text{PERSIST}}$ ,  $\overline{\text{RESET}}$  will be asserted for a duration of  $t_{\text{DELAY}}$ . The 10  $\mu\text{s}$ -to-30  $\mu\text{s}$  persistence time specified in  $t_{\text{PERSIST}}$  is for ESD rejection. The reset trigger will be a retriggerable one-shot, where the delay pulse will be 10  $\mu\text{s}$  to 30  $\mu\text{s}$  for the delay timeout.

## ENVIRONMENTAL SPECIFICATIONS

### AMBIENT TEMPERATURE AND RELATIVE HUMIDITY

[Table 11](#) lists the temperature and relative humidity for operating and storage conditions for the 34920.

**Table 11. Ambient Temperature and Humidity**

Condition	Temperature (°C)	% Relative Humidity
Operating	0 to 70	8.0 to 80
Storage	-40 to 150	5.0 to 80

### ESD IMMUNITY

Refer to the Maximum Ratings table, [page 5](#).

### OVERTEMPERATURE PROTECTION

The 34920 implements overtemperature detection and shutdown functions. The overtemperature circuitry monitors the device's internal temperature and activates thermal shutdown circuitry when the temperature exceeds  $T_{J(\text{SHUTDOWN})}$  (155°C minimum, 175°C maximum). The thermal shutdown condition is maintained until the die temperature falls below  $T_{J(\text{ENABLE})}$  (135°C minimum, 155°C maximum). Each voltage regulator and motor driver circuit has its own individual shutdown circuit.

## FUNCTIONAL DEVICE OPERATION

### LOGIC COMMANDS AND REGISTERS

Table 12. Step Motor Truth Table

DIR_PH_A	CURR_I0_PHASEA	CURR_I1_PHASEA	IPH_A (mA)	DIR_PH_B	CURR_I0_PHASEB	CURR_I1_PHASEB	IPH_B (mA)
0	0	0	550	0	0	0	550
0	1	0	367	0	1	0	367
0	0	1	183	0	0	1	183
X	1	1	Off	X	1	1	Off
1	0	0	-550	1	0	0	-550
1	1	0	-367	1	1	0	-367
1	0	1	-183	1	0	1	-183

Table 13. DC Motor Drive System Truth Table

DRx_DIR_DCM	DRxPWM	High-Side A	Low-Side A	High-Side B	Low-Side B
0	0	On	Off	On	Off
0	1	Off	On	On	Off
1	0	On	Off	On	Off
1	1	On	Off	Off	On





# PACKAGING

## PACKAGE DIMENSIONS

For the most current package revision, visit [www.freescale.com](http://www.freescale.com) and perform a keyword search using the "98A" listed below.

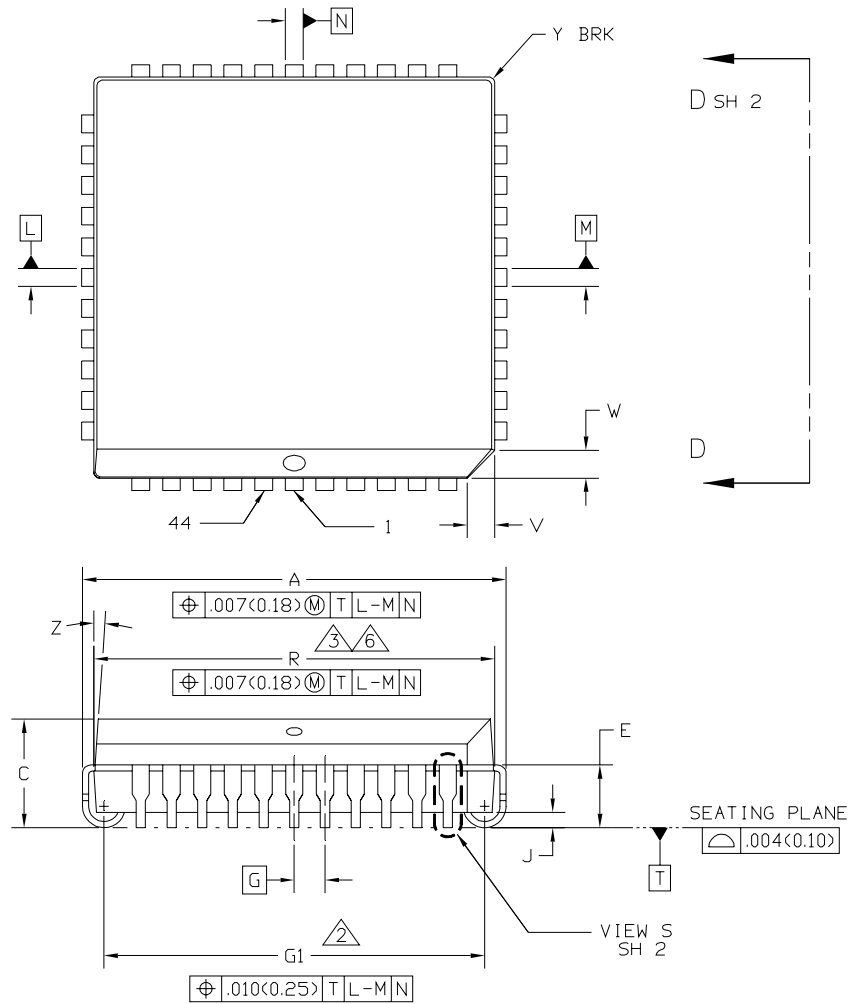

© FREESCALE SEMICONDUCTOR, INC. ALL RIGHTS RESERVED.	MECHANICAL OUTLINE	PRINT VERSION NOT TO SCALE	
TITLE: MOS/BI POLAR (44 LEAD) PLASTIC LEADED CHIP CARRIER	DOCUMENT NO: 98ASB42598B	REV: E	
	CASE NUMBER: 777-02	24 MAY 2005	
	STANDARD: NON-JEDEC		

**FN SUFFIX**  
EI-PIN  
PLASTIC PACKAGE  
98ASB42598B  
ISSUE E

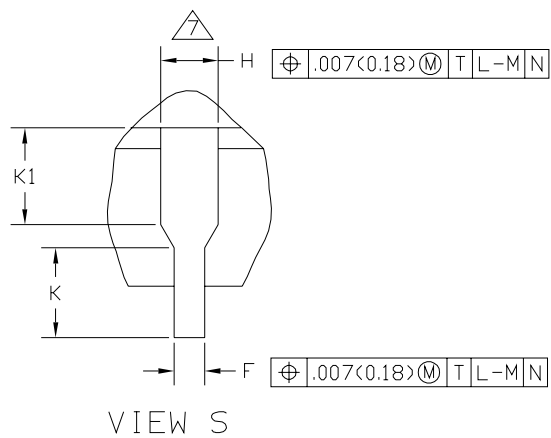
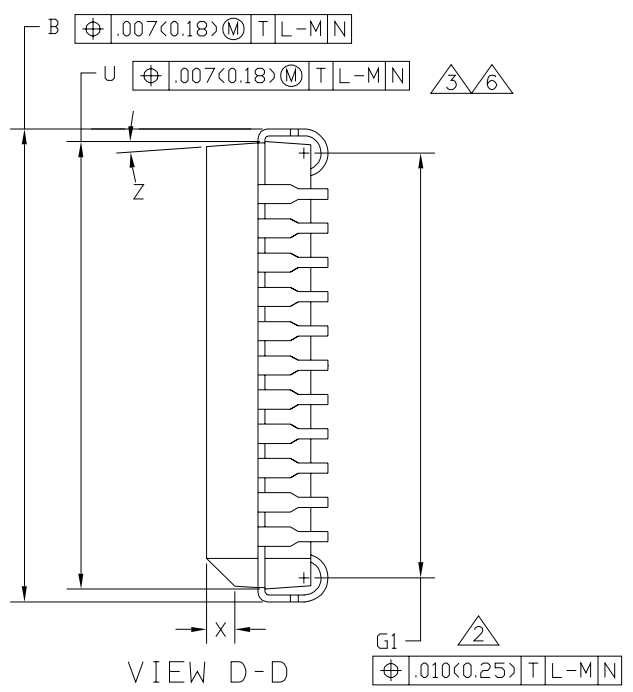

© FREESCALE SEMICONDUCTOR, INC. ALL RIGHTS RESERVED.	MECHANICAL OUTLINE	PRINT VERSION NOT TO SCALE	
TITLE: MOS/BI POLAR (44 LEAD) PLASTIC LEADED CHIP CARRIER	DOCUMENT NO: 98ASB42598B	REV: E	
	CASE NUMBER: 777-02	24 MAY 2005	
	STANDARD: NON-JEDEC		

**FN SUFFIX**  
EI-PIN  
PLASTIC PACKAGE  
98ASB42598B  
ISSUE E

## REVISION HISTORY

REVISION	DATE	DESCRIPTION OF CHANGES
2.0	8/2006	<ul style="list-style-type: none"><li>• Implemented Revision History page</li><li>• Converted to Freescale format and updated to the prevailing form and style</li><li>• Added EI Pb-FREE suffix</li></ul>

## **How to Reach Us:**

### **Home Page:**

[www.freescale.com](http://www.freescale.com)

### **E-mail:**

[support@freescale.com](mailto:support@freescale.com)

### **USA/Europe or Locations Not Listed:**

Freescale Semiconductor  
Technical Information Center, CH370  
1300 N. Alma School Road  
Chandler, Arizona 85224  
+1-800-521-6274 or +1-480-768-2130  
[support@freescale.com](mailto:support@freescale.com)

### **Europe, Middle East, and Africa:**

Freescale Halbleiter Deutschland GmbH  
Technical Information Center  
Schatzbogen 7  
81829 Muenchen, Germany  
+44 1296 380 456 (English)  
+46 8 52200080 (English)  
+49 89 92103 559 (German)  
+33 1 69 35 48 48 (French)  
[support@freescale.com](mailto:support@freescale.com)

### **Japan:**

Freescale Semiconductor Japan Ltd.  
Headquarters  
ARCO Tower 15F  
1-8-1, Shimo-Meguro, Meguro-ku,  
Tokyo 153-0064  
Japan  
0120 191014 or +81 3 5437 9125  
[support.japan@freescale.com](mailto:support.japan@freescale.com)

### **Asia/Pacific:**

Freescale Semiconductor Hong Kong Ltd.  
Technical Information Center  
2 Dai King Street  
Tai Po Industrial Estate  
Tai Po, N.T., Hong Kong  
+800 2666 8080  
[support.asia@freescale.com](mailto:support.asia@freescale.com)

### **For Literature Requests Only:**

Freescale Semiconductor Literature Distribution Center  
P.O. Box 5405  
Denver, Colorado 80217  
1-800-441-2447 or 303-675-2140  
Fax: 303-675-2150  
[LDCForFreescaleSemiconductor@hibbertgroup.com](mailto:LDCForFreescaleSemiconductor@hibbertgroup.com)

RoHS-compliant and/or Pb-free versions of Freescale products have the functionality and electrical characteristics of their non-RoHS-compliant and/or non-Pb-free counterparts. For further information, see <http://www.freescale.com> or contact your Freescale sales representative.

For information on Freescale's Environmental Products program, go to <http://www.freescale.com/epp>.

Information in this document is provided solely to enable system and software implementers to use Freescale Semiconductor products. There are no express or implied copyright licenses granted hereunder to design or fabricate any integrated circuits or integrated circuits based on the information in this document.

Freescale Semiconductor reserves the right to make changes without further notice to any products herein. Freescale Semiconductor makes no warranty, representation or guarantee regarding the suitability of its products for any particular purpose, nor does Freescale Semiconductor assume any liability arising out of the application or use of any product or circuit, and specifically disclaims any and all liability, including without limitation consequential or incidental damages. "Typical" parameters that may be provided in Freescale Semiconductor data sheets and/or specifications can and do vary in different applications and actual performance may vary over time. All operating parameters, including "Typicals", must be validated for each customer application by customer's technical experts. Freescale Semiconductor does not convey any license under its patent rights nor the rights of others. Freescale Semiconductor products are not designed, intended, or authorized for use as components in systems intended for surgical implant into the body, or other applications intended to support or sustain life, or for any other application in which the failure of the Freescale Semiconductor product could create a situation where personal injury or death may occur. Should Buyer purchase or use Freescale Semiconductor products for any such unintended or unauthorized application, Buyer shall indemnify and hold Freescale Semiconductor and its officers, employees, subsidiaries, affiliates, and distributors harmless against all claims, costs, damages, and expenses, and reasonable attorney fees arising out of, directly or indirectly, any claim of personal injury or death associated with such unintended or unauthorized use, even if such claim alleges that Freescale Semiconductor was negligent regarding the design or manufacture of the part.

Freescale™ and the Freescale logo are trademarks of Freescale Semiconductor, Inc. All other product or service names are the property of their respective owners.

© Freescale Semiconductor, Inc., 2007. All rights reserved.