

LOC	DIST	REVISIONS			
P	LTN	DESCRIPTION	DATE	DWN	APVD
A1		REVISED PER ECO-17-017667	05DEC2017	IT	SH

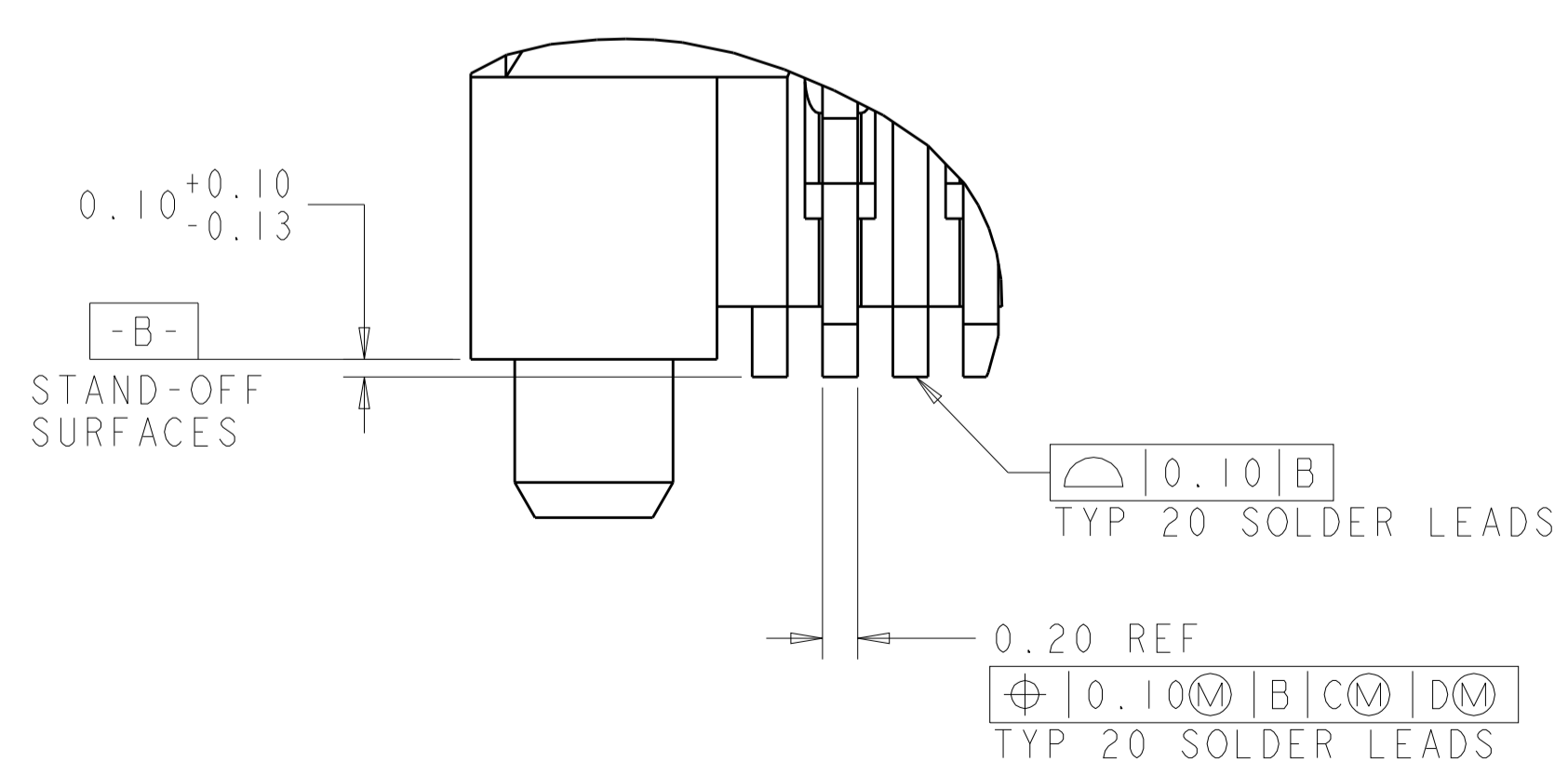
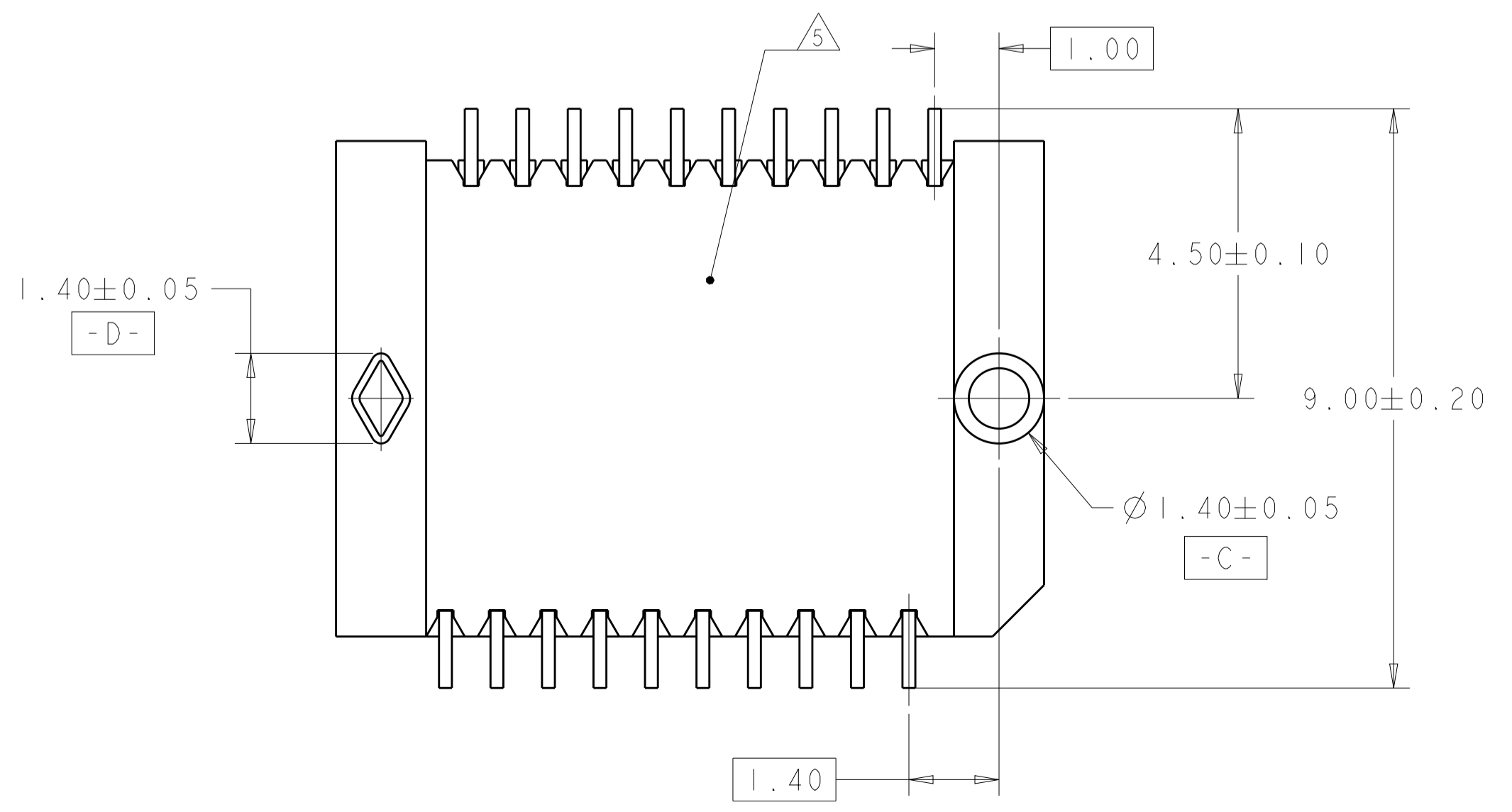
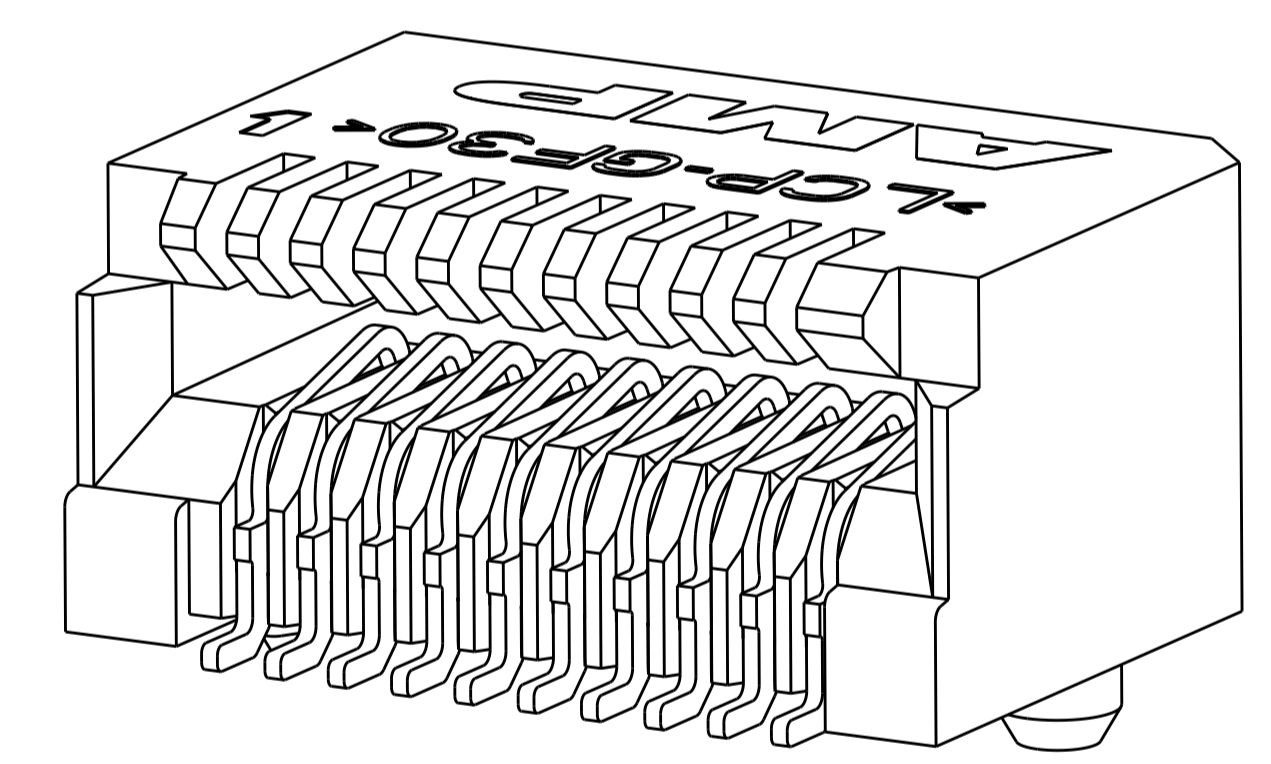
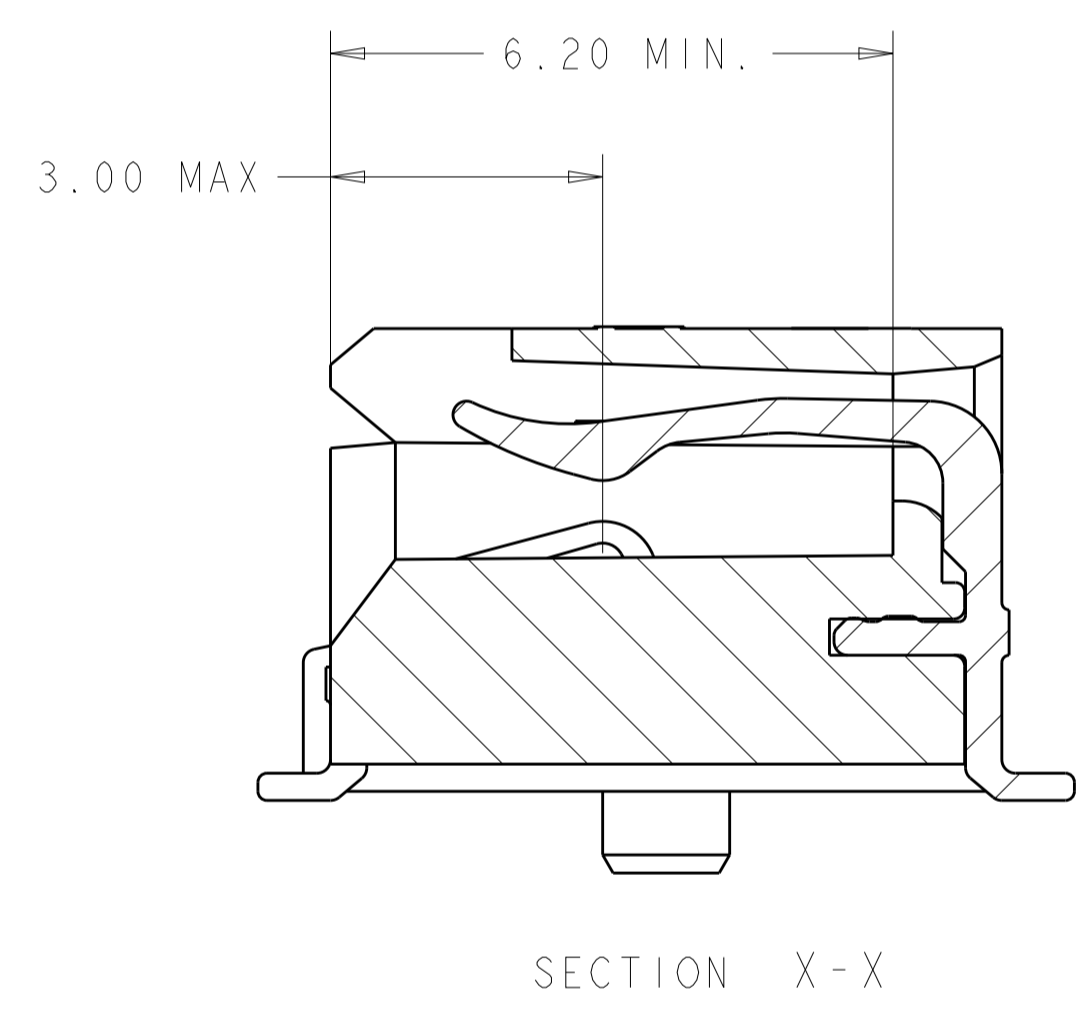
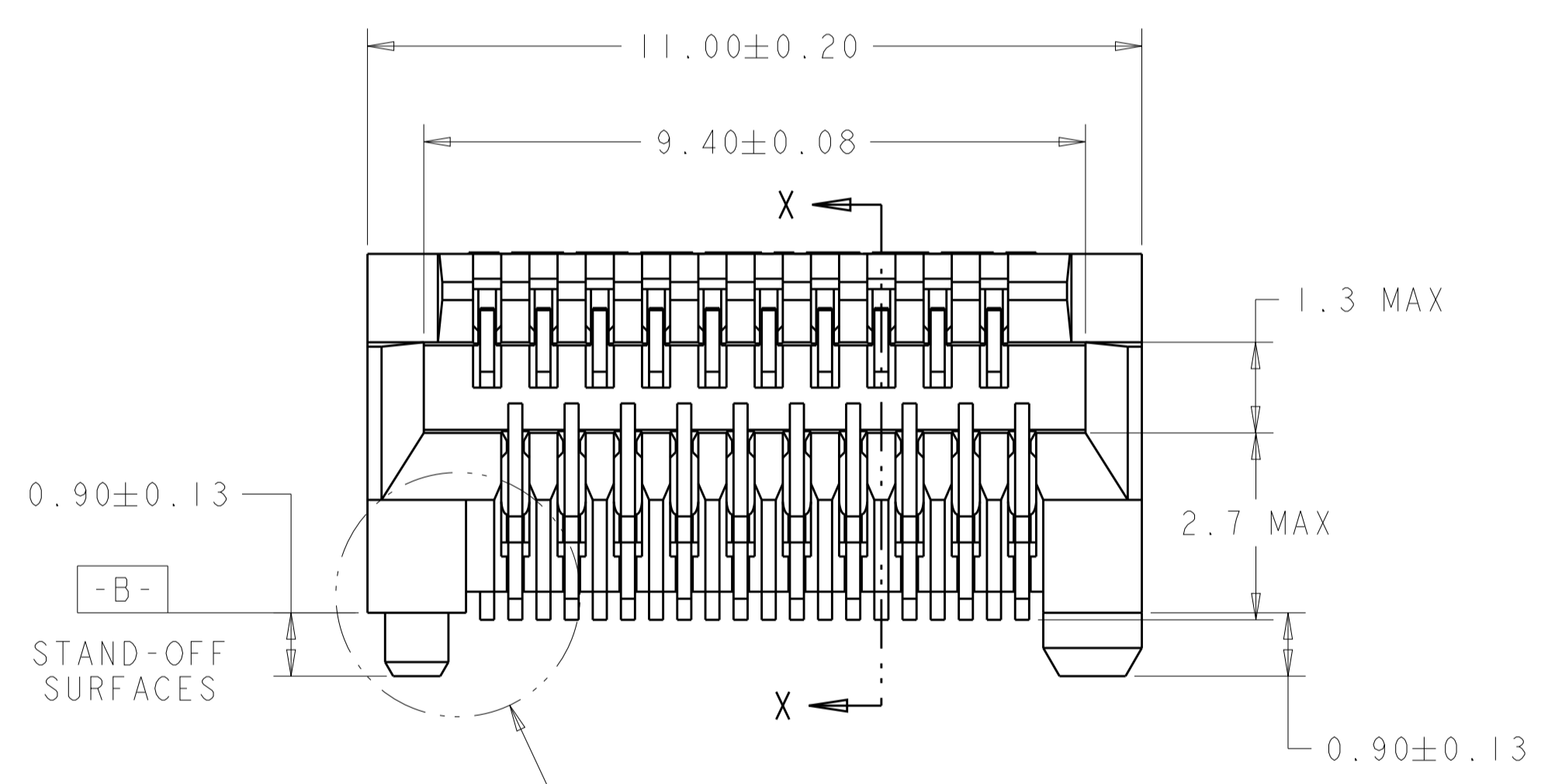
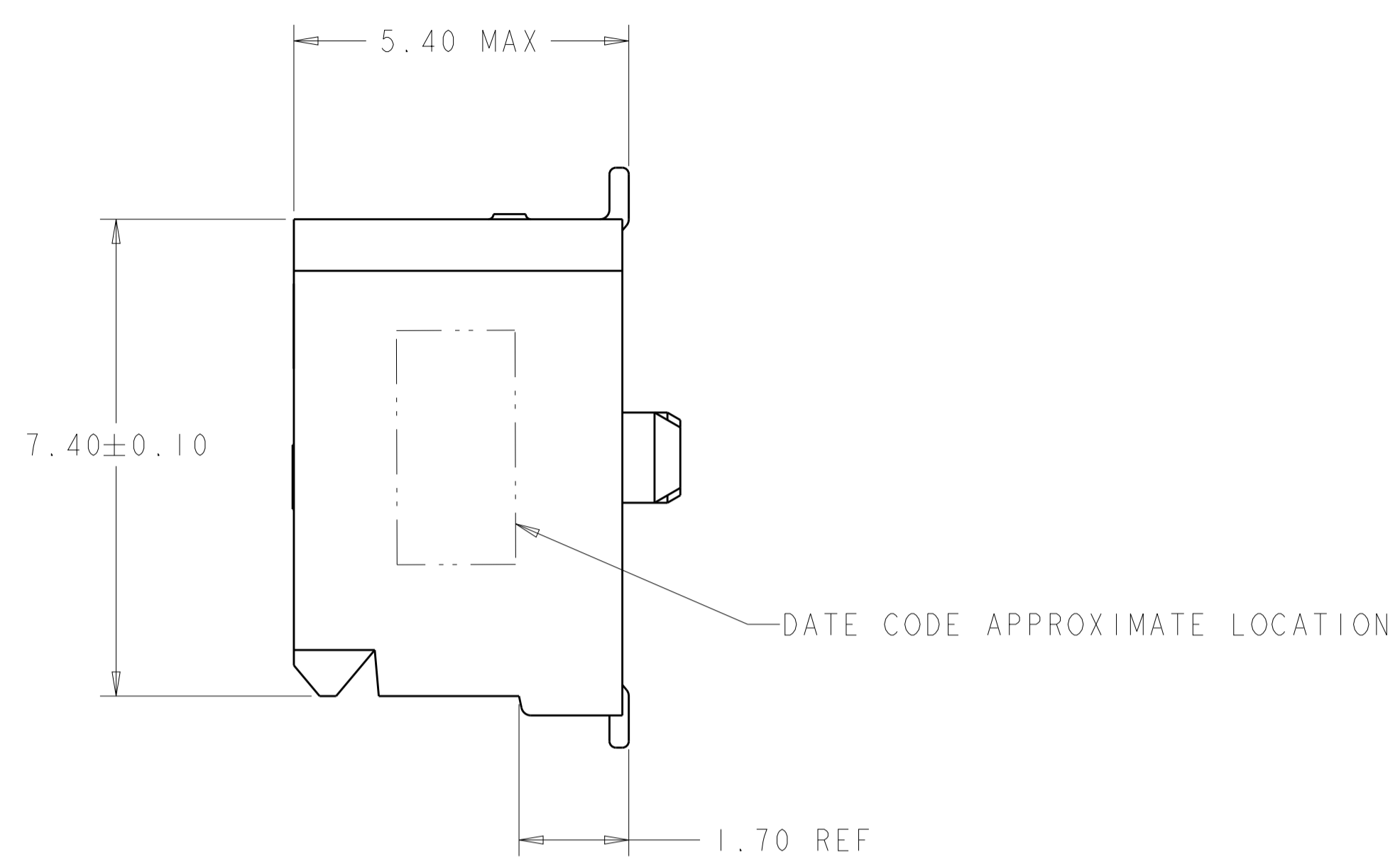
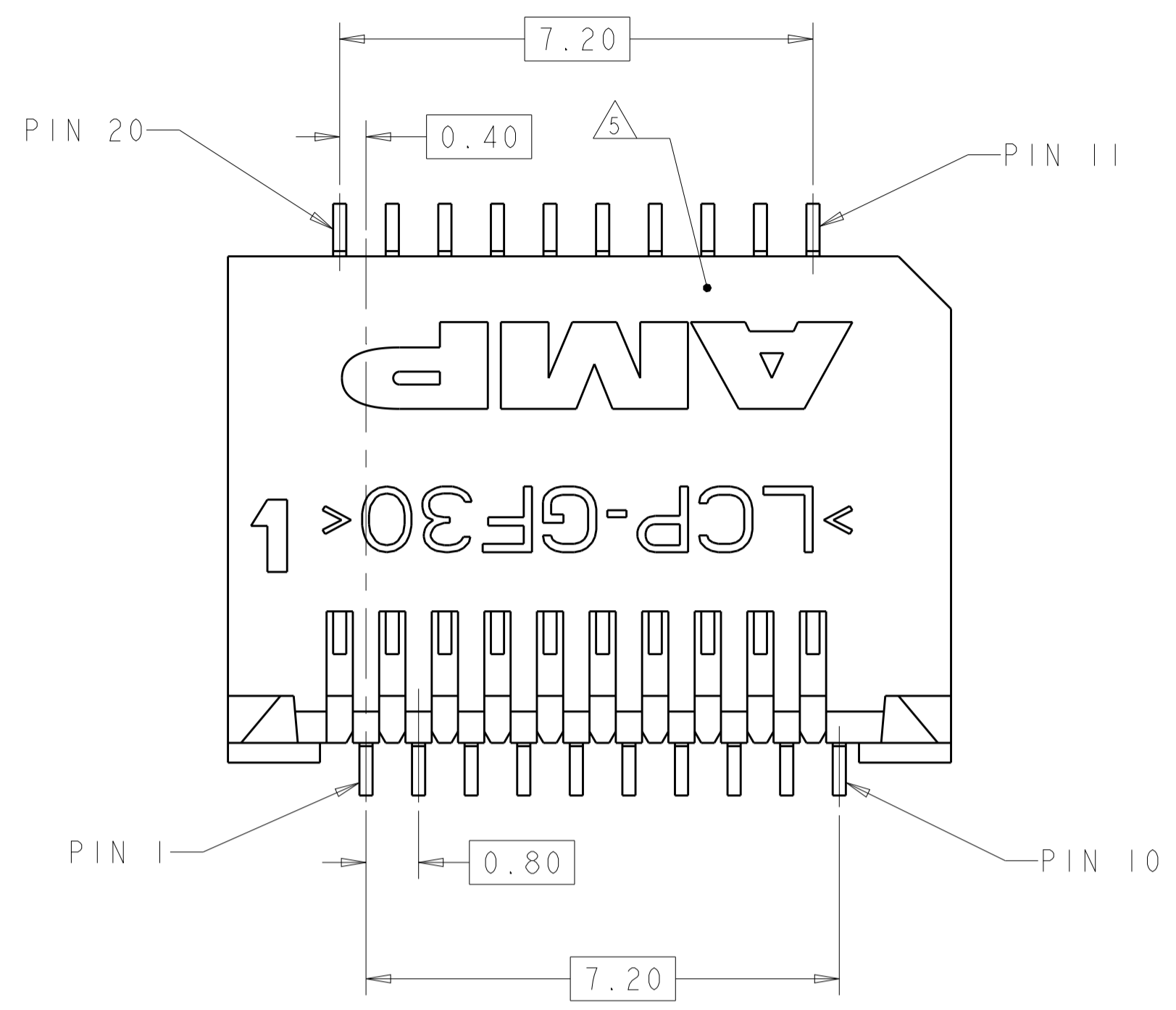

DETAIL H
SCALE 25:1

- 1 MATERIAL:
HOUSING: HIGH TEMPERATURE LCP, UL 94V-0 RATED, BLACK
CONTACTS: PHOSPHOR BRONZE.
- 2 FINISH:
CONTACTS: 0.76 μm MIN GOLD ON CONTACT AREA, 0.13 μm
MIN GOLD ON SOLDER AREA. ALL OVER 1.27 μm MIN NICKEL
UNDERPLATE ON ENTIRE CONTACT. LUBRICANT ON GOLD PLATE
CONTACT AREAS.
- 3. PACKAGED 480 PIECES PER REEL.
- 4 DATUMS AND BASIC DIMENSIONS TO BE ESTABLISHED BY
CUSTOMER; SEE DRAWING 1367034 FOR LAYOUT WHEN USED
WITH 1367034-1 BOTTOM CAGE (STANDARD SFP APPLICATION).
- 5 PULL GROOVES PERMITTED ON THESE SURFACES AT MOLDING
ENGINEERING DISCRETION

YES	△	2170184-2
NO	△	2170184-1
DATE CODE	FINISH	PART NUMBER

THIS DRAWING IS A CONTROLLED DOCUMENT.		DWN: TIM XUE 21NOV2011	TE Connectivity	
DIMENSIONS:		CHK: ALEX CAI 21NOV2011		
mm	0 PLC ±	APVD: ALEX CAI 21NOV2011	NAME: PT CONNECTOR ASSEMBLY, 20 POS, RIGHT ANGLE, 0.8mm PITCH, SFP+	
	1 PLC ±0.10	PRODUCT SPEC: 108-2331	SIZE: CAGE CODE DRAWING NO: A100779C=2170184	
	2 PLC ±	APPLICATION SPEC: 114-13120	RESTRICTED TO: -	
	3 PLC ±	WEIGHT: -	SCALE: 12:1 SHEET 1 OF 3 REV: A1	
	4 PLC ±	CUSTOMER DRAWING		
	ANGLES ±			
	FINISH: △			

LOC		DIST		REVISIONS			
ES	00	P	LTN	DESCRIPTION	DATE	DWN	APVD
		-		SEE SHEET 1			

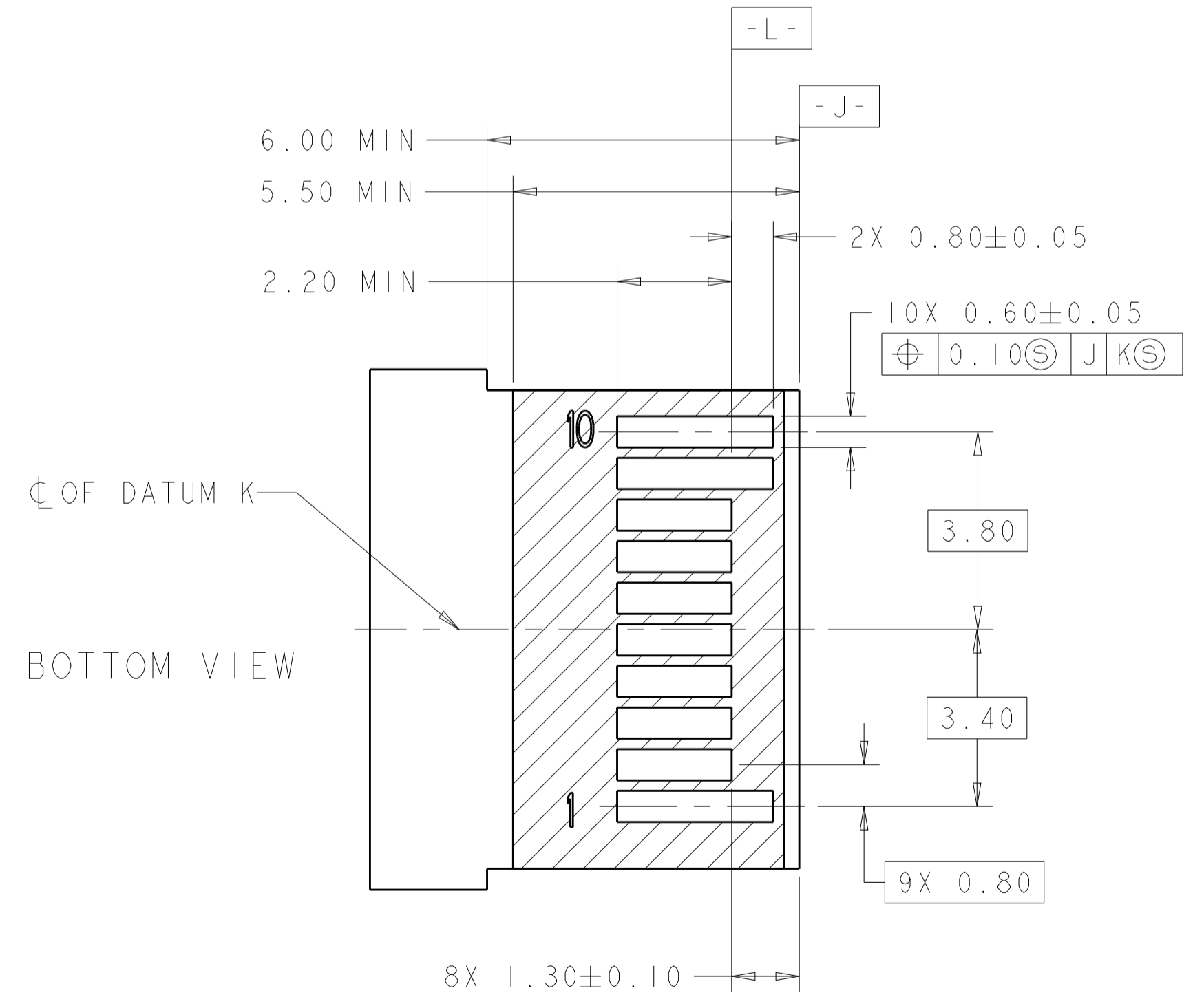
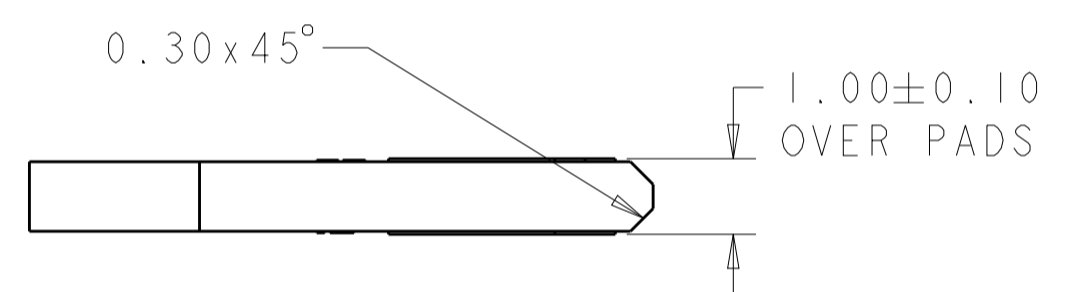
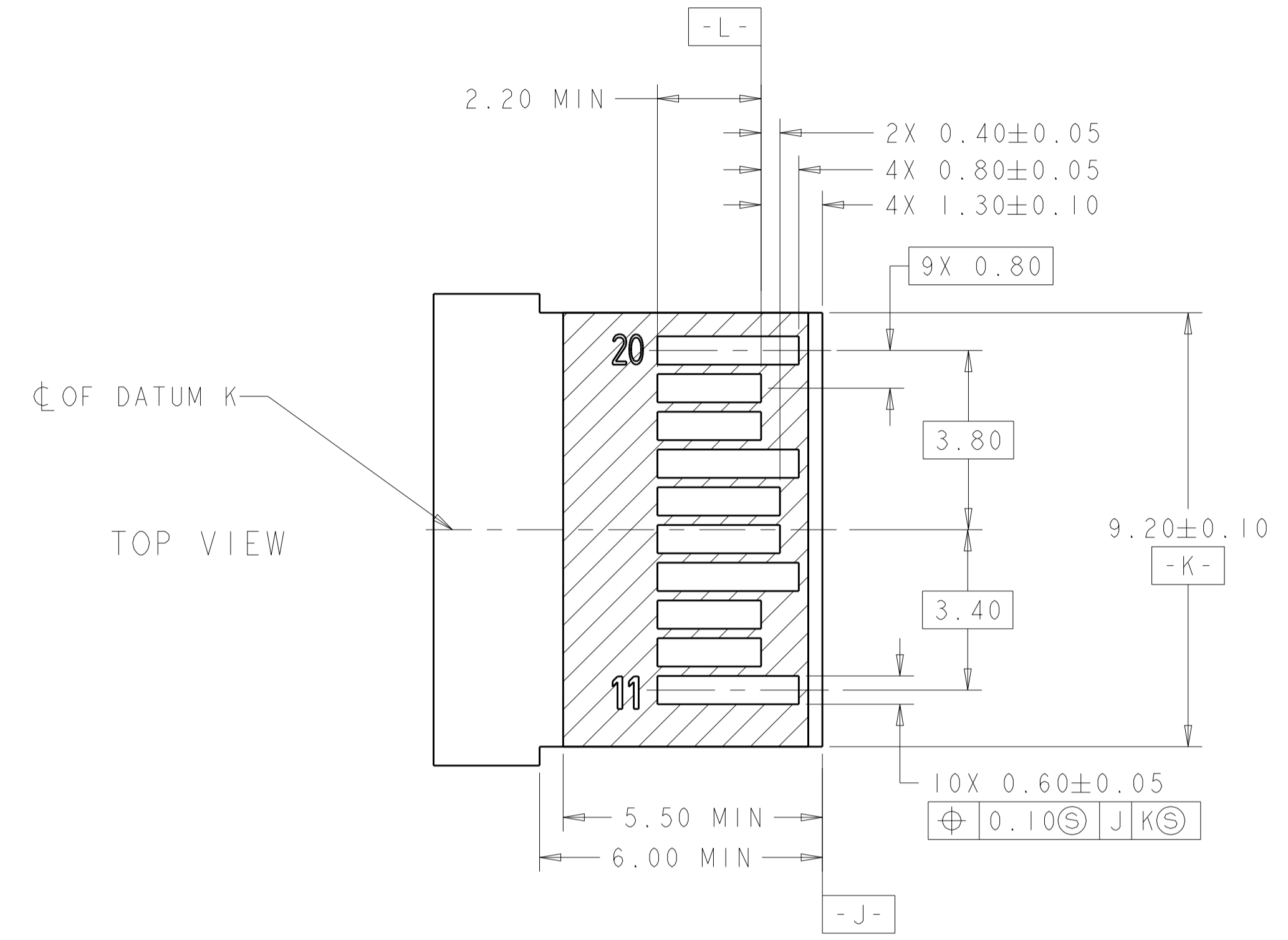

RECOMMENDED LAYOUT DETAIL
 MATING TRANSCEIVER PCB
 SCALE 10:1

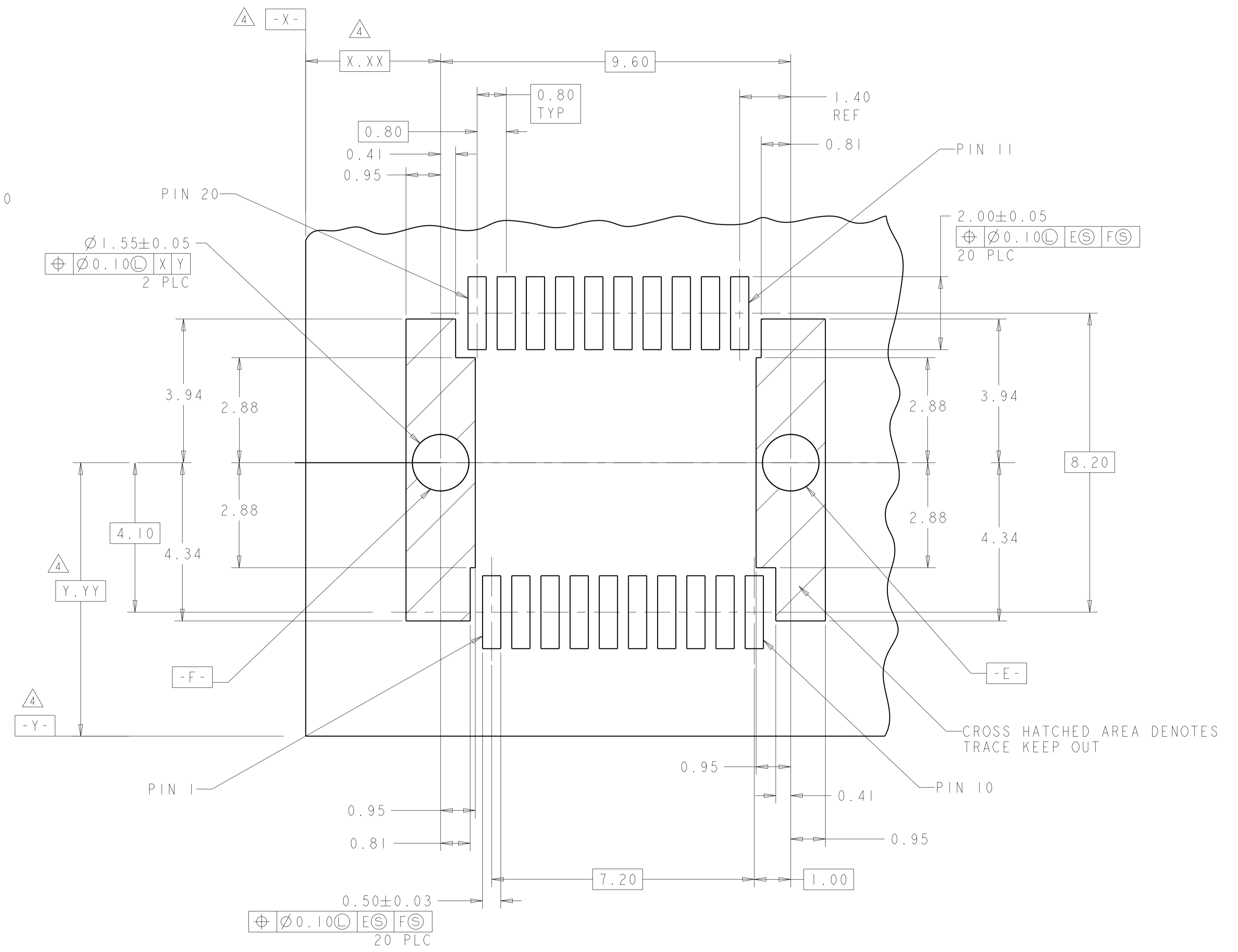

RECOMMENDED PCB LAYOUT DETAIL
 CONNCTOR MOUNTING SIDE
 SCALE 14:1

THIS DRAWING IS A CONTROLLED DOCUMENT.		DWN: TIM XUE 21NOV2011	TE Connectivity
DIMENSIONS: mm		CHK: ALEX CAI 21NOV2011	
TOLERANCES UNLESS OTHERWISE SPECIFIED:		APVD: ALEX CAI 21NOV2011	NAME: PT CONNECTOR ASSEMBLY, 20 POS, RIGHT ANGLE, 0.8mm PITCH, SFP+
0 PLC ±	1 PLC ±0.10	PRODUCT SPEC: 108-2331	SIZE: A1
2 PLC ±	3 PLC ±	APPLICATION SPEC: 114-13120	CAGE CODE: 2170184
4 PLC ±	ANGLES ±	WEIGHT: -	RESTRICTED TO: -
MATERIAL: -	FINISH: -	CUSTOMER DRAWING	SCALE: 12:1 SHEET 2 OF 3 REV: A1

LOC	DIST	REV	DATE	BY	APPV
ES	00				

REVISIONS					
REV	DATE	BY	APPV	DESCRIPTION	DATE
-	-	-	-	SEE SHEET 1	-

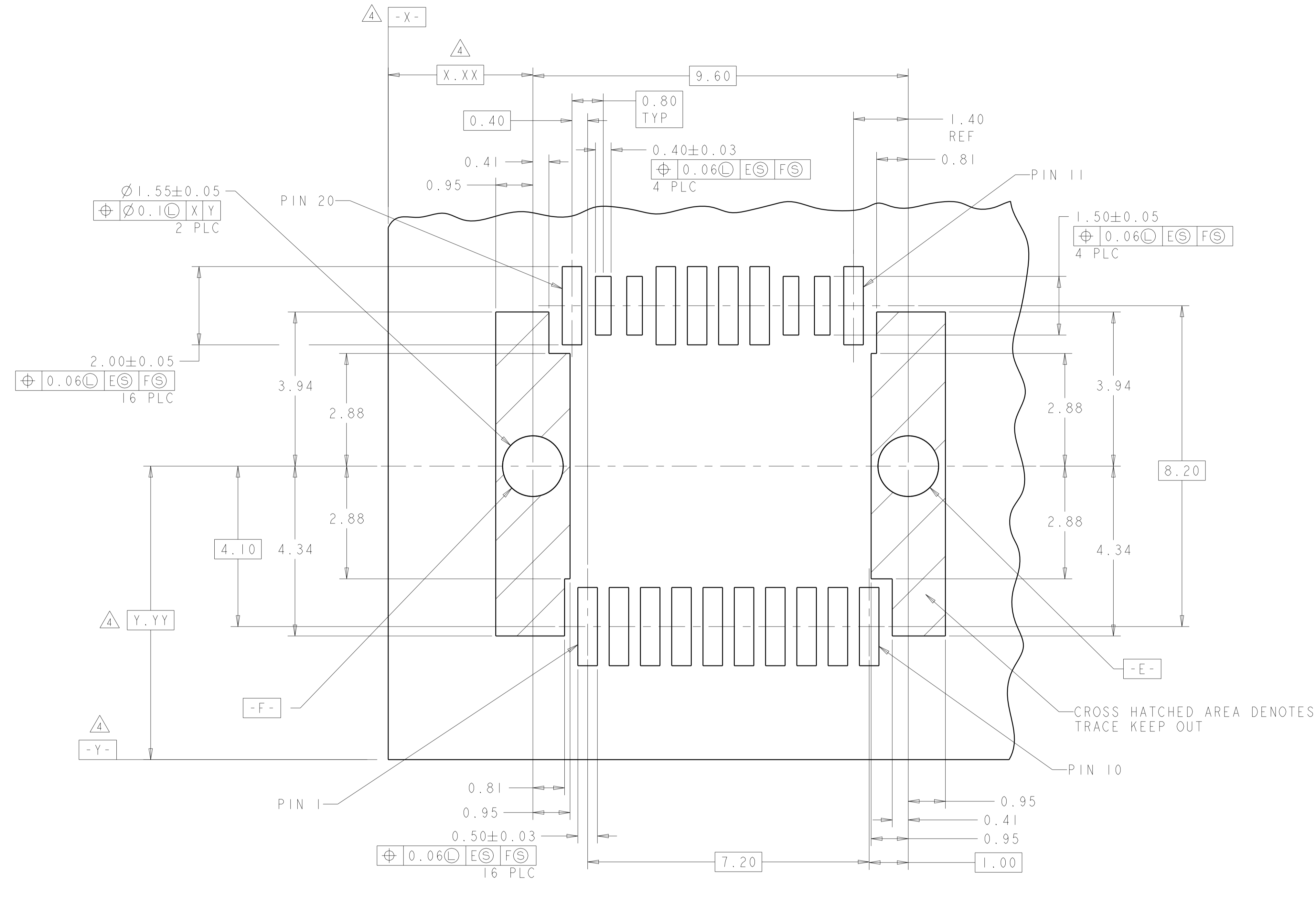

OPTIONAL LAYOUT FOR IMPROVED
 SIGNAL INTEGRITY, MOUNTING SIDE
 SCALE 16:1

THIS DRAWING IS A CONTROLLED DOCUMENT.		OWN: TIM XUE 21NOV2011	TE Connectivity
DIMENSIONS: mm		CHK: ALEX CAI 21NOV2011	
TOLERANCES UNLESS OTHERWISE SPECIFIED:		APVD: ALEX CAI 21NOV2011	NAME: PT CONNECTOR ASSEMBLY, 20 POS, RIGHT ANGLE, 0.8mm PITCH, SFP+
0 PLC ± 1 PLC ± 2 PLC ±0.10 3 PLC ± 4 PLC ± ANGLES ±		PRODUCT SPEC: 108-2331	
MATERIAL: -		APPLICATION SPEC: 114-13120	SIZE: A1
FINISH: -		WEIGHT: -	CAGE CODE: 2170184
CUSTOMER DRAWING		SCALE: 12:1	SHEET 3 OF 3