

# PRODUCT DATA DRAWING

REVISION HISTORY			
REV	DESCRIPTION	DATE	APPROVED
-	NRN 42742	10/18	STW
A	DCN 48217	12/18	STW

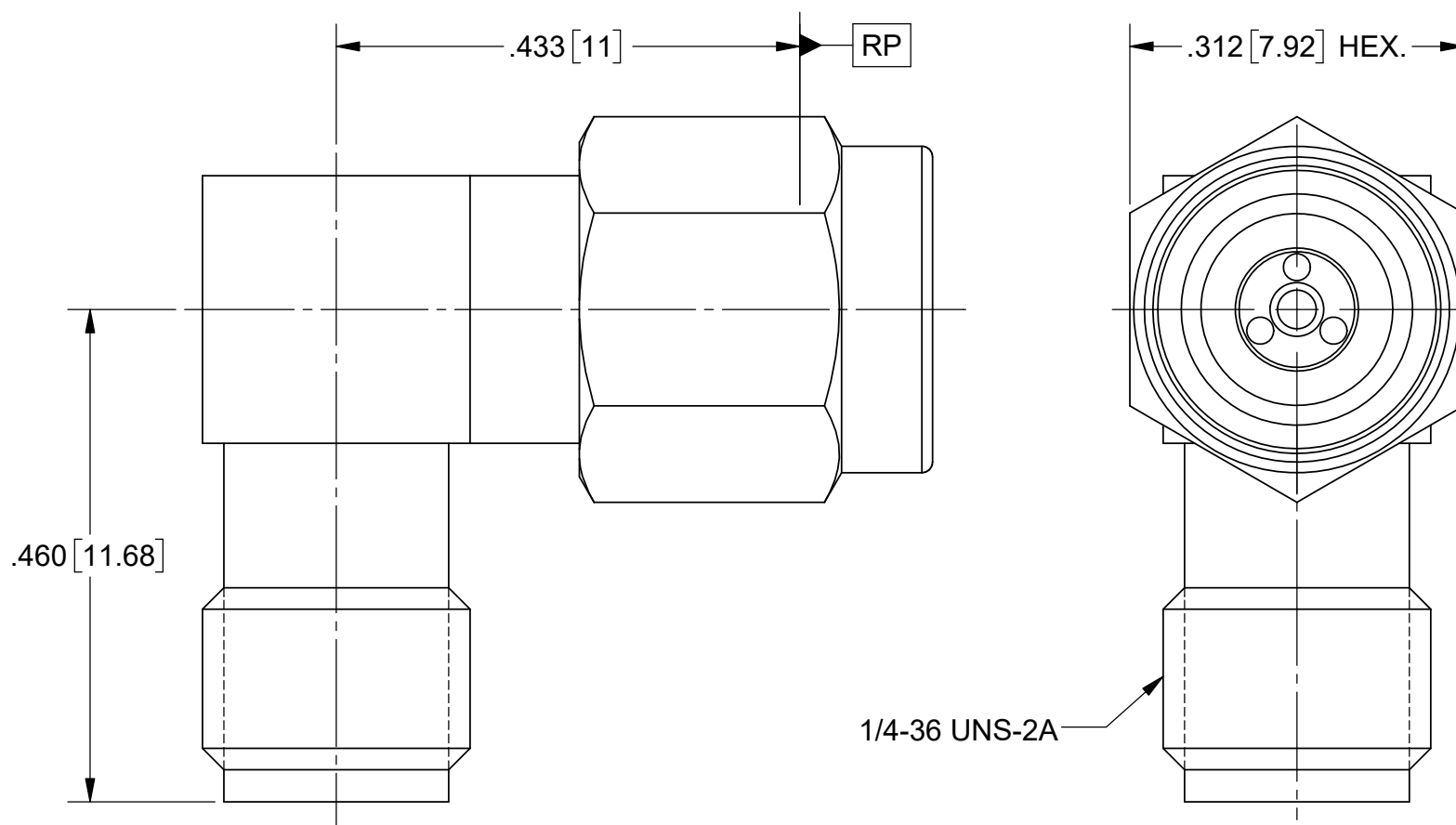

**MATERIAL:**

**BODY, INSERTS & COUPLING NUT:**

STAINLESS STEEL PER AMS-5640, ALLOY UNS S30300, TYPE 1 OR ASTM A582, TYPE 303, CONDITION A.

**CONTACTS:**

BERYLLIUM COPPER PER ASTM B196, ALLOY No. UNS C17300, TD04.

**BEADS:**

PEI (ULTEM 1000) PER ASTM D5205.

**FINISH:**

**BODY, INSERTS & COUPLING NUT:**

PASSIVATED PER AMS 2700.

**CONTACTS:**

GOLD PER MIL-DTL-45204, TYPE I, GRADE C, CLASS 1 OVER NICKEL PER SAE AMS 2404, CLASS 1.

**PERFORMANCE:**

**IMPEDANCE:**  
**FREQ. RANGE:**  
**VSWR:**

50 OHMS  
DC TO 40.0 GHz.  
1.2:1 DC TO 30.0 GHz.  
1.3:1 30.0 GHz TO 40.0 GHz

**DWV:**  
**OPERATING TEMP:**

750 VRMS  
-55°C TO +135°C

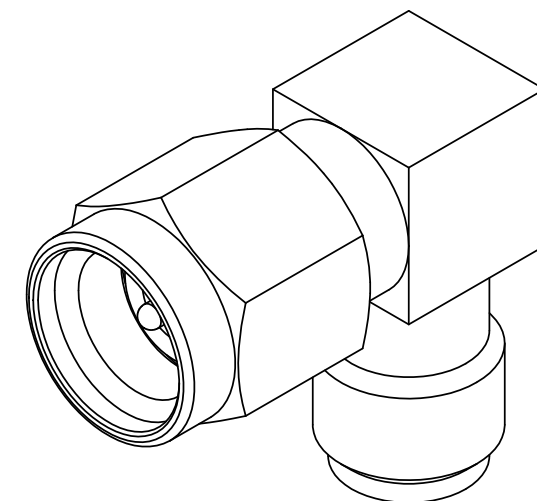

MATERIAL: SEE NOTES	DIMENSIONS ARE IN INCHES TOLERANCES: FRACTIONAL: ±1/64 ANGULAR: X° ±1'0" X°X' ±15'	UNLESS OTHERWISE SPECIFIED 1) ALL DIMENSIONS ARE IN INCHES (MILLIMETERS) 2) ALL DIMENSIONS ARE AFTER PLATING. 3) BREAK CORNERS & EDGES .005 R. MAX. 4) CHAM. 1ST & LAST THREADS. 5) SURFACE ROUGHNESS 63-MIL-STD-10. 6) DIA. 'S ON COMMON CENTERS TO BE CONCENTRIC WITHIN .005 T.I.R. 7) REMOVE ALL BURRS	 2400 Centrepark West Drive, Suite 100 West Palm Beach, FL 33409 TITLE: SVK JACK TO PLUG R/A ADAPTER
FINISH: SEE NOTES	DECIMAL: .X ±.030 .XX ±.010 .XXX ±.005	INTERPRET DIMENSIONS AND TOLERANCES PER ASME Y14.5M - 1994	
SURFACE AREA: N/A	THIRD ANGLE PROJECTION	DRAWN: JPM 10/23/18	SIZE: B CAGE CODE: 95077 DWG. NO.: SF1115-6096
PROPRIETARY THE INFORMATION CONTAINED IN THIS DRAWING IS THE SOLE PROPERTY OF SV MICROWAVE, INC. ANY REPRODUCTION IN PART OR AS A WHOLE WITHOUT THE WRITTEN PERMISSION OF SV MICROWAVE, INC IS PROHIBITED.		CHECKED: STW 10/23/18	SCALE: 6:1
		APPROVED: STW 10/23/18	SHEET 1 OF 1