

PREPARED BY: DATE
A. Yamaguchi *Nov. 12, 1992*

APPROVED BY: DATE
N. Ono *Nov. 12, 1992*

SHARP

ELECTRONIC COMPONENTS GROUP
 SHARP CORPORATION

SPECIFICATION

SPEC No. *ED-92094*

FILE No. *11-11-92*

ISSUE *November 11, 1992*

PAGE 16 Pages

REPRESENTATIVE DIVISION
 PHOTOVOLTAICS DIV.
 OPTO-ELECTRONIC DEVICES DIV.
 ELECTRONIC COMPONENTS DIV.

DEVICE SPECIFICATION FOR

PHOTOINTERRUPTER

MODEL No.

GP2S27T SERIES

Business dealing name

	GP2S27T
	GP2S27T2
	GP2S27T3
	GP2S27T5
	GP2S27T6

1. This specification sheets include the contents under the copyright of Sharp Corporation ("Sharp"). Please keep them with reasonable care as important information. Please don't reproduce or cause anyone reproduce them without Sharp's consent.
2. Please obey the instructions mentioned below for actual use of this device.
 - (1) This device is designed for general electronic equipment. Main uses of this device are as follows;
 - [• Computer · OA equipment · Telecommunication equipment (Terminal)
 - Measuring equipment · Tooling machine · AV equipment
 - Home appliance, etc.]
 - (2) Please take proper steps in order to maintain reliability and safety, in case this device is used for the uses mentioned below which require high reliability.
 - [• Unit concerning control and safety of a vehicle (air plane, train, automobile etc.) · Gas leak detection breaker · Traffic signal
 - Fire box and burglar alarm box · Other safety equipment, etc.]
 - (3) Please don't use for the uses mentioned below which require extremely high reliability
 - [• Space equipment · Telecommunication equipment (Trunk)
 - Nuclear control equipment · Medical equipment (relating to any fatal element), etc.]

CUSTOMER'S APPROVAL

DATE _____

BY _____

PRESENTED BY

K. Ebina

K. Ebina
 Department General Manager of
 Engineering Dept., II
 Opto-Electronic Devices Div.
 ELECOM Group
 SHARP CORPORATION

REFERENCE



1. Application

This specification applies to the outline and characteristics of reflective type photointerrupter, Model No. GP2S27T series.

2. Outline

Refer to the attached drawing No. CY4607i02.

3. Ratings and characteristics

3.1 Absolute maximum ratings

Ta=25°C

Parameter		Symbol	Rating	Unit
Input	Forward current	I_F	50	mA
	Reverse voltage	V_R	6	V
	Power dissipation	P_D	75	mW
Output	Collector-emitter voltage	V_{CEO}	35	V
	Emitter-collector voltage	V_{ECO}	6	V
	Collector current	I_c	20	mA
	Collector power dissipation	P_c	75	mW
Total power dissipation		P_{tot}	100	mW
Operating temperature		T_{opr}	-25 ~ +85	°C
Storage temperature		T_{stg}	-40 ~ +100	°C

REFERENCE

SHARP

3.2 Electro-optical characteristics

Ta=25°C

Parameter		Symbol	MIN.	TYP.	MAX.	Unit	Conditions
Input	Forward voltage	V_F	-	1.2	1.4	V	$I_F=20\text{mA}$
	Reverse current	I_R	-	-	10	μA	$V_R=6\text{V}$
Output	Collector dark current	I_{CEO}	-	1	100	nA	$V_{CE}=20\text{V}$
Transfer characteristics	*1 Collector current	I_c	20	45	120	μA	$V_{CE}=2\text{V}, I_F=4\text{mA}$
	*2 Leak current	I_{LEAK}	-	-	100	nA	$V_{CE}=2\text{V}, I_F=4\text{mA}$
	*3 Response time	(Rise)	t_r	-	20	100	μs
(Fall)		t_f	-	20	100	μs	$R_L=1000\Omega, d=1\text{mm}$

*1 The conditions and arrangement of the reflective object are shown below.

In regard to collector current (I_c), the following ranking shall be carried out.

Rank	Collector current $I_c(\mu\text{A})$
A	20 ~ 42
B	34 ~ 71
C	58 ~ 120

*2 Without reflective object

*3 d: Glass thickness of reflective mirror

(Test circuit for response time)

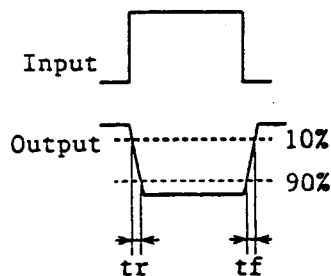
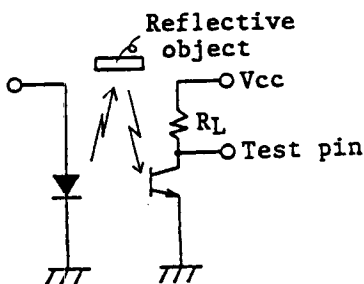

(Test arrangement for collector current)

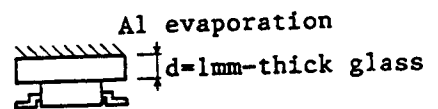

REFERENCE

SHARP

4. Reliability

Refer to the attached sheet, Page 7, 8.

5. Incoming inspection

Refer to the attached sheet, Page 9.

6. Supplements

6.1 Device delivery shall be delivered model that has "○" marking in the rank table below. However, in case delivered model has 2 ranks or more, the quantity of each rank shall be not prescribed.

Collector current (Ic) rank table

Rank at delivery	Model No.	Ic (μA)	Rank
	GP2S27T	20 ~ 120	A, B or C
	GP2S27T2	34 ~ 71	B
	GP2S27T3	58 ~ 120	C
	GP2S27T5	20 ~ 71	A or B
	GP2S27T6	34 ~ 120	B or C

Test conditions
V _{CE} =2V
I _F =4mA
T _a =25°C

6.2 Parts

Refer to the attached sheet, Page 10.

REFERENCE**7. Notes**

- 1) In circuit designing, make allowance for the degradation of the light emitting diode output that results from long continuous operation. (MAX.: 50% degradation/5 years)
- 2) To prevent photointerrupter from faulty operation caused by external light, do not set the detecting surface face to the external light.
- 3) The distance between the photointerrupter and the object to be detected shall be determined the distance by referencing attached graph "Relative collector current vs. distance".

4) Soldering

- (1) Solder reflow

Please do only one soldering at the temperature and the time within the temperature profile in page 12.

- (2) Soldering by hand

To solder onto lead pins, please solder at 260°C for 3 seconds or less. And please take care not to let any external force exert on lead pins when soldering.

- 5) Cleaning shall carry out as the below items to avoid keeping solvent, solder and flux on the device.

- (1) Solvent cleaning: Solvent temperature 45°C or less
Immersion 3 min. or less
- (2) Ultrasonic cleaning: Please don't carry out ultrasonic cleaning.
- (3) The cleaning shall be carried out with solvent below.

Solvent: Ethyl alcohol, Methyl alcohol, Freon TE·TF
Daiflon-solvent S3-E

- (4) Please refrain from using Chloro Fluoro Carbon type solvent to clean devices as much as possible since it is internationally restricted to protect the ozoneosphere. Before you use alternative solvent you are requested to confirm that it does not damage package resin.

8. Others

Any doubt as to this specification shall be determined in good faith upon mutual consultation of the both parties.

2. Outline Dimensions (Drawing No. CY4607i02)

Scale : 10/1 Unit : 1/1mm

REFERENCE

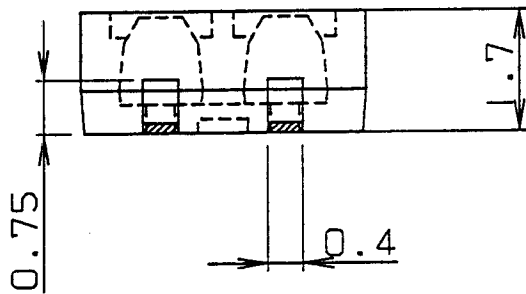
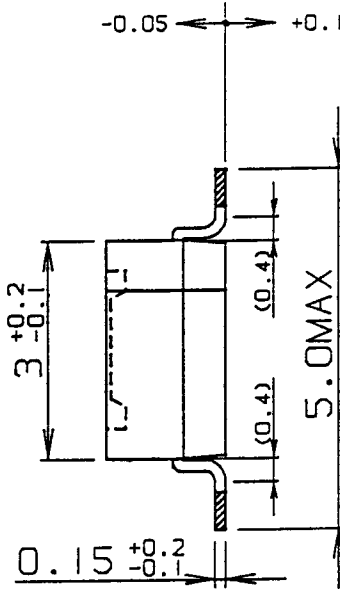
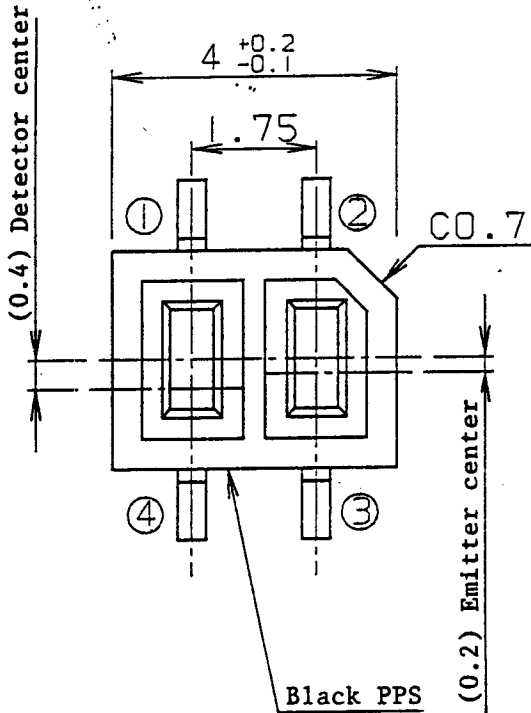

- 1) Unspecified tolerance shall be ± 0.15 .
- 2) Dimensions in parenthesis are shown for reference.
- 3) Parallel balance of 4 lead pins shall be within ± 0.15 .
- 4) The dimensions shown do not include those of burrs. Burr's dimensions shall be 0.15 MAX .
- 5) Internal connection diagram is shown below.

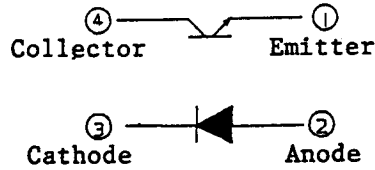

- 6) Marked face shall be surface A. The symbols of rank mark and production month is as follows.

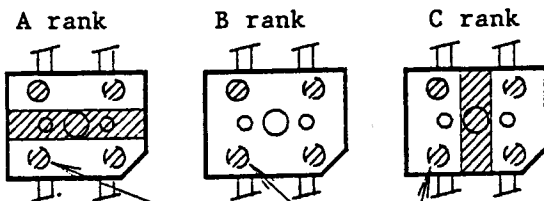

Product month symbol

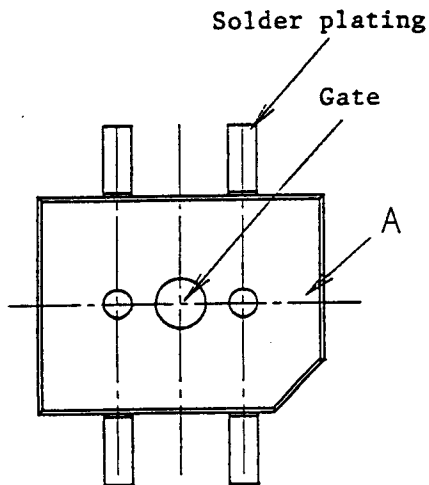

- 7) The oblique portions are no solder plating area.

REFERENCE

Power dissipation vs. ambient temperature

Power dissipation P_D , P_C , P_{tot} (mW)

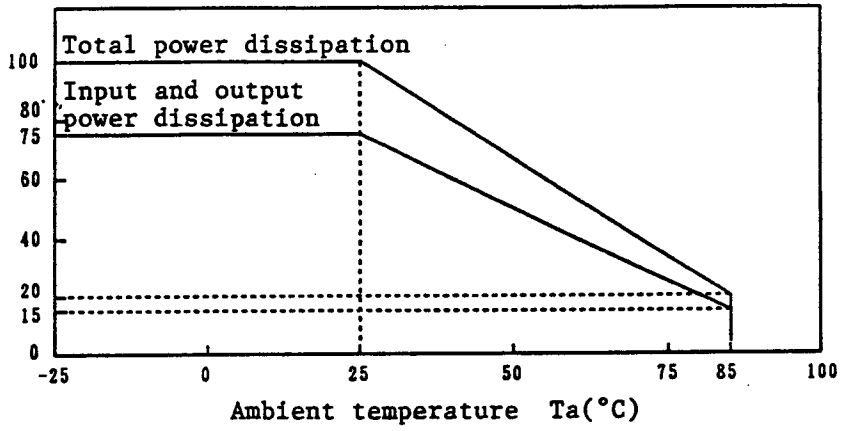

Relative collector current vs. distance (reference)

Relative collector current (%)

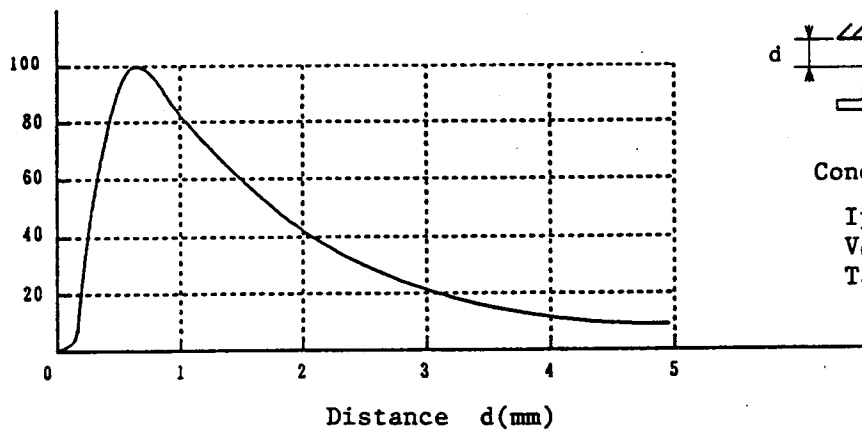

Al evaporation surface

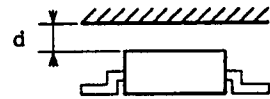

Conditions

$I_F=4mA$
 $V_{CE}=2V$
 $T_a=25^\circ C$

SHARP

4. Reliability

The reliability of products shall be satisfied with items listed below.

Confidence level : 90%
LTPD : 10%/20%

Test Items	Test Conditions	Failure Judgement Criteria	Samples (n)	
			Defective(c)	
Temperature cycling	1 cycle -40°C ~ +100°C (30min.) (30min.) 20 cycle test	$V_F \geq U \times 1.2$ $I_c \leq L \times 0.8$ $I_{LEAK} \geq U \times 2$ $I_R \geq U \times 2$ $I_{CEO} \geq U \times 2$ U: Upper specification limit L: Lower specification limit	n=22, c=0	
Humidity storage	+60°C, 90%RH, 500h		n=22, c=0	
High temp. storage	+100°C, 500h		n=22, c=0	
Low temp. storage	-40°C, 500h		n=22, c=0	
Operation life	$I_F=50mA$, $T_a=25^\circ C$, 500h $P_{tot}=100mW$		n=22, c=0	
Mechanical shock	$15000m/s^2$ {1500G}, 0.5ms, 3 times/ $\pm X$, $\pm Y$, $\pm Z$ direction		n=11, c=0	
Variable frequency vibration	100 ~ 2000 ~ 100 Hz/20min. 2h/ X, Y, Z direction $100m/s^2$ {10G}		n=11, c=0	
Terminal strength (Tension)	Weight: 3N{0.3kgf} 30 s/each terminal		n=11, c=0	
Terminal strength (Bending)	Weight: 1N{0.1kgf} $0^\circ \rightarrow 90^\circ \rightarrow 0^\circ$ 2 times bending		n=11, c=0	
Soldering heat	260°C, 3s Immerse up to 0.5mm from the bottom face of package.		n=11, c=0	
Solderability	230°C, 3 s Prior disposition: Dip rogin flux. Then immerse up to 0.5mm from the bottom face of package.		Judgement only appearance Solder shall adhere at the aera of 95% or more of dipped portion	n=11, c=0

For details, conforms to JIS C 7021.

SHARP

REFERENCE

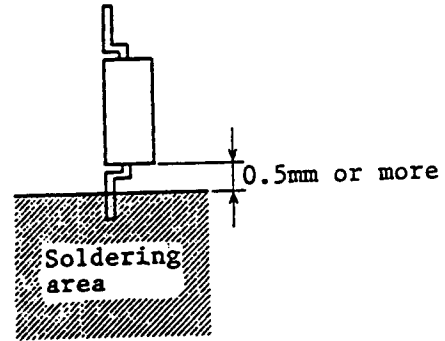
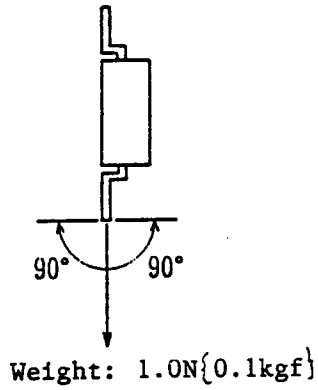

4.1 Solder reflow

Confidence level : 90%
LTPD : 10% / 20%

Test Item	Test condition	Failure Judgement Criteria	Samples (n) Defective(c)
Solder reflow	Refer to the attached sheet, Page 12. 1 time	$I_c < L \times 0.8$	n=22, c=0

SHARP

REFERENCE

5. Incoming inspection

5.1 Inspection items

(1) Electrical characteristics

V_F , I_R , BV_{ECO} , BV_{CEO} , I_c , I_{CEO}

(2) Appearance

5.2 Sampling method and Inspection level

A single sampling plan, normal inspection level II based on MIL-STD-105D is applied. The AQL according to the inspection items are shown below.

Defect	Inspection item	AQL(%)
Major defect	Characteristics defect	0.1
	Unreadable marking	
Minor defect	Appearance defect except the above mentioned. *	0.4

* Crack Visible crack shall be defect.

Split
 * Chip One which affects the electrical characteristics shall be defect.
 Scratch
 The others

* Void One which is void across central separator on photo sensor shall be defect.

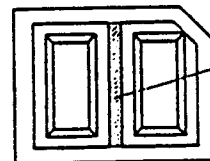

Central separator

The other place voids, one which affects the electrical characteristics shall be defect.

SHARP**REFERENCE**

6. Supplements

6.1 Parts

This product uses the below parts.

6.1.1 Light detector

Type	Material	Maximum sensitivity wavelength (nm)	Sensitivity wavelength (nm)	Response time (μ s)
Phototransistor	Silicon (Si)	800	700 ~ 1200	20

6.1.2 Light emitter

Type	Material	Maximum light emitting wavelength (nm)	I/O Frequency (MHz)
Infrared light emitting diode (non-coherent)	GaAs	950	0.3

6.1.3 Material

Case	Lead frame	Lead frame plating
Black PPS resin	42 Alloy	Solder plating

6.1.4 Others

This product shall not be proof against radiation flux.

Precautions for Soldering photointerrupter

1. In case, solder reflow

Please do only one soldering at the temperature and the time within the temperature profile as shown in the figure.

REFERENCE

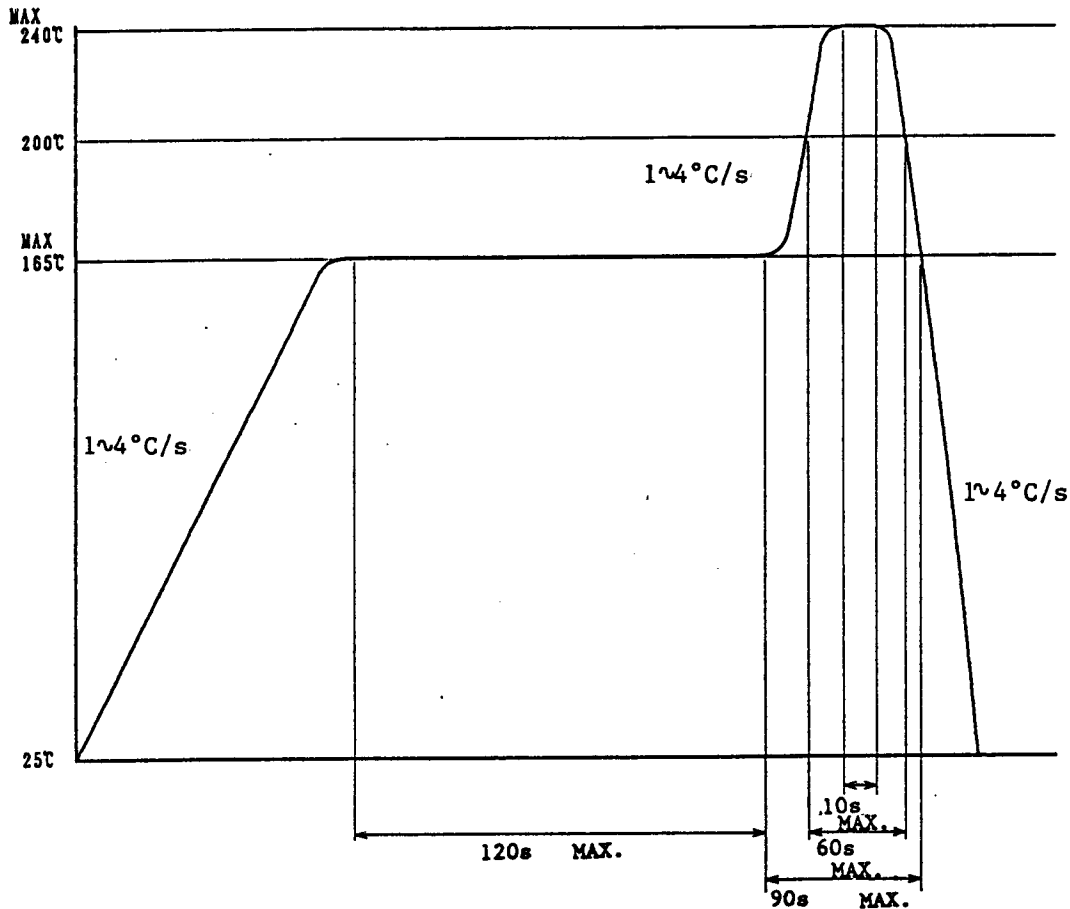

2. Other precautions

An infrared lamp used to heat up for soldering may cause a localized temperature rise in the resin. So keep the package temperature within that specified in Item 1. Also avoid immersing the resin part in the solder. Even if within the temperature profile above, there is the possibility that the gold wire in package is broken in case that the deformation of PWB gives the affection to lead pins. Please use after confirmation the conditions fully by actual solder reflow machine.

SHARP

REFERENCE

Package specifications (ϕ 178mm reel)

1. Application

This specification applies to the taping specifications and the relation items for the GP2S27T series.

2. Taping method

(2.1) Tape structure and Dimensions (Refer to the attached sheet-2-2)

The tape shall have a structure in which a cover tape is sealed heat-pressed on the carrier tape of hard vinyl-chloride to protect against static electricity.

(2.2) Reel structure and Dimensions (Refer to the attached sheet-2-3)

The taping reel shall be corrugated cardboard-made with its dimensions as shown in the attached drawing.

(2.3) Direction of product insertion (Refer to the attached sheet-2-3)

Product direction in carrier tape shall direct to the anode mark at the hole side on the tape.

3. Adhesiveness of cover tape

The exfoliation force between carrier tape and cover tape shall be $0.2N\{0.02kgf\}$ to $1N\{0.1kgf\}$ for the angle from 160° to 180° .

4. Rolling method and quantity

Wind the tape back on the reel so that the cover tape will be outside the tape. Attach more than 20cm of blank tape to the trailer and the leader of the tape and fix the both ends with adhesive tape. One reel shall contain 1000 pcs.

5. Marking

The outer packaging case shall be marked with following information.

* Model No. * Number of pieces delivered * Production date

6. Safety protection during shipping

There shall be no deformation of component or degradation of electrical characteristics due to shipping.

Tape structure and Dimensions

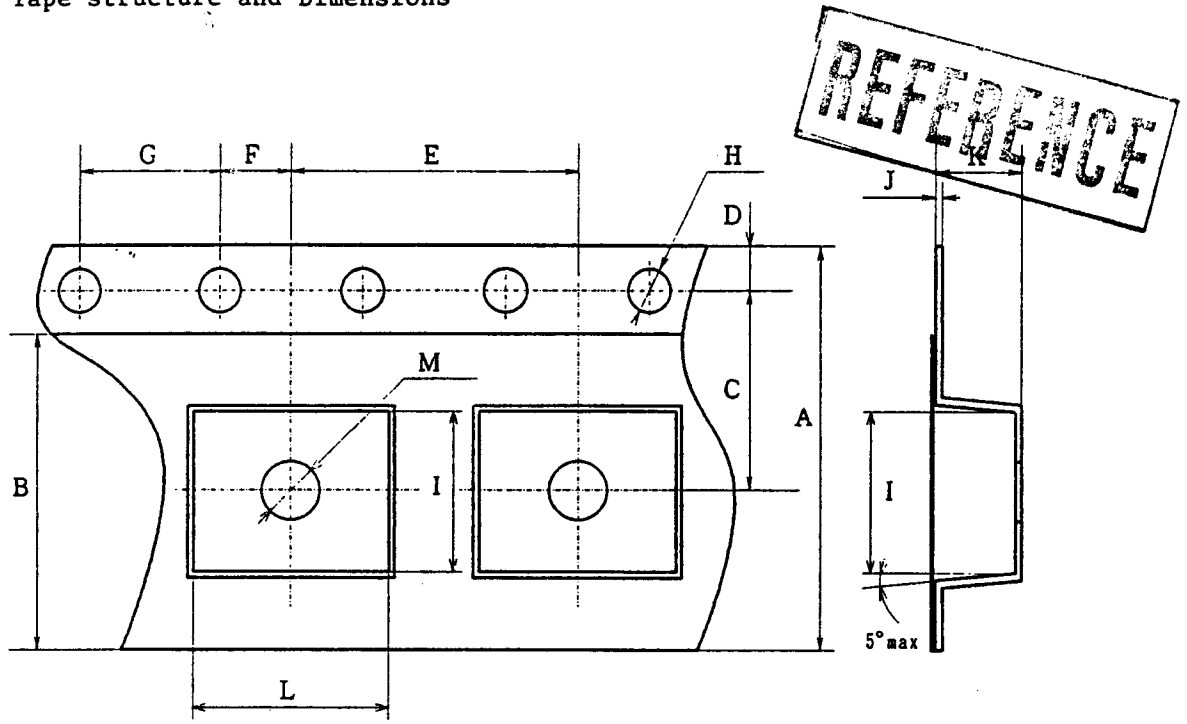

Symbol	A	B	C	D	E	F
Unit						
mm	12.0 ±0.3	7.6 ±0.3 / 0.0	5.5 ±0.05	1.75 ±0.1	8.0 ±0.1	2.0 ±0.05

Symbol	G	H	I	J	K	L	M
Unit							
mm	4.0 ±0.1	φ1.5 ±0.1 / 0.0	4.4 ±0.1	0.3 ±0.05	2.0 ±0.1	5.2 ±0.1	φ1.6 ±0.1 / 0

Reel structure and Dimensions

REFERENCE

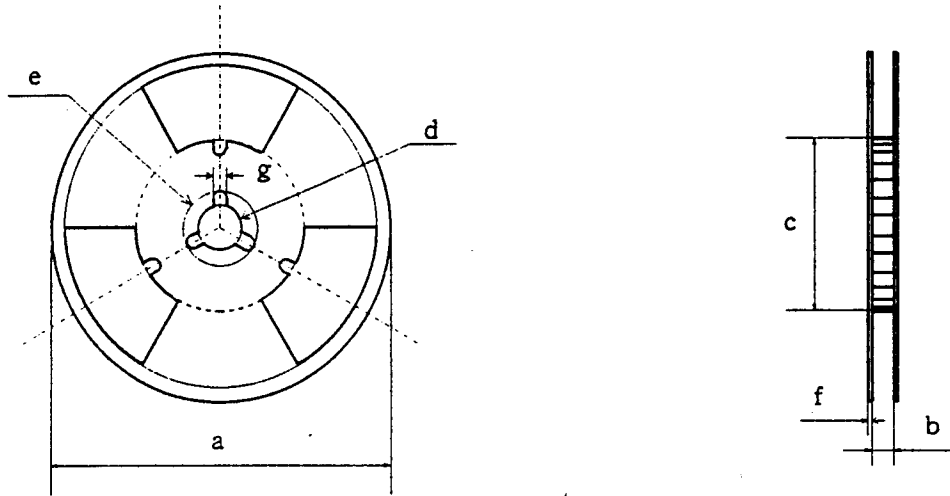

Symbol	Check word						
Unit	a	b	c	d	e	f	g
mm	178	13.5±1	80±0.1	13±0.5	23±1	2.0±0.5	2.5±0.5

Direction of product insertion

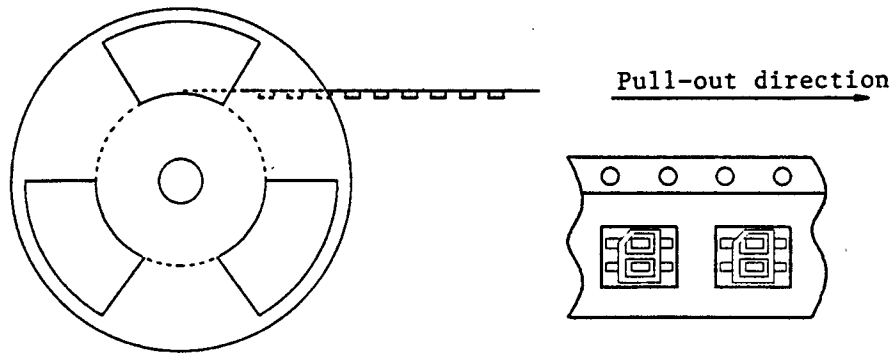

SHARP

Moisture-proof package specification (ϕ 178mm reel)

REFERENCE

1. Application

This specification applies to the products which Sharp delivers to customer.

2. Packaging specifications

2.1 Packaging material

Name	Material	Q'ty	Aim
Aluminium laminated sack	Aluminium polyethylene	Refer to 2.2	Moisture-proof
Label	Paper(-made)	-	Indication of Model No. and Q'ty

2.2 Packaging method

- (1) Seal the aluminium laminated sack included the ruled tape-reel quantity.
- (2) Fill up the blank of label and paste on the sack.
- (3) Put the moisture-proof laminated sack in the ruled case.

Packaging shape	Product	Q'ty	Moisture-proof sack Q'ty
Tape-reel(ϕ 178mm)	1ch. type	1000 pcs./reel	1reel/sack

Minimum order Q'ty : 1 reel/sack

3. Storage and management after open

3.1 Storage condition : Storage shall be in accordance with the below conditions.

Storage temp. : 5 to 30°C

Storage humidity : 70%RH or less

SHARP**REFERENCE**

3.2 Treatment after open

- (1) After open, please mount at the conditions of humidity 60%RH or less and temperature 5 to 25°C within 2 days.
- (2) In case of long time storage after open, please mount at the conditions of humidity 70%RH or less and temperature 5 to 30°C within 2 weeks by using dry box or resealing with desiccant in moisture-proof sack by sealer.

3.3 Baking before mounting

In case that it could not carry out the above treatment, it is able to mount by baking treatment. However baking treatment shall be limited only 1 time.

Recommended conditions : 125°C, 16 to 24 hours

- * Baking treatment can not carry out at the packaged condition. please carry out baking at the condition of mounting on PWB or getting on the metal tray.

SPECIFICATIONS ARE SUBJECT TO CHANGE WITHOUT NOTICE.

Suggested applications (if any) are for standard use; See Important Restrictions for limitations on special applications. See Limited Warranty for SHARP's product warranty. The Limited Warranty is in lieu, and exclusive of, all other warranties, express or implied. ALL EXPRESS AND IMPLIED WARRANTIES, INCLUDING THE WARRANTIES OF MERCHANTABILITY, FITNESS FOR USE AND FITNESS FOR A PARTICULAR PURPOSE, ARE SPECIFICALLY EXCLUDED. In no event will SHARP be liable, or in any way responsible, for any incidental or consequential economic or property damage.

SHARP®

NORTH AMERICA

SHARP Microelectronics
of the Americas
5700 NW Pacific Rim Blvd.
Camas, WA 98607, U.S.A.
Phone: (360) 834-2500
Fax: (360) 834-8903
<http://www.sharpsma.com>

EUROPE

SHARP Microelectronics Europe
Sonninstraße 3
20097 Hamburg, Germany
Phone: (49) 40 2376-2286
Fax: (49) 40 2376-2232
<http://www.sharpsme.com>

ASIA

SHARP Corporation
Integrated Circuits Group
2613-1 Ichinomoto-Cho
Tenri-City, Nara, 632, Japan
Phone: +81-743-65-1321
Fax: +81-743-65-1532
<http://www.sharp.co.jp>