



TCNM-ACBB1 Installation Manual

The TCNM-ACBB1 is a connection box that can be used as an accessory to facilitate system connections for installation and device replacement of several Banner family reading devices.

System cabling is made through spring clamp terminal blocks inside the TCNM-ACBB1 while the reading device is connected to the TCNM-ACBB1 through a 25 pin connector on the housing.

A 9-pin connector placed inside the TCNM-ACBB1 facilitates connection between an external PC and the auxiliary serial interface of the reading device for configuration or data monitoring.

TCNM-ACBB1 can also house an accessory Backup and Restore Module to make system maintenance extremely quick and easy.

General View

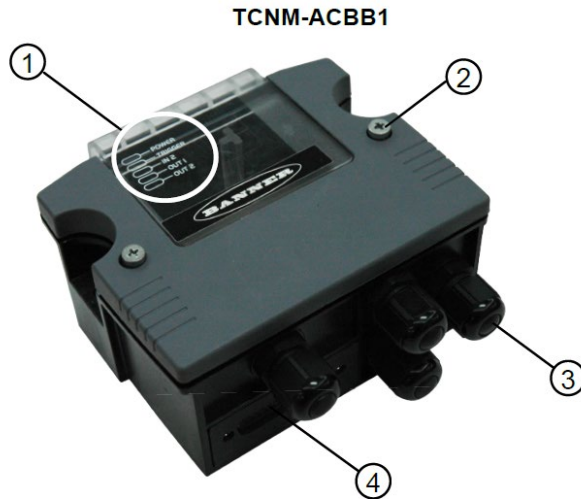

- 1 – Indicator LEDs
- 2 – Cover screws (2)
- 3 – Compression connectors (4)
- 4 – 25-pin device connector

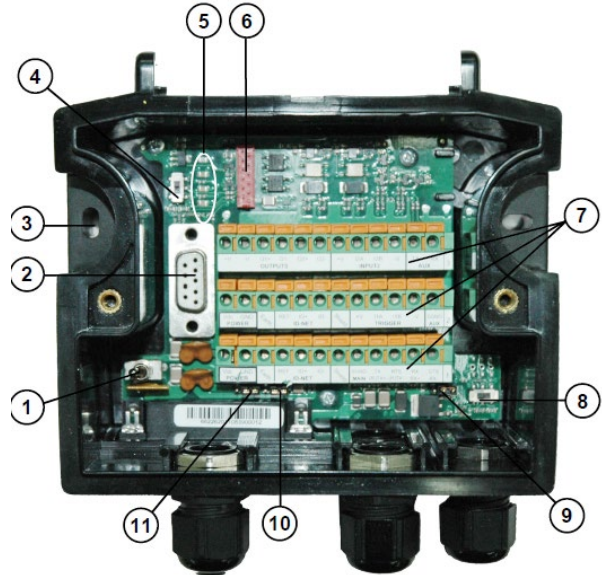

- 1 – Power switch (on/off)
- 2 – Auxiliary port connector
- 3 – Mounting holes (2)
- 4 – ID-NET termination resistance switch
- 5 – Indicator LEDs
- 6 – Backup module connector
- 7 – Spring clamp terminal blocks
- 8 – RS485 termination resistance switch
- 9 – Power source selector
- 10 – Shield to protection earth selector
- 11 – Chassis grounding selector

Safety Precautions

ATTENTION: READ THIS INFORMATION BEFORE INSTALLING THE PRODUCT POWER SUPPLY

This product is intended to be installed by Qualified Personnel only. This device is intended to be supplied by a UL Listed NEC Class 2 power source.



Total power consumption is given by adding the TCNM-ACBB1 power consumption to that of all the devices powered through the TCNM-ACBB1 (reading device, P.S.,I/O). Refer to the manual of the connected devices for details about minimum/maximum supply voltage and power consumption.

Each TCNM-ACBB1 supports only 1 single reading device + system accessories.

Compatible Reading Device Models

The TCNM-ACBB1 can be connected to the following readers using the 25-pin connector.

- ABR 3000
- ABR 7000
- TCNM-AD
- TCNM-EX
- TXHNM-SP

Opening the TCNM-ACBB1

To install the TCNM-ACBB1 or during normal maintenance, it is necessary to open it by unscrewing the two cover screws.



Disconnect the TCNM-ACBB1 from the power supply during this operation.

Mechanical Installation

TCNM-ACBB1 can be mounted to various wooden or plastic surfaces using the two self-threading screws (3.9 x 45 mm) and washers provided in the package.

Mounting to other surfaces, such as concrete walls or metallic panels, requires user-supplied parts (screws, screw anchors, nuts, etc). A mounting template is included in the package to facilitate hole drilling alignment.

TCNM-ACBB1 can also be mounted to a DIN rail or a Bosch Frame using the mounting accessories.

The diagram below gives the overall dimensions of the TCNM-ACBB1 and shows the two mounting through-holes.

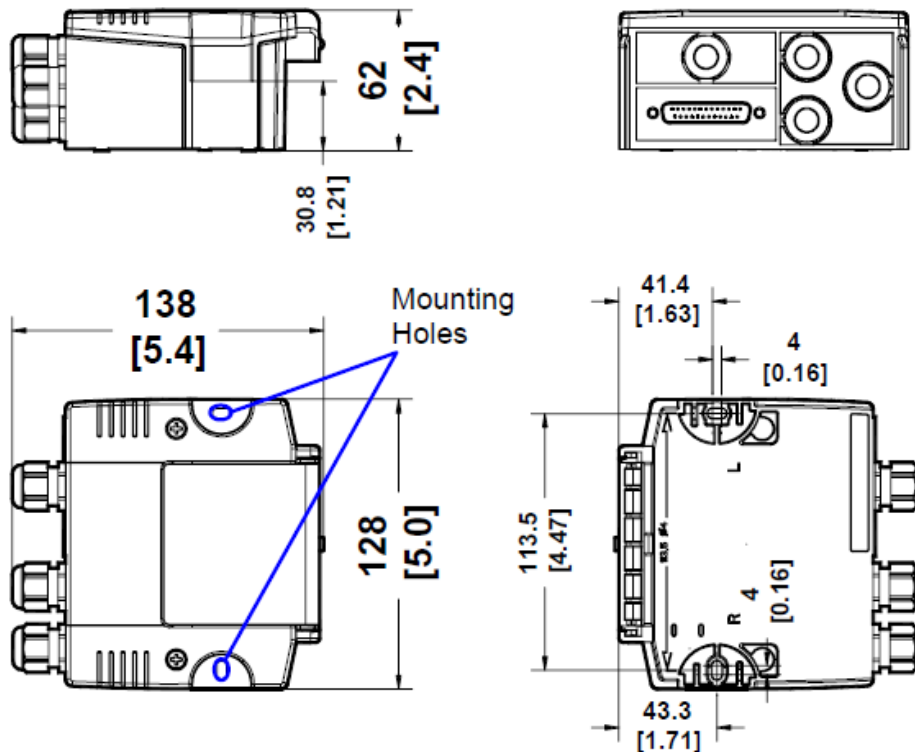

Electrical Connections and Setup

The following figure shows a typical layout.

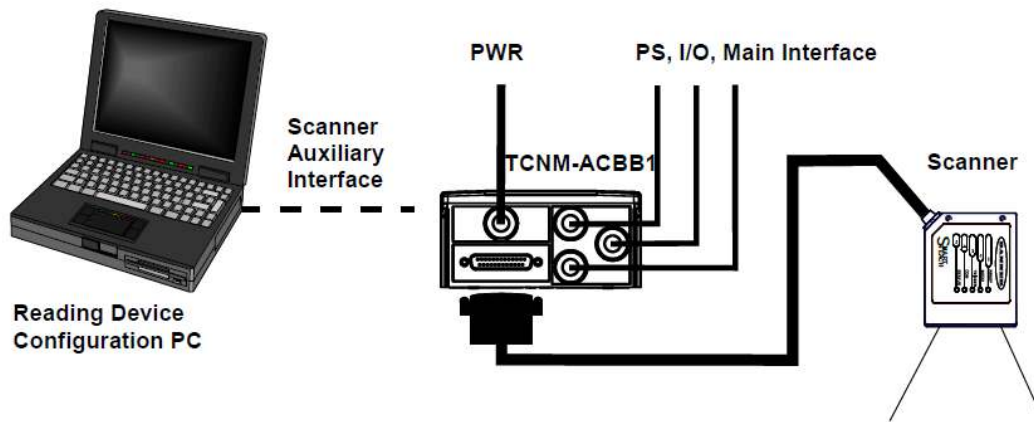

The dotted line in the figure refers to an optional (temporary) hardware configuration in which a portable PC can be quickly connected to the TCNM-ACBB1 (and consequently to the reading device auxiliary interface) through the internal 9-pin connector. This allows monitoring of the data transmitted by the reading device or configuration through the utility program (see the reading device Installation Manual for more details). The reading device auxiliary interface signals are also available on the internal spring clamp connectors.

After making system cabling and switch settings, connect the reading device to the 25-pin connector on the TCNM-ACBB1 housing.

Switch ON the TCNM-ACBB1 power switch. The Power LED turns on (blue) when the power connection has the correct polarity. The Power LED turns on (red) in case of wrong polarity.

After system functioning has been verified, close the TCNM-ACBB1 using the two cover screws.

Power Supply

Power is supplied to the TCNM-ACBB1 through the Vdc and GND pins provided on the spring clamp connector.

The power switch switches the power supply ON or OFF for both the TCNM-ACBB1 and the connected reading device.



The power switch does not control power to the Vdc/GND, +V/-V spring clamps, therefore any devices connected to these signals (i.e. external trigger, encoder, etc.), are live and are not protected from polarity inversion. Disconnect the power supply when working inside the TCNM-ACBB1.

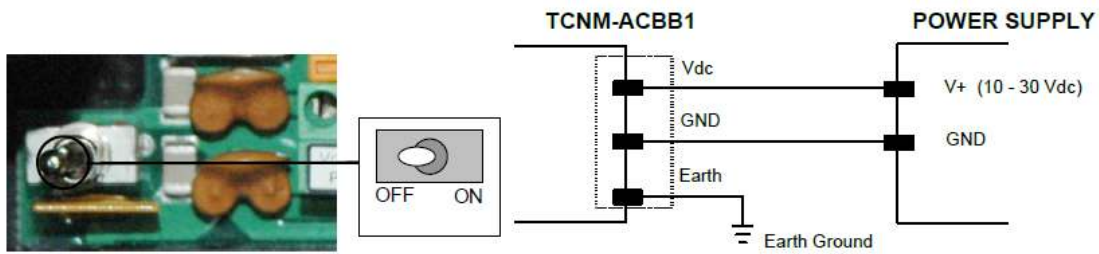

Power Switch ON/OFF Positions and Connections

Vdc is electrically connected to +V, just as GND is electrically connected to -V. This is useful for supplying external trigger, inputs and outputs from the TCNM-A CBB1 power source, however +V and -V signals should not be used as power supply inputs to the TCNM-ACBB1.

The power supply must be between 10 and 30 Vdc only.

To avoid electromagnetic interference:

- *Connect TCNM-ACBB1 Protection Earth (Earth) to a good earth ground.*
- *Connect the reading device chassis to earth ground through the jumper, (default setting).*
- *Connect the Network Cable Shield (Shield) to Filtered Earth through the jumper (default setting).*

System Wiring

The connection and wiring procedure for TCNM-ACBB1 is described as follows:

- 1) Open the TCNM-ACBB1 by unscrewing the two cover screws.
- 2) Verify that the TCNM-ACBB1 power switch is off.
- 3) Unscrew the compression connectors and pass all the system cables through them into the TCNM-ACBB1 housing.
- 4) To connect the power and input/output signals:
 - a. Prepare the individual wires of the system cables by stripping the insulation back approximately 1 cm.
 - b. Using a device such as a screwdriver, push down on the lever directly next to the clamp.
 - c. Insert the wire into the clamp and release the lever.

The wire will now be held in the spring clamp.

- 5) Tighten the compression connector nuts so that the internal glands seal around the cables.

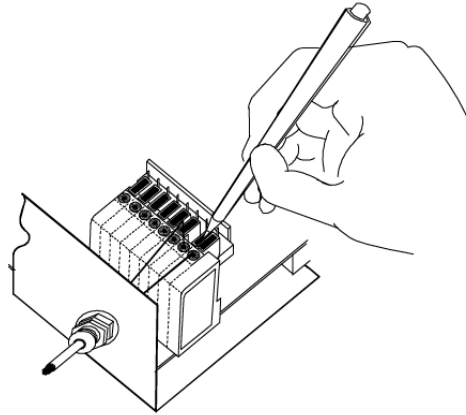

System Cable Connections

Use flexible stranded wire and meet the following specifications.

All positions: 24 - 16 AWG 0.2 - 1.5 mm²

The TCNM-ACBB1 spring clamp connector pinouts are indicated in the pinout table.

Refer to the reading device installation manual for signal details.

Pinouts

Group	Name	Function
Input Power	Vdc	Power Supply Input Voltage +
	GND	Power Supply Input Voltage -
	Earth	Protection Earth Ground
External Trigger Input	V+	Power Source – External Trigger
	I1A	External Trigger A (polarity insensitive)
	I1B	External Trigger B (polarity insensitive)
	-V	Power Reference – External Trigger
Generic Input	+V	Power Source – Inputs
	I2A	Input 2 A (polarity insensitive)
	I2B	Input 2 B (polarity insensitive)
	-V	Power Reference – Inputs
Outputs	+V	Power Source – Outputs
	-V	Power Reference – Outputs
	O1+	Output 1 +
	O1-	Output 1 -
	O2+	Output 2 +
	O2-	Output 2 -
Auxiliary Interface	TX	Auxiliary Interface TX
	RX	Auxiliary Interface RX
	SGND	Auxiliary Interface Reference
ID-NET	REF	Network Reference
	ID+	ID-NET Network +
	ID-	ID-NET Network -
Network	Shield	Network Shield Cable

Main Interface	RS232	RS485FD	RS485HD
	TX	TX+	RTX+
	RTS	TX-	RTX-
	RX	*RX+	
	CTS	*RX-	
	SGND	SGND	SGND

The input power signals Vdc, GND, and Earth as well as the network signals REF, ID+, ID-, and Shield are repeated to facilitate system cabling. In this way, the power and network busses can enter and exit the TCNM-ACBB1 from different spring clamps but be physically connected together.

Power Source Jumper Settings

For most applications, input power is provided through the dedicated spring clamp connectors inside the TCNM-ACBB1. However, TCNM-ACBB1 may accept power from the connected reading device through the 25-pin connector. This is useful, for example, to pass power to connected accessories such as Encoder. See the relative reading device Reference Manual for details.

To power TCNM-ACBB1 from the reading device, place the power source jumper in the "power from device" position as indicated.

Power Source Jumper Settings

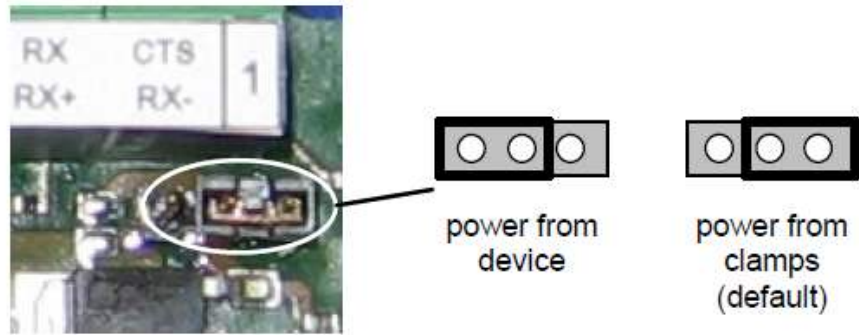

Shield to Protection Earth Jumper Settings

The network cable shield (Shield) can be connected to Earth Ground (Earth) either directly or through a filter circuit. If the jumper is left open, the network cable shield (Shield) is floating.

Shield to Protection Earth Jumper Settings

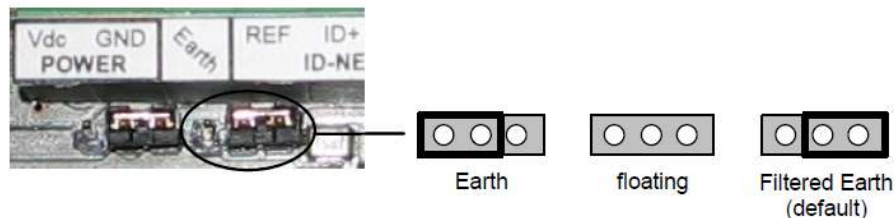

Chassis Grounding Jumper Settings

Select the reading device chassis grounding method by positioning a jumper. In this way the reading device chassis can be connected to earth ground (only if pin Earth is connected to a good earth ground).

For all reading devices , the chassis can alternatively be connected to the power supply ground signal (GND) or it can be left floating (remove the jumper).

Chassis Grounding

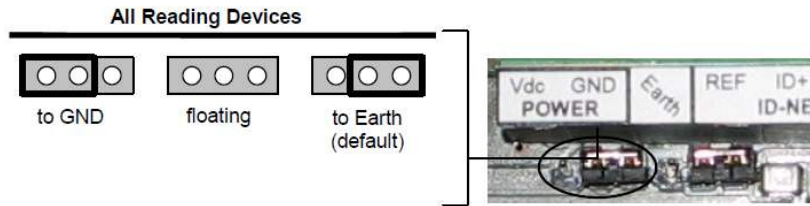

9-Pin Reading Device Auxiliary Serial Interface

Use the reading device auxiliary serial interface available on the internal TCNM-ACBB1 9-pin connector for configuration or data monitoring.

Connect the device to a PC or Laptop using a straight through cable or a USB-RS232 converter. The connector pins are listed in the following table.

TCNM-ACBB1 9-pin Female Connector Pinout			
Pin	Name	Function	
2	TX	Auxiliary RS232	
3	RX	Auxiliary RS232	
5	SGND	Auxiliary Reference Ground	
1, 4, 6, 7, 8, 9		N.C.	

Network Bus Termination

The ID-NET termination resistance switch enables or disables the insertion of the bus termination resistor for ID-NET network applications.

ID-NET Termination Resistance Switch

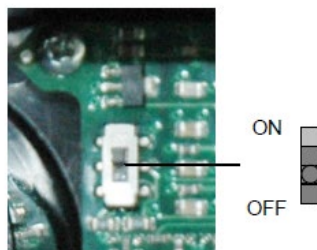

In ID-NET network applications, enable the termination resistor (ON) on the first and last devices of the chain. On all the other devices, disable this resistor (OFF).

The RS485 HD termination resistance switch enables or disables the insertion of the bus termination resistor for RS485 Half Duplex Multidrop applications.

RS485 HD Termination Resistance Switch

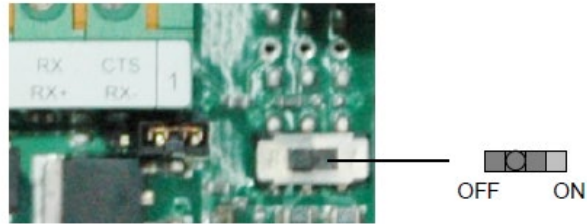

In Multiplexer applications, enable the termination resistor (ON) ONLY on the last device of the chain, the farthest away from the Multiplexer (assuming the Multiplexer is the first device of the chain). On all the other devices, disable this resistor (OFF).

TCNM-ACMK-100 Backup and Restore Module (Accessory)

The TCNM-ACMK-100 Backup and Restore Module (separate accessory) provides configuration parameter backup. It can easily be installed by aligning it over its corresponding connector in the TCNM-ACBB1 and pushing down until correctly seated. When closed, the plastic support inside the TCNM-ACBB1 cover holds the module in place. For further details see the TCNM-ACMK-100 manual.

TCNM-ACMK-100 Accessory Mounting

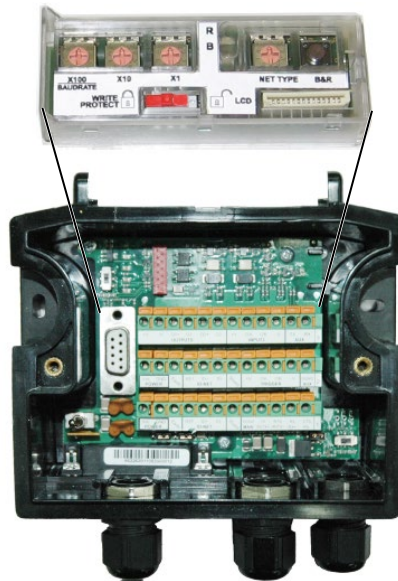

Indicator LEDs

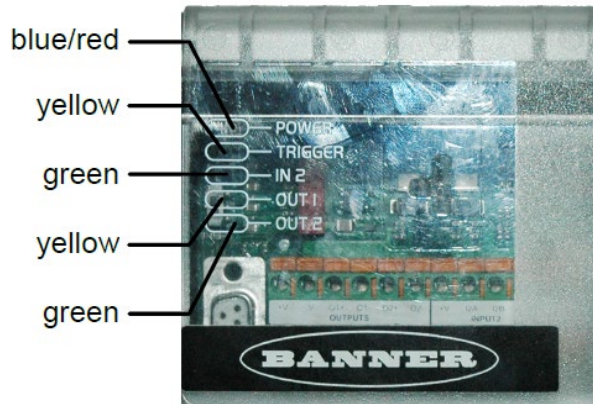

There are five Indicator LEDs that signal power and I/O activity and are visible from the outside cover. The Power LED is blue when power is correctly applied to the TCNM-ACBB1 and the power switch is turned on. This LED is red if power polarity is incorrect. In this case, the connected reading device and optional Backup Module are protected.



If external I/O devices are powered through TCNMACBB1 (connected to +V/-V), they are not protected from polarity inversion.

The remaining four LEDs signal activity on the relative I/O lines. Their meaning depends on the software configuration of the connected reading device.

Specifications

Electrical

Supply Voltage
10 to 30V dc
Consumption
0.5 to 0.3 A

Limited Current Consumption TCNM-ACBB1 +
reading device consumption (see related
manual)
2.5 A max.

User Interface

LED Indicators
Power ON/Polarity Error (blue/red)
Trigger (amber/yellow)
IN2 (green)
OUT1 (amber/yellow)
OUT2 (green)

Physical Features

Mechanical Dimensions
138 x 128 x 62 mm (5.4 x 5 x 2.4 inches)

Weight
about 380 grams (13.40 ounces)

Environmental Features

Operating Temperature

0 to 50 °C (+32 to 122 °F)

Storage Temperature

-20 to 70 °C (-4 to 158 °F)

Humidity max.

90% non condensing

Vibration Resistance (EN 60068-2-6) 2 hours on each axis

14 mm @ 2 to 10 Hz

1.5 mm @ 13 to 55 Hz

2 g @ 70 to 200 Hz

Shock Resistance (EN 60068-2-27)

30 g; 11 ms

3 shocks on each axis

Protection Class (EN 60529)

IP65 (when compression connectors and reading device are correctly connected)

The features given are typical at a 25 °C ambient temperature (if not otherwise indicated).

* for details about minimum/maximum supply voltage refer to the manual of the connected reading device, since the minimum supply voltage required may be >10.