

N-channel 1050 V, 1 Ω typ., 6 A MDmesh™ K5
Power MOSFETs in TO-220, TO-220FP and TO-247 packages

Datasheet - production data

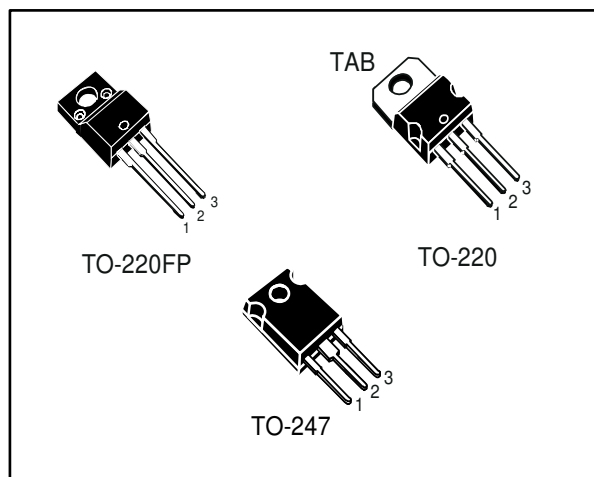
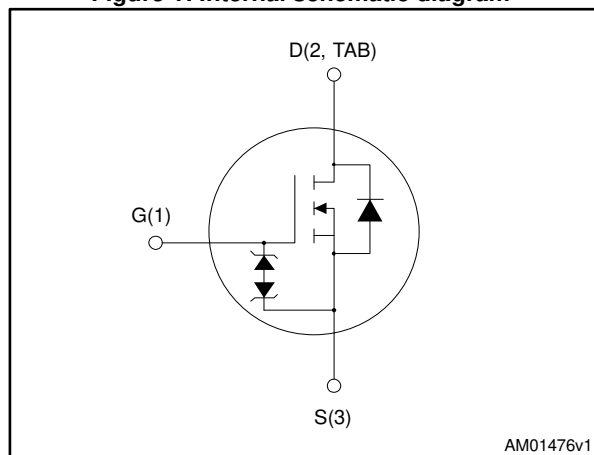

Figure 1: Internal schematic diagram



Features

Order codes	V _{DS}	R _{DS(on)} max.	I _D	P _{TOT}
STF10N105K5	1050 V	1.3 Ω	6 A	30 W
STP10N105K5				130 W
STW10N105K5				130 W

- Industry's lowest R_{DS(on)}
- Industry's best figure of merit (FoM)
- Ultra low gate charge
- 100% avalanche tested
- Zener-protected

Applications

- Switching applications

Description

These very high voltage N-channel Power MOSFETs are designed using MDmesh™ K5 technology based on an innovative proprietary vertical structure. The result is a dramatic reduction in on-resistance and ultra-low gate charge for applications requiring superior power density and high efficiency.

Table 1: Device summary

Order codes	Marking	Package	Packaging
STF10N105K5	10N105K5	TO-220FP	Tube
STP10N105K5	10N105K5	TO-220	Tube
STW10N105K5	10N105K5	TO-247	Tube

Contents

1	Electrical ratings	3
2	Electrical characteristics	4
	2.1 Electrical characteristics (curves).....	6
3	Test circuits	9
4	Package mechanical data	10
	4.1 TO-220 package mechanical data	11
	4.2 TO-247 package mechanical data	13
	4.3 TO-220FP package mechanical data.....	15
5	Revision history	17

1 Electrical ratings

Table 2: Absolute maximum ratings

Symbol	Parameter	Value			Unit
		TO-220	TO-247	TO-220FP	
V_{GS}	Gate- source voltage	30			V
I_D	Drain current (continuous) at $T_C = 25\text{ °C}$	6			A
I_D	Drain current (continuous) at $T_C = 100\text{ °C}$	3.78			A
$I_{DM}^{(1)}$	Drain current (pulsed)	24			A
P_{TOT}	Total dissipation at $T_C = 25\text{ °C}$	130		30	W
I_{AR}	Max. current during repetitive or single pulse avalanche	2			A
E_{AS}	Single pulse avalanche energy (starting $T_J = 25\text{ °C}$, $I_D = I_{AS}$, $V_{DD} = 50\text{ V}$)	140			mJ
$dv/dt^{(2)}$	Peak diode recovery voltage slope	4.5			V/ns
$dv/dt^{(3)}$	MOSFET dv/dt ruggedness	50			V/ns
V_{ISO}	Insulation withstand voltage (RMS) from all three leads to external heatsink ($t = 1\text{ s}$; $T_C = 25\text{ °C}$)			2500	V
T_j T_{stg}	Operating junction temperature Storage temperature	-55 to 150			°C

Notes:

⁽¹⁾Pulse width limited by safe operating area.

⁽²⁾ $I_{SD} \leq 6\text{ A}$, $di/dt \leq 100\text{ A}/\mu\text{s}$, $V_{peak} \leq V_{(BR)DSS}$.

⁽³⁾ $V_{SD} \leq 840$.

Table 3: Thermal data

Symbol	Parameter	Value			Unit
		TO-220	TO-247	TO-220FP	
$R_{thj-case}$	Thermal resistance junction-case max.	0.96			°C/W
	Thermal resistance junction-case max.			4.2	
$R_{thj-amb}$	Thermal resistance junction-ambient max.	62.50			°C/W

2 Electrical characteristics

($T_{\text{case}} = 25\text{ °C}$ unless otherwise specified)

Table 4: On /off states

Symbol	Parameter	Test conditions	Min.	Typ.	Max.	Unit
$V_{(\text{BR})\text{DSS}}$	Drain-source breakdown voltage	$I_D = 1\text{ mA}$, $V_{\text{GS}} = 0$	1050			V
I_{DSS}	Zero gate voltage, drain current ($V_{\text{GS}} = 0$)	$V_{\text{DS}} = 1050\text{ V}$			1	μA
		$V_{\text{DS}} = 1050\text{ V}$, $T_C = 125\text{ °C}$			50	μA
I_{GSS}	Gate-body leakage current	$V_{\text{GS}} = \pm 20\text{ V}$; $V_{\text{DS}} = 0$			10	μA
$V_{\text{GS(th)}}$	Gate threshold voltage	$V_{\text{DS}} = V_{\text{GS}}$, $I_D = 100\text{ }\mu\text{A}$	3	4	5	V
$R_{\text{DS(on)}}$	Static drain-source on- resistance	$V_{\text{GS}} = 10\text{ V}$, $I_D = 3\text{ A}$		1	1.3	Ω

Table 5: Dynamic

Symbol	Parameter	Test conditions	Min.	Typ.	Max.	Unit
C_{iss}	Input capacitance	$V_{\text{DS}} = 100\text{ V}$, $f = 1\text{ MHz}$, $V_{\text{GS}} = 0$		545		μF
C_{oss}	Output capacitance			30		μF
C_{riss}	Reverse transfer capacitance			1.3		μF
$C_{\text{o(tr)}}^{(1)}$	Equivalent capacitance time related	$V_{\text{GS}} = 0$, $V_{\text{DS}} = 0$ to 840 V		65		μF
$C_{\text{o(er)}}^{(2)}$	Equivalent capacitance energy related			22		μF
R_{G}	Intrinsic gate resistance	$f = 1\text{ MHz}$ open drain		7		Ω
Q_{g}	Total gate charge	$V_{\text{DD}} = 840\text{ V}$, $I_D = 6\text{ A}$ $V_{\text{GS}} = 10\text{ V}$		21.5		nC
Q_{gs}	Gate-source charge			3.3		nC
Q_{gd}	Gate-drain charge			15.5		nC

Notes:

⁽¹⁾Time related is defined as a constant equivalent capacitance giving the same charging time as C_{oss} when V_{DS} increases from 0 to 80% V_{DSS} .

⁽²⁾Energy related is defined as a constant equivalent capacitance giving the same stored energy as C_{oss} when V_{DS} increases from 0 to 80% V_{DSS} .

Table 6: Switching times

Symbol	Parameter	Test conditions	Min.	Typ.	Max.	Unit
$t_{\text{d(on)}}$	Turn-on delay time	$V_{\text{DD}} = 525\text{ V}$, $I_D = 3\text{ A}$, $R_{\text{G}} = 4.7\text{ }\Omega$, $V_{\text{GS}} = 10\text{ V}$		19		ns
t_{r}	Rise time			8		ns
$t_{\text{d(off)}}$	Turn-off-delay time			50		ns
t_{f}	Fall time			21.5		ns

Table 7: Source-drain diode

Symbol	Parameter	Test conditions	Min.	Typ.	Max.	Unit
I_{SD}	Source-drain current				6	A
$I_{SDM}^{(1)}$	Source-drain current (pulsed)				24	A
$V_{SD}^{(2)}$	Forward on voltage	$I_{SD} = 6 \text{ A}, V_{GS} = 0$			1.5	V
t_{rr}	Reverse recovery time	$I_{SD} = 6 \text{ A}, di/dt = 100 \text{ A}/\mu\text{s}$ $V_{DD} = 60 \text{ V}$	-	345		ns
Q_{rr}	Reverse recovery charge			3.53		μC
I_{RRM}	Reverse recovery current			20.5		A
t_{rr}	Reverse recovery time	$I_{SD} = 6 \text{ A}, di/dt = 100 \text{ A}/\mu\text{s}$ $V_{DD} = 60 \text{ V } T_J = 150 \text{ }^\circ\text{C}$		540		ns
Q_{rr}	Reverse recovery charge			5.05		μC
I_{RRM}	Reverse recovery current			18.5		A

Notes:

⁽¹⁾Pulse width limited by safe operating area.

⁽²⁾Pulsed: pulse duration = 300 μs , duty cycle 1.5%.

Table 8: Gate-source Zener diode

Symbol	Parameter	Test conditions	Min.	Typ.	Max.	Unit
$V_{(BR)GSO}$	Gate-source breakdown voltage	$I_{GS} = \pm 1 \text{ mA}, I_D = 0$	30	-	-	V

The built-in back-to-back Zener diodes have been specifically designed to enhance the ESD capability of the device. The Zener voltage is appropriate for efficient and cost-effective intervention to protect the device integrity. These integrated Zener diodes thus eliminate the need for external components.

2.1 Electrical characteristics (curves)

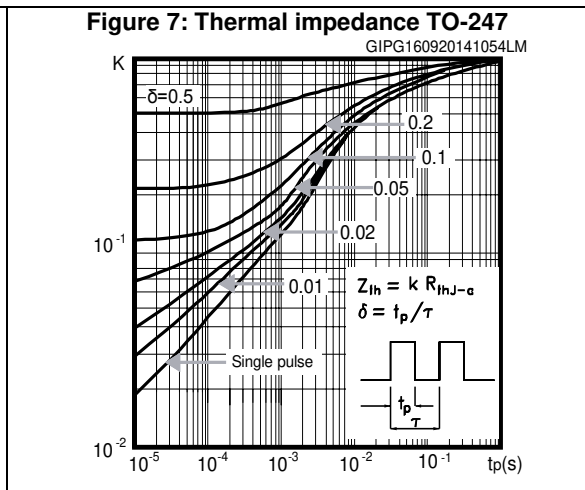
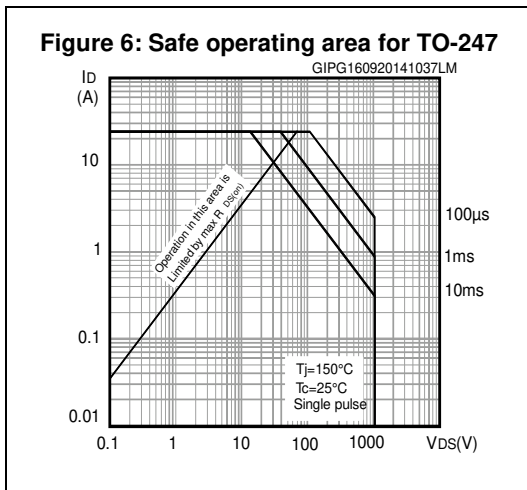
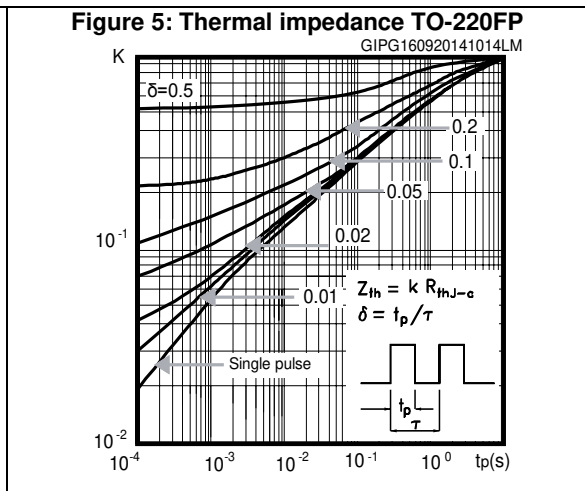
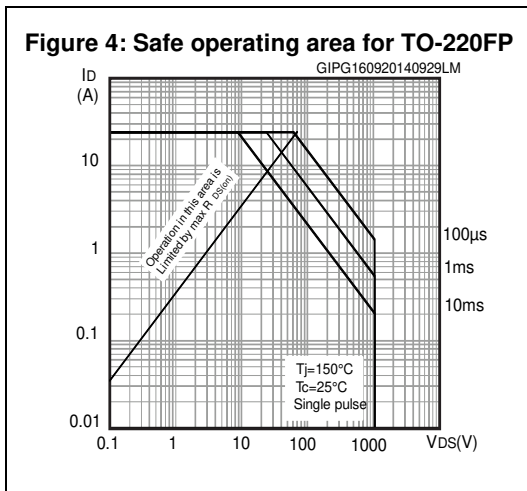
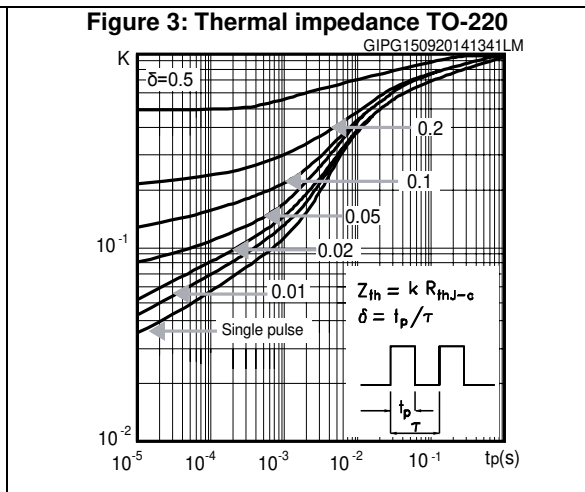
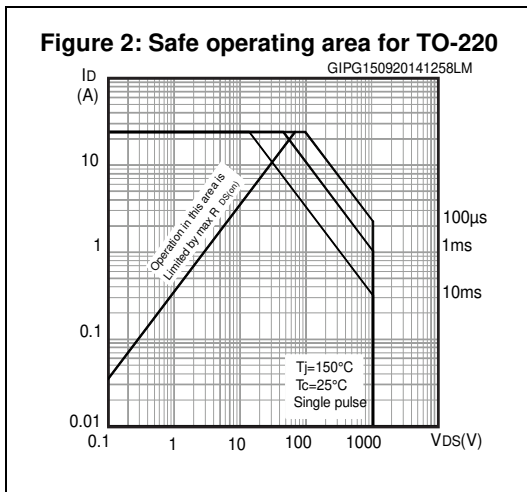

Figure 8: Output characteristics

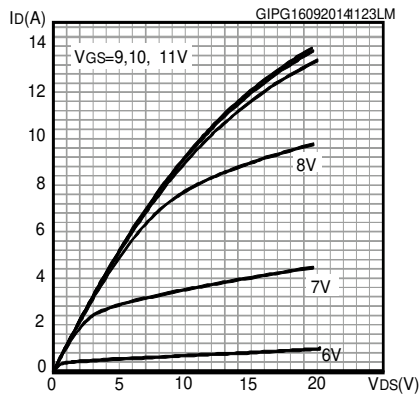

Figure 9: Transfer characteristics

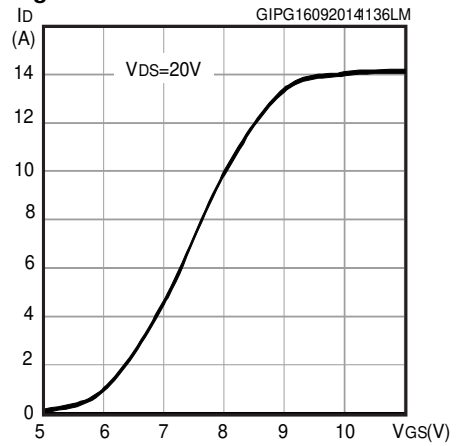

Figure 10: Gate charge vs gate-source voltage

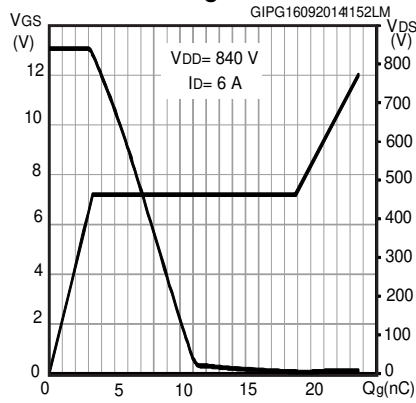

Figure 11: Static drain-source on-resistance

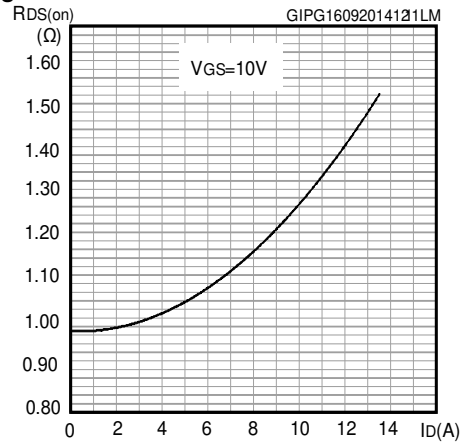

Figure 12: Capacitance variation

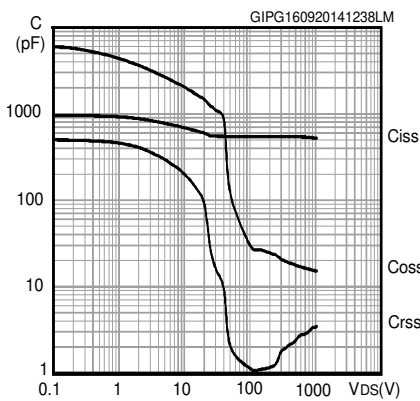

Figure 13: Normalized gate threshold voltage vs temperature

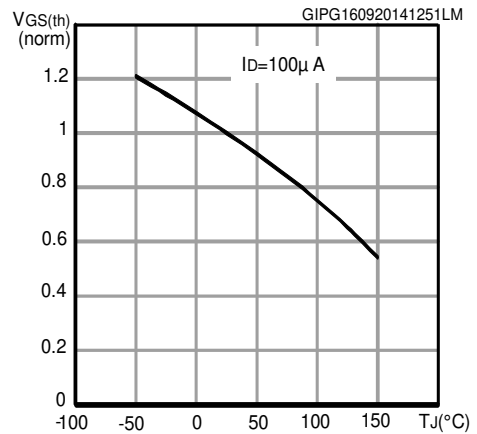

Figure 14: Normalized on-resistance vs temperature

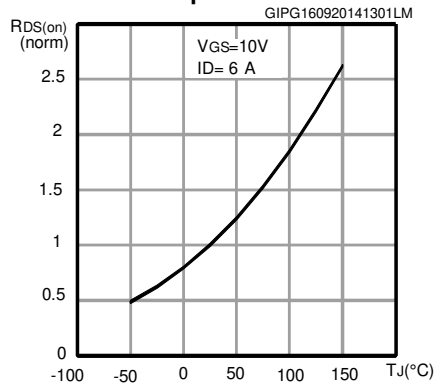

Figure 15: Source-drain diode forward characteristics

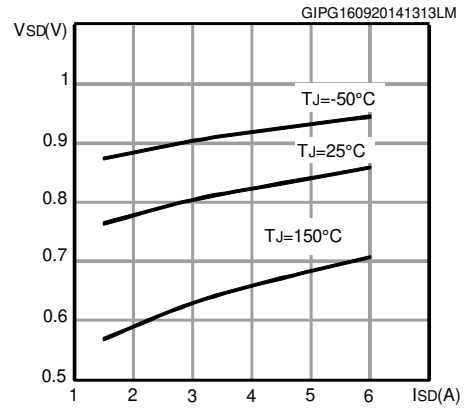

Figure 16: Normalized VBR(DSS) vs temperature

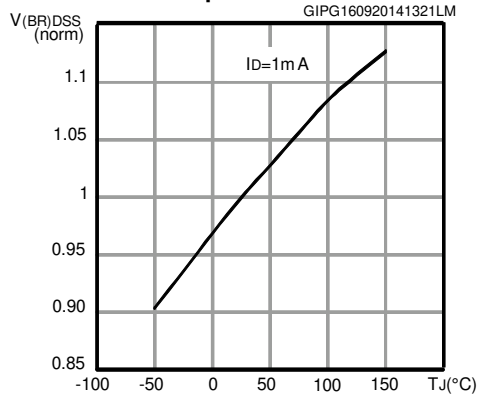
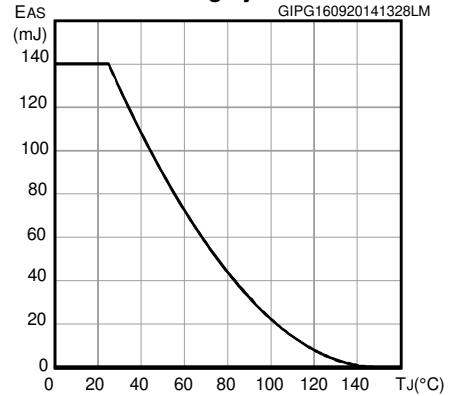
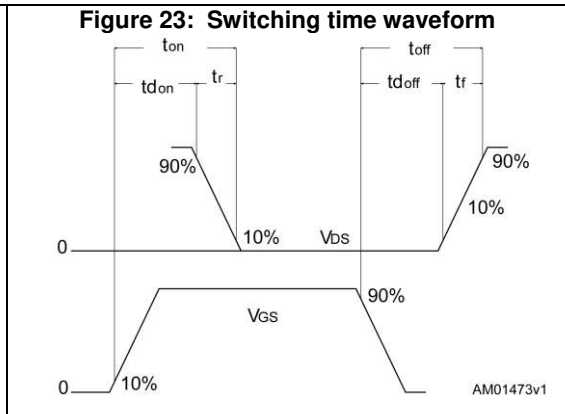
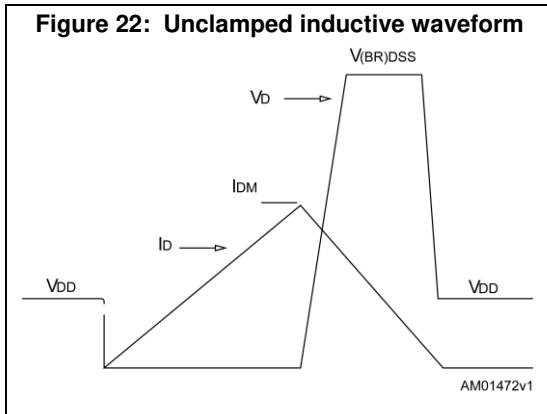
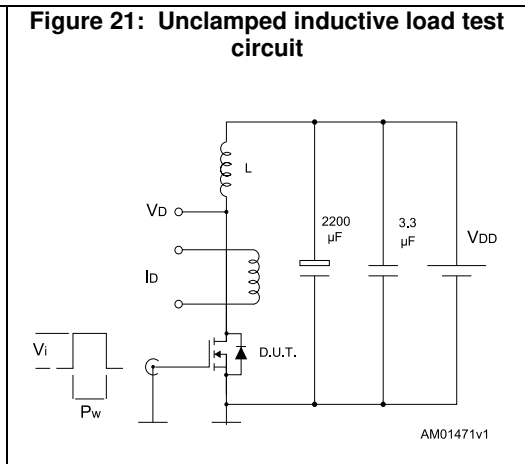
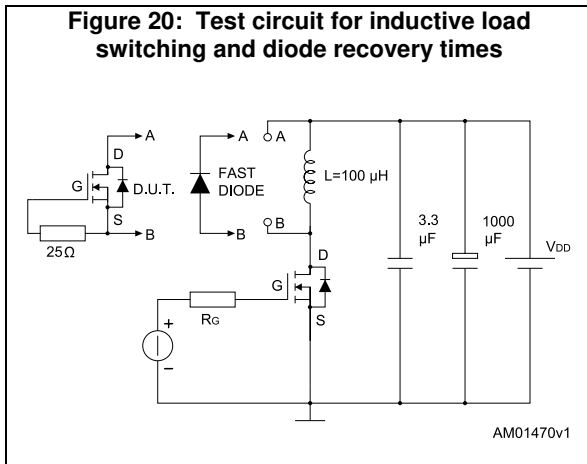
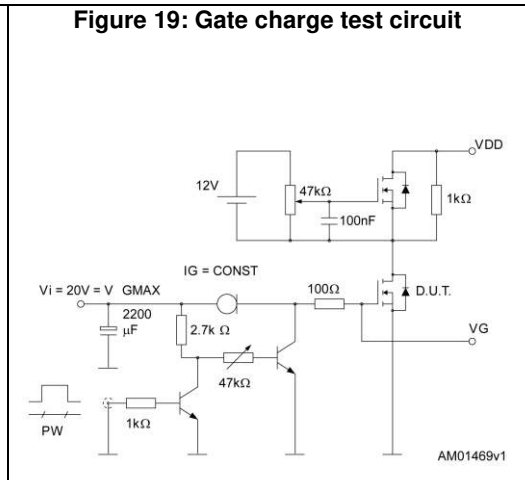
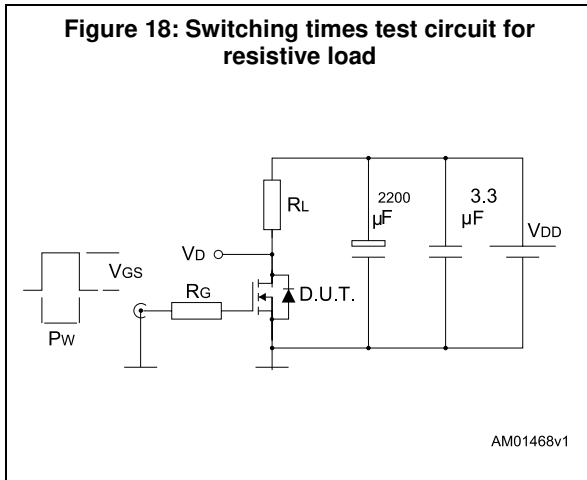

Figure 17: Maximum avalanche energy vs starting Tj



3 Test circuits



4 Package mechanical data

In order to meet environmental requirements, ST offers these devices in different grades of ECOPACK[®] packages, depending on their level of environmental compliance. ECOPACK[®] specifications, grade definitions and product status are available at: www.st.com. ECOPACK[®] is an ST trademark.

4.1 TO-220 package mechanical data

Figure 24: TO-220 type A drawings

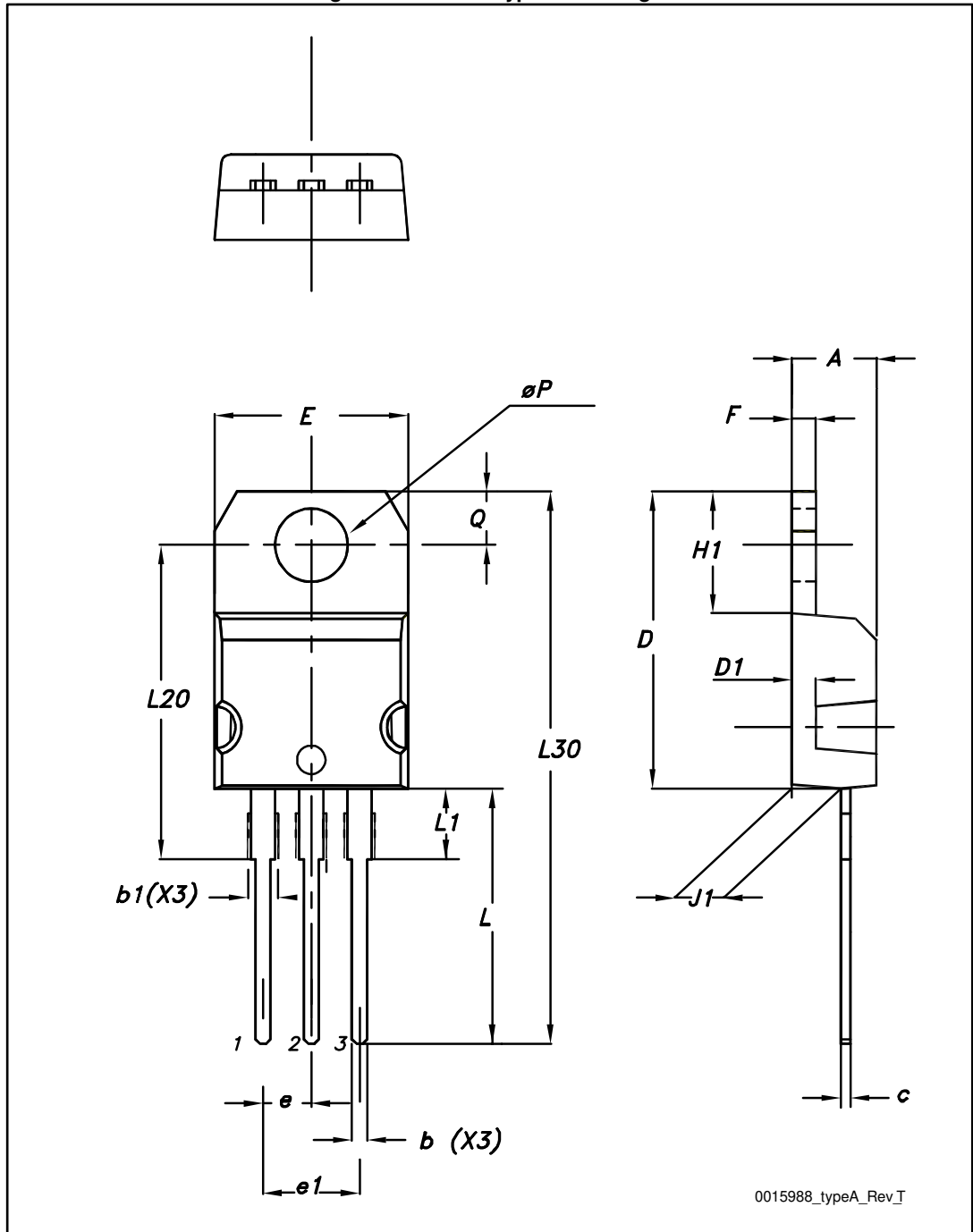

Table 9: TO-220 type A mechanical data

Dim.	mm		
	Min.	Typ.	Max.
A	4.40		4.60
b	0.61		0.88
b1	1.14		1.70
c	0.48		0.70
D	15.25		15.75
D1		1.27	
E	10		10.40
e	2.40		2.70
e1	4.95		5.15
F	1.23		1.32
H1	6.20		6.60
J1	2.40		2.72
L	13		14
L1	3.50		3.93
L20		16.40	
L30		28.90	
øP	3.75		3.85
Q	2.65		2.95

4.2 TO-247 package mechanical data

Figure 25: TO-247 drawings

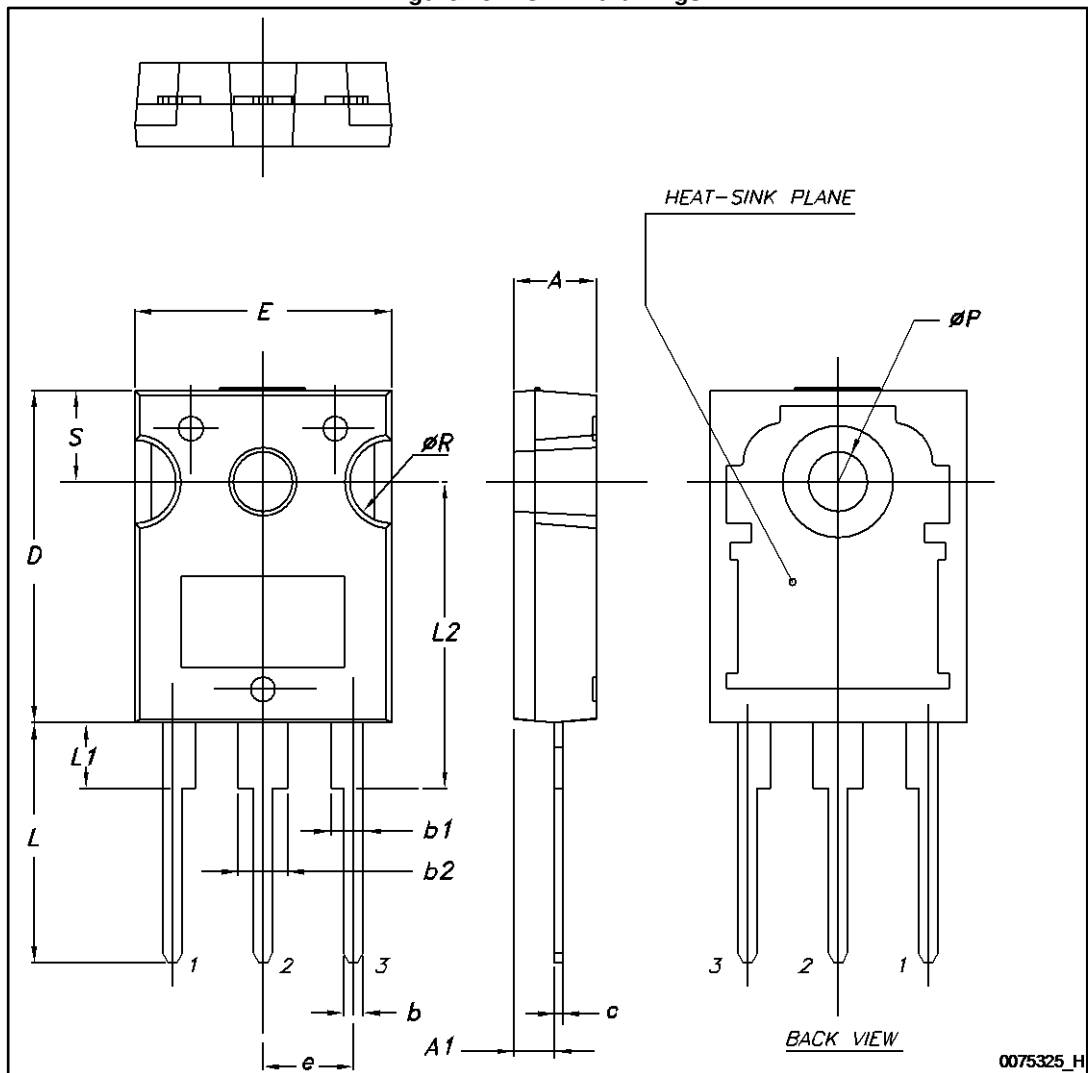

Table 10: TO-247 mechanical data

Dim.	mm		
	Min.	Typ.	Max.
A	4.85		5.15
A1	2.20		2.60
b	1.0		1.40
b1	2.0		2.40
b2	3.0		3.40
c	0.40		0.80
D	19.85		20.15
E	15.45		15.75
e	5.30	5.45	5.60
L	14.20		14.80
L1	3.70		4.30
L2		18.50	
øP	3.55		3.65
øR	4.50		5.50
S	5.30	5.50	5.70

4.3 TO-220FP package mechanical data

Figure 26: TO-220FP drawings

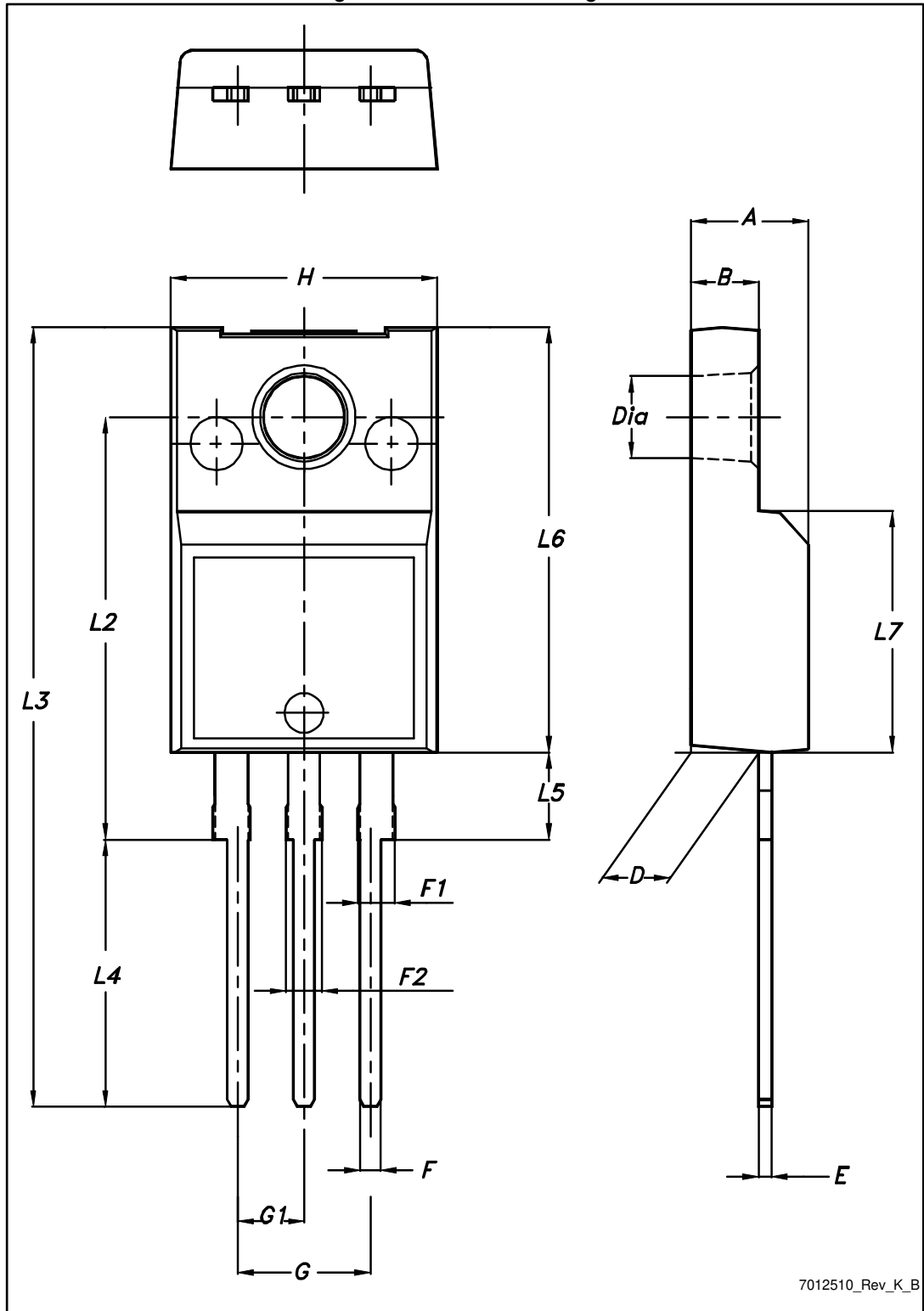

Table 11: TO-220FP mechanical data

Dim.	mm		
	Min.	Typ.	Max.
A	4.4		4.6
B	2.5		2.7
D	2.5		2.75
E	0.45		0.7
F	0.75		1
F1	1.15		1.70
F2	1.15		1.70
G	4.95		5.2
G1	2.4		2.7
H	10		10.4
L2		16	
L3	28.6		30.6
L4	9.8		10.6
L5	2.9		3.6
L6	15.9		16.4
L7	9		9.3
Ø	3		3.2

5 Revision history

Table 12: Document revision history

Date	Revision	Changes
07-Oct-2014	1	First release.
14-Oct-2014	2	Document status promoted from preliminary to production data.

IMPORTANT NOTICE – PLEASE READ CAREFULLY

STMicroelectronics NV and its subsidiaries ("ST") reserve the right to make changes, corrections, enhancements, modifications, and improvements to ST products and/or to this document at any time without notice. Purchasers should obtain the latest relevant information on ST products before placing orders. ST products are sold pursuant to ST's terms and conditions of sale in place at the time of order acknowledgement.

Purchasers are solely responsible for the choice, selection, and use of ST products and ST assumes no liability for application assistance or the design of Purchasers' products.

No license, express or implied, to any intellectual property right is granted by ST herein.

Resale of ST products with provisions different from the information set forth herein shall void any warranty granted by ST for such product.

ST and the ST logo are trademarks of ST. All other product or service names are the property of their respective owners.

Information in this document supersedes and replaces information previously supplied in any prior versions of this document.

© 2014 STMicroelectronics – All rights reserved