

This document is the property of Amphenol Corporation and is delivered on the express condition that it is not to be disclosed, reproduced or used, in whole or in part, for manufacture or sale by anyone other than Amphenol Corporation without its prior consent, and that no right is granted to disclose or to use any information in this document.

The marking on this product doesn't contain environmental hazardous materials per Material Specification SS-00259 for Sony GP compliant or per directive 2011/65/EU for RoHS compliant.

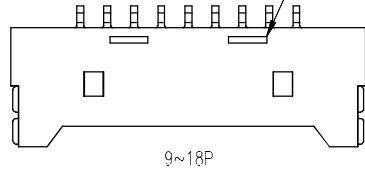
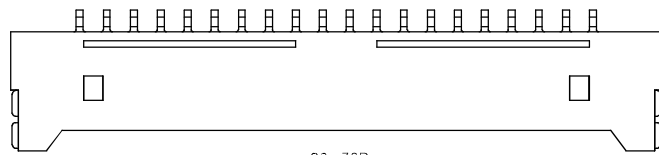
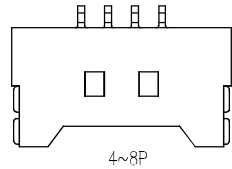
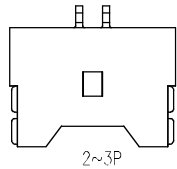

REVISIONS				
SYM	ECN No.	DESCRIPTION	DATE	APPROVED
A	ME-13087	RELEASE TO PRODUCTION	06/21/2013	Roger Tsai
B	NE-15075	ADDED DIMENSION & SLOT OPTION	07/16/2015	Roger Tsai

**ORIGINAL**

**NOTES:**

- INSULATOR: LCP, UL 94V-0, COLOR-WHITE.
- CONTACT: PHOSPHOR BRONZE, GOLD FLASH PLATING ON CONTACT AREA, GOLD FLASH PLATING ON SOLDERING AREA.  
OVER 50μ" MIN. NICKEL UNDER-PLATING OVERALL  
SOLDER TAB: PHOSPHOR BRONZE, 60 μ" MATTE-TIN,  
OVER 50μ" MIN. NICKEL UNDER-PLATING OVERALL
- THIS PRODUCT DOESN'T CONTAIN ENVIRONMENTAL HAZARDOUS MATERIAL PER DIRECTIVE 2011/65/EU FOR RoHS.
- PACKING MUST BE PER Amphenol PACKING SPECIFICATION PKS-0001

G880 30 221 T2EU	30	36.25	42.65	22.50	31.92
G880 28 221 T2EU	28	33.75	40.15	22.50	30.67
G880 26 221 T2EU	26	31.25	37.65	22.50	29.42
G880 24 221 T2EU	24	28.75	35.15	22.50	28.17
G880 22 221 T2EU	22	26.25	32.65	22.50	26.92
G880 20 221 T2EU	20	23.75	30.15	22.50	25.67
G880 18 221 T2EU	18	21.25	27.65	20.00	24.42
G880 16 221 T2EU	16	18.75	25.15	17.50	23.17
G880 15 221 T2EU	15	17.50	23.90	16.25	21.92
G880 14 221 T2EU	14	16.25	22.65	15.00	20.67
G880 13 221 T2EU	13	15.00	21.40	13.75	19.42
G880 12 221 T2EU	12	13.75	20.15	12.50	18.17
G880 11 221 T2EU	11	12.50	18.90	11.25	16.92
G880 10 221 T2EU	10	11.25	17.65	10.00	15.67
G880 09 221 T2EU	9	10.00	16.40	8.75	14.42
G880 08 221 T2EU	8	8.75	15.15	7.50	13.17
G880 07 221 T2EU	7	7.50	13.90	6.25	11.92
G880 06 221 T2EU	6	6.25	12.65	5.00	10.67
G880 05 221 T2EU	5	5.00	11.40	3.75	9.42
G880 04 221 T2EU	4	3.75	10.15	2.50	8.17
G880 03 221 T2EU	3	2.50	8.90	--	6.92
G880 02 221 T2EU	2	1.25	7.65	--	5.67

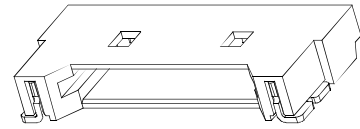
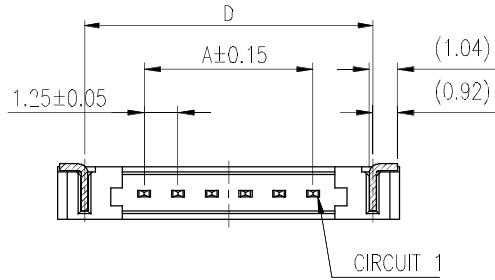

PART NO. G880 XX 221T2EU  
NO. OF POS. SEE TABLE

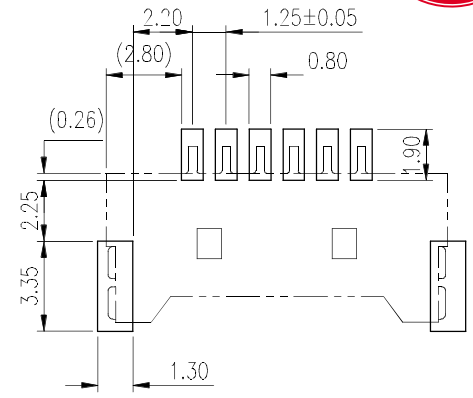
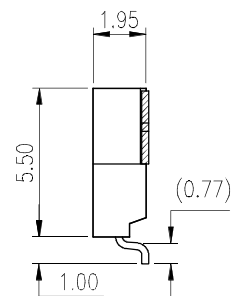
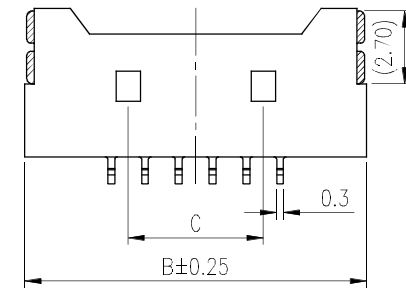

RECOMMENDED PCB LAYOUT  
ALL TOLERANCE ±0.05

TOLERANCE	APPROVALS	DATE	TITLE		PART No.			
X. ±0.30	DRAWN Aqua Chou	07/16/2015	G880 SERIES, WTB CONN. 1.25 PITCH, PROTECT HEADER R/A SMT TYPE		Amphenol® Amphenol Corporation Amphenol Taiwan Corporation			
X.X ±0.20	CHECKED Roger Tsai	07/16/2015						
X.XXX ±0.10	APPROVED Roger Tsai	07/16/2015						
ANGULAR ±1°	DWG TYPE CUST DWG	PROJECT CODE PHD	UNIT mm	SIZE A3	PART No. G880XX221T2EU			
UNLESS OTHERWISE SPECIFIED			SCALE NA	SHEET 1 OF 3	DWG No. G880XX221T2EU REV. B			

PART NUMBER

NO. OF POSITIONS

DIMENSIONS  
A B C D

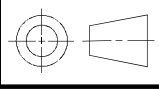

UNIT mm  
SCALE NA

SIZE A3  
SHEET 1 OF 3

PART No. G880XX221T2EU  
DWG No. G880XX221T2EU REV. B

This document is the property of Amphenol Corporation and is delivered on the express condition that it is not to be disclosed, reproduced or used, in whole or in part, for manufacture or sale by anyone other than Amphenol Corporation without its prior consent, and that no right is granted to disclose or to use any information in this document.

The marking on this product doesn't contain environmental hazardous materials per Material Specification SS-00259 for Sony GP compliant or per directive 2011/65/EU for RoHS compliant.



ORIGINAL



REVISIONS				
SYM	ECN No.	DESCRIPTION	DATE	APPROVED
A	NE-13087	RELEASE TO PRODUCTION	06/21/2013	Roger Tsai
B	NE-15075	ADDED DIMENSION & SLOT OPTION	07/16/2015	Roger Tsai

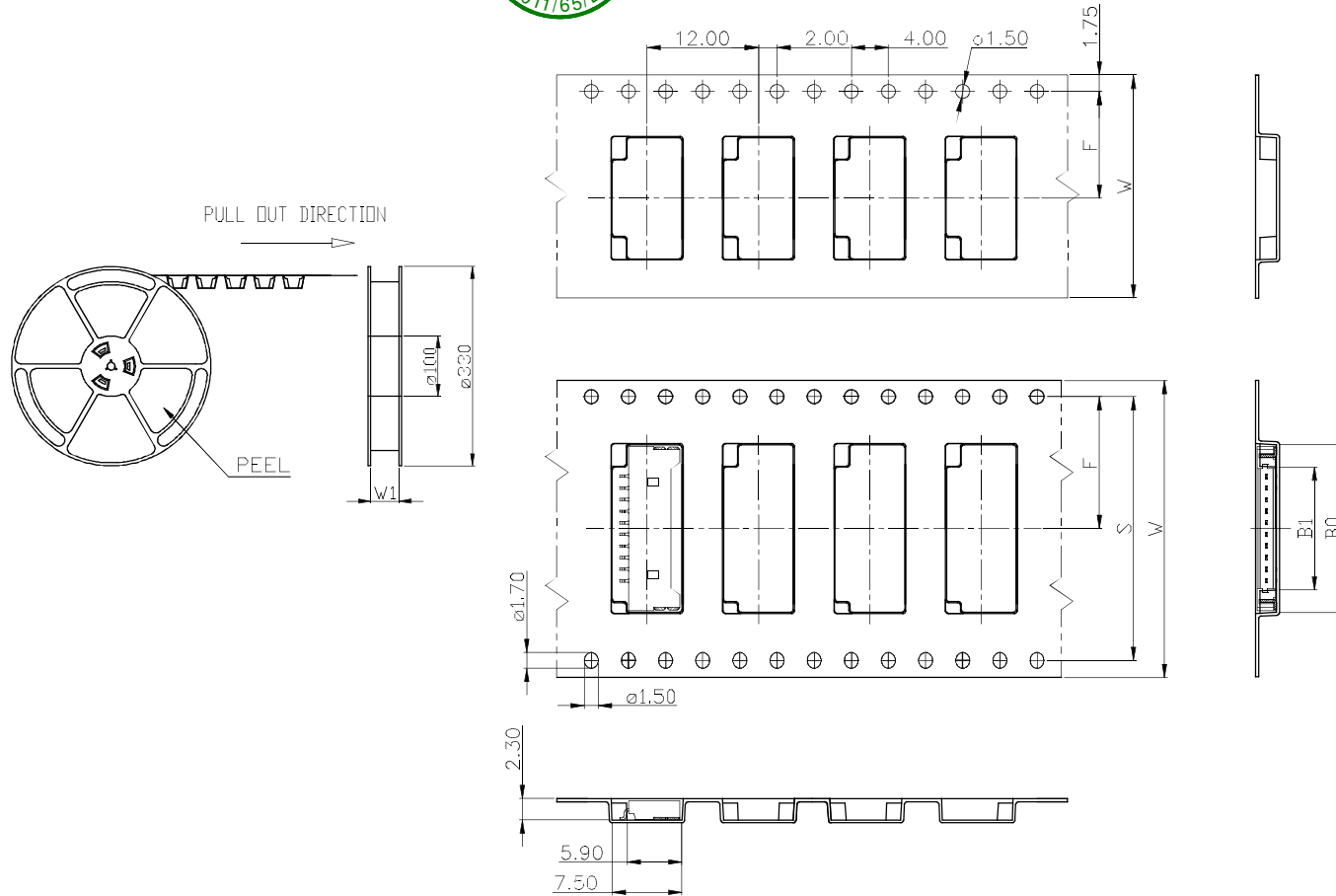

NO. OF POSITIONS	DIMENSIONS					
	B0	B1	F	W	W1	S
2	8.00	3.20	7.50	16.00	16.50	
3	9.25	4.45	7.50	16.00	16.50	
4	10.50	5.70	11.50	24.00	24.50	
5	11.75	6.95	11.50	24.00	24.50	
6	13.00	8.20	11.50	24.00	24.50	
7	14.25	9.45	11.50	24.00	24.50	
8	15.50	10.70	11.50	24.00	24.50	
9	16.75	11.95	11.50	24.00	24.50	
10	18.00	13.20	14.20	32.00	32.50	28.40
11	19.25	14.45	14.20	32.00	32.50	28.40
12	20.50	15.70	14.20	32.00	32.50	28.40
13	21.75	16.95	14.20	32.00	32.50	28.40
14	23.00	18.20	20.20	44.00	44.50	40.40
15	24.25	19.45	20.20	44.00	44.50	40.40
16	25.50	20.70	20.20	44.00	44.50	40.40
18	28.00	23.20	20.20	44.00	44.50	40.40
20	30.50	25.70	20.20	44.00	44.50	40.40
22	33.00	28.20	20.20	44.00	44.50	40.40
24	35.50	30.70	26.20	56.00	56.50	52.40
26	38.00	33.20	26.20	56.00	56.50	52.40
28	40.50	35.70	26.20	56.00	56.50	52.40
30	43.00	38.20	26.20	56.00	56.50	52.40

- NOTES:
1. 10 SPROCKET HOLE PITCH CUMULATIVE TOLERANCE  $\pm 0.20$  .
  2. CARRIER CAMBER IS WITHIN 1 mm IN 250 mm.
  3. MATERIAL : BLACK CONDUCTIVE POLYSTYRENE ALLOY.(UP-5000)
  4. ALL DIMENSIONS MEET EIA-481-C REQUIREMENTS.
  5. THICKNESS :  $0.35 \pm 0.05$ mm.
  6. COMPONENT LOAD PER 13" REEL : 2000 PCS.

TOLERANCE	APPROVALS	DATE	TITLE		PART No.	
X. $\pm 0.30$ X.X $\pm 0.20$ X.XX $\pm 0.10$	DRAWN Aqua Chou	07/16/2015	G880 SERIES, WTB CONN. 1.25 PITCH, PROTECT HEADER R/A SMT TYPE		Amphenol <sup>®</sup> Amphenol Corporation Amphenol Taiwan Corporation	
ANGULAR $\pm 1^\circ$	CHECKED Roger Tsai	07/16/2015				
UNLESS OTHERWISE SPECIFIED	APPROVED Roger Tsai	07/16/2015	UNIT mm	SIZE A3	G880XX221T2EU	
	DWG TYPE CUST DWG	PROJECT CODE PHD	SCALE NA	SHEET 2 OF 3	DWG No.	G880XX221T2EU
					REV.	B

This document is the property of Amphenol Corporation and is delivered on the express condition that it not be disclosed, reproduced or used, in whole or in part, for manufacture or sale by anyone other than Amphenol Corporation without its prior consent, and that no right is granted to disclose or to use any information in this document.

The marking on this product doesn't contain environmental hazardous materials per Material Specification SS-00259 for Sony GP compliant or per directive 2011/65/EU for PbHS compliant.



ORIGINAL



REVISIONS				
SYM	ECN No.	DESCRIPTION	DATE	APPROVED
A	NE-13087	RELEASE TO PRODUCTION	06/21/2013	Roger Tsai
B	NE-15075	ADDED DIMENSION & SLOT OPTION	07/16/2015	Roger Tsai

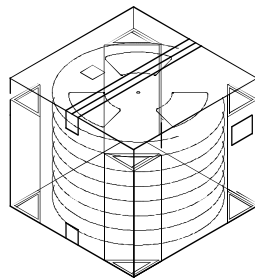
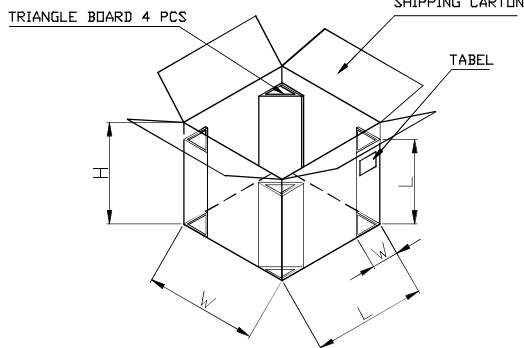
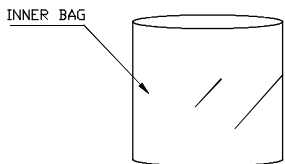
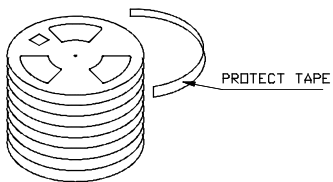
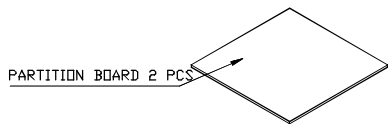

PACKING MATERIAL	
PART NAME	DIMENSION (mm)
REEL	ø330 X (W+5)
CARTON	350 X 350 X 340

NO. OF POSITIONS	PACKING CAPACITY		
	PCS/REEL	REEL/CARTON	PCS/CARTON
2	2000	14	28000
3	2000	14	28000
4	2000	10	20000
5	2000	10	20000
6	2000	10	20000
7	2000	10	20000
8	2000	10	20000
9	2000	10	20000
10	2000	8	16000
11	2000	8	16000
12	2000	8	16000
13	2000	8	16000
14	2000	6	12000
15	2000	6	12000
16	2000	6	12000
18	2000	6	12000
20	2000	6	12000
22	2000	6	12000
24	2000	6	12000
26	2000	5	10000
28	2000	5	10000
30	2000	5	10000

TOLERANCE	APPROVALS	DATE	TITLE		PART No.	
X. X.X ±0.30 X.XX ±0.20 X.XXX ±0.10	DRAWN Aqua Chou	07/16/2015	G880 SERIES, WTB CONN. 1.25 PITCH, PROTECT HEADER R/A SMT TYPE		<b>Amphenol</b> <sup>®</sup> Amphenol Corporation Amphenol Taiwan Corporation	
ANGULAR ±1°	CHECKED Roger Tsai	07/16/2015				
UNLESS OTHERWISE SPECIFIED	APPROVED Roger Tsai	07/16/2015				
	DWG TYPE CUST DWG	PROJECT CODE PHD	UNIT mm	SIZE A3	G880XX221T2EU	
			SCALE NA	SHEET 3 OF 3	G880XX221T2EU	
					REV. B	