

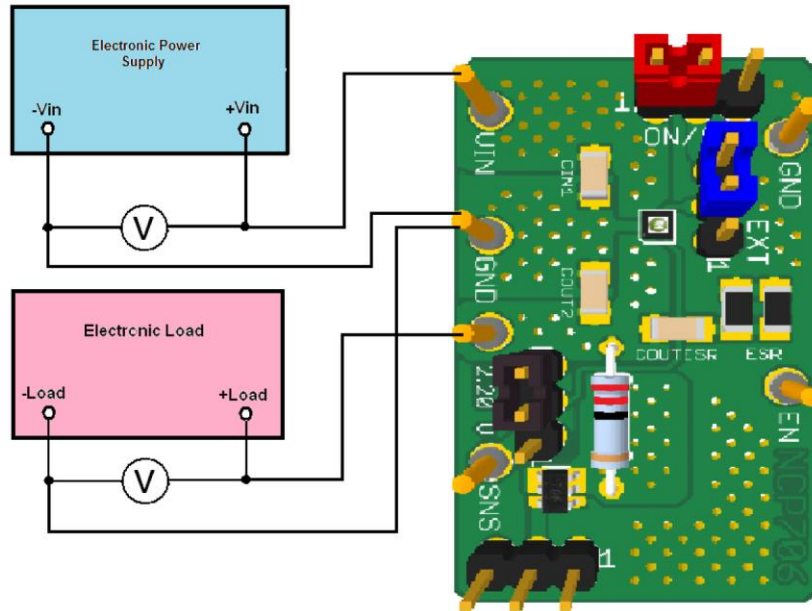

Test Procedure for the NCP706MX22TAGEVB Evaluation Board



Test procedure:

1. Check the position of jumpers and correct those if necessary in accordance with the picture above.
 - a) ON/OFF **RED**
 - b) EXT **BLUE**
 - c) SENSE **BLACK**
2. Connect the test setup as shown Figure above
3. Apply an input voltage **V_{in} = 2.5 V**
4. Apply I_{out} = 0mA load.
5. Check that V_{out} is **2.2 V +/-1%**.
6. Increase I_{out} up to **1A**
7. Check that V_{out} is **2.2 V +/-1%**.
7. Increase V_{in} up to **5.5 V** and decrease the load in accordance with **SOA**
8. Power down the Load
9. Power down the V_{cc}
10. End of test

Jumper functions description:

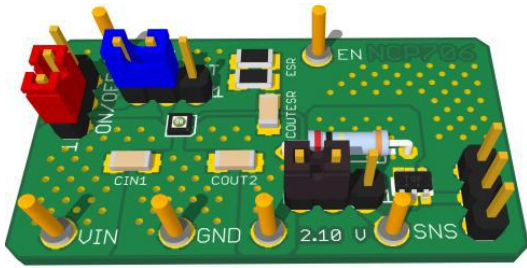

Internal ENABLE On state

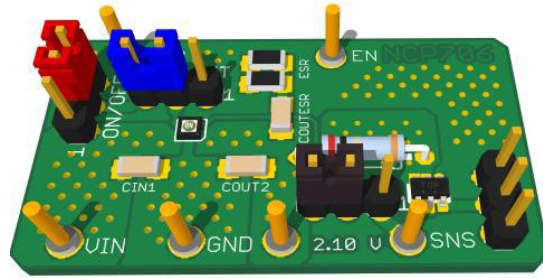

Internal ENABLE Off state

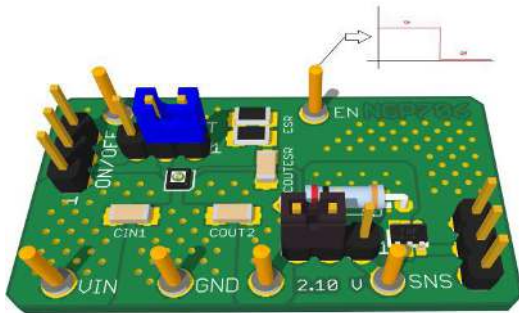

External ENABLE Signal

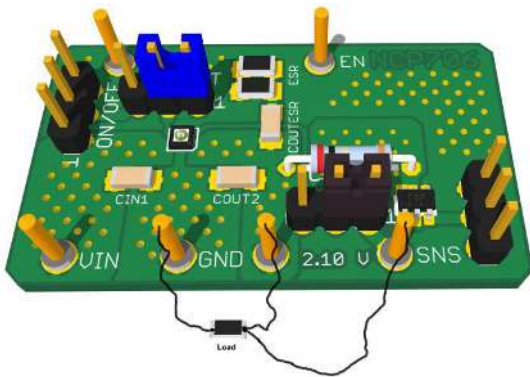

External SNS Signal, connect to positive load node for voltage drop at output and load wiring compensation.