

used for: FILTER ADAPTER

POS.	A ^{-0.76}	B1 ^{-0.25}	B2 ^{+0.25}	C	D ^{-0.3}	Part NO.
9	31.19	16.46	16.79	25.00 ^{+0.12} _{-0.13}	6.12	243A12160X
15	39.52	24.79	25.12	33.30 ^{+0.15} _{-0.1}	6.12	243A12170X
25	53.42	38.50	38.84	47.04 ^{+0.13}	5.99	243A12180X
37	69.70	54.96	55.30	63.50 ^{+0.13}	5.99	243A12190X

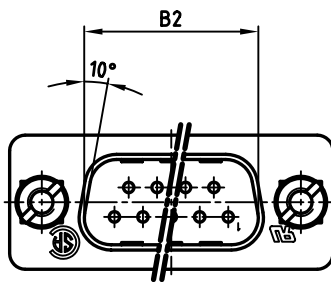
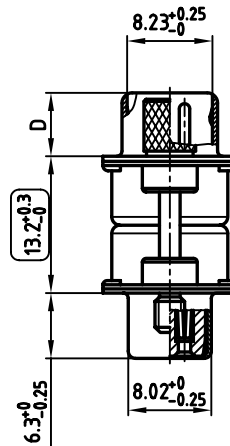
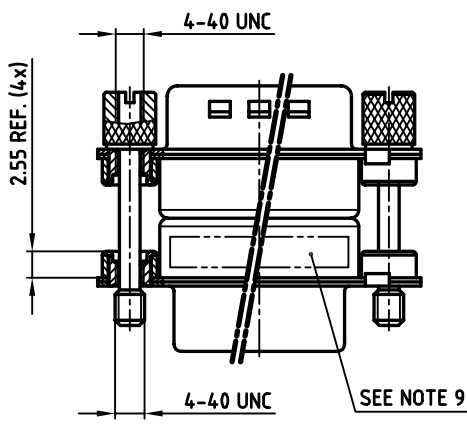
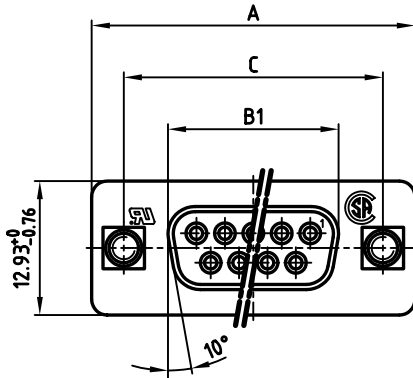

NOTES:

- METALSHELLS: STEEL; min. 320µ" TIN
- INSULATORS: PBT GF UL 94 V-0, BLACK
- CONTACTS: COPPER ALLOY
PLATING: 8µ" HARD GOLD OVER min. 50µ" NICKEL
- THREADED INSERT: COPPER ALLOY; min. 200µ" TIN over 80µ" NICKEL
- COLLAR: COPPER ALLOY; min. 200µ" TIN over 80µ" NICKEL
- CAPACITANCE: 180pF ±20%
- DIELECTRIC WITHSTANDING VOLTAGE: 424 VDC
- MAXIMUM TORQUE VALUE FOR THREAD: 6" LBS
- CONNECTOR IS PART MARKED: [PART-NO. CONEC ABC]
- = CHECK DIMENSION

Directive 2002/95/EC
RoHS-Compliant

APPROVAL # FREIGABE # DEBLOCAGE # AUTORIZACION # APPROVAL	
CUSTOMER APPROVAL DATE:	
NAME:	TITLE:
COMPANY NAME:	
APPROVAL # FREIGABE # DEBLOCAGE # AUTORIZACION # APPROVAL	

THIS DRAWING MAY NOT BE COPIED OR REPRODUCED IN ANY WAY, AND MAY NOT BE PASSED ON TO A THIRD PARTY, WITHOUT WRITTEN PERMISSION.
OWNERSHIP AND COPYRIGHT OF CONEC GmbH
DO NOT ALTER CAD DRAWING BY HAND

rev.	description	date	name

tolerance		
2005	date	
drawn	12.10.	name
appd.	12.10.	Mickenbecker
norm		
d-old		
CONEC [®]		

scale:	2:1	
material:	SEE NOTES	
title:	FULL METAL C-FILTER ADAPTER	
	PLUG / SOCKET 9-37pos.	
	with jack screws	
dwg no:	AutoCAD 2004	DIN-A
	24K1A707	3
		sh: 1/1
part no:	SEE TABLE	