

NOTES:

1. FOR WAVESOLDERING (SOLDER BATH TEMPERATURE 265°C FOR 8 SEC. AND SOLDER PREHEAT 150°C FOR 180 SEC.)
2. IP RATING: IP 67
3. SEALED TO WITHSTAND PRESSURE UP TO 1,45 PSI FOR 30 MINUTES AFTER HIGH TEMPERATURE EXPOSURE
4. METAL SHELL:
 - ZINC DIE CAST; min. 50µin NICKEL PLATING over COPPER
5. INSULATORS: PBT GF UL 94 V-0, BLACK
6. O-RING: SILICONE PER ASTM D2000 70 SHORE A
7. SEALING COMPOUND: EPOXY RESIN UL 94 V-0; BLACK
8. CONTACTS: COPPER ALLOY PLATING (SEE PART NO):
 - PLEASE ADD 1 for 30µin HARD GOLD over min. 50µin NICKEL
 - PLEASE ADD 3 for 8µin HARD GOLD over min. 50µin NICKEL
9. METAL BRACKETS: ZINC DIE CAST; 300µin COPPER/40-120µin NICKEL/120-200µin TIN
10. WASHERS: COPPER ALLOY; 80µin NICKEL
11. HEXLOCKING SCREWS: STAINLESS STEEL
12. PCB-SNAPS: COPPER ALLOY; min. 200µin TIN over 80µin NICKEL PCB-HOLE: $\varnothing 3.1 \pm 0.1$; PCB THICKNESS 1.6mm
13. OPERATING TEMPERATURE: -40°C to +105°C (d)
14. P.C.B. HOLE DRILLINGS and RECOMMENDED PANEL CUT-OUT ON SHEET 2
15. RECOMMENDED TORQUE FOR MOUNTING SCREW 35Ncm (3.1 in.LB) / max.67Ncm (6 in.LB)
16. CONNECTOR IS PART MARKED: 15-00077 CONEC ABC

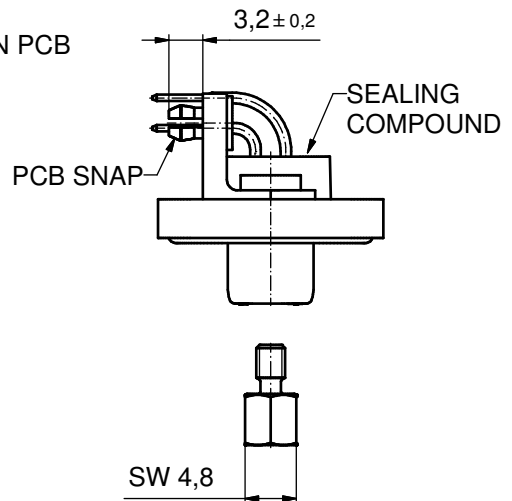
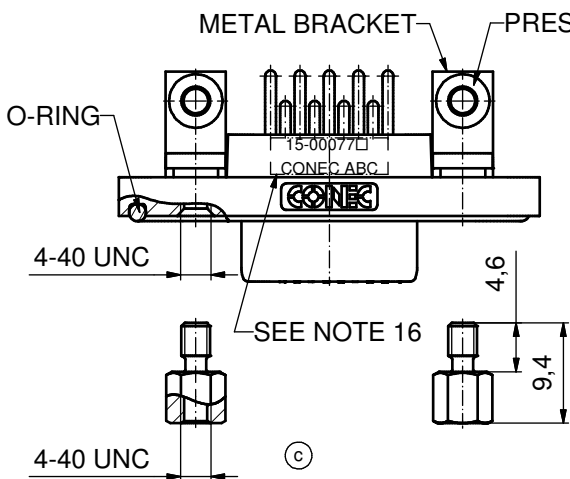
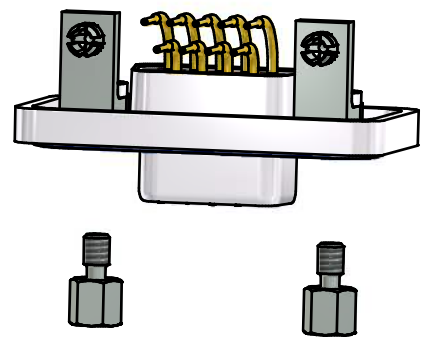
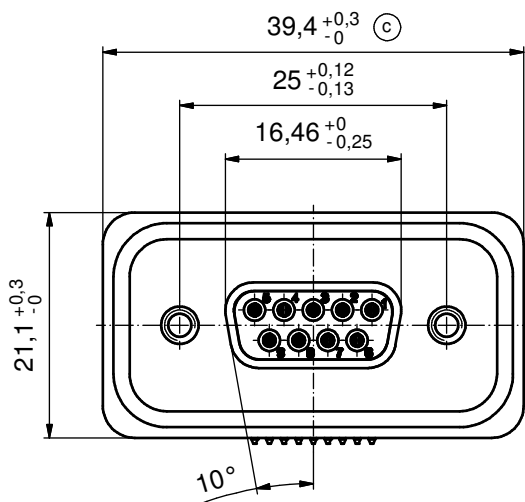
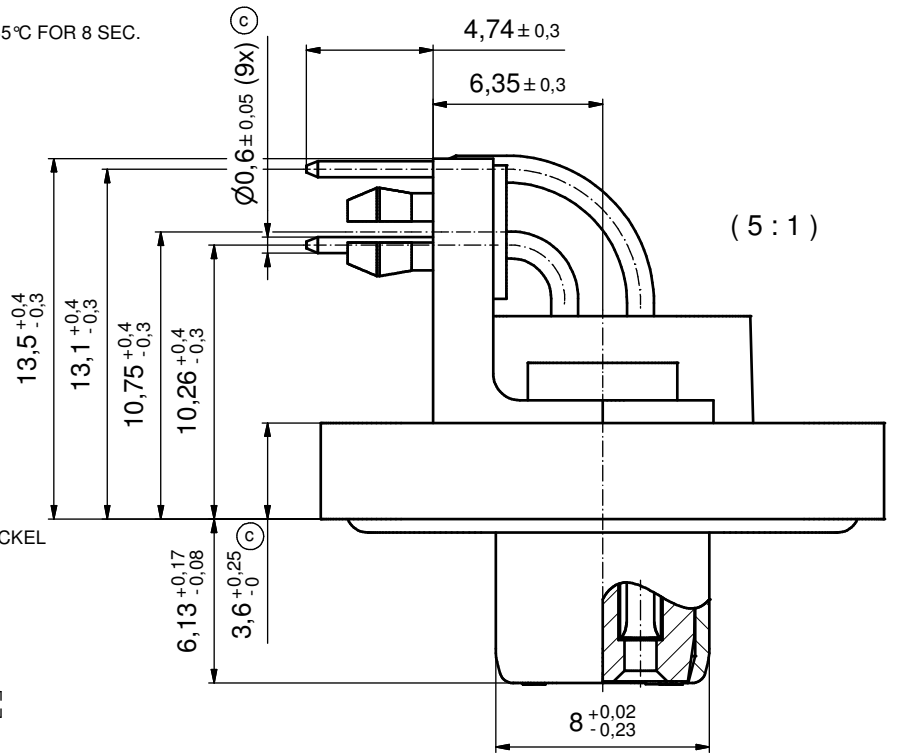

AT ALL TIMES WATER RESISTANT CONNECTORS NOT IN USE SHOULD BE COVERED WITH A CONEC WATER RESISTANT CAP OR WATER TIGHT HOOD.

RoHS compliant

THIS DRAWING MAY NOT BE COPIED OR REPRODUCED IN ANY WAY, AND MAY NOT BE PASSED ON TO A THIRD PARTY WITHOUT WRITTEN PERMISSION. OWNERSHIP AND COPYRIGHT OF CONEC GmbH DO NOT ALTER CAD DRAWING BY HAND				tolerance		scale: 2:1 (5:1)
					dim. in mm	material: see notes
				date	name	title: D-SUB FEMALE 90° 9pos. SOLDER PIN ANGLED with metal bracket, hexlocking screw and snap
				drawn 17.10.08	Schmidt	
				appd. 23.10.08	Fischer	
1 x d	Ä5468	05.01.15	K.H.	d-old	dwg no: 15K1A285	DIN-A3
4 x c	Ä3435	05.10.09	HS		part no: 15-00077 (see note 8)	sh: 1/2
a	Origin					
rev.	description	date	name			

P.C.B. HOLE DRILLINGS

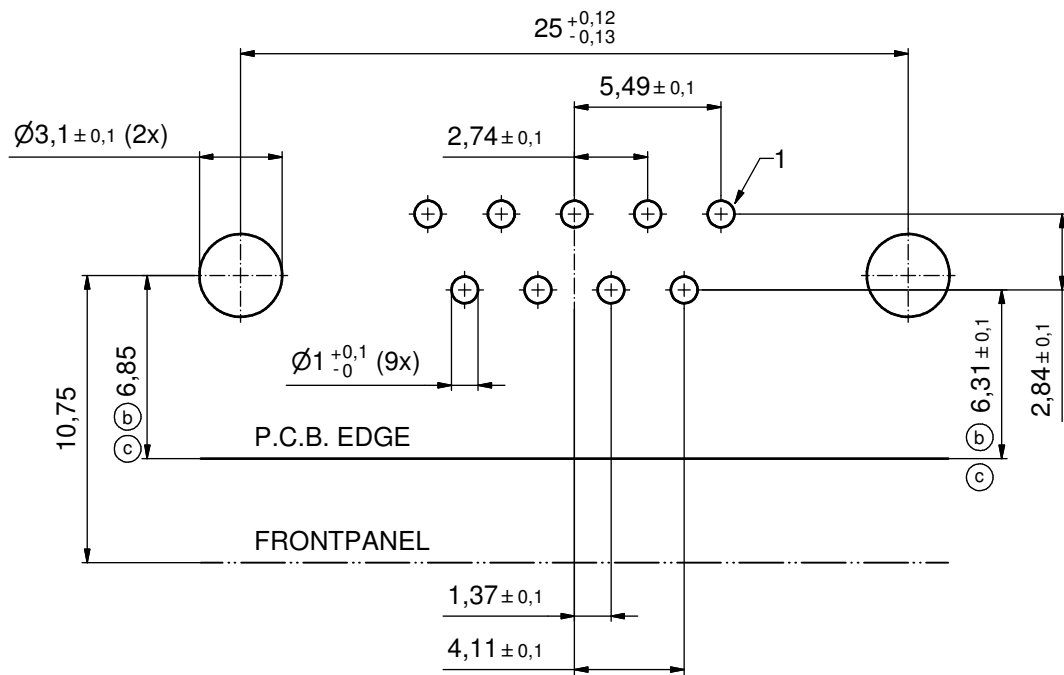

RECOMMENDED PANEL CUT-OUT

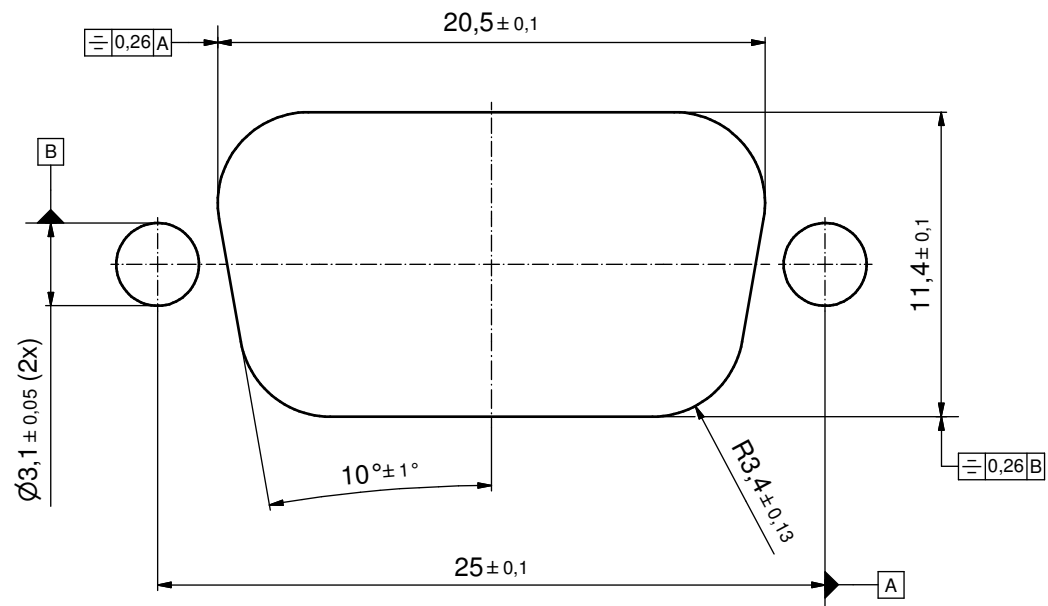

THIS DRAWING MAY NOT BE COPIED OR REPRODUCED IN ANY WAY, AND MAY NOT BE PASSED ON TO A THIRD PARTY WITHOUT WRITTEN PERMISSION. OWNERSHIP AND COPYRIGHT OF CONEC GmbH DO NOT ALTER CAD DRAWING BY HAND					tolerance		scale: 5:1
					date	name	material: see sheet 1
					drawn	17.10.08	Schmidt
					appd.	23.10.08	Fischer
					norm		
2 x c	Ä3435	05.10.09	HS	d-old			title: P.C.B. HOLE DRILLINGS PANEL CUT-OUT D-SUB Female 9pos. Solder pin angled 90°
2 x b	Ä3344	15.04.09	HS			dwg no: 15K1A285	DIN-A3
a	Origin					sh: 2/2	
rev.	description	date	name			part no: SEE SHEET 1	