

1

2

3

4

5

6

A

B

C

D

E

F

A

B

C

D

E

F

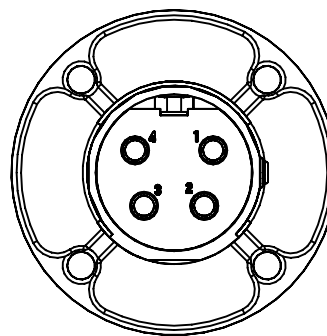
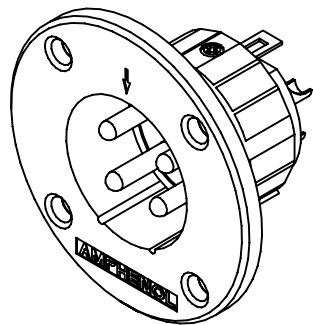

BACK VIEW

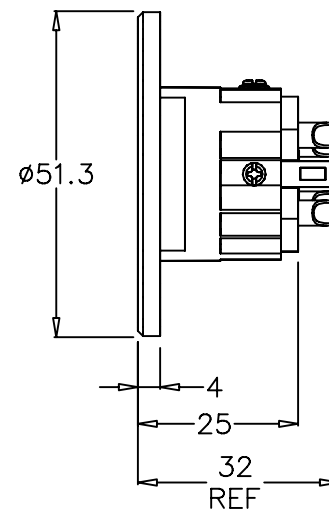

TOP VIEW

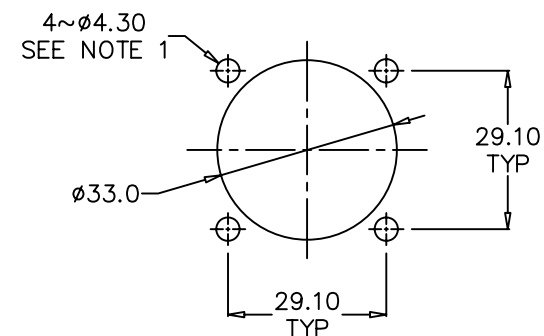
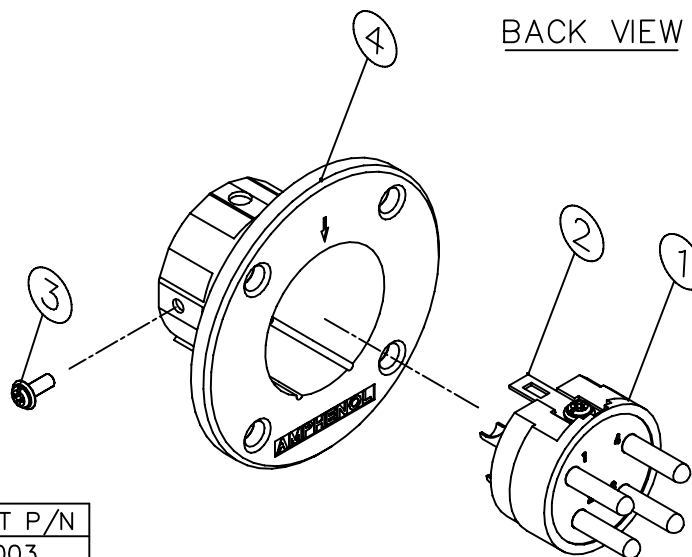
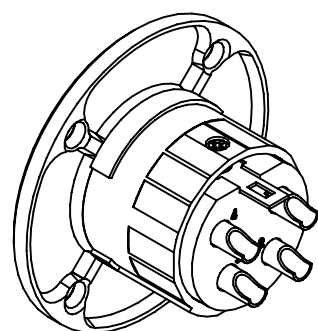

PANEL CUT OUT

EP-* - 14 TYPE	EP/AP INSERT P/N
EP - 3 - 14	156-4402-003
EP - 4 - 14	156-4402-004
EP - 5 - 14	156-4402-005
EP - 6 - 14	156-4402-006
EP - 8 - 14	156-4402-008

NOTE: 1. THE DIAMETER OF THE 4 MOUNTING HOLES ON THE PANEL CUT OUT DEPENDS ON THE SIZE OF THE SCREW TO BE USED
2. FOR EXAMPLE: FOR AN EP-4-14 USE ASSY No. 128037-0004

2	OMIT PART NUMBER EP - 2 - 14 PRODUCT OBSOLETE	M.N.H.	19-11-08	8784
1	UPDATE TO AMPHENOL TITLE BLOCK & LOGO REDRAW, ADD BOM & PANEL CUT OUT	M.N.H.	12-04-01	7784
0	FIRST ISSUE	D.v.E.	15-04-94	----
REV.	CHANGE DETAILS	BY	DATE	CHG/No

ITEM	PART No.	DWG No.	DESCRIPTION	QTY	UNLESS OTHERWISE SPECIFIED TOLERANCE TO BE	THIS DOCUMENT IS THE PROPERTY OF AMPHENOL AUSTRALIA PTY. LTD. NO PART THEREOF MAY BE REPRODUCED AND USED WITHOUT THE PRIOR WRITTEN CONSENT OF THE OWNER	CAD FILE: 00806102	DRN: C.J.W.	DATE: 15-04-94	TITLE: EP-* - 14 CUSTOMER DRAWING	Amphenol	Amphenol Australia Pty Ltd, 2 Fireweys Blvd, Keysborough, Vic 3173	DRAWING NO. 126037-000*	SHEET 1 OF 1
4	248-4099-0**	248-4099-0**	EP-* - 14 SHELL	1	LINEAR: X ± 0.50, X.X ± 0.25, X.XX ± 0.10; ANGULAR: X' ± 1°, X'X' ± 30', X'X'X' ± 15'									
3	990-4500-000	990-4500-000	2-32 PAN WASHER FACE SCREW	2										
2	357-4400-000	357-4400-000	EP RETAINER	1										
1	SEE TABLE	SEE TABLE	EP/AP PIN INSULATOR ASSEMBLY	1										
					DO NOT SCALE	FINISH: REFER TO COMPONENT	APP'D: P.M	DATE: 19-11-08	DATE: 19-11-08					
					DIMENSIONS IN MILLIMETRES	THIRD ANGLE PROJECTION	SCALE: 2:1 UOS	PART No:	SEE TABLE	SIZE: A3				

1

2

3

4

5

6