

FEATURES

- Fast throughput rate: 3 MSPS**
- Wide input bandwidth: 40 MHz**
- No pipeline delays with SAR ADC**
- Excellent dc accuracy performance**
- 2 parallel interface modes**
- Low power: 90 mW (full power) and 2.5 mW (nap mode)**
- Standby mode: 2 μ A maximum**
- Single 5 V supply operation**
- Internal 2.5 V reference**
- Full-scale overrange mode (using 15th bit)**
- System offset removal via user access offset register**
- Nominal 0 V to 2.5 V input with shifted range capability**
- Pin compatible upgrade of 12-bit AD7482**

FUNCTIONAL BLOCK DIAGRAM

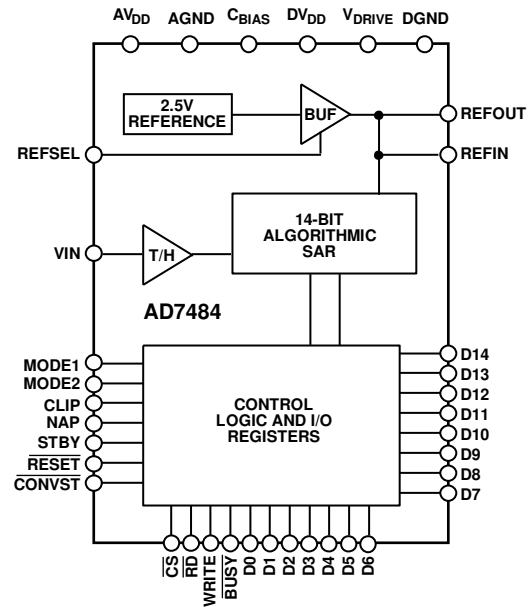

Figure 1.

02642-001

GENERAL DESCRIPTION

The AD7484 is a 14-bit, high speed, low power, successive approximation ADC. The part features a parallel interface with throughput rates up to 3 MSPS. The part contains a low noise, wide bandwidth track-and-hold that can handle input frequencies in excess of 40 MHz.

The conversion process is a proprietary algorithmic successive approximation technique that results in no pipeline delays. The input signal is sampled, and a conversion is initiated on the falling edge of the CONVST signal. The conversion process is controlled by an internally trimmed oscillator. Interfacing is via standard parallel signal lines, making the part directly compatible with microcontrollers and DSPs.

The AD7484 provides excellent ac and dc performance specifications. Factory trimming ensures high dc accuracy, resulting in very low INL, offset, and gain errors.

The part uses advanced design techniques to achieve very low power dissipation at high throughput rates. Power consumption in the normal mode of operation is 90 mW. There are two power saving modes: a nap mode, which keeps the reference circuitry

alive for a quick power-up while consuming 2.5 mW, and a standby mode that reduces power consumption to a mere 10 μ W.

The AD7484 features an on-board 2.5 V reference but can also accommodate an externally provided 2.5 V reference source. The nominal analog input range is 0 V to 2.5 V, but an offset shift capability allows this nominal range to be offset by ± 200 mV. This allows the user considerable flexibility in setting the bottom end reference point of the signal range, a useful feature when using single-supply op amps.

The AD7484 also provides an 8% overrange capability via a 15th bit. Therefore, if the analog input range strays outside the nominal range by up to 8%, the user can still accurately resolve the signal by using the 15th bit.

The AD7484 is powered by a 4.75 V to 5.25 V supply. The part also provides a V_{DRIVE} pin that allows the user to set the voltage levels for the digital interface lines. The range for this V_{DRIVE} pin is 2.7 V to 5.25 V. The part is housed in a 48-lead LQFP package and is specified over a -40°C to $+85^{\circ}\text{C}$ temperature range.

Rev. C

Information furnished by Analog Devices is believed to be accurate and reliable. However, no responsibility is assumed by Analog Devices for its use, nor for any infringements of patents or other rights of third parties that may result from its use. Specifications subject to change without notice. No license is granted by implication or otherwise under any patent or patent rights of Analog Devices. Trademarks and registered trademarks are the property of their respective owners.

TABLE OF CONTENTS

Features 1
 Functional Block Diagram 1
 General Description 1
 Revision History 2
 Specifications..... 3
 Timing Characteristics 5
 Absolute Maximum Ratings..... 6
 ESD Caution..... 6
 Pin Configuration and Function Descriptions..... 7
 Typical Performance Characteristics 9
 Terminology 11

Circuit Description..... 12
 Converter Operation..... 12
 Analog Input 12
 ADC Transfer Function..... 13
 Power Saving..... 13
 Offset/Ovrange..... 14
 Parallel Interface..... 15
 Board Layout and Grounding..... 17
 Outline Dimensions 19
 Ordering Guide 19

REVISION HISTORY

12/09—Rev. B to Rev. C

Changes to Table 1, Power Requirements Section 4
 Changes to Ordering Guide 19

8/08—Rev. A. to Rev. B

Changes to Table 1 3
 Changes to Table 3 6
 Changes to Typical Performance Characteristics Section..... 9
 Changes to Figure 9..... 10
 Changes to Circuit Description Section 11
 Changes to Terminology Section..... 11
 Changes to Analog Input Section..... 12
 Changes to Offset/Ovrange Section 14
 Changes to Table 5, Table 6, Table 7, and Table 8..... 15
 Changes to Parallel Interface Section..... 15
 Changes to Table 9..... 16
 Changes to Board Layout and Grounding Section 17
 Changes to Ordering Guide 19

2/04—Rev. 0 to Rev. A

Updated Format..... Universal
 Changes to Timing Characteristics Section 5
 Changes to Pin Function Descriptions Section..... 8
 Changes to Figure 9..... 11
 Changes to the Converter Operation Section..... 13
 Changes to the Offset/Ovrange Section..... 15

8/02—Revision 0: Initial Version

SPECIFICATIONS

$V_{DD}/DV_{DD} = 5 V \pm 5\%$, $AGND = DGND = 0 V$, $V_{REF} = \text{external}$, $f_{\text{SAMPLE}} = 3 \text{ MSPS}$; all specifications T_{MIN} to T_{MAX} and valid for $V_{\text{DRIVE}} = 2.7 V$ to $5.25 V$, unless otherwise noted. Operating temperature range is -40°C to $+85^{\circ}\text{C}$.

Table 1.

Parameter	Min	Typ	Max	Unit	Test Conditions/Comments
DYNAMIC PERFORMANCE^{1, 2}					
Signal-to-Noise + Distortion (SINAD) ³	76.5			dB	$f_{\text{IN}} = 1 \text{ MHz}$
		78		dB	$f_{\text{IN}} = 1 \text{ MHz}$
		79		dB	$f_{\text{IN}} = 1 \text{ MHz}$, extended input
		77		dB	$f_{\text{IN}} = 1 \text{ MHz}$, internal reference
Total Harmonic Distortion (THD) ³			-90	dB	
		-95		dB	
		-92		dB	Internal reference
Peak Harmonic or Spurious Noise (SFDR) ³			-90	dB	
Intermodulation Distortion (IMD) ³					
Second Order Terms		-96		dB	$f_{\text{IN1}} = 95.053 \text{ kHz}$, $f_{\text{IN2}} = 105.329 \text{ kHz}$
Third Order Terms		-94		dB	
Aperture Delay		10		ns	
Full Power Bandwidth		40		MHz	@ 3 dB
		3.5		MHz	@ 0.1 dB
DC ACCURACY					
Resolution	14			Bits	
Integral Nonlinearity ³		± 0.5	± 1	LSB	Guaranteed no missed codes to 14 bits
Differential Nonlinearity ³		± 0.3	± 0.75	LSB	
Offset Error ³			± 6	LSB	
			0.036	%FSR	
Gain Error ³			± 6	LSB	
			0.036	%FSR	
ANALOG INPUT					
Input Voltage	-200		+2.7	mV V	V_{IN} from 0 V to 2.7 V $V_{\text{IN}} = -200 \text{ mV}$
DC Leakage Current			± 1	μA	
		± 2		μA	
Input Capacitance ⁴		35		pF	
REFERENCE INPUT/OUTPUT					
Input Voltage, V_{REFIN}		+2.5		V	$\pm 1\%$ for specified performance
Input DC Leakage Current, V_{REFIN}			± 1	μA	External reference
Input Capacitance, V_{REFIN} ⁴		25		pF	
Input Current, V_{REFIN}		220		μA	
Output Voltage, V_{REFOUT}		+2.5		V	
Error @ 25°C , V_{REFOUT}		± 50		mV	
Error T_{MIN} to T_{MAX} , V_{REFOUT}			± 100	mV	
Output Impedance, V_{REFOUT}		1		Ω	

AD7484

Parameter	Min	Typ	Max	Unit	Test Conditions/Comments
LOGIC INPUTS					
Input High Voltage, V_{INH}	$V_{DRIVE} - 1$			V	
Input Low Voltage, V_{INL}			0.4	V	
Input Current, I_{IN}			± 1	μA	
Input Capacitance, C_{IN}^4			10	pF	
LOGIC OUTPUTS					
Output High Voltage, V_{OH}	$0.7 \times V_{DRIVE}$			V	
Output Low Voltage, V_{OL}			0.4	V	
Floating State Leakage Current			± 10	μA	
Floating State Output Capacitance ⁴			10	pF	
Output Coding	Straight (Natural) Binary				
CONVERSION RATE					
Conversion Time			300	ns	
Track-and-Hold Acquisition Time (t_{ACQ})			70	ns	Sine wave input
			70	ns	Full-scale step input
Throughput Rate			2.5	MSPS	Parallel Mode 1
			3	MSPS	Parallel Mode 2
POWER REQUIREMENTS					
V_{DD}		5		V	$\pm 5\%$
V_{DRIVE}	2.7		5.25	V	
I_{DD}					
Normal Mode (Static)			13	mA	\overline{CS} and $\overline{RD} = \text{Logic 1}$
Normal Mode (Operational)			20	mA	
Nap Mode			0.5	mA	
Standby Mode		0.5	2	μA	
Power Dissipation					
Normal Mode (Operational)			100	mW	
Nap Mode			2.5	mW	
Standby Mode ⁵			10	μW	

¹ SINAD figures quoted include external analog input circuit noise contribution of approximately 1 dB.

² See the Typical Performance Characteristics section for analog input circuits used.

³ See the Terminology section.

⁴ Sample tested @ 25°C to ensure compliance.

⁵ Digital input levels at DGND or V_{DRIVE} .

TIMING CHARACTERISTICS

$V_{DD}/DV_{DD} = 5\text{ V} \pm 5\%$, $AGND = DGND = 0\text{ V}$, $V_{REF} = \text{external}$; all specifications T_{MIN} to T_{MAX} and valid for $V_{DRIVE} = 2.7\text{ V}$ to 5.25 V , unless otherwise noted.

Table 2.

Parameter ¹	Symbol	Min	Typ	Max	Unit
DATA READ					
Conversion Time	t_{CONV}			300	ns
Quiet Time Before Conversion Start	t_{QUIET}	100			ns
\overline{CONVST} Pulse Width	t_1	5		100	ns
\overline{CONVST} Falling Edge to \overline{BUSY} Falling Edge	t_2			20	ns
\overline{CS} Falling Edge to \overline{RD} Falling Edge	t_3	0			ns
Data Access Time	t_4			25	ns
\overline{CONVST} Falling Edge to New Data Valid	t_5			30	ns
\overline{BUSY} Rising Edge to New Data Valid	t_6			5	ns
Bus Relinquish Time	t_7		10		ns
\overline{RD} Rising Edge to \overline{CS} Rising Edge	t_8	0			ns
\overline{CS} Pulse Width	t_{14}	30			ns
\overline{RD} Pulse Width	t_{15}	30			ns
DATA WRITE					
WRITE Pulse Width	t_9	5			ns
Data Setup Time	t_{10}	2			ns
Data Hold Time	t_{11}	6			ns
\overline{CS} Falling Edge to WRITE Falling Edge	t_{12}	5			ns
WRITE Falling Edge to \overline{CS} Rising Edge	t_{13}	0			ns

¹All timing specifications given are with a 25 pF load capacitance. With a load capacitance greater than this value, a digital buffer or latch must be used.

ABSOLUTE MAXIMUM RATINGS

$T_A = 25^\circ\text{C}$, unless otherwise noted.

Table 3.

Parameter	Rating
AV_{DD} to AGND	-0.3 V to +7 V
DV_{DD} to DGND	-0.3 V to +7 V
V_{DRIVE} to DGND	-0.3 V to +7 V
Analog Input Voltage to AGND	-0.3 V to $AV_{DD} + 0.3$ V
Digital Input Voltage to DGND	-0.3 V to $V_{DRIVE} + 0.3$ V
REFIN to AGND	-0.3 V to $AV_{DD} + 0.3$ V
Input Current to Any Pin Except Supply Pins	± 10 mA
Operating Temperature Range Commercial	-40°C to $+85^\circ\text{C}$
Storage Temperature Range	-65°C to $+150^\circ\text{C}$
Junction Temperature	150°C
θ_{JA} Thermal Impedance	$50^\circ\text{C}/\text{W}$
θ_{JC} Thermal Impedance	$10^\circ\text{C}/\text{W}$
Lead Temperature, Soldering	
Vapor Phase (60 sec)	215°C
Infrared (15 sec)	220°C
ESD	1 kV

Stresses above those listed under Absolute Maximum Ratings may cause permanent damage to the device. This is a stress rating only; functional operation of the device at these or any other conditions above those indicated in the operational section of this specification is not implied. Exposure to absolute maximum rating conditions for extended periods may affect device reliability.

ESD CAUTION



ESD (electrostatic discharge) sensitive device. Charged devices and circuit boards can discharge without detection. Although this product features patented or proprietary protection circuitry, damage may occur on devices subjected to high energy ESD. Therefore, proper ESD precautions should be taken to avoid performance degradation or loss of functionality.

PIN CONFIGURATION AND FUNCTION DESCRIPTIONS

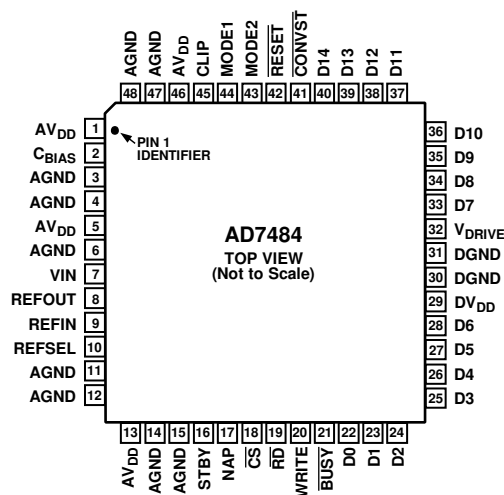

Figure 2. Pin Configuration

Table 4. Pin Function Descriptions

Pin No.	Mnemonic	Description
1, 5, 13, 46	AV _{DD}	Positive Power Supply for Analog Circuitry.
2	C _{BIAS}	Decoupling Pin for Internal Bias Voltage. A 1 nF capacitor should be placed between this pin and AGND.
3, 4, 6, 11, 12, 14, 15, 47, 48	AGND	Power Supply Ground for Analog Circuitry.
7	VIN	Analog Input. Single ended analog input channel.
8	REFOUT	Reference Output. REFOUT connects to the output of the internal 2.5 V reference buffer. A 470 nF capacitor must be placed between this pin and AGND.
9	REFIN	Reference Input. A 470 nF capacitor must be placed between this pin and AGND. When using an external voltage reference source, the reference voltage should be applied to this pin.
10	REFSEL	Reference Decoupling Pin. When using the internal reference, a 1 nF capacitor must be connected from this pin to AGND. When using an external reference source, this pin should be connected directly to AGND.
16	STBY	Standby Logic Input. When this pin is logic high, the device is placed in standby mode. See the Power Saving section for further details.
17	NAP	Nap Logic Input. When this pin is logic high, the device is placed in a very low power mode. See the Power Saving section for further details.
18	\overline{CS}	Chip Select Logic Input. This pin is used in conjunction with \overline{RD} to access the conversion result. The data bus is brought out of three-state and the current contents of the output register driven onto the data lines following the falling edge of both \overline{CS} and \overline{RD} . \overline{CS} is also used in conjunction with WRITE to perform a write to the offset register. \overline{CS} can be hardwired permanently low.
19	\overline{RD}	Read Logic Input. Used in conjunction with \overline{CS} to access the conversion result.
20	WRITE	Write Logic Input. Used in conjunction with \overline{CS} to write data to the offset register. When the desired offset word has been placed on the data bus, the WRITE line should be pulsed high. It is the falling edge of this pulse that latches the word into the offset register.
21	\overline{BUSY}	Busy Logic Output. This pin indicates the status of the conversion process. The \overline{BUSY} signal goes low after the falling edge of \overline{CONVST} and stays low for the duration of the conversion. In Parallel Mode 1, the \overline{BUSY} signal returns high when the conversion result has been latched into the output register. In Parallel Mode 2, the \overline{BUSY} signal returns high as soon as the conversion has been completed, but the conversion result does not get latched into the output register until the falling edge of the next \overline{CONVST} pulse.
22 to 28, 33 to 39	D0 to D13	Data I/O Bits. D13 is MSB. These are three-state pins that are controlled by \overline{CS} , \overline{RD} , and WRITE. The operating voltage level for these pins is determined by the V _{DRIVE} input.
29	DV _{DD}	Positive Power Supply for Digital Circuitry.
30, 31	DGND	Ground Reference for Digital Circuitry.
32	V _{DRIVE}	Logic Power Supply Input. The voltage supplied at this pin determines at what voltage the interface logic of the device operates.

AD7484

Pin No.	Mnemonic	Description
40	D14	Data Output Bit for Overranging. If the overrange feature is not used, this pin should be pulled to DGND via a 100 k Ω resistor.
41	$\overline{\text{CONVST}}$	Convert Start Logic Input. A conversion is initiated on the falling edge of the $\overline{\text{CONVST}}$ signal. The input track-and-hold amplifier goes from track mode to hold mode, and the conversion process commences.
42	$\overline{\text{RESET}}$	Reset Logic Input. An active low reset pulse must be applied to this pin after power-up to ensure correct operation. A falling edge on this pin resets the internal state machine and terminates a conversion that may be in progress. The contents of the offset register will also be cleared on this edge. Holding this pin low keeps the part in a reset state.
43	MODE2	Operating Mode Logic Input. See Table 8 for details.
44	MODE1	Operating Mode Logic Input. See Table 8 for details.
45	CLIP	Logic Input. A logic high on this pin enables output clipping. In this mode, any input voltage that is greater than positive full scale or less than negative full scale will be clipped to all 1s or all 0s, respectively. Further details are given in the Offset/Overage section.

TYPICAL PERFORMANCE CHARACTERISTICS

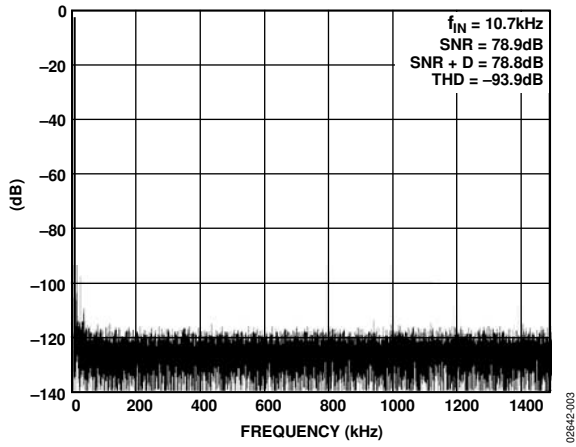

Figure 3. 64 k FFT Plot with 10 kHz Input Tone

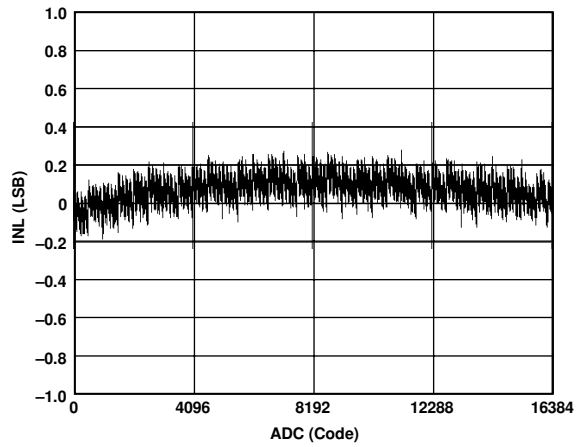

Figure 6. Typical INL

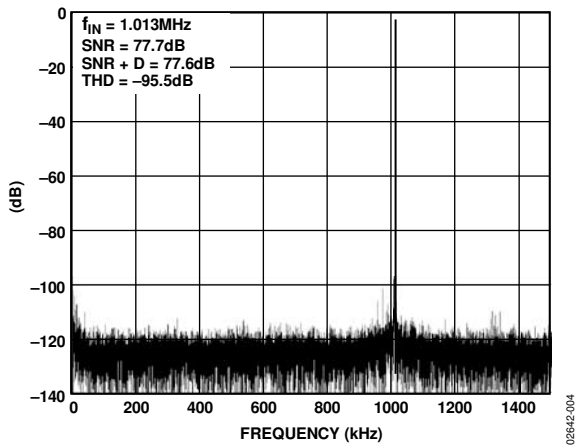

Figure 4. 64 k FFT Plot with 1 MHz Input Tone

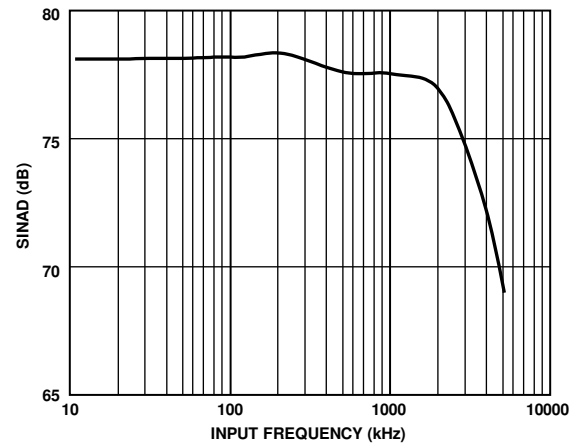

Figure 7. SINAD vs. Input Tone (AD8021 Input Circuit)

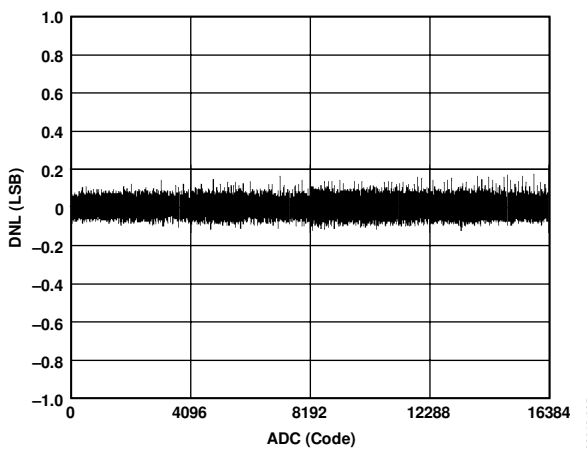

Figure 5. Typical DNL

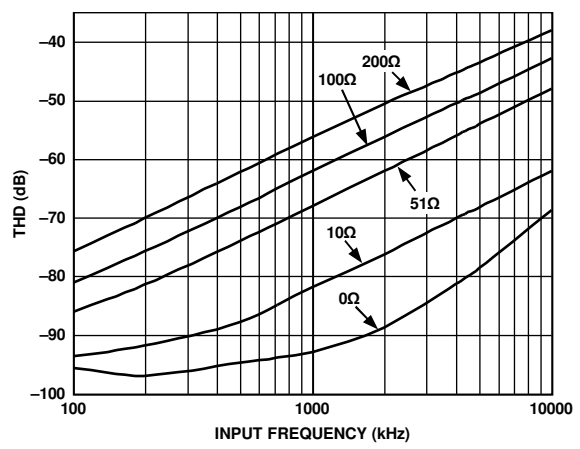

Figure 8. THD vs. Input Tone for Different Input Resistances

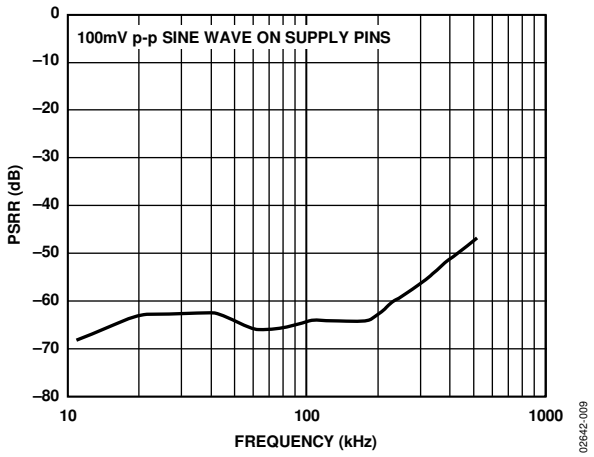

Figure 9. PSRR Without Decoupling

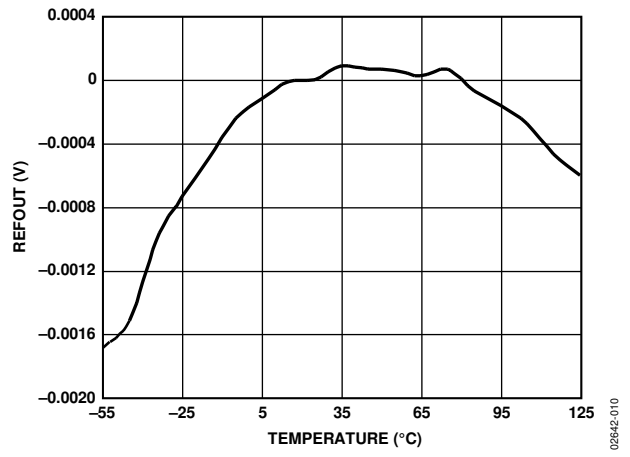

Figure 10. Reference Error

TERMINOLOGY

Integral Nonlinearity

The integral nonlinearity is the maximum deviation from a straight line passing through the endpoints of the ADC transfer function. The endpoints of the transfer function are zero scale, a point 1/2 LSB below the first code transition, and full scale, a point 1/2 LSB above the last code transition.

Differential Nonlinearity

The differential nonlinearity is the difference between the measured and ideal 1 LSB change between any two adjacent codes in the ADC.

Offset Error

The offset error is the deviation of the first code transition (00...000) to (00...001) from the ideal, that is, AGND + 0.5 LSB.

Gain Error

The gain error is the deviation of the last code transition (111...110) to (111...111) from the ideal, that is, $V_{REF} - 1.5$ LSB, after the offset error has been adjusted out.

Track-and-Hold Acquisition Time

The track-and-hold acquisition time is the time required for the output of the track-and-hold amplifier to reach its final value, within $\pm 1/2$ LSB, after the end of conversion (the point at which the track-and-hold returns to track mode).

Signal-to-Noise + Distortion (SINAD) Ratio

The SINAD ratio is the measured ratio of signal-to-noise + distortion at the output of the ADC. The signal is the rms amplitude of the fundamental. Noise is the sum of all nonfundamental signals up to half the sampling frequency ($f_s/2$), excluding dc. The ratio is dependent on the number of quantization levels in the digitization process; the more levels, the smaller the quantization noise. The theoretical SINAD ratio for an ideal N-bit converter with a sine wave input is given by

$$\text{Signal-to-Noise + Distortion} = (6.02N + 1.76)\text{dB}$$

Therefore, this is 86.04 dB for a 14-bit converter.

Total Harmonic Distortion (THD)

The THD is the ratio of the rms sum of the harmonics to the fundamental. It is defined as

$$\text{THD (dB)} = 20 \log \frac{\sqrt{V_2^2 + V_3^2 + V_4^2 + V_5^2 + V_6^2}}{V_1}$$

where V_1 is the rms amplitude of the fundamental and V_2 , V_3 , V_4 , V_5 , and V_6 are the rms amplitudes of the second through the sixth harmonics.

Peak Harmonic or Spurious Noise

The peak harmonic or spurious noise is the ratio of the rms value of the next largest component in the ADC output spectrum (up to $f_s/2$ and excluding dc) to the rms value of the fundamental. The value of this specification is usually determined by the largest harmonic in the spectrum, but for ADCs where the harmonics are buried in the noise floor, it is a noise peak.

Intermodulation Distortion

With inputs consisting of sine waves at two frequencies, f_a and f_b , any active device with nonlinearities creates distortion products at sum and difference frequencies of $m f_a \pm n f_b$, where m and $n = 0, 1, 2, 3$, and so on. Intermodulation distortion terms are those for which neither m nor n is equal to zero. For example, the second order terms include $(f_a + f_b)$ and $(f_a - f_b)$, whereas the third order terms include $(2f_a + f_b)$, $(2f_a - f_b)$, $(f_a + 2f_b)$, and $(f_a - 2f_b)$.

The AD7484 is tested using the CCIF standard where two input frequencies near the top end of the input bandwidth are used. In this case, the second order terms are usually distanced in frequency from the original sine waves, whereas the third order terms are usually at a frequency close to the input frequencies. As a result, the second order and third order terms are specified separately. The calculation of the intermodulation distortion is as per the THD specification, where it is the ratio of the rms sum of the individual distortion products to the rms amplitude of the sum of the fundamentals expressed in dBs.

CIRCUIT DESCRIPTION

CONVERTER OPERATION

The AD7484 is a 14-bit algorithmic successive approximation ADC based around a capacitive DAC. It provides the user with track-and-hold, reference, an ADC, and versatile interface logic functions on a single chip. The normal analog input signal range that the AD7484 can convert is 0 V to 2.5 V. By using the offset and overrange features on the ADC, the AD7484 can convert analog input signals from -200 mV to +2.7 V while operating from a single 5 V supply. The part requires a 2.5 V reference, which can be provided from the internal reference or an external reference source. Figure 11 shows a simplified schematic of the ADC. The control logic, SAR, and capacitive DAC are used to add and subtract fixed amounts of charge from the sampling capacitor to bring the comparator back to a balanced condition.

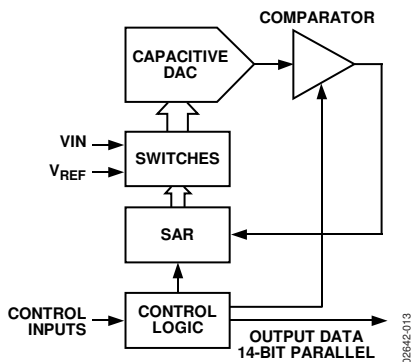

Figure 11. Simplified Block Diagram of the AD7484

Conversion is initiated on the AD7484 by pulsing the CONVST input. On the falling edge of CONVST, the track-and-hold goes from track mode to hold mode and the conversion sequence is started. Conversion time for the part is 300 ns. Figure 12 shows the ADC during conversion. When conversion starts, SW2 opens and SW1 moves to Position B, causing the comparator to become unbalanced. The ADC then runs through its successive-approximation routine and brings the comparator back into a balanced condition. When the comparator is rebalanced, the conversion result is available in the SAR register.

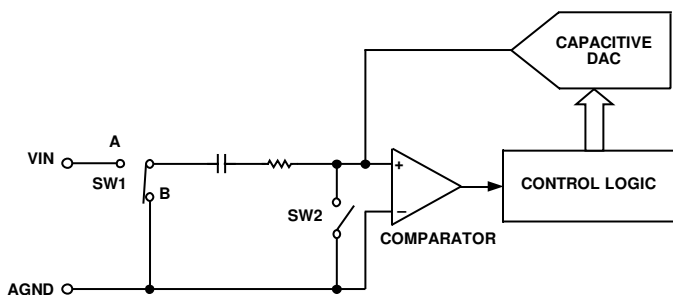

Figure 12. ADC Conversion Phase

At the end of conversion, the track-and-hold returns to track mode and the acquisition time begins. The track-and-hold acquisition time is 70 ns. Figure 13 shows the ADC during its acquisition phase. SW2 is closed and SW1 is in Position A. The comparator is held in a balanced condition, and the sampling capacitor acquires the signal on VIN.

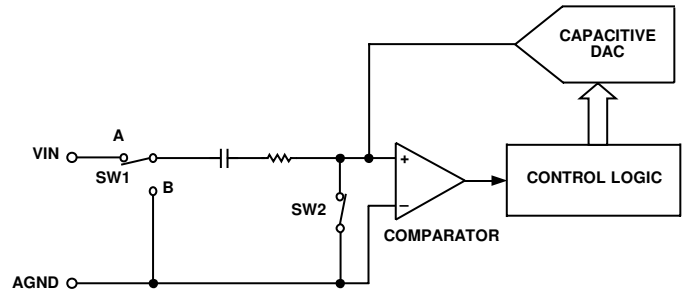

Figure 13. ADC Acquisition Phase

ANALOG INPUT

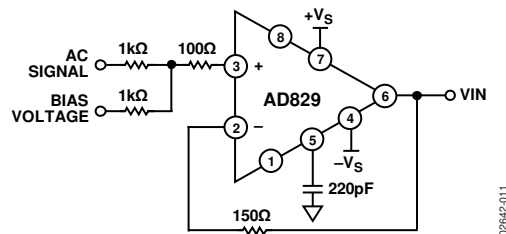

Figure 14. Analog Input Circuit Used for 10 kHz Input Tone

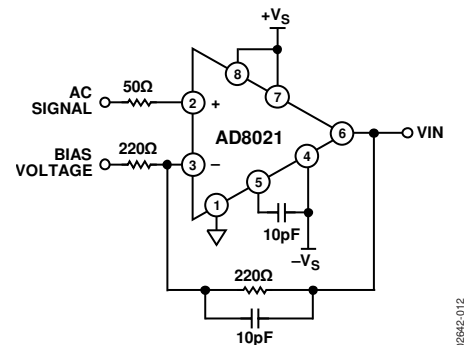

Figure 15. Analog Input Circuit Used for 1 MHz Input Tone

Figure 14 shows the analog input circuit used to obtain the data for the fast fourier transfer (FFT) plot shown in Figure 3. The circuit uses the AD829 op amp as the input buffer. A bipolar analog signal is applied and biased up with a stable, low noise dc voltage connected to the labeled terminal, as shown in Figure 11. A 220 pF compensation capacitor is connected between Pin 5 of the AD829 and the analog ground plane. The AD829 is supplied with +12 V and -12 V supplies. The supply pins are decoupled as close to the device as possible with both a 0.1 μF and a 10 μF capacitor connected to each pin. In each case, the 0.1 μF capacitor should be the closer of the two caps to the device. More information on the AD829 is available at www.analog.com.

For higher input bandwidth applications, the [AD8021](#) op amp (also available as a dual [AD8022](#) op amp) is the recommended choice to drive the AD7484. Figure 15 shows the analog input circuit used to obtain the data for the FFT plot shown in Figure 4. A bipolar analog signal is applied to the terminal and biased up with a stable, low noise dc voltage connected, as shown in Figure 12. A 10 pF compensation capacitor is connected between Pin 5 of the AD8021 and the negative supply. The AD8021 is supplied with +12 V and -12 V supplies. The supply pins are decoupled as close to the device as possible, with both a 0.1 μ F and a 10 μ F capacitor connected to each pin. In each case, the 0.1 μ F capacitor should be the closer of the two caps to the device. The AD8021 logic reference pin is tied to analog ground, and the DISABLE pin is tied to the positive supply. Detailed information on the AD8021 is available at www.analog.com.

ADC TRANSFER FUNCTION

The output coding of the AD7484 is straight binary. The designed code transitions occur midway between the successive integer LSB values, that is, 1/2 LSB, 3/2 LSB, and so on. The LSB size is $V_{REF}/16,384$. The nominal transfer characteristic for the AD7484 is shown in Figure 16. This transfer characteristic may be shifted as detailed in the Offset/Ovrrange section.

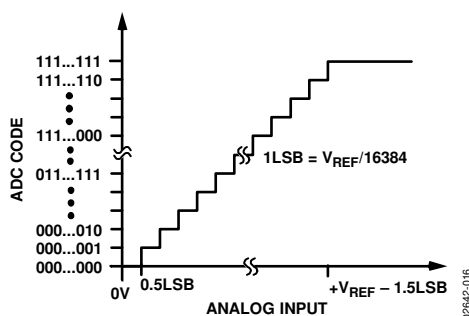

Figure 16. AD7484 Transfer Characteristic

POWER SAVING

The AD7484 uses advanced design techniques to achieve very low power dissipation at high throughput rates. In addition, the AD7484 features two power saving modes, nap and standby. These modes are selected by bringing either the NAP pin or the STBY pin to a logic high, respectively.

When operating the AD7484 in normal fully powered mode, the current consumption is 18 mA during conversion and the quiescent current is 12 mA. Operating at a throughput rate of 1 MSPS, the conversion time of 300 ns contributes 27 mW to the overall power dissipation.

$$(300 \text{ ns}/1 \mu\text{s}) \times (5 \text{ V} \times 18 \text{ mA}) = 27 \text{ mW}$$

For the remaining 700 ns of the cycle, the AD7484 dissipates 42 mW of power.

$$(700 \text{ ns}/1 \mu\text{s}) \times (5 \text{ V} \times 12 \text{ mA}) = 42 \text{ mW}$$

Therefore, the power dissipated during each cycle is

$$27 \text{ mW} + 42 \text{ mW} = 69 \text{ mW}$$

Figure 17 shows the AD7484 conversion sequence operating in normal mode.

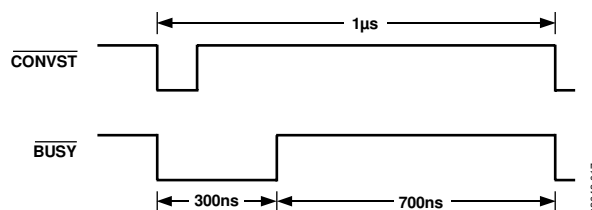

Figure 17. Normal Mode Power Dissipation

In nap mode, almost all of the internal circuitry is powered down. In this mode, the power dissipation is reduced to 2.5 mW. When using an external reference, there must be a minimum of 300 ns from exiting nap mode to initiating a conversion. This is necessary to allow the internal circuitry to settle after power-up and for the track-and-hold to properly acquire the analog input signal. The internal reference cannot be used in conjunction with the nap mode.

If the AD7484 is put into nap mode after each conversion, the average power dissipation is reduced, but the throughput rate is limited by the power-up time. Using the AD7484 with a throughput rate of 500 kSPS while placing the part in nap mode after each conversion results in average power dissipation as follows:

The power-up phase contributes

$$(300 \text{ ns}/2 \mu\text{s}) \times (5 \text{ V} \times 12 \text{ mA}) = 9 \text{ mW}$$

The conversion phase contributes

$$(300 \text{ ns}/2 \mu\text{s}) \times (5 \text{ V} \times 18 \text{ mA}) = 13.5 \text{ mW}$$

While in nap mode for the rest of the cycle, the AD7484 dissipates only 1.75 mW of power.

$$(1400 \text{ ns}/2 \mu\text{s}) \times (5 \text{ V} \times 0.5 \text{ mA}) = 1.75 \text{ mW}$$

Therefore, the power dissipated during each cycle is

$$9 \text{ mW} + 13.5 \text{ mW} + 1.75 \text{ mW} = 24.25 \text{ mW}$$

Figure 18 shows the AD7484 conversion sequence when the part is put into nap mode after each conversion.

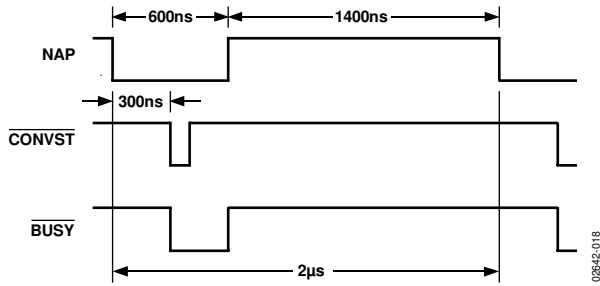

Figure 18. Nap Mode Power Dissipation

Figure 19 and Figure 20 show a typical graphical representation of power vs. throughput for the AD7484 when in normal mode and nap mode, respectively.

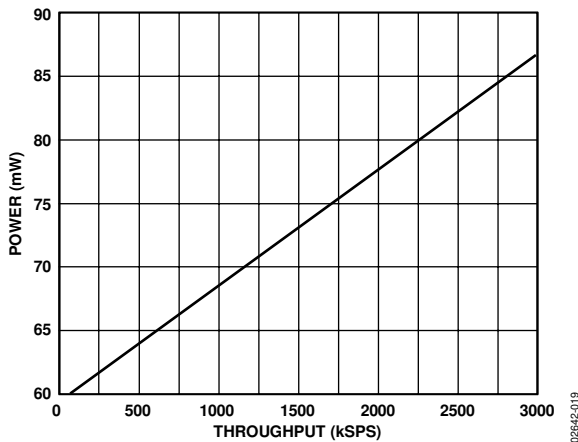

Figure 19. Normal Mode, Power vs. Throughput

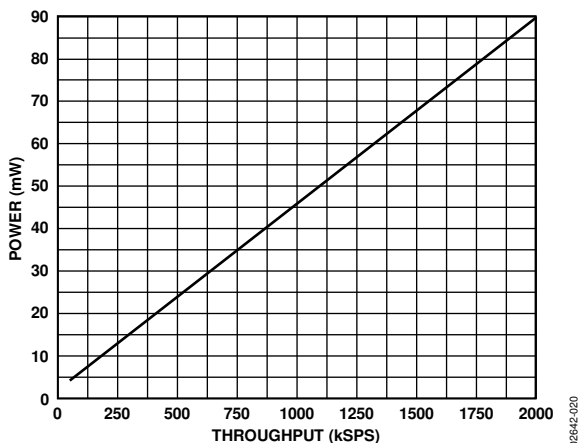

Figure 20. Nap Mode, Power vs. Throughput

In standby mode, all internal circuitry is powered down and the power consumption of the AD7484 is reduced to 10 μ W. The power-up time necessary before a conversion can be initiated is longer because more of the internal circuitry has been powered down. In using the internal reference of the AD7484, the ADC must be brought out of standby mode 500 ms before a conversion is initiated. Initiating a conversion before the required power-up time has elapsed results in incorrect conversion data. If an external

reference source is used and kept powered up while the AD7484 is in standby mode, the power-up time required is reduced to 80 μ s.

OFFSET/OVERRANGE

The AD7484 provides a $\pm 8\%$ overrange capability as well as a programmable offset register. The overrange capability is achieved by the use of a 15th bit (D14) and the CLIP input. If the CLIP input is at logic high and the contents of the offset register are 0, then the AD7484 operates as a normal 14-bit ADC. If the input voltage is greater than the full-scale voltage, the data output from the ADC is all 1s. Similarly, if the input voltage is lower than the zero-scale voltage, the data output from the ADC is all 0s. In this case, D14 acts as an overrange indicator. It is set to 1 if the analog input voltage is outside the nominal 0 V to 2.5 V range.

The default contents of the offset register are 0. If the offset register contains any value other than 0, the contents of the register are added to the SAR result at the end of conversion. This has the effect of shifting the transfer function of the ADC as shown in Figure 21 and Figure 22. However, it should be noted that with the CLIP input set to logic high, the maximum and minimum codes that the AD7484 can output are 0x3FFF and 0x0000, respectively. Further details are given in Table 5 and Table 6.

Figure 21 shows the effect of writing a positive value to the offset register. For example, if the contents of the offset register contained the value 1024, then the value of the analog input voltage for which the ADC transitions from reading all 0s to 000...001 (the bottom reference point) is

$$0.5 \text{ LSB} - (1024 \text{ LSB}) = -156.326 \text{ mV}$$

The analog input voltage for which the ADC reads full-scale (0x3FFF) in this example is

$$2.5 - 1.5 \text{ LSB} - (1024 \text{ LSB}) = 2.34352 \text{ V}$$

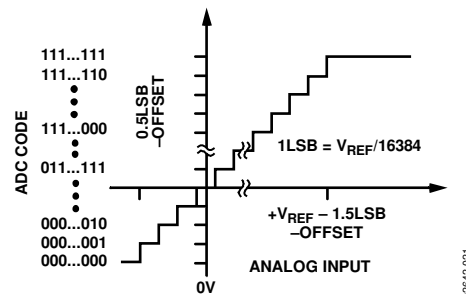

Figure 21. Transfer Characteristic with Positive Offset

The effect of writing a negative value to the offset register is shown in Figure 22. If a value of -512 is written to the offset register, the bottom end reference point occurs at

$$0.5 \text{ LSB} - (-512 \text{ LSB}) = 78.20 \text{ mV}$$

Following this, the analog input voltage needed to produce a full-scale (0x3FFF) result from the ADC is

$$2.5 \text{ V} - 1.5 \text{ LSB} - (-512 \text{ LSB}) = 2.5779 \text{ V}$$

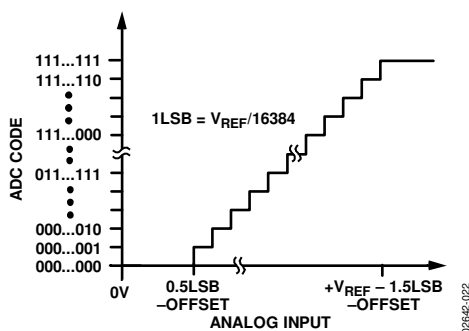

Figure 22. Transfer Characteristic with Negative Offset

Table 5 shows the expected ADC result for a given analog input voltage with different offset values and with CLIP tied to logic high. The combined advantages of the offset and overrange features of the AD7484 are shown in Table 6. Table 6 shows the same range of analog input and offset values as Table 5 but with the clipping feature disabled.

Table 5. Clipping Enabled (CLIP = 1)

Offset VIN	ADC DATA, D[0:13]			D14
	-512	0	+1024	
-200 mV	0	0	0	1 1 1
-156.3 mV	0	0	0	1 1 0
0V	0	0	1024	1 0 0
+78.2 mV	0	512	1536	0 0 0
+2.3434 V	14,846	15,358	16,383	0 0 0
+2.5 V	15,871	16,383	16,383	0 0 1
+2.5782 V	16,383	16,383	16,383	0 1 1
+2.7 V	16,383	16,383	16,383	1 1 1

Table 6. Clipping Disabled (CLIP = 0)

Offset VIN	ADC DATA, D[0:14]		
	-512	0	+1024
-200 mV	-1823	-1311	-287
-156.3 mV	-1536	-1024	0
0V	-512	0	1024
+78.2 mV	0	512	1536
+2.3434 V	14,846	15,358	16,382
+2.5 V	15,872	16,384	17,408
+2.5782 V	16,384	16,896	17,920
+2.7 V	17,183	17,695	18,719

If the CLIP input is at logic low, the overrange indicator is disabled and the AD7484 can achieve output codes outside the nominal 14-bit range of 0 to 16,383 (see Table 6). D14 acts as an indicator that the ADC is outside this nominal range. If the ADC is outside this nominal range on the negative side, the ADC outputs a twos complement code and if the ADC is outside the range on the positive side, the ADC outputs a straight binary code as normal. If D14 is Logic 1, D13 indicates if the ADC is out of range on the positive or negative side. If DB13 is Logic 1, the ADC is outside the nominal range on the negative side and the output code is a 15-bit twos complement number (a negative number). If D13 is Logic 0, the ADC is outside the nominal

range on the positive side and the output code is a 15-bit straight binary code (see Table 7).

Table 7. DB14, DB13 Decoding, CLIP = 0

DB14	DB13	Output Coding
0	0	Straight binary—inside nominal range
0	1	Straight binary—inside nominal range
1	0	Straight binary—outside nominal range
1	1	Twos complement—outside nominal range

Values from -1310 to +130 can be written to the offset register. These values correspond to an offset of ± 200 mV. A write to the offset register is performed by writing a 13-bit word to the part, as detailed in the Parallel Interface section. The 12 LSBs of the 15-bit word contain the offset value, whereas the 3 MSBs must be set to 0. Failure to write 0s to the 3 MSBs may result in the incorrect operation of the device.

PARALLEL INTERFACE

The AD7484 features two parallel interfacing modes. These modes are selected by the mode pins (see Table 8).

Table 8. Operating Modes

Operating Mode	Mode 2	Mode 1
Do Not Use	0	0
Parallel Mode 1	0	1
Parallel Mode 2	1	0
Do Not Use	1	1

In Parallel Mode 1, the data in the output register is updated on the rising edge of BUSY at the end of a conversion and is available for reading almost immediately afterwards. Using this mode, throughput rates of up to 2.5 MSPS can be achieved. This mode is to be used if the conversion data is required immediately after the conversion is completed. An example where this may be of use is if the AD7484 is operating at much lower throughput rates in conjunction with the nap mode (for power saving reasons), and the input signal is being compared with set limits within the DSP or other controller. If the limits are exceeded, the ADC is brought immediately into full power operation and commences sampling at full speed. Figure 31 shows a timing diagram for the AD7484 operating in Parallel Mode 1 with both $\overline{\text{CS}}$ and $\overline{\text{RD}}$ tied low.

In Parallel Mode 2, the data in the output register is not updated until the next falling edge of CONVST. This mode can be used where a single sample delay is not vital to the system operation, and conversion speeds of greater than 2.5 MSPS are desired. For example, this may occur in a system where a large amount of samples are taken at high speed before an FFT is performed for frequency analysis of the input signal. Figure 32 shows a timing diagram for the AD7484 operating in Parallel Mode 2 with both $\overline{\text{CS}}$ and $\overline{\text{RD}}$ tied low.

AD7484

Data must not be read from the AD7484 while a conversion is taking place. For this reason, if operating the AD7484 at throughput speeds greater than 2.5 MSPS, it is necessary to tie both the \overline{CS} pin and \overline{RD} pin on the AD7484 low and use a buffer on the data lines. This situation may also arise in the case where a read operation cannot be completed in the time after the end of one conversion and the start of the quiet period before the next conversion.

The maximum slew rate at the input of the ADC must be limited to 500 V/ μ s while \overline{BUSY} is low to avoid corrupting the ongoing conversion. In any multiplexed application where the channel is switched during conversion, this is to happen as soon as possible after the \overline{BUSY} falling edge.

Reading Data from the AD7484

Data is read from the part via a 15-bit parallel data bus with the standard \overline{CS} and \overline{RD} signals. The \overline{CS} and \overline{RD} signals are internally gated to enable the conversion result onto the data bus. The data lines D0 to D14 leave their high impedance state when both \overline{CS} and \overline{RD} are logic low. Therefore, \overline{CS} can be permanently tied logic low if required, and the \overline{RD} signal used to access the conversion result. Figure 29 shows a timing specification called t_{QUIET} . This is the amount of time that must be left after any data bus activity before the next conversion is initiated.

Writing to the AD7484

The AD7484 features a user accessible offset register. This allows the bottom of the transfer function to be shifted by ± 200 mV. This feature is explained in more detail in the Offset/Ovrange section.

To write to the offset register, a 15-bit word is written to the AD7484 with the 12 LSBs containing the offset value in twos complement format. The 3 MSBs must be set to 0. The offset value must be within the range -1310 to $+1310$, corresponding to an offset from -200 mV to $+200$ mV. The value written to the offset register is stored and used until power is removed from the device, or the device is reset. The value stored may be updated at any time between conversions by another write to the device. Table 9 shows some examples of offset register values and their effective offset voltage. Figure 30 shows a timing diagram for writing to the AD7484.

Table 9. Offset Register Examples

Code (Decimal)	D14 to D12	D11 to D0 (Twos Complement)	Offset (mV)
-1310	000	1010 1110 0010	-200
-512	000	1110 0000 0000	-78.12
+256	000	0001 0000 0000	+39.06
+1310	000	0101 0001 1110	+200

Driving the \overline{CONVST} Pin

To achieve the specified performance from the AD7484, the \overline{CONVST} pin must be driven from a low jitter source. Because the falling edge on the \overline{CONVST} pin determines the sampling instant, any jitter that may exist on this edge appears as noise when the analog input signal contains high frequency components. The relationship between the analog input frequency (f_{IN}), timing jitter (t_j), and resulting SNR is given by

$$SNR_{JITTER} \text{ (dB)} = 10 \log \left(\frac{1}{(2\pi \times f_{IN} \times t_j)^2} \right)$$

For example, if the desired SNR due to jitter is 100 dB with a maximum full-scale analog input frequency of 1.5 MHz, ignoring all other noise sources, the result is an allowable jitter on the \overline{CONVST} falling edge of 1.06 ps. For a 14-bit converter (ideal SNR = 86.04 dB), the allowable jitter is greater than 1.06 ps, but due consideration must be given to the design of the \overline{CONVST} circuitry to achieve 14-bit performance with large analog input frequencies.

Typical Connection

Figure 23 shows a typical connection diagram for the AD7484 operating in Parallel Mode 1. Conversion is initiated by a falling edge on \overline{CONVST} . When \overline{CONVST} goes low, the \overline{BUSY} signal goes low, and at the end of conversion, the rising edge of \overline{BUSY} is used to activate an interrupt service routine. The \overline{CS} and \overline{RD} lines are then activated to read the 14 data bits (15 bits if using the overrange feature).

In Figure 23, the V_{DRIVE} pin is tied to DV_{DD} , which results in logic output levels being either 0 V or DV_{DD} . The voltage applied to V_{DRIVE} controls the voltage value of the output logic signals. For example, if DV_{DD} is supplied by a 5 V supply and V_{DRIVE} is supplied by a 3 V supply, the logic output levels are either 0 V or 3 V. This feature allows the AD7484 to interface to 3 V devices while still enabling the ADC to process signals at a 5 V supply.

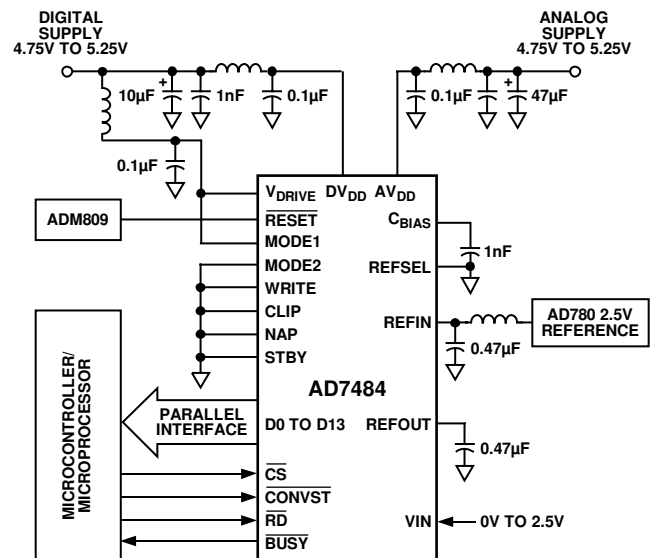

Figure 23. Typical Connection Diagram

BOARD LAYOUT AND GROUNDING

For optimum performance from the AD7484, it is recommended that a PCB with a minimum of three layers be used. One of these layers, preferably the middle layer, should be as complete a ground plane as possible to give the best shielding. The board should be designed in such a way that the analog and digital circuitry is separated and confined to certain areas of the board. This practice, along with not running digital and analog lines close together, helps to avoid coupling digital noise onto analog lines.

The power supply lines to the AD7484 are to be approximately 3 mm wide to provide low impedance paths and reduce the effects of glitches on the power supply lines. It is vital that good decoupling also be present. A combination of ferrites and decoupling capacitors should be used, as shown in Figure 23. The decoupling capacitors are to be as close to the supply pins as possible. This is made easier by the use of multilayer boards. The signal traces from the AD7484 pins can be run on the top layer, while the

decoupling capacitors and ferrites can be mounted on the bottom layer where the power traces exist. The ground plane between the top and bottom planes provides excellent shielding.

Figure 24 to Figure 28 show a sample layout of the board area immediately surrounding the AD7484. Pin 1 is the bottom left corner of the device. The black area in each figure indicates the ground plane present on the middle layer. Figure 24 shows the top layer where the AD7484 is mounted with vias to the bottom routing layer highlighted. Figure 25 shows the bottom layer silkscreen where the decoupling components are soldered directly beneath the device. Figure 26 shows the top and bottom routing layers overlaid. Figure 27 shows the bottom layer where the power routing is with the same via highlighted. Figure 28 shows the silkscreen overlaid on the solder pads for the decoupling components, which are C1 to C6: 100 nF, C7 to C8: 470 nF, C9: 1 nF, and L1 to L4: Meggit-Sigma Chip Ferrite Beads (BMB2A0600RS2).

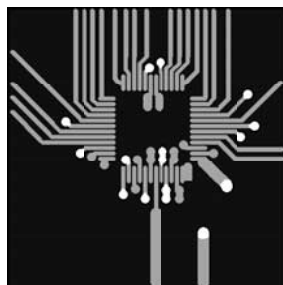

Figure 24. Top Layer Routing



Figure 25. Bottom Layer Silkscreen



Figure 26. Top and Bottom Routing Layers

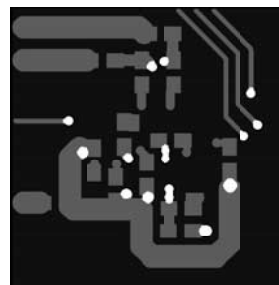

Figure 27. Bottom Layer Routing

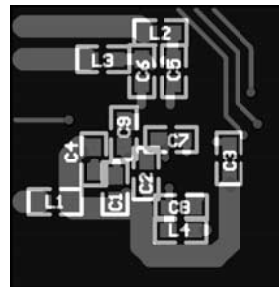

Figure 28. Silkscreen and Bottom Layer Routing

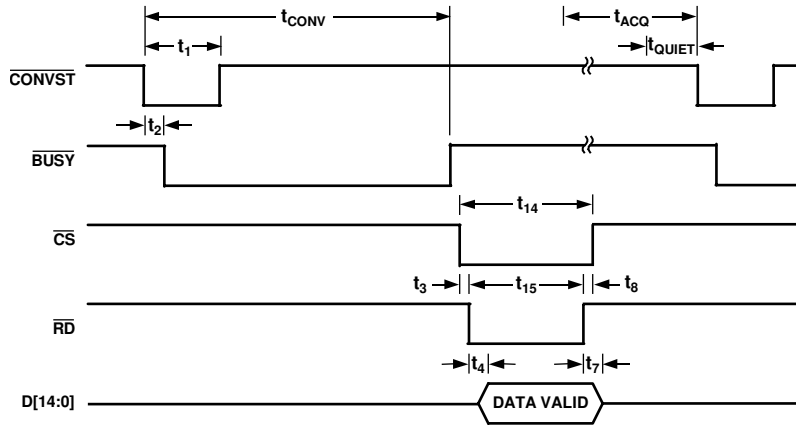

Figure 29. Parallel Mode READ Cycle

02642-029

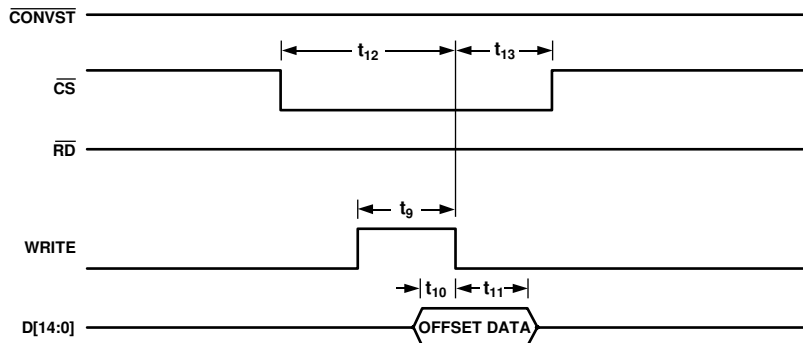

Figure 30. Parallel Mode WRITE Cycle

02642-030

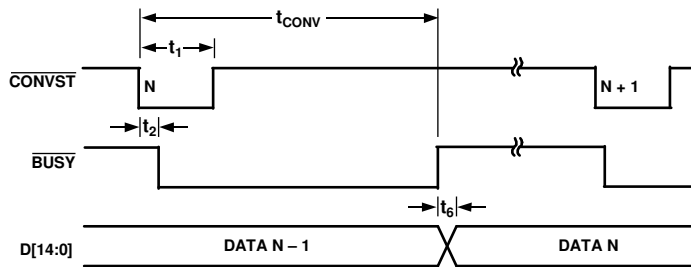

Figure 31. Parallel Mode 1 READ Cycle

02642-031

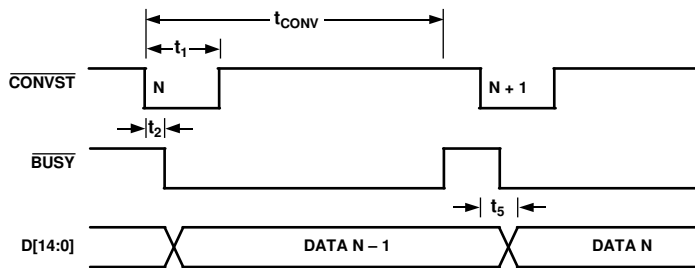
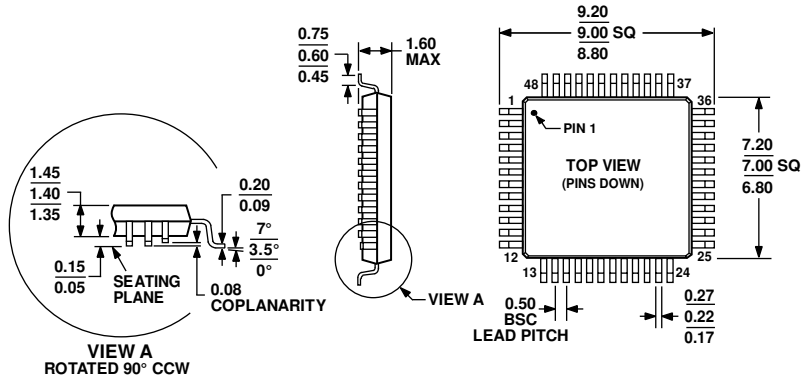

Figure 32. Parallel Mode 2 READ Cycle

02642-032

OUTLINE DIMENSIONS



COMPLIANT TO JEDEC STANDARDS MS-026-BBC

Figure 33. 48-Lead Plastic Quad Flatpack (LQFP)
[ST-48]

Dimensions shown in millimeters

051706-A

ORDERING GUIDE

Model ¹	Temperature Range	Package Description	Package Option
AD7484BSTZ	-40°C to +85°C	48-Lead Plastic Quad Flatpack Package (LQFP)	ST-48
EVAL-AD7484CBZ		Evaluation Board ²	
EVAL-CONTROLBRD2Z		Controller Board ³	

¹ Z = RoHS Compliant Part.

² This can be used as a standalone evaluation board or in conjunction with the controller board for evaluation/demonstration purposes.

³ This board is a complete unit allowing a PC to control and communicate with all Analog Devices evaluation boards ending in the CB designators.

AD7484

NOTES