

REVISIONS			
REV	DESCRIPTION, ECN, EAR NO.	DATE	APP'D
B	PER ECN 07093	APR03/07	L.CHAN
C	ADD PLATING GOLD OPTION	APR07/17	L.CHAN
D	FIX THE ERROR	NOV03/21	L.CHAN
E	ADD INFORMATION IN NOTES	DEC13/21	L.CHAN

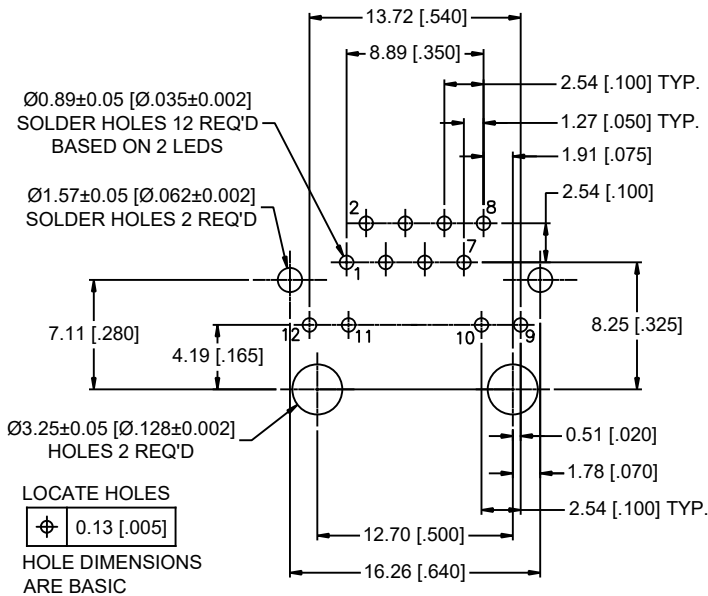
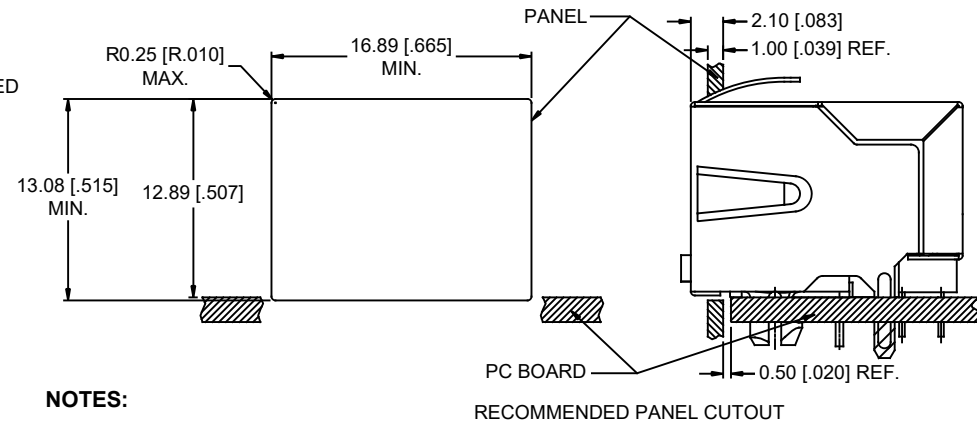

RECOMMENDED P.C.B LAYOUT
COMPONENT SIDE OF PC BOARD

AMPHENOL PART NO.: RJSBE-X38X-C1X

GOLD PLATING OPTION:
D = 6u" GOLD PLATING
G = 15u" GOLD PLATING
J = 30u" GOLD PLATING
5 = 50u" GOLD PLATING

REFER TO LED OPTIONS DRAWING
FOR ORDERING CODES



NOTES:

- MATERIALS:**
CONTACTS: PHOSPHOR BRONZE,
PLATING: SELECTIVE GOLD PLATING ON MATING SURFACES. SEE PART NO. FOR THICKNESS. 50 MICRO" MIN. NICKEL OVERALL.
HOUSING: HIGH TEMPERATURE THERMOPLASTIC, FLAMMABILITY RATING UL 94V-0 COLOR - BLACK.
SHIELD: COPPER ALLOY
PLATING: NIVKEL WITH TIN DIPPED PCB TAILS.
- MECHANICAL CHARACTERISTICS:**
MATING FORCE: 5.0 LBS MAXIMUM
DURABILITY: 750 CYCLES FOR 50u" GOLD PLATING
- ELECTRICAL CHARACTERISTICS:**
CONTACT RESISTANCE: 20 MILLIOHMS MAXIMUM.
INSULATION RESISTANCE: 500 MEGOHMS MINIMUM
CURRENT RATING: 1.5 AMPS PER CONTACT
VOLTAGE RATING: 125 VOLTS AC
- ENVIRONMENTAL:**
OPERATING TEMPERATURE: -55°C TO +85°C
- RECOMMENDED SOLDERING TEMPERATURE:**
WAVE SOLDERING PEAKED AT 260°C FOR 5-8 SECONDS.

UNLESS SPECIFIED OTHERWISE	DRAWN J.OUYANG	APR03/07
PRIMARY UNITS MILLIMETERS	CHECKED MT.CHEN	APR17/07
SECONDARY INCHES	M.E. APP'D	
REFERENCE IN PARENTHESES	Q.A. APP'D	
GENERAL TOLERANCES	DWG APP'D	
1 DECIMAL PLACE	ENG. REL. NO. ECN 07093	
2 DECIMAL PLACES ±0.38	REF.	
3 DECIMAL PLACES		
ANGULAR DEGREES ±1.5°	THIRD ANGLE PROJECTION	DO NOT SCALE DRAWING

Amphenol Canada Corp. Commercial Products	
MODULAR JACK, 8 CONTACTS, WITH LEDS OPTIONS, SHIELDED, .050" CONTACT TAIL SPACING, FORWARD LED TAILS - RoHS COMPLIANT	
DWG NO.	P-RJSBE-X38X-C1X
CODE ID NO. 03554	DWG SIZE X SCALE XX:1 SHEET 1 OF 2

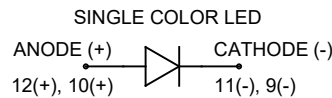
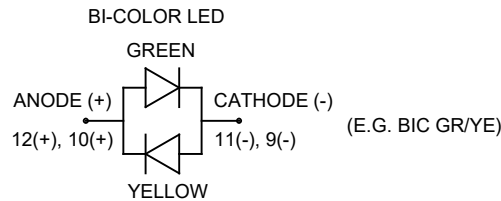
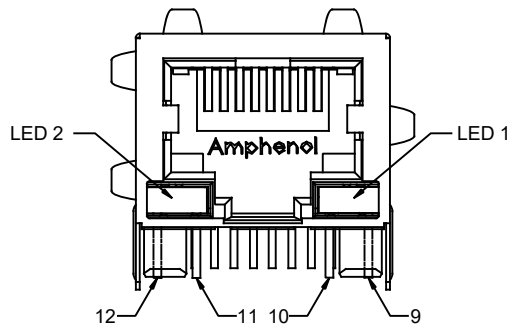

LED SCHEMATIC

EXAMPLE:
AMPHENOL PART NUMBER: RJSBE-X38X-C1

LED COLOR CODE

CODE	LED 2 (LEFT)	LED 1 (RIGHT)	CODE	LED 2 (LEFT)	LED 1 (RIGHT)	CODE	LED 2 (LEFT)	LED 1 (RIGHT)
0	BLOCKED	BLOCKED	9	GREEN	BLOCKED	J	BiC RD/GR	YELLOW
1	YELLOW	GREEN	A	BiC GR/YE	BiC GR/YE	K	YELLOW	BiC GR/OR
2	BLOCKED	GREEN	B	BiC RD/GR	BiC RD/GR	L	BiC GR/YE	RED
3	YELLOW	BLOCKED	C	BiC RD/GR	BiC GR/YE	M	RED	YELLOW
4	GREEN	YELLOW	D	GREEN	BiC GR/YE	N	BiC GR/RD	BiC GR/YE
5	GREEN	GREEN	E	YELLOW	BiC GR/YE	P	GREEN	BiC RD/GR
6	YELLOW	YELLOW	F	BiC GR/YE	YELLOW	R	BiC GR/OR	GREEN
7	RED	GREEN	G	BiC GR/OR	BiC GR/OR	T	RED	RED
8	GREEN	RED	H	BiC GR/YE	GREEN	V	BiC RD/GR	GREEN
			W	ADDITIONAL OPTIONS				

EXAMPLE OF ADDITIONAL LED OPTIONS:
AMPHENOL PART NUMBER: RJSBE-X38W-C1X

ADDITIONAL LED COLOR CODE

DENOTES ADDITIONAL LED OPTIONS TO BE USED

CODE	LED 2 (LEFT)	LED 1 (RIGHT)	CODE	LED 2 (LEFT)	LED 1 (RIGHT)	CODE	LED 2 (LEFT)	LED 1 (RIGHT)
0	DO NOT USE		5	BLOCKED	YELLOW	A	LOWC YE	LOWC YE
1	RED	BLOCKED	6	RED	BiC RD/GR	B	LOWC YE	LOWC GR
2	BiC GR/OR	YELLOW	7			C	LOWC GR	LOWC YE
3	YELLOW	RED	8	BiC RD/GR	BLOCKED	D	LOWC GR	LOWC GR
4	BLOCKED	RED	9	BiC GR/YE	BLOCKED	M	LOWC RD	LOWC YE
						N	GREEN	BiC GR/OR
						E	GREEN	ORANGE
						F	ORANGE	GREEN
						G	BiC YE/GR	BiC YE/GR
						P	BiC RD/YE	GREEN
						R	BiC RD/YE	BiC RD/YE
						T	BiC GR/YE	BiC RD/GR
						H	BLUE	RED



REVISIONS			
REV	DESCRIPTION, ECN, EAR NO.	DATE	APP'D
B	PER ECN 07093	APR03/07	L.CHAN
C	ADD PLATING GOLD OPTION	APR07/17	L.CHAN
D	FIX THE ERROR	NOV03/21	L.CHAN
E	ADD INFORMATION IN NOTES	DEC13/21	L.CHAN

NOTES:

- LED SPECIFICATIONS:
FORWARD VOLTAGE: 1.8~3.4 VOLTS.
REVERSE VOLTAGE: 5.0 VOLTS MAX.
LUMINOUS INTENSITY: 3~60 mcd (AT If=20mA)
STORAGE TEMPERATURE: -55° TO 85° C
PLATING ON TAILS: TIN OR TIN/COPPER ALLOY OVER SILVER
- PRIMARY COLOR FOR BI-COLOR LEDS IN STANDARD ANODE/CATHODE CONFIGURATION IS:
RED-GREEN= RED
RED-YELLOW= RED
GREEN-YELLOW= GREEN
- LEGEND
BiC=BI-COLOR LED
LOWC=LOW CURRENT LED
YE=YELLOW
GR=GREEN
RD=RED
OR=ORANGE

UNLESS SPECIFIED OTHERWISE	DRAWN J.OUYANG	APR03/07
PRIMARY UNITS MILLIMETERS	CHECKED MT.CHEN	APR17/07
SECONDARY INCHES	M.E. APP'D	
REFERENCE IN PARENTHESES	Q.A. APP'D	
GENERAL TOLERANCES		DWG APP'D
1 DECIMAL PLACE	ENG. REL. NO. ECN 07093	
2 DECIMAL PLACES ±0.38	REF.	
3 DECIMAL PLACES		
ANGULAR DEGREES ±1.5°	THIRD ANGLE PROJECTION	DO NOT SCALE DRAWING

Amphenol Canada Corp.
Commercial Products

MODULAR JACK, 8 CONTACTS, WITH LEDS OPTIONS, SHIELDED, .050" CONTACT TAIL SPACING, FORWARD LED TAILS - RoHS COMPLIANT

DWG NO.	P-RJSBE-X38X-C1X	REV	E
CODE ID NO. 03554	DWG SIZE X	SCALE XX:1	SHEET 2 OF 2