

REVISIONS				
P	LTR	DESCRIPTION	DATE	APVD
	D	REVISED PER ECR-22-152397	06OCT2022	BB DSC

<b>AMP</b> WIRE RANGE	Listed FILE E13288	LR7189 Certified
16-14 AWG SOLID OR STRANDED	16-14 AWG SOLID OR STRANDED	16-14 AWG SOLID OR STRANDED

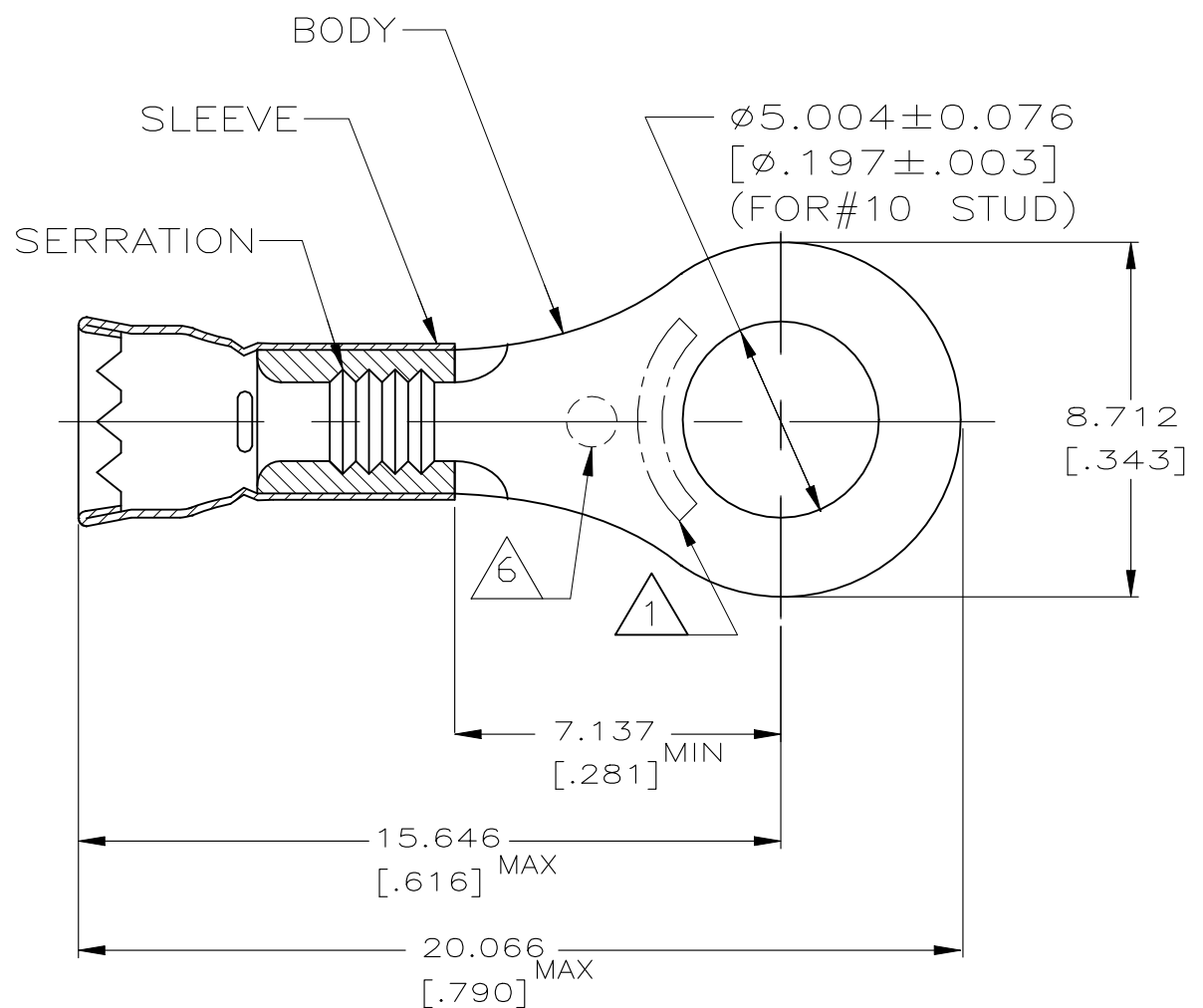

- 1 STAMP AMP 16-14\* APPROX AS SHOWN
- 2. WIRE INSULATION DIAMETER:  
Ø2.921 [.115] TO Ø4.318 [.170]
- 3. BODY MATERIAL THK: 0.787 ± 0.051 [.031 ± .002]
- 4 MATERIAL:  
BODY & SLEEVE - COPPER PER ASTM B152
- 5 FINISH:  
BODY & SLEEVE - TIN PLATE 0.00254 [.000100]  
MIN EXT THK PER ASTM B545
- 6 "O" STAMP MARK OPTIONAL

5000	ON TAPE, REEL	2-30928-1
1000	LOOSE PIECE	30928
QTY	PACKAGE TYPE	PART NO

AMP INCORPORATED CUSTOMER SERVICE SYSTEMS		MAX RECOMMENDED OPERATING TEMPERATURE: 170°C [338°F]	THIS DRAWING IS A CONTROLLED DOCUMENT.		DWN L OLMEDA 23JAN95	TE Connectivity			
FOR ADDITIONAL PRODUCT INFORMATION OR COPIES OF DRAWINGS AND TECHNICAL DOCUMENTS	PRODUCT INFORMATION CENTER 1-800-522-6752	VOLTAGE RATING: -	DIMENSIONS: mm [INCHES]	TOLERANCES UNLESS OTHERWISE SPECIFIED:	CHK M ELLIS 23JAN95				NAME
FOR APPLICATION TOOLING INFORMATION	TOOLING ASSISTANCE CENTER 1-800-722-1111	CIRCULAR MIL AREA: 1.04mm <sup>2</sup> -2.62mm <sup>2</sup> [2050-5180]		0 PLC ± - 1 PLC ± - 2 PLC ± - 3 PLC ± 0.127[.005] 4 PLC ± - ANGLES ± -	APVD S BORTNER 23JAN95	PRODUCT SPEC UL486A-B			
FOR ORDER ENTRY	1-800-526-5142	MATERIAL 4		FINISH 5	APPLICATION SPEC -	SIZE A3	CAGE CODE 00779	DRAWING NO C-30928	RESTRICTED TO -
CUSTOMER DRAWING					WEIGHT -	SCALE 6:1	SHEET 1 OF 1	REV D	