

THIS DRAWING IS UNPUBLISHED. RELEASED FOR PUBLICATION APRIL , 2004.
 © COPYRIGHT 2004 By - ALL RIGHTS RESERVED.

REVISIONS					
P	LTR	DESCRIPTION	DATE	DWN	APVD
	C	REVISED PER ECO-14-011634	19JAN2020	RZ	RS

- NOTES:
- ① SINGLE PACK IN ACCORDANCE WITH SPEC 107-3275
 - ② 100 TRAY PACK IN ACCORDANCE WITH SPEC 107-3275
 - ③ Au PLATING
 - 4 FOR TECHNICAL DATA REFER TO YOUR LOCAL TYCO ELECTRONICS SALES OFFICE
 - 5 ALL DIMENSIONS ARE NOMINAL FOR REFERENCE ONLY UNLESS OTHERWISE STATED
 - 6 OPERATING TEMPERATURE RANGE: -65°C~+165°C
 - 7 DURABILITY: 500 CYCLES

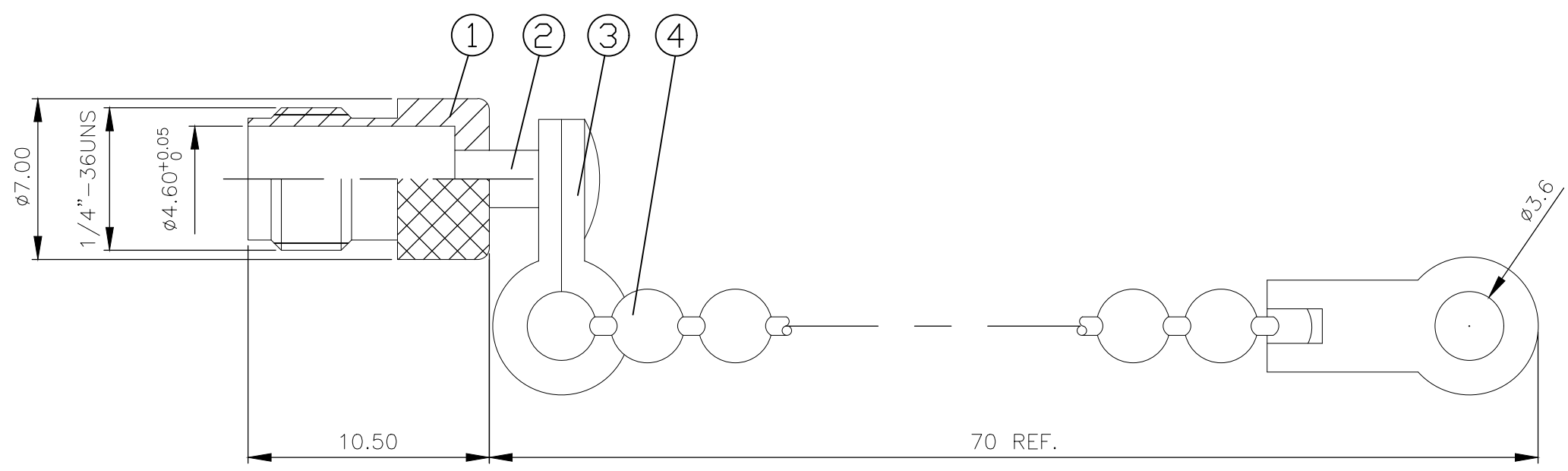

QTY	QTY	MATERIAL	DESCRIPTION	ITEM
1	1	BRASS	CHAIN	4
1	1	STAINLESS STEEL	JOINT	3
1	1	BRASS	RIVET	2
1	1	BRASS	SHELL	1
3--1	3--0	MATERIAL	DESCRIPTION	ITEM
②	①			

THIS DRAWING IS A CONTROLLED DOCUMENT.		DWN R.SMITH 13FEB04	TE Connectivity		
DIMENSIONS: mm		CHK S.PARLOW 13FEB04			
TOLERANCES UNLESS OTHERWISE SPECIFIED:		APVD F.WHEELER-KING 13FEB04	NAME SMA JACK DUST CAP AND CHAIN		
0 PLC ± - 1 PLC ± 0.2 2 PLC ± 0.1 3 PLC ± 0.05 4 PLC ± - ANGLES ± 5°		PRODUCT SPEC 108-3460	RESTRICTED TO		
MATERIAL SEE TABLE		FINISH -	APPLICATION SPEC -	SIZE A3	CAGE CODE 00779
		WEIGHT 0.000000	DRAWING NO C-1478986	SCALE 1:1	
		CUSTOMER DRAWING		SHEET 1 OF 1	REV C