

REVISIONS					
REV	ECO	DESCRIPTION	DATE	BY	APPR
A1	-	RELEASE NEW PRODUCT	13/Mar/20	ROOKIE	TOMMY

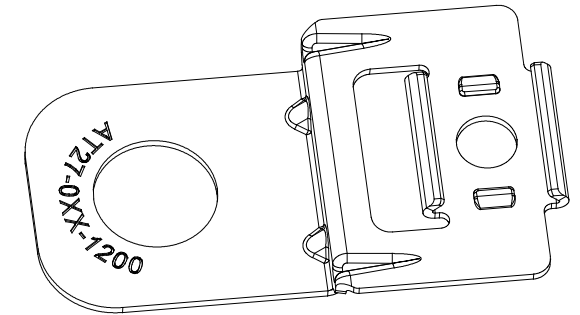

TITLE: SIDE MOUNTING CLIP AT/ATM/ATP/ATV/ATHD,METAL  
 DWG NO: AT27-XXX-1200  
 REV: A1  
 SH: 1  
 OF: 1

NOTES: UNLESS OTHERWISE SPECIFIED

- USE WITH CONNECTORS
  - A. AT04-2/3/4/6/12P\*
  - B. ATM04-2/3/4/6/8/12P\*
  - C. ATP04-2/4/6P\*
  - D. ATV04-\*
  - E. ATHD04-\*
 (\* =ALL MODIFICATIONS AND/OR COLORS )

2. RoHS COMPLIANT

3. ALL DIMENSIONS ARE FOR REFERENCE USE ONLY.

**PART INFORMATION:**

PART NUMBER	MATERIAL	HOLE DIAMETER
AT27-007-1200	STEEL-ZINC PLATED	NO HOLE
AT27-008-1200	STEEL-ZINC PLATED	11mm
AT27-009-1200	STEEL-ZINC PLATED	13mm
AT27-017-1200	STEEL-ZINC PLATED	8.2mm

SEE TABLE		REF: 1027-007-1200, 1027-008-1200, 1027-009-1200, 1027-017-1200	
QUANTITY	PART NUMBER	DESCRIPTION	ITEM
<b>MATERIALS LIST</b>			
UNLESS OTHERWISE SPECIFIED: 1) All dimensions are in metric(mm). 2) Tolerances are as follows: 1 PL DEC ±0.30 2 PL DEC ±0.15 3 PL DEC ±0.08 3) Note reference =		SIGNATURES	DATE
		DRAWN: ROOKIE	13/Mar/20
		CHECKED: ORION	15/Mar/20
		ENGINEER:	
		APPROVAL: TOMMY	16/Mar/20
MATERIAL SPECIFICATIONS:		CUSTOMER:	
PROCESS SPECIFICATIONS:		THIS DRAWING IS SUPPLIED FOR INFORMATION ONLY. DESIGN FEATURES, SPECIFICATIONS AND PERFORMANCE DATA SHOWN HEREON ARE THE PROPERTY OF THE AMPHENOL CORPORATION. NO RIGHTS OF REPRODUCTION ARE IMPLIED. ALL DIMENSIONS ARE SUBJECT TO NORMAL MANUFACTURING VARIATIONS.	
NEXT ASSY:		SIZE: <b>B</b>	DWG NO: <b>AT27-XXX-1200</b>
		SCALE: NONE	REVISION: <b>A1</b>
		SHEET 1	OF 1

**SINE Systems Corporation**  
 A Subsidiary of Amphenol Corporation  
 44724 Morley Drive  
 Clinton Township, MI 48036

**SIDE MOUNTING CLIP**  
**AT/ATM/ATP/ATV/ATHD,METAL**