

PART NUMBER	ENGINEERING NO.	LENGTH
1300250482	DNF99A-M010	3' 3" +2.19 - 0 [1.0M +55.6 - 0]
1300250542	DNF99A-M030	9' 10" +3.50 - 0 [3.0M +88.9 - 0]
1300250486	DNF99A-M050	16' 5" +6.50 - 0 [5.0M +165.1 - 0]

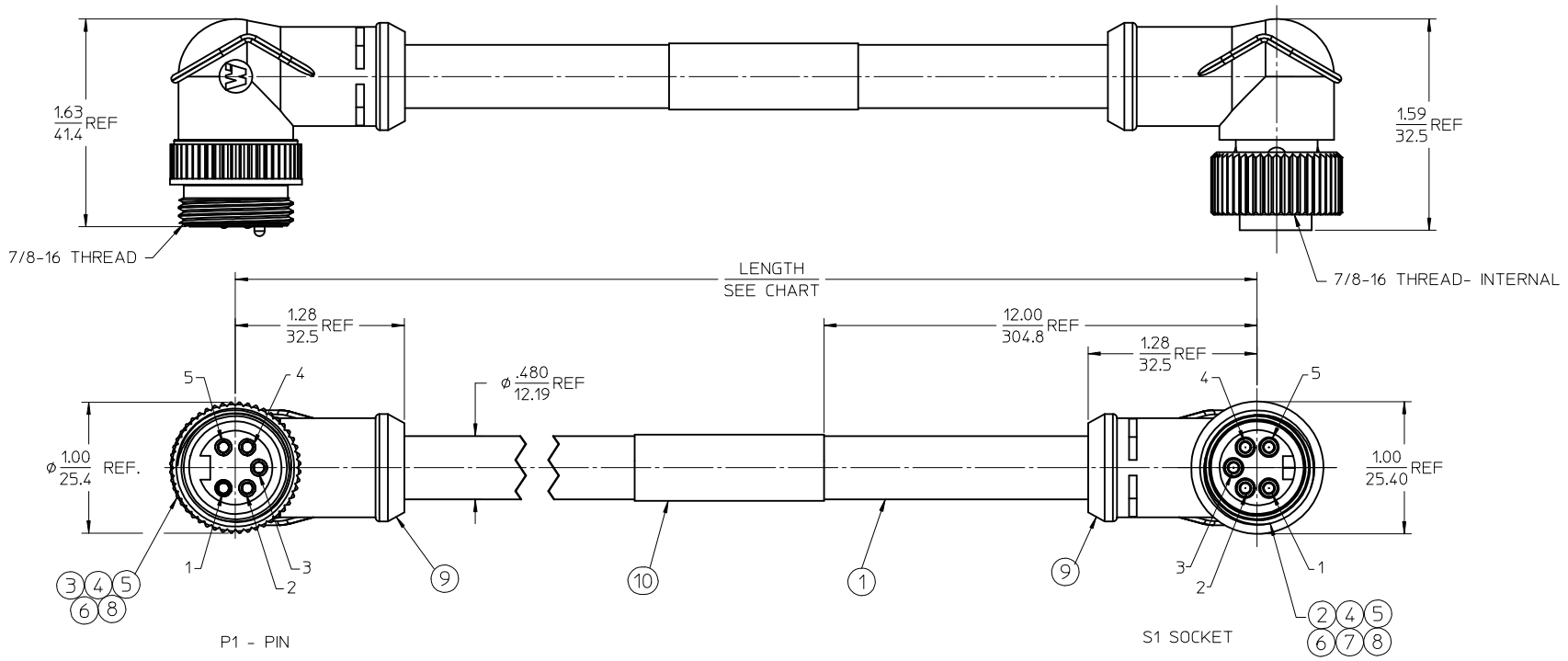
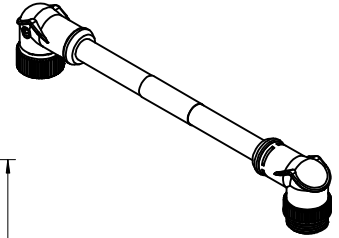

- NOTES:
1. MATERIAL: SEE TABLE
 2. FINISHES: SEE TABLE
 3. CABLE ASSEMBLIES ARE BAGGED SEPERATELY IN POLY BAGS WITH BARCODE LABEL ATTACHED TO OUTSIDE OF BAG
 4. WRAP LABEL IS MARKED WITH P/N, DATE CODE VOLTAGE & AMPERAGE
 5. MATES WITH: MINI CHANGE, A-SIZE 5 POLE RECEPTACLE
 6. ELECTRICAL SPECIFICATIONS:
VOLTAGE RATING: 300V
CURRENT RATING: 4 AMPS
 7. ASSEMBLY IS RoHS COMPLIANT

P1		S1
1	DRAIN	1
2	RED +V	2
3	BLACK -V	3
4	WHITE CAN H	4
5	BLUE CAN L	5

WIRING DIAGRAM

ITEM	QTY.	DESCRIPTION	MATERIAL	FINISH
10	1	LABEL	PLASTIC FILM	BLACK/YELLOW
9	1	OVERMOLD	PVC	GRAY
8	1	COUPLING NUT	ZINC DIE CAST	BLACK
7	1	FRICTION RING	NYLON	WHITE
6	5	SOCKET SLEEVE	ST. STEEL	
5	3	CONTACT, 18 AWG	BRASS	GOLD PLATED
4	2	CONTACT, 15 AWG	BRASS	GOLD PLATED
3	1	INSERT, MALE, 5 POLE	PVC	GRAY
2	1	INSERT, FEMALE, 5 POLE	PVC	GRAY
1	1	CABLE-MID, DEV-NET, TRUNK, 18/2, 15/2	PVC JACKET	GRAY

RELEASED EC NO: MNA2010-0048 DRAWN: RUPERT CHKD: APPR: J. MURPHY 2009/07/17 2009/07/20	DESCRIPTION REV	QUALITY SYMBOLS	GENERAL TOLERANCES (UNLESS SPECIFIED)	DIMENSION STYLE	SCALE	DESIGN UNITS	THIRD ANGLE PROJECTION																													
		$\nabla=0$ $\nabla=0$	<table border="1"> <thead> <tr> <th></th> <th>mm</th> <th>INCH</th> </tr> </thead> <tbody> <tr> <td>4 PLACES</td> <td>± ---</td> <td>± ---</td> </tr> <tr> <td>3 PLACES</td> <td>± ---</td> <td>± ---</td> </tr> <tr> <td>2 PLACES</td> <td>± ---</td> <td>± ---</td> </tr> <tr> <td>1 PLACE</td> <td>± ---</td> <td>± ---</td> </tr> </tbody> </table>		mm	INCH	4 PLACES	± ---	± ---	3 PLACES	± ---	± ---	2 PLACES	± ---	± ---	1 PLACE	± ---	± ---	<table border="1"> <thead> <tr> <th>IN/MM</th> <th>DATE</th> </tr> </thead> <tbody> <tr> <td>DRAWN BY B. RUPERT</td> <td>07/13/2007</td> </tr> <tr> <td>CHECKED BY</td> <td>DATE</td> </tr> <tr> <td>B. WOODMAN</td> <td>07/13/2007</td> </tr> <tr> <td>APPROVED BY J. MURPHY</td> <td>07/13/2007</td> </tr> </tbody> </table>	IN/MM	DATE	DRAWN BY B. RUPERT	07/13/2007	CHECKED BY	DATE	B. WOODMAN	07/13/2007	APPROVED BY J. MURPHY	07/13/2007	<table border="1"> <thead> <tr> <th>TITLE</th> <th>DOCUMENT NO.</th> <th>SHEET NO.</th> </tr> </thead> <tbody> <tr> <td>MINI-CHANGE M/FE, 5P 90/90 DEG, DEVICE NET TRUNK CABLE - THK FLEX</td> <td>SD-130025-018</td> <td>1 OF 1</td> </tr> </tbody> </table>	TITLE	DOCUMENT NO.	SHEET NO.	MINI-CHANGE M/FE, 5P 90/90 DEG, DEVICE NET TRUNK CABLE - THK FLEX	SD-130025-018	1 OF 1
			mm	INCH																																
		4 PLACES	± ---	± ---																																
3 PLACES	± ---	± ---																																		
2 PLACES	± ---	± ---																																		
1 PLACE	± ---	± ---																																		
IN/MM	DATE																																			
DRAWN BY B. RUPERT	07/13/2007																																			
CHECKED BY	DATE																																			
B. WOODMAN	07/13/2007																																			
APPROVED BY J. MURPHY	07/13/2007																																			
TITLE	DOCUMENT NO.	SHEET NO.																																		
MINI-CHANGE M/FE, 5P 90/90 DEG, DEVICE NET TRUNK CABLE - THK FLEX	SD-130025-018	1 OF 1																																		
		ANGULAR ±1/2°	SEE CHART	MOLEX MOLEX INCORPORATED																																
		DRAFT WHERE APPLICABLE MUST REMAIN WITHIN DIMENSIONS	SIZE C	THIS DRAWING CONTAINS INFORMATION THAT IS PROPRIETARY TO MOLEX INCORPORATED AND SHOULD NOT BE USED WITHOUT WRITTEN PERMISSION																																