

THESE DRAWINGS ARE THE PROPERTY OF QUALTEK ELECTRONICS AND NOT TO BE REPRODUCED FOR OR COMMUNICATED TO A THIRD PARTY WITHOUT THE EXPRESS WRITTEN PERMISSION OF AN OFFICER OF QUALTEK ELECTRONICS.

REVISION			
REV.	DESCRIPTION	DATE	APPROVED

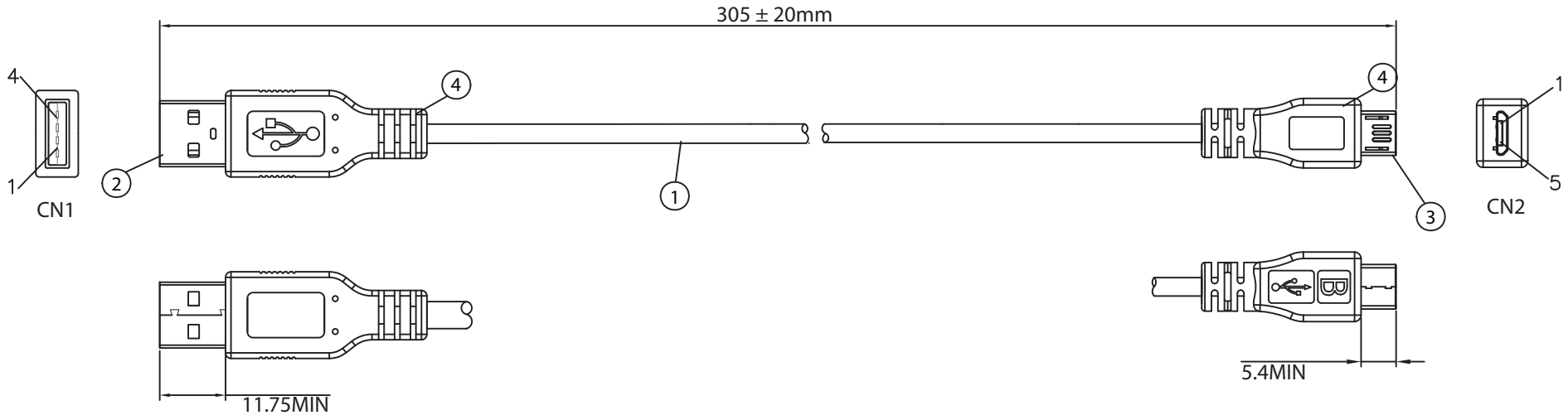

CONNECTION

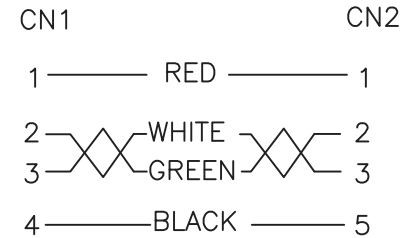

SHELL — BRAID&DRAIN — SHELL

NOTES:

1. CABLE: UL2725  
28AWG\*1PR+28AWG\*2C+AEB(AL) 65%  
OUTER JACKET: BLACK, OD: 4.0 ± 0.2mm
2. CONNECTOR: USB 2.0 A TYPE MALE  
INSULATOR: WHITE PBT  
PIN G/F  
NICKEL PLATED SHELL
3. CONNECTOR: MICRO USB 2.0 B TYPE MALE  
INSULATOR: BLACK  
PIN G/F  
NICKEL PLATED SHELL
4. PVC MOLDED: 45P BLACK COLOR
5. ELECTRICAL TEST:  
<1>.100% OPEN SHORT & MISS WIRE TEST  
<2>.INSULATION RESISTANCE: DC300V 10M ohm MIN.  
<3>.CONDUCTOR RESISTANCE: 2 ohm MAX.

**CONTROLLED**

Dim range (mm)	Tolerance +/- (mm)	<b>Qualtek Electronics Corp.</b> WCI DIVISION		
		Part Number: 3025033-01		<span style="border: 1px solid green; padding: 2px;">RoHS Compliant</span>
0-1	0.15	Description: USB 4P(A)/M - MICRO USB 5P(B)/M		
1-6	0.20			
6-18	0.30			
18-50	0.50	UNIT: mm		
50-120	0.70	Drawn / Date	Checked / Date	Approved / Date
120-250	0.90	R. Nuti 08-30-16	08-30-16	LY / 08-30-16
250-500	1.20			