

AT ALL TIMES WATER RESISTANT CONNECTORS NOT IN USE SHOULD BE COVERED WITH A CONEC WATER RESISTANT CAP OR WATER TIGHT HOOD.

$\varnothing 0,6 \pm 0,05$ (15x) (5 : 1)

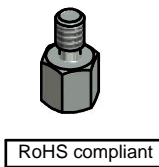
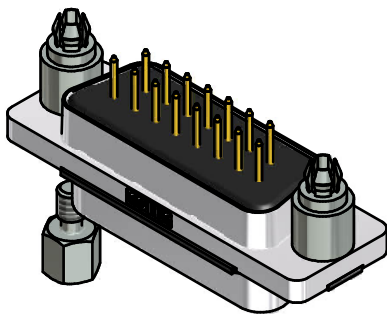
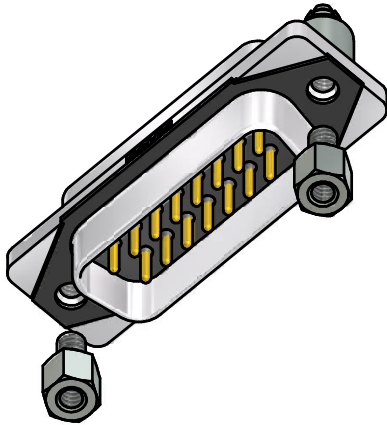
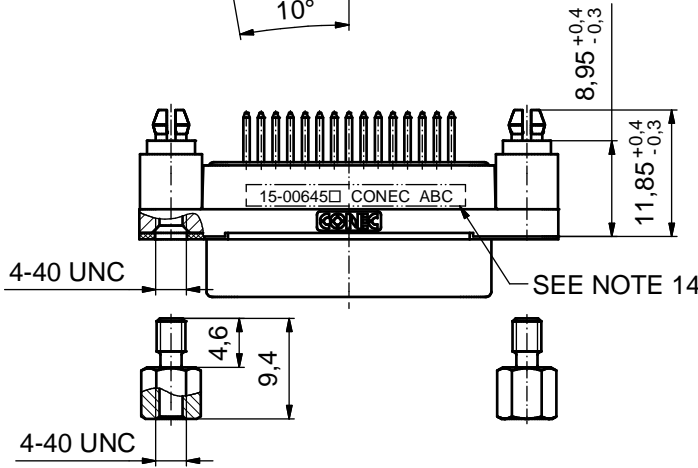
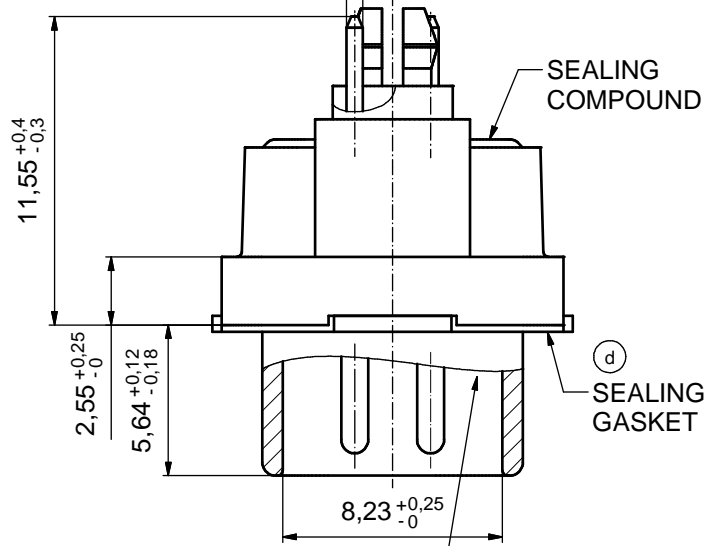
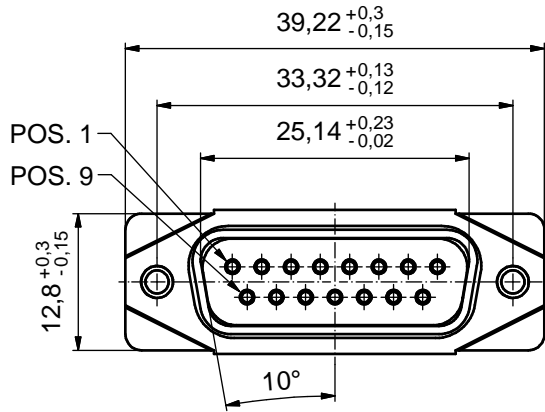

NOTES:

1. FOR WAVESOLDERING (SOLDER BATH TEMPERATURE 265°C FOR 8 SEC. AND SOLDER PREHEAT 150°C FOR 180 SEC.)
2. IP RATING: IP 67
3. SEALED TO WITHSTAND PRESSURE UP TO 1,45 PSI FOR 30 MINUTES AFTER SOLDERING
4. METAL SHELL: ZINC DIE CAST; min. 50µm NICKEL PLATING over COPPER
5. INSULATORS: PBT GF UL 94 V-0
6. SEALING GASKET: SILICONE
7. RUBBER GASKET: TPE
8. SEALING COMPOUND: EPOXY
9. CONTACTS: COPPER ALLOY; PLATING (SEE PART-NO.):
 PLEASE ADD 1 for 30µm HARD GOLD over min. 50µm NICKEL
 PLEASE ADD 3 for GOLD FLASH over NICKEL
10. REAR SPACER CLIPS: COPPER ALLOY; min. 200µm TIN over 80µm NICKEL
 PCB-HOLE: $\varnothing 3,1 \pm 0,1$ mm; PCB THICKNESS 1,6mm
11. HEXLOCKING SCREWS: STAINLESS STEEL
12. P.C.B. HOLE DRILLINGS and RECOMMENDED PANEL CUT-OUT ON SHEET 2
13. RECOMMENDED TORQUE FOR MOUNTING SCREW
 35Ncm (3.1 in.LB) / max. 67Ncm (6 in.LB)
14. CONNECTOR IS PART MARKED: **15-00645 CONEC ABC** (see note 9)

THIS DRAWING MAY NOT BE COPIED OR REPRODUCED IN ANY WAY, AND MAY NOT BE PASSED ON TO A THIRD PARTY WITHOUT WRITTEN PERMISSION. OWNERSHIP AND COPYRIGHT OF CONEC GmbH				tolerance		dim. in mm	scale: 2:1 (5:1)	
				date			material: SEE NOTES	
DO NOT ALTER CAD DRAWING BY HAND				drawn	11.09.14	name		title: D-SUB MALE 15pos. SOLDER PIN STRAIGHT with closed 4-40 UNC thread and rear spacer clip
				appd.	26.01.15	Fischer		
2 x d	Ä6417	17.05.17	Lehm.	norm			dwg no: 15K1A1546	DIN-A3 sh: 1
1 x c	Ä5827	25.09.15	Unkrüer	d-old				
2 x b	Ä5800	04.09.15	M.H.			part no: 15-00645 (see note 9)		
a	Original							
rev.	description	date	name	CONEC				

P.C.B. HOLE DRILLINGS

(P.C.B. TOP SIDE)

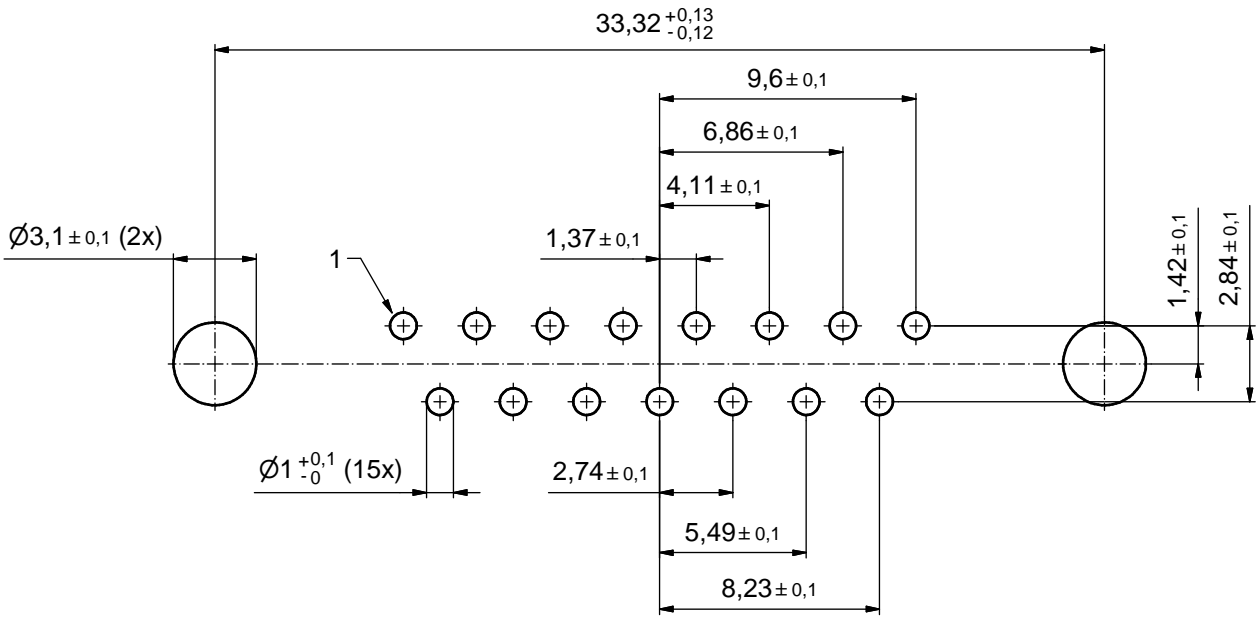

RECOMMENDED PANEL CUT-OUT

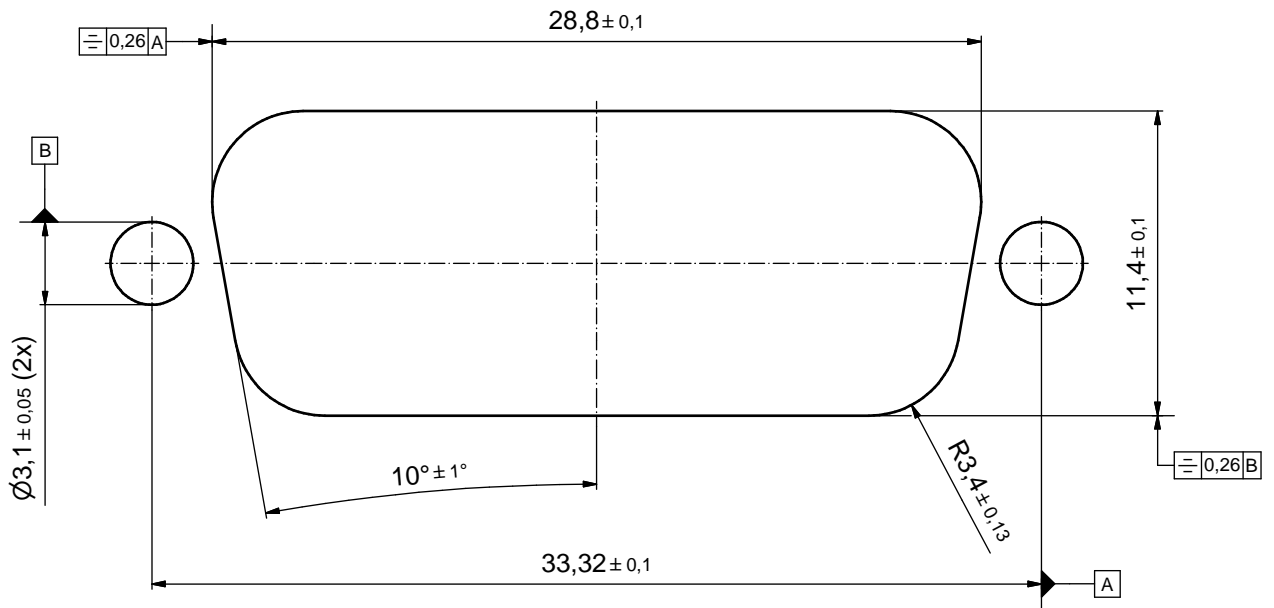

THIS DRAWING MAY NOT BE COPIED OR REPRODUCED IN ANY WAY, AND MAY NOT BE PASSED ON TO A THIRD PARTY WITHOUT WRITTEN PERMISSION. OWNERSHIP AND COPYRIGHT OF CONEC GmbH DO NOT ALTER CAD DRAWING BY HAND	tolerance		dim. in mm		scale:	5:1
					material:	SEE SHEET 1
	drawn	11.09.14	Lehmenkühler		title:	
	appd.	26.01.15	Fischer		P.C.B. HOLE DRILLINGS	
	norm				RECOMMENDED PANEL CUT-OUT	
d-old				D-SUB MALE 15pos. SOLDER PIN STRAIGHT		
a	Original			dwg no:	15K1A1546	DIN-A3
rev.	description	date	name	part no: SEE SHEET 1		sh: 2