

Mallory Sonalert Products, Inc.

Part #:

SC250HR

Sales Outline Drawing

Revision:

E

Specifications:

| | |
|-----------------------|--|
| Sound Level Category | Medium |
| Mode of Operation | Continuous |
| Voltage Rating | 60 to 250 VAC/DC |
| Frequency | 4500 ± 500 Hz |
| Loudness @ 2 FT | 75 to 87 dB(A) Typ. |
| Loudness @ Min Vdc | 68 dB(A) @ 2 Feet and 60 Vdc |
| Loudness @ Max Vdc | 80 dB(A) @ 2 Feet and 250 Vdc |
| Current Draw | 5-16mA |
| Housing Material | 6/6 Nylon, Color: Black |
| Storage Temperature | -40° to +85° C |
| Operating Temperature | -30° to +65° C |
| Panel Mounting | Recommended hole size is 1.25"(31.75mm). Thread front will fit standard 30mm(1.181") hole. |
| Knurled Nut | Used to attach part to panel. The max recommended torque is 10 in-lbs. |
| Weight (Typical) | 1.6 oz (45g) |
| NEMA 3R,4X, & 12 | Approved with use of ACC03. |
| Options | Please contact factory. |

Dimensions: Inches (mm)

ROHS Compliant

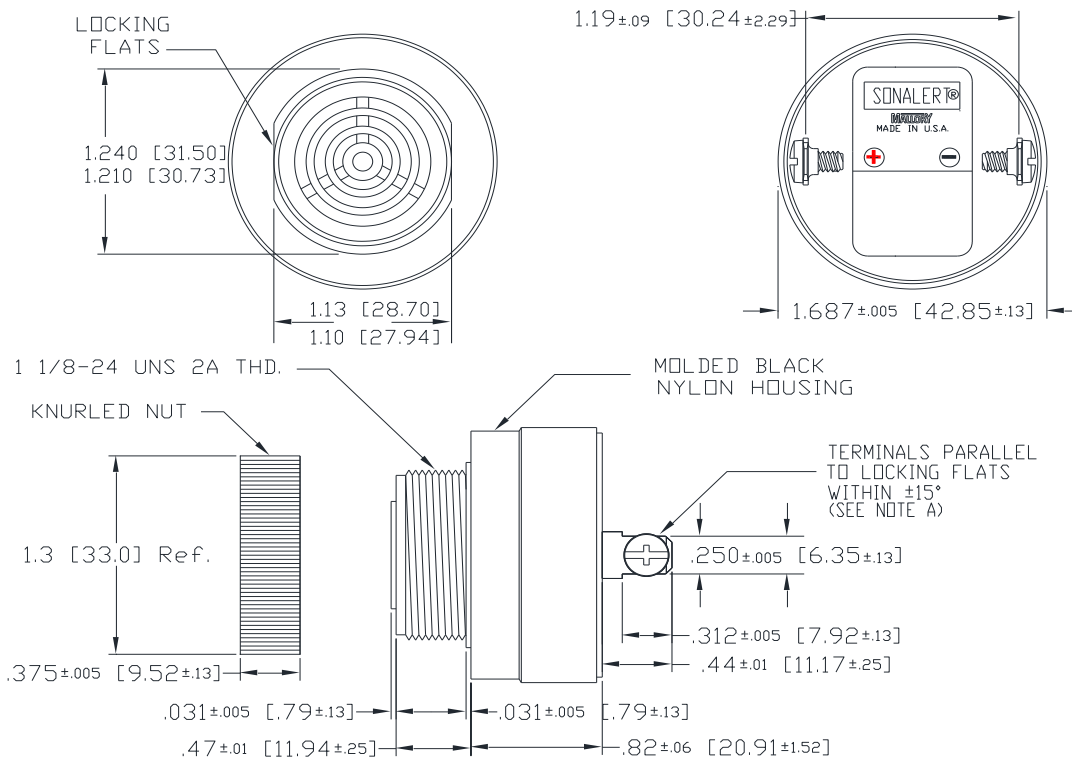

NOTE A: TERMINALS-.032 BRASS TIN PLATED, TAPPED FOR #6-32 SCREW. TWO #6-32 NICKEL PLATED BRASS SCREWS INCLUDED. WILL ACCEPT 1/4" QUICK CONNECT.

NOTE B: MOUNTING- REMOVE BLACK PLASTIC NUT AND INSERT THREADED FRONT THROUGH 1.25" HOLE PUNCHED IN PANEL, IF ORIENTATION IS NEEDED, NOTE LOCKING FLATS ON DRAWING. SCREW NUT BACK ON. DO NOT OVERTIGHTEN.