



Is Now Part of



ON Semiconductor®

To learn more about ON Semiconductor, please visit our website at
www.onsemi.com

Please note: As part of the Fairchild Semiconductor integration, some of the Fairchild orderable part numbers will need to change in order to meet ON Semiconductor's system requirements. Since the ON Semiconductor product management systems do not have the ability to manage part nomenclature that utilizes an underscore (_), the underscore (_) in the Fairchild part numbers will be changed to a dash (-). This document may contain device numbers with an underscore (_). Please check the ON Semiconductor website to verify the updated device numbers. The most current and up-to-date ordering information can be found at www.onsemi.com. Please email any questions regarding the system integration to Fairchild_questions@onsemi.com.

ON Semiconductor and the ON Semiconductor logo are trademarks of Semiconductor Components Industries, LLC dba ON Semiconductor or its subsidiaries in the United States and/or other countries. ON Semiconductor owns the rights to a number of patents, trademarks, copyrights, trade secrets, and other intellectual property. A listing of ON Semiconductor's product/patent coverage may be accessed at www.onsemi.com/site/pdf/Patent-Marking.pdf. ON Semiconductor reserves the right to make changes without further notice to any products herein. ON Semiconductor makes no warranty, representation or guarantee regarding the suitability of its products for any particular purpose, nor does ON Semiconductor assume any liability arising out of the application or use of any product or circuit, and specifically disclaims any and all liability, including without limitation special, consequential or incidental damages. Buyer is responsible for its products and applications using ON Semiconductor products, including compliance with all laws, regulations and safety requirements or standards, regardless of any support or applications information provided by ON Semiconductor. "Typical" parameters which may be provided in ON Semiconductor data sheets and/or specifications can and do vary in different applications and actual performance may vary over time. All operating parameters, including "Typicals" must be validated for each customer application by customer's technical experts. ON Semiconductor does not convey any license under its patent rights nor the rights of others. ON Semiconductor products are not designed, intended, or authorized for use as a critical component in life support systems or any FDA Class 3 medical devices or medical devices with a same or similar classification in a foreign jurisdiction or any devices intended for implantation in the human body. Should Buyer purchase or use ON Semiconductor products for any such unintended or unauthorized application, Buyer shall indemnify and hold ON Semiconductor and its officers, employees, subsidiaries, affiliates, and distributors harmless against all claims, costs, damages, and expenses, and reasonable attorney fees arising out of, directly or indirectly, any claim of personal injury or death associated with such unintended or unauthorized use, even if such claim alleges that ON Semiconductor was negligent regarding the design or manufacture of the part. ON Semiconductor is an Equal Opportunity/Affirmative Action Employer. This literature is subject to all applicable copyright laws and is not for resale in any manner.



74VCX163245

Low Voltage 16-Bit Dual Supply Translating Transceiver with 3-STATE Outputs

Features

- Bidirectional interface between busses ranging from 1.65V to 3.6V
- Supports Live Insertion and Withdrawal⁽¹⁾
- Static Drive (I_{OH}/I_{OL})
 - $\pm 24\text{mA}$ @ 3.0V V_{CC}
 - $\pm 18\text{mA}$ @ 2.3V V_{CC}
 - $\pm 6\text{mA}$ @ 1.65V V_{CC}
- Uses proprietary Quiet Series™ noise/EMI reduction circuitry
- Functionally compatible with 74 series 16245
- Latchup performance exceeds 300mA
- ESD performance:
 - Human Body Model >2000V
 - Machine model >200V
- Also packaged in plastic Fine-Pitch Ball Grid Array (FBGA)

Note:

1. To ensure the high impedance state during power up or power down, OE_n should be tied to V_{CCB} through a pull up resistor. The minimum value of the resistor is determined by the current sourcing capability of the driver.

General Description

The VCX163245 is a dual supply, 16-bit translating transceiver that is designed for 2 way asynchronous communication between busses at different supply voltages by providing true signal translation. The supply rails consist of V_{CCA} , which is a higher potential rail operating at 2.3V to 3.6V and V_{CCB} , which is the lower potential rail operating at 1.65V to 2.7V. (V_{CCB} must be less than or equal to V_{CCA} for proper device operation). This dual supply design allows for translation from 1.8V to 2.5V busses to busses at a higher potential, up to 3.3V.

The Transmit/Receive (T/\bar{R}) input determines the direction of data flow. Transmit (active-HIGH) enables data from A Ports to B Ports; Receive (active-LOW) enables data from B Ports to A Ports. The Output Enable (\overline{OE}) input, when HIGH, disables both A and B Ports by placing them in a High-Z condition. The A Port interfaces with the higher voltage bus (2.7V to 3.3V); The B Port interfaces with the lower voltage bus (1.8V to 2.5V). Also the VCX163245 is designed so that the control pins (T/\bar{R}_n , \overline{OE}_n) are supplied by V_{CCB} .

The 74VCX163245 is suitable for mixed voltage applications such as notebook computers using a 1.8V CPU and 3.3V peripheral components. It is fabricated with an Advanced CMOS technology to achieve high speed operation while maintaining low CMOS power dissipation.

Ordering Information

Order Number	Package Number	Package Description
74VCX163245G ⁽²⁾⁽³⁾	BGA54A	54-Ball Fine-Pitch Ball Grid Array (FBGA), JEDEC MO-205, 5.5mm Wide
74VCX163245MTD ⁽³⁾	MTD48	48-Lead Thin Shrink Small Outline Package (TSSOP), JEDEC MO-153, 6.1mm Wide

Notes:

2. Ordering code "G" indicates Trays.
3. Device also available in Tape and Reel. Specify by appending the suffix letter "X" to the ordering code.

Quiet Series™ is a trademark of Fairchild Semiconductor Corporation.

Connection Diagram

Pin Assignment for TSSOP

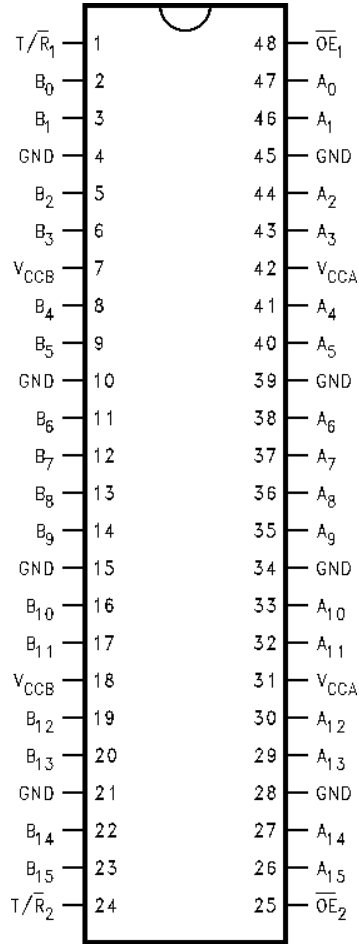

Pin Assignment for FBGA

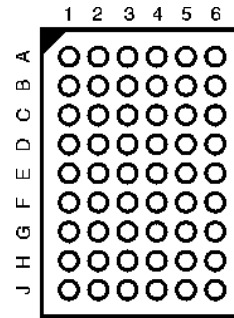

(Top Thru View)

FBGA Pin Assignments

	1	2	3	4	5	6
A	B_0	NC	$\overline{T/R}_1$	\overline{OE}_1	NC	A_0
B	B_2	B_1	NC	NC	A_1	A_2
C	B_4	B_3	V_{CCB}	V_{CCA}	A_3	A_4
D	B_6	B_5	GND	GND	A_5	A_6
E	B_8	B_7	GND	GND	A_7	A_8
F	B_{10}	B_9	GND	GND	A_9	A_{10}
G	B_{12}	B_{11}	V_{CCB}	V_{CCA}	A_{11}	A_{12}
H	B_{14}	B_{13}	NC	NC	A_{13}	A_{14}
J	B_{15}	NC	$\overline{T/R}_2$	\overline{OE}_2	NC	A_{15}

Pin Descriptions

Pin Names	Description
\overline{OE}_n	Output Enable Input (Active LOW)
$\overline{T/R}_n$	Transmit/Receive Input
A_0 - A_{15}	Side A Inputs or 3-STATE Outputs
B_0 - B_{15}	Side B Inputs or 3-STATE Outputs
NC	No Connect

Logic Diagram

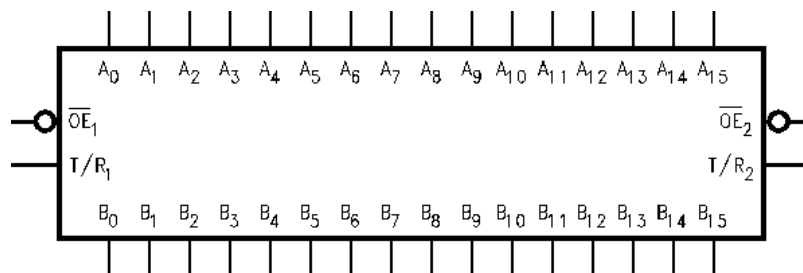

Truth Tables

Inputs		Outputs
\overline{OE}_1	T/\overline{R}_1	
L	L	Bus B ₀ -B ₇ Data to Bus A ₀ -A ₇
L	H	Bus A ₀ -A ₇ Data to Bus B ₀ -B ₇
H	X	HIGH Z State on A ₀ -A ₇ , B ₀ -B ₇

Inputs		Outputs
\overline{OE}_2	T/\overline{R}_2	
L	L	Bus B ₈ -B ₁₅ Data to Bus A ₈ -A ₁₅
L	H	Bus A ₈ -A ₁₅ Data to Bus B ₈ -B ₁₅
H	X	HIGH-Z State on A ₈ -A ₁₅ , B ₈ -B ₁₅

H = HIGH Voltage Level

L = LOW Voltage Level

X = Immaterial (HIGH or LOW, inputs may not float)

Z = High Impedance

VCX163245 Translator Power Up Sequence Recommendations

To guard against power up problems, some simple guidelines need to be adhered to. The VCX163245 is designed so that the control pins (T/\overline{R}_n , \overline{OE}_n) are supplied by V_{CCB} . Therefore the first recommendation is to begin by powering up the control side of the device, V_{CCB} . The \overline{OE}_n control pins should be ramped with or ahead of V_{CCB} , this will guard against bus contentions and oscillations as all A Port and B Port outputs will be disabled. To ensure the high impedance state during power up or power down, \overline{OE}_n should be tied to V_{CCB} through a pull up resistor. The minimum value of the resistor is determined by the current sourcing capability of the driver. Second, the T/\overline{R}_n control pins should be

placed at logic LOW (0V) level, this will ensure that the B-side bus pins are configured as inputs to help guard against bus contention and oscillations. B-side Data Inputs should be driven to a valid logic level (0V or V_{CCB}), this will prevent excessive current draw and oscillations. V_{CCA} can then be powered up after V_{CCB} , however V_{CCA} must be greater than or equal to V_{CCB} to ensure proper device operation. Upon completion of these steps the device can then be configured for the users desired operation. Following these steps will help to prevent possible damage to the translator device as well as other system components.

Logic Diagrams

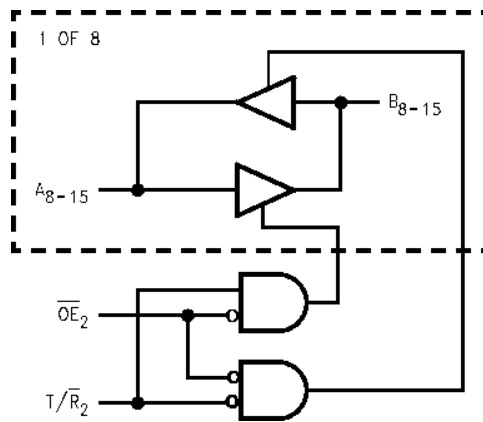
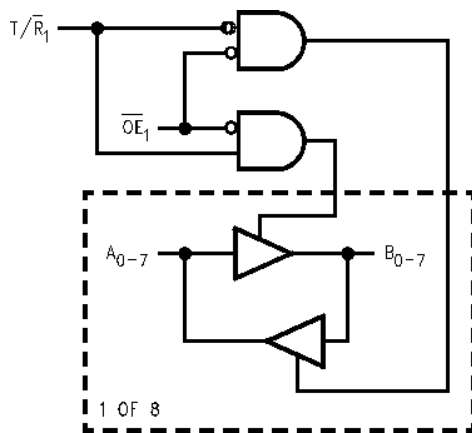

Please note that these diagrams are provided only for the understanding of logic operations and should not be used to estimate propagation delays.

Absolute Maximum Ratings

Stresses exceeding the absolute maximum ratings may damage the device. The device may not function or be operable above the recommended operating conditions and stressing the parts to these levels is not recommended. In addition, extended exposure to stresses above the recommended operating conditions may affect device reliability. The absolute maximum ratings are stress ratings only.

Symbol	Parameter	Rating
V_{CCA}	Supply Voltage	-0.5V to +4.6V
V_{CCB}		-0.5V to V_{CCA}
V_I	DC Input Voltage	-0.5V to +4.6V
$V_{I/O}$	DC Output Voltage Outputs 3-STATE A_n Output Active ⁽⁴⁾ B_n Output Active ⁽⁴⁾	-0.5V to +4.6V -0.5V to $V_{CCA} + 0.5V$ -0.5V to $V_{CCB} + 0.5V$
I_{IK}	DC Input Diode Current, $V_I < 0V$	-50mA
I_{OK}	DC Output Diode Current $V_O < 0V$ $V_O > V_{CC}$	-50mA +50mA
I_{OH}/I_{OL}	DC Output Source/Sink Current	±50mA
	DC V_{CC} or Ground Current	±100mA
I_{CC} or Ground	Supply Pin	
T_{STG}	Storage Temperature	-65°C to +150°C

Recommended Operating Conditions⁽⁵⁾

The Recommended Operating Conditions table defines the conditions for actual device operation. Recommended operating conditions are specified to ensure optimal performance to the datasheet specifications. Fairchild does not recommend exceeding them or designing to absolute maximum ratings.

Symbol	Parameter	Rating
V_{CCA}	Power Supply ⁽⁶⁾	2.3V to 3.6V
V_{CCB}		1.65V to 2.7V
V_I	Input Voltage () @ \overline{OE} , T/\overline{R}	0V to V_{CCB}
$V_{I/O}$	Input/Output Voltage () A_n B_n	0V to V_{CCA} 0V to V_{CCB}
I_{OH}/I_{OL}	Output Current in I_{OH}/I_{OL} $V_{CCA} = 3.0V$ to 3.6V $V_{CCA} = 2.3V$ to 2.7V $V_{CCB} = 2.3V$ to 2.7V $V_{CCB} = 1.65V$ to 1.95V	±24mA ±18mA ±18mA ±6mA
T_A	Free Air Operating Temperature	-40°C to +85°C
$\Delta t/\Delta V$	Minimum Input Edge Rate, $V_{IN} = 0.8V$ to 2.0V, $V_{CC} = 3.0V$	10ns/V

Notes:

- I_O Absolute Maximum Rating must be observed.
- Unused inputs or I/O pins must be held HIGH or LOW. They may not float.
- Operation requires: $V_{CCB} \leq V_{CCA}$

DC Electrical Characteristics ($1.65V < V_{CCB} \leq 1.95V$, $2.3V < V_{CCA} \leq 2.7V$)

Symbol	Parameter	V_{CCB} (V)	V_{CCA} (V)	Conditions	Min.	Max.	Units
V_{IHA}	HIGH Level Input Voltage	A_n	1.65–1.95	2.3–2.7		1.6	V
V_{IHB}		$B_n, \overline{T/R}, \overline{OE}$	1.65–1.95	2.3–2.7		$0.65 \times V_{CCB}$	V
V_{ILA}	LOW Level Input Voltage	A_n	1.65–1.95	2.3–2.7		0.7	V
V_{ILB}		$B_n, \overline{T/R}, \overline{OE}$	1.65–1.95	2.3–2.7		$0.35 \times V_{CCB}$	V
V_{OHA}	HIGH Level Output Voltage		1.65–1.95	2.3–2.7	$I_{OH} = -100\mu A$	$V_{CCA} - 0.2$	V
			1.65	2.3–2.7	$I_{OH} = -18mA$	1.7	
V_{OHB}	HIGH Level Output Voltage		1.65–1.95	2.3–2.7	$I_{OH} = -100\mu A$	$V_{CCB} - 0.2$	V
			1.65–1.95	2.3	$I_{OH} = -6mA$	1.25	
V_{OLA}	Low Level Output Voltage		1.65–1.95	2.3–2.7	$I_{OL} = 100\mu A$	0.2	V
			1.65	2.3–2.7	$I_{OL} = 18mA$	0.6	
V_{OLB}	Low Level Output Voltage		1.65–1.95	2.3–2.7	$I_{OL} = 100\mu A$	0.2	V
			1.65–1.95	2.3	$I_{OL} = 6mA$	0.3	
I_I	Input Leakage Current @ \overline{OE} , $\overline{T/R}$	1.65–1.95	2.3–2.7	$0V \leq V_I \leq 3.6V$		± 5.0	μA
I_{OZ}	3-STATE Output Leakage	1.65–1.95	2.3–2.7	$0V \leq V_O \leq 3.6V$, $\overline{OE} = V_{CCB}$, $V_I = V_{IH}$ or V_{IL}		± 10	μA
I_{OFF}	Power Off Leakage Current	0	0	$0 \leq (V_I, V_O) \leq 3.6V$		10	μA
I_{CCA}/I_{CCB}	Quiescent Supply Current, per supply, V_{CCA} / V_{CCB}		1.65–1.95	2.3–2.7	$A_n = V_{CCA}$ or GND, B_n, \overline{OE} , & $\overline{T/R} = V_{CCB}$ or GND	20	μA
			1.65–1.95	2.3–2.7	$V_{CCA} \leq A_n \leq 3.6V$, $V_{CCB} \leq B_n, \overline{OE}$, $\overline{T/R} \leq 3.6V$	± 20	μA
ΔI_{CC}	Increase in I_{CC} per Input, $B_n, \overline{T/R}, \overline{OE}$	1.65–1.95	2.3–2.7	$V_I = V_{CCB} - 0.6V$		750	μA
	Increase in I_{CC} per Input, A_n	1.65–1.95	2.3–2.7	$V_I = V_{CCA} - 0.6V$		750	μA

DC Electrical Characteristics ($1.65V < V_{CCB} \leq 1.95V$, $3.0V < V_{CCA} \leq 3.6V$)

Symbol	Parameter	V_{CCB} (V)	V_{CCA} (V)	Conditions	Min.	Max.	Units
V_{IHA}	HIGH Level Input Voltage	A_n	1.65–1.95	3.0–3.6		2.0	V
V_{IHB}		$B_n, \overline{T/R}, \overline{OE}$	1.65–1.95	3.0–3.6		$0.65 \times V_{CCB}$	V
V_{ILA}	LOW Level Input Voltage	A_n	1.65–1.95	3.0–3.6		0.8	V
V_{ILB}		$B_n, \overline{T/R}, \overline{OE}$	1.65–1.95	3.0–3.6		$0.35 \times V_{CCB}$	V
V_{OHA}	HIGH Level Output Voltage		1.65–1.95	3.0–3.6	$I_{OH} = -100\mu A$	$V_{CCA} - 0.2$	V
			1.65	3.0–3.6	$I_{OH} = -24mA$	2.2	
V_{OHB}	HIGH Level Output Voltage		1.65–1.95	3.0–3.6	$I_{OH} = -100\mu A$	$V_{CCA} - 0.2$	V
			1.65–1.95	3.0	$I_{OH} = -6mA$	1.25	
V_{OLA}	LOW Level Output Voltage		1.65–1.95	3.0–3.6	$I_{OL} = 100\mu A$	0.2	V
			1.65	3.0–3.6	$I_{OL} = 24mA$	0.55	
V_{OLB}	LOW Level Output Voltage		1.65–1.95	3.0–3.6	$I_{OL} = 100\mu A$	0.2	V
			1.65–1.95	3.0	$I_{OL} = 6mA$	0.3	
I_I	Input Leakage Current @ \overline{OE} , $\overline{T/R}$	1.65–1.95	3.0–3.6	$0V \leq V_I \leq 3.6V$		± 5.0	μA
I_{OZ}	3-STATE Output Leakage	1.65–1.95	3.0–3.6	$0V \leq V_O \leq 3.6V$, $\overline{OE} = V_{CCB}$, $V_I = V_{IH}$ or V_{IL}		± 10	μA
I_{OFF}	Power OFF Leakage Current	0	0	$0 \leq (V_I, V_O) \leq 3.6V$		10	μA
I_{CCA}/I_{CCB}	Quiescent Supply Current, per supply, V_{CCA}/V_{CCB}		1.65–1.95	3.0–3.6	$A_n = V_{CCA}$ or GND, B_n, \overline{OE} , & $\overline{T/R} = V_{CCB}$ or GND	20	μA
			1.65–1.95	3.0–3.6	$V_{CCA} \leq A_n \leq 3.6V$, $V_{CCB} \leq B_n, \overline{OE}$, $\overline{T/R} \leq 3.6V$	± 20	
ΔI_{CC}	Increase in I_{CC} per Input, B_n , $\overline{T/R}$, \overline{OE} ,	1.65–1.95	3.0–3.6	$V_I = V_{CCB} - 0.6V$		750	μA
	Increase in I_{CC} per Input, A_n	1.65–1.95	3.0–3.6	$V_I = V_{CCA} - 0.6V$		750	

DC Electrical Characteristics ($2.3V < V_{CCB} \leq 2.7V$, $3.0V \leq V_{CCA} \leq 3.6V$)

Symbol	Parameter	V_{CCB} (V)	V_{CCA} (V)	Conditions	Min.	Max.	Units
V_{IHA}	HIGH Level Input Voltage	A_n	2.3–2.7	3.0–3.6		2.0	V
V_{IHB}		$B_n, T/\bar{R}, \overline{OE}$	2.3–2.7	3.0–3.6		1.6	V
V_{ILA}	LOW Level Input Voltage	A_n	2.3–2.7	3.0–3.6		0.8	V
V_{ILB}		$B_n, T/\bar{R}, \overline{OE}$	2.3–2.7	3.0–3.6		0.7	V
V_{OHA}	HIGH Level Output Voltage		2.3–2.7	3.0–3.6	$I_{OH} = -100\mu A$	$V_{CCA} - 0.2$	V
			2.3	3.0–3.6	$I_{OH} = -24mA$	2.2	
V_{OHB}	HIGH Level Output Voltage		2.3–2.7	3.0–3.6	$I_{OH} = -100\mu A$	$V_{CCB} - 0.2$	V
			2.3–2.7	3.0	$I_{OH} = -18mA$	1.7	
V_{OLA}	LOW Level Output Voltage		2.3–2.7	3.0–3.6	$I_{OL} = 100\mu A$	0.2	V
			2.3	3.0–3.6	$I_{OL} = 24mA$	0.55	
V_{OLB}	LOW Level Output Voltage		2.3–2.7	3.0–3.6	$I_{OL} = 100\mu A$	0.2	V
			2.3–2.7	3.0	$I_{OL} = 18mA$	0.6	
I_I	Input Leakage Current @ \overline{OE} , T/\bar{R}	2.3–2.7	3.0–3.6	$0V \leq V_I \leq 3.6V$		± 5.0	μA
I_{OZ}	3-STATE Output Leakage @ A_n	2.3–2.7	3.0–3.6	$0V \leq V_O \leq 3.6V$, $\overline{OE} = V_{CCA}$, $V_I = V_{IH}$ or V_{IL}		± 10	μA
I_{OFF}	Power OFF Leakage Current	0	0	$0 \leq (V_I, V_O) \leq 3.6V$		10	μA
I_{CCA}/I_{CCB}	Quiescent Supply Current, per supply, V_{CCA}/V_{CCB}		2.3–2.7	3.0–3.6	$A_n = V_{CCA}$ or GND, B_n, \overline{OE} , & $T/\bar{R} = V_{CCB}$ or GND	20	μA
			2.3–2.7	3.0–3.6	$V_{CCA} \leq A_n \leq 3.6V$, $V_{CCB} \leq B_n, \overline{OE}$, $T/\bar{R} \leq 3.6V$	± 20	μA
ΔI_{CC}	Increase in I_{CC} per Input, $B_n, T/\bar{R}, \overline{OE}$	2.3–2.7	3.0–3.6	$V_I = V_{CCB} - 0.6V$		750	μA
	Increase in I_{CC} per Input, A_n	2.3–2.7	3.0–3.6	$V_I = V_{CCA} - 0.6V$		750	μA

AC Electrical Characteristics

Symbol	Parameter	$T_A = -40^{\circ}\text{C to } +85^{\circ}\text{C}, C_L = 30\text{ pF}, R_L = 500\Omega$						Units
		$V_{CCB} = 1.65\text{V to } 1.95\text{V}, V_{CCA} = 2.3\text{V to } 2.7\text{V}$		$V_{CCB} = 1.65\text{V to } 1.95\text{V}, V_{CCA} = 3.0\text{V to } 3.6\text{V}$		$V_{CCB} = 2.3\text{V to } 2.7\text{V}, V_{CCA} = 3.0\text{V to } 3.6\text{V}$		
		Min.	Max.	Min.	Max.	Min.	Max.	
t_{PHL}, t_{PLH}	Propagation Delay, A to B	1.5	5.8	1.5	6.2	0.8	4.4	ns
t_{PHL}, t_{PLH}	Propagation Delay, B to A	0.8	5.5	0.6	5.1	0.6	4.0	ns
t_{PZL}, t_{PZH}	Output Enable Time, OE to B	1.5	8.3	1.5	8.2	0.8	4.6	ns
t_{PZL}, t_{PZH}	Output Enable Time, OE to A	0.8	5.3	0.6	5.1	0.6	4.0	ns
t_{PLZ}, t_{PHZ}	Output Disable Time, OE to B	0.8	4.6	0.8	4.5	0.8	4.4	ns
t_{PLZ}, t_{PHZ}	Output Disable Time, OE to A	0.8	5.2	0.6	5.6	0.6	4.8	ns
t_{osHL}, t_{osLH}	Output to Output Skew ⁽⁷⁾		0.05		0.5		0.75	ns

Note:

7. Skew is defined as the absolute value of the difference between the actual propagation delay for any two separate outputs of the same device. The specification applies to any outputs switching in the same direction, either HIGH-to-LOW (t_{osHL}) or LOW-to-HIGH (t_{osLH}).

Dynamic Switching Characteristics

Symbol	Parameter	V_{CCB} (V)	V_{CCA} (V)	Conditions	$T_A = +25^{\circ}\text{C}$ Typical	Units
V_{OLP}	Quiet Output Dynamic Peak V_{OL} , A to B	1.8	2.5	$C_L = 30\text{ pF}, V_{IH} = V_{CC}, V_{IL} = 0\text{V}$	0.25	V
		1.8	3.3		0.25	
		2.5	3.3		0.6	
V_{OLP}	Quiet Output Dynamic Peak V_{OL} , B to A	1.8	2.5	$C_L = 30\text{ pF}, V_{IH} = V_{CC}, V_{IL} = 0\text{V}$	0.6	V
		1.8	3.3		0.8	
		2.5	3.3		0.8	
V_{OLV}	Quiet Output Dynamic Valley V_{OL} , A to B	1.8	2.5	$C_L = 30\text{ pF}, V_{IH} = V_{CC}, V_{IL} = 0\text{V}$	-0.25	V
		1.8	3.3		-0.25	
		2.5	3.3		-0.6	
V_{OLV}	Quiet Output Dynamic Valley V_{OL} , B to A	1.8	2.5	$C_L = 30\text{ pF}, V_{IH} = V_{CC}, V_{IL} = 0\text{V}$	-0.6	V
		1.8	3.3		-0.8	
		2.5	3.3		-0.8	
V_{OHV}	Quiet Output Dynamic Valley V_{OH} , A to B	1.8	2.5	$C_L = 30\text{ pF}, V_{IH} = V_{CC}, V_{IL} = 0\text{V}$	1.3	V
		1.8	3.3		1.3	
		2.5	3.3		1.7	
V_{OHV}	Quiet Output Dynamic Valley V_{OH} , B to A	1.8	2.5	$C_L = 30\text{ pF}, V_{IH} = V_{CC}, V_{IL} = 0\text{V}$	1.7	V
		1.8	3.3		2.0	
		2.5	3.3		2.0	

Capacitance

Symbol	Parameter	Conditions	T _A = +25°C	Units
C _{IN}	Input Capacitance	V _{CCB} = 2.5V, V _{CCA} = 3.3V, V _I = 0V or V _{CCA/B}	5	pF
C _{I/O}	Input/Output Capacitance	V _{CCB} = 2.5V, V _{CCA} = 3.3V, V _I = 0V or V _{CCA/B}	6	pF
C _{PD}	Power Dissipation Capacitance	V _{CCB} = 2.5V, V _{CCA} = 3.3V, V _I = 0V or V _{CCA/B} , f = 10MHz	20	pF

AC Loading and Waveforms

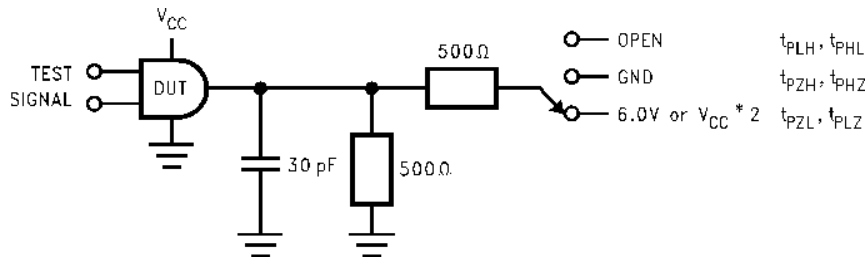

Figure 1. AC Test Circuit

Test	Switch
t _{PLH} , t _{PHL}	OPEN
t _{PZL} , t _{PLZ}	6V at V _{CC} = 3.3 ± 0.3V; V _{CC} × 2 at V _{CC} = 2.5 ± 0.2V; 1.8V ± 0.15V
t _{PZH} , t _{PHZ}	GND

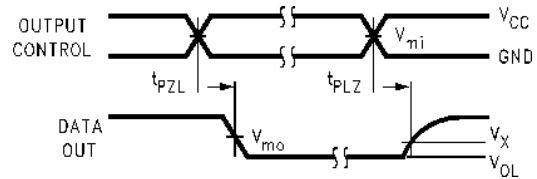

Figure 4. 3-STATE Output Low Enable and Disable Times for Low Voltage Logic
t_R = t_F ≤ 2.0 ns, 10% to 90%

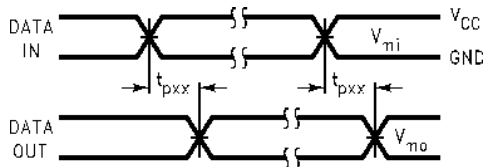

Figure 2. Waveform for Inverting and Non-inverting Functions
t_R = t_F ≤ 2.0 ns, 10% to 90%

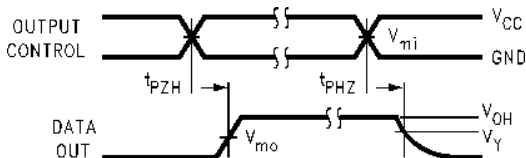

Figure 3. 3-STATE Output High Enable and Disable Times for Low Voltage Logic
t_R = t_F ≤ 2.0 ns, 10% to 90%

Symbol	V _{CC}		
	3.3V ± 0.3V	2.5V ± 0.2V	1.8V ± 0.15V
V _{mi}	1.5V	V _{CC} / 2	V _{CC} / 2
V _{mo}	1.5V	V _{CC} / 2	V _{CC} / 2
V _X	V _{OL} + 0.3V	V _{OL} + 0.15V	V _{OL} + 0.15V
V _Y	V _{OH} - 0.3V	V _{OH} - 0.15V	V _{OH} - 0.15V

Physical Dimensions

Dimensions are in millimeters unless otherwise noted.

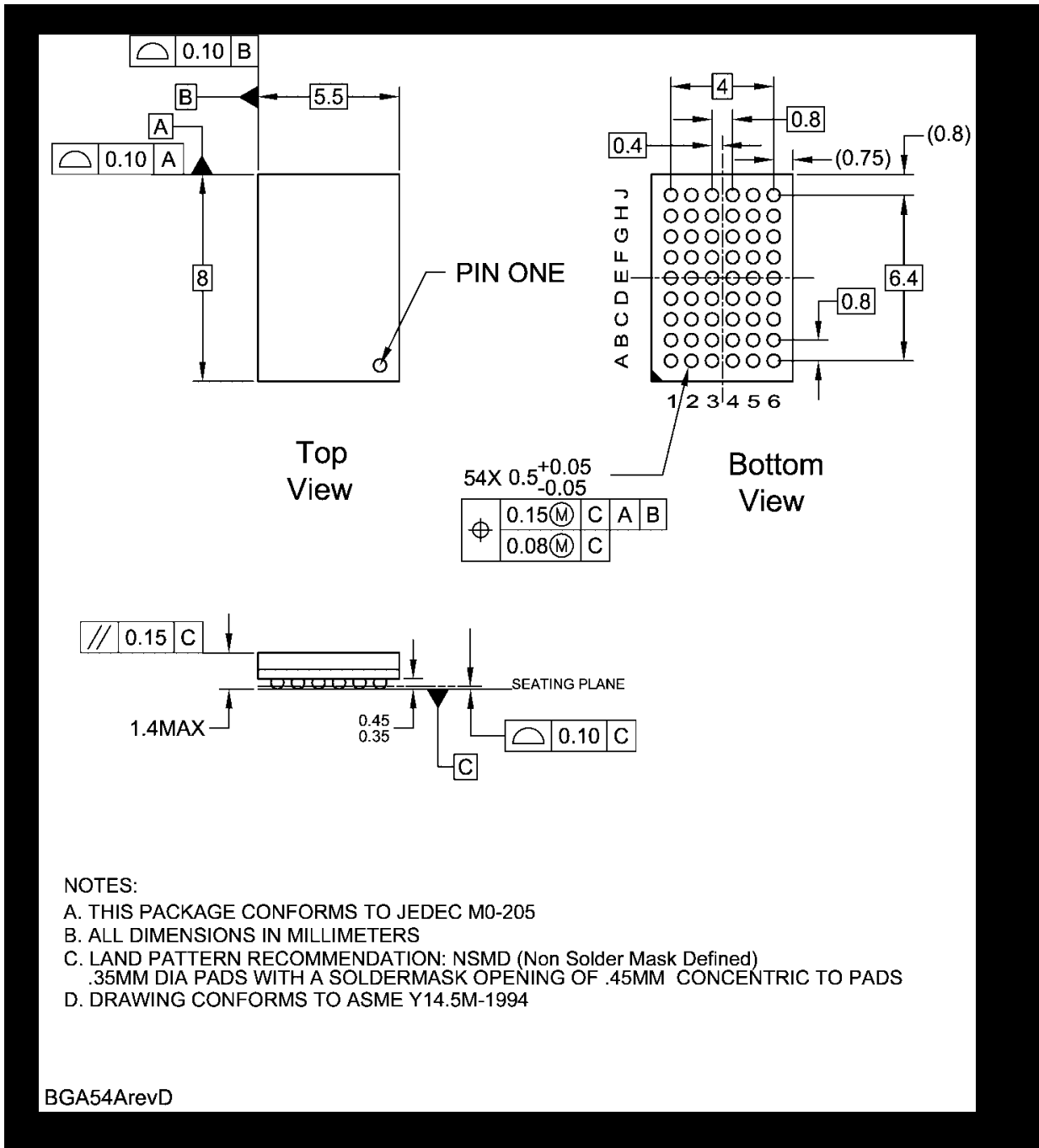

Figure 5. 54-Ball Fine-Pitch Ball Grid Array (FBGA), JEDEC MO-205, 5.5mm Wide Package Number BGA54A

Physical Dimensions (Continued)

Dimensions are in millimeters unless otherwise noted.

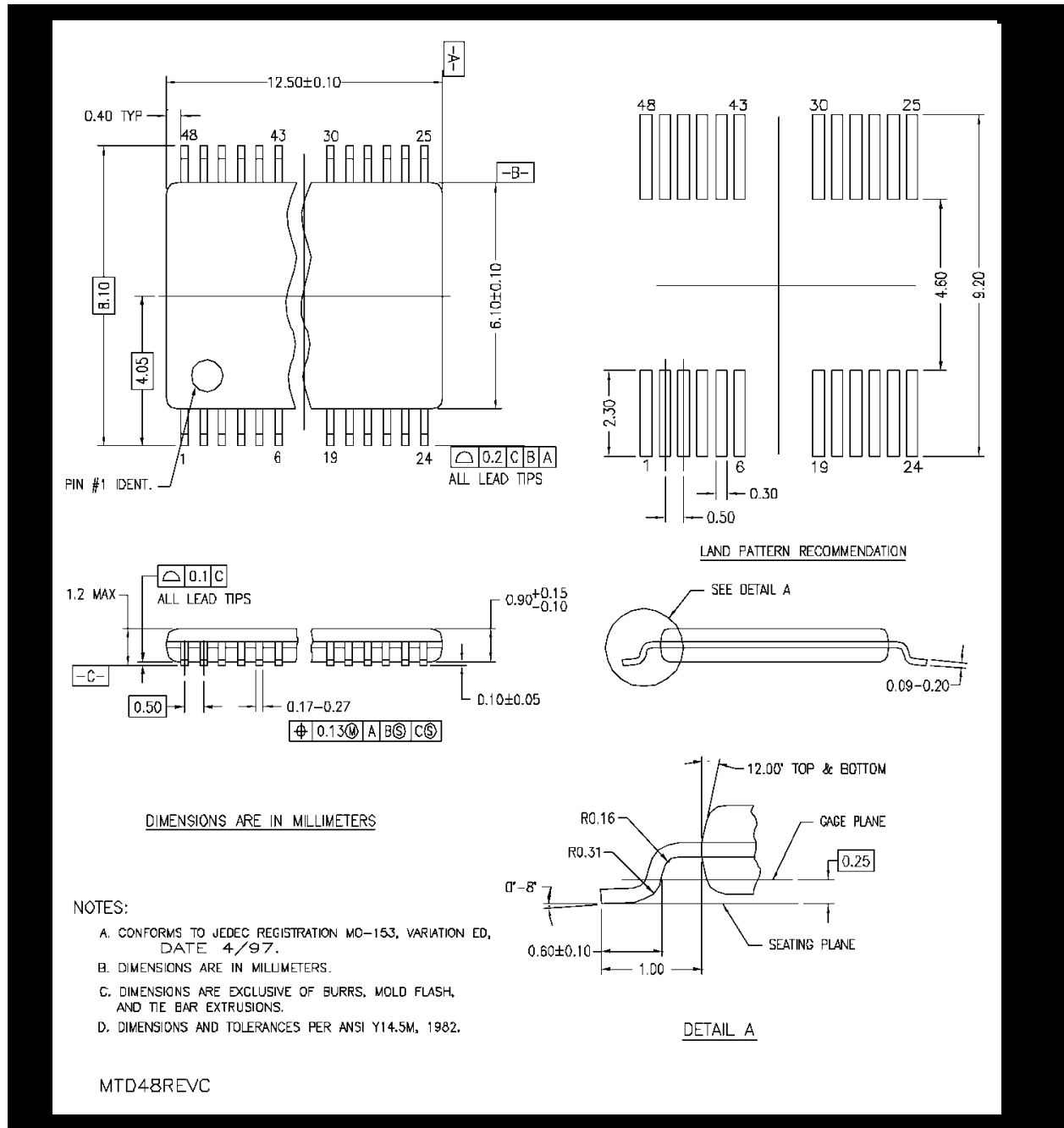

Figure 6. 48-Lead Thin Shrink Small Outline Package (TSSOP), JEDEC MO-153, 6.1mm Wide Package Number MTD48



15

ON Semiconductor and  are trademarks of Semiconductor Components Industries, LLC dba ON Semiconductor or its subsidiaries in the United States and/or other countries. ON Semiconductor owns the rights to a number of patents, trademarks, copyrights, trade secrets, and other intellectual property. A listing of ON Semiconductor's product/patent coverage may be accessed at www.onsemi.com/site/pdf/Patent-Marking.pdf. ON Semiconductor reserves the right to make changes without further notice to any products herein. ON Semiconductor makes no warranty, representation or guarantee regarding the suitability of its products for any particular purpose, nor does ON Semiconductor assume any liability arising out of the application or use of any product or circuit, and specifically disclaims any and all liability, including without limitation special, consequential or incidental damages. Buyer is responsible for its products and applications using ON Semiconductor products, including compliance with all laws, regulations and safety requirements or standards, regardless of any support or applications information provided by ON Semiconductor. "Typical" parameters which may be provided in ON Semiconductor data sheets and/or specifications can and do vary in different applications and actual performance may vary over time. All operating parameters, including "Typicals" must be validated for each customer application by customer's technical experts. ON Semiconductor does not convey any license under its patent rights nor the rights of others. ON Semiconductor products are not designed, intended, or authorized for use as a critical component in life support systems or any FDA Class 3 medical devices or medical devices with a same or similar classification in a foreign jurisdiction or any devices intended for implantation in the human body. Should Buyer purchase or use ON Semiconductor products for any such unintended or unauthorized application, Buyer shall indemnify and hold ON Semiconductor and its officers, employees, subsidiaries, affiliates, and distributors harmless against all claims, costs, damages, and expenses, and reasonable attorney fees arising out of, directly or indirectly, any claim of personal injury or death associated with such unintended or unauthorized use, even if such claim alleges that ON Semiconductor was negligent regarding the design or manufacture of the part. ON Semiconductor is an Equal Opportunity/Affirmative Action Employer. This literature is subject to all applicable copyright laws and is not for resale in any manner.

PUBLICATION ORDERING INFORMATION

LITERATURE FULFILLMENT:

Literature Distribution Center for ON Semiconductor
19521 E. 32nd Pkwy, Aurora, Colorado 80011 USA
Phone: 303-675-2175 or 800-344-3860 Toll Free USA/Canada
Fax: 303-675-2176 or 800-344-3867 Toll Free USA/Canada
Email: orderlit@onsemi.com

N. American Technical Support: 800-282-9855 Toll Free
USA/Canada
Europe, Middle East and Africa Technical Support:
Phone: 421 33 790 2910
Japan Customer Focus Center
Phone: 81-3-5817-1050

ON Semiconductor Website: www.onsemi.com
Order Literature: <http://www.onsemi.com/orderlit>
For additional information, please contact your local
Sales Representative