

NOTES:

1. RoHS COMPLIANT
2. FOR WAVESOLDERING (SOLDER BATH TEMPERATURE 260°C FOR 5 SEC. AND SOLDER PREHEAT 100° FOR 30 SEC.)
3. METALSHELLS: STEEL; min. 315µin TIN over 40-80µin NICKEL
4. INSULATORS: HIGH TEMPERATURE PLASTIC UL 94 V-0; BLACK
5. CONTACTS: COPPER ALLOY; PLATING (SEE PART NO):
 - PLEASE ADD A for GOLD FLASH over NICKEL (PREFERRED TYPE)
 - PLEASE ADD B for 20µin HARD GOLD over min. 50µin NICKEL
 - PLEASE ADD C for 30µin HARD GOLD over min. 50µin NICKEL
6. METAL BRACKETS: STEEL; min. 320µin TIN over 80µin NICKEL
7. THREADED LOCKS: COPPER ALLOY; min. 200µin TIN over 80µin NICKEL
8. PCB-SNAPS: COPPER ALLOY; min. 200µin TIN over 80µin NICKEL
PCB-HOLE: $\varnothing 3.1 \pm 0.1$; PCB THICKNESS 1.6mm
9. FIXING-PLATE: PBT GF UL 94 V-0; BLACK
10. CAPACITANCE: 1300pF $\pm 20\%$
11. DIELECTRIC WITHSTANDING VOLTAGE: 424 VDC
12. P.C.B. HOLE DRILLINGS ON SHEET 2
13. MAXIMUM TORQUE VALUE FOR THREAD: 6 in.LB
14. CONNECTOR IS PART MARKED: 241□27470X CONEC ABC

3,6^{+0,2}_{-0,6} 8,65 $\pm 0,3$ (5 : 1)

3,2 $\pm 0,2$

15,08 $\pm 0,3$

12,24 $\pm 0,3$

9,4 $\pm 0,3$

0,9

6⁺⁰_{-0,31}

11,07^{+0,13}_{-0,12}

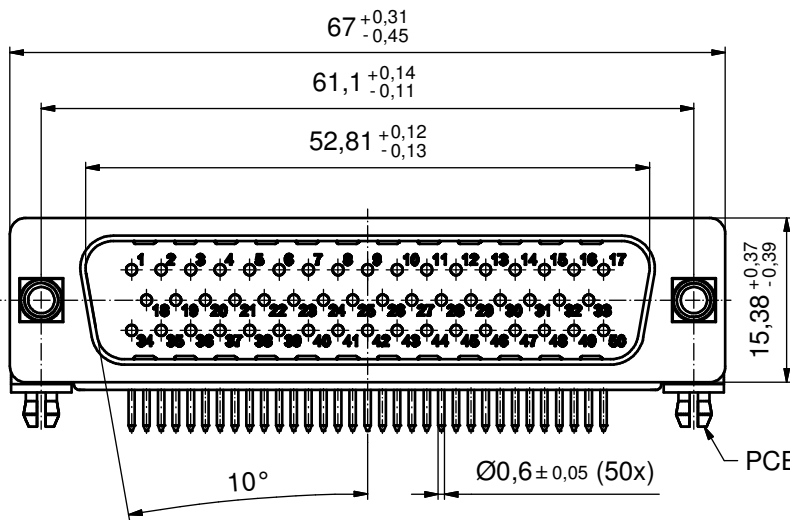

PCB SNAP

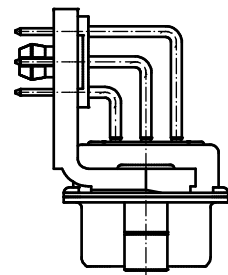
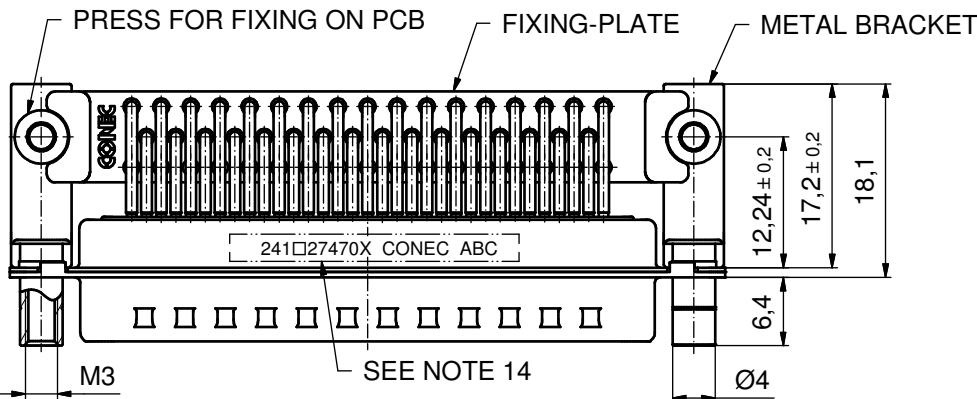
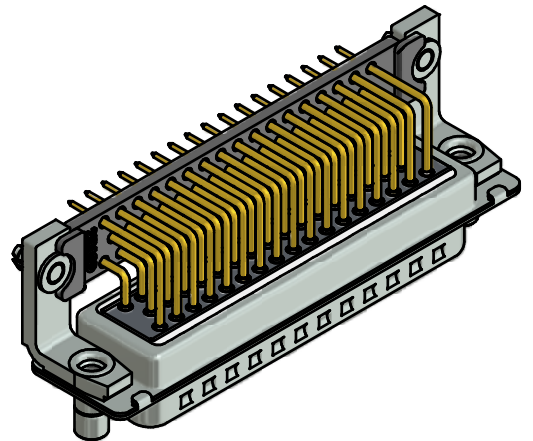

Directive 2002/95/EC RoHS compliant

THIS DRAWING MAY NOT BE COPIED OR REPRODUCED IN ANY WAY, AND MAY NOT BE PASSED ON TO A THIRD PARTY WITHOUT WRITTEN PERMISSION. OWNERSHIP AND COPYRIGHT OF CONEC GmbH DO NOT ALTER CAD DRAWING BY HAND	tolerance		dim. in mm	scale:	2:1 (5:1)
				material:	SEE NOTES
	drawn	23.04.13	Henneboel	title: D-SUB L-FILTER MALE 90° 50pos. SOLDER PIN ANGLED 0.370inch thread lock, metal bracket, fixing-plate, snap	
	appd.	25.04.13	Fischer		
	norm				
	d-old			dwg no:	
a	Original		24K1A1437		
rev.	description	date	name		DIN-A3 sh: 1/2
				part no:	241□27470X (see note 5)

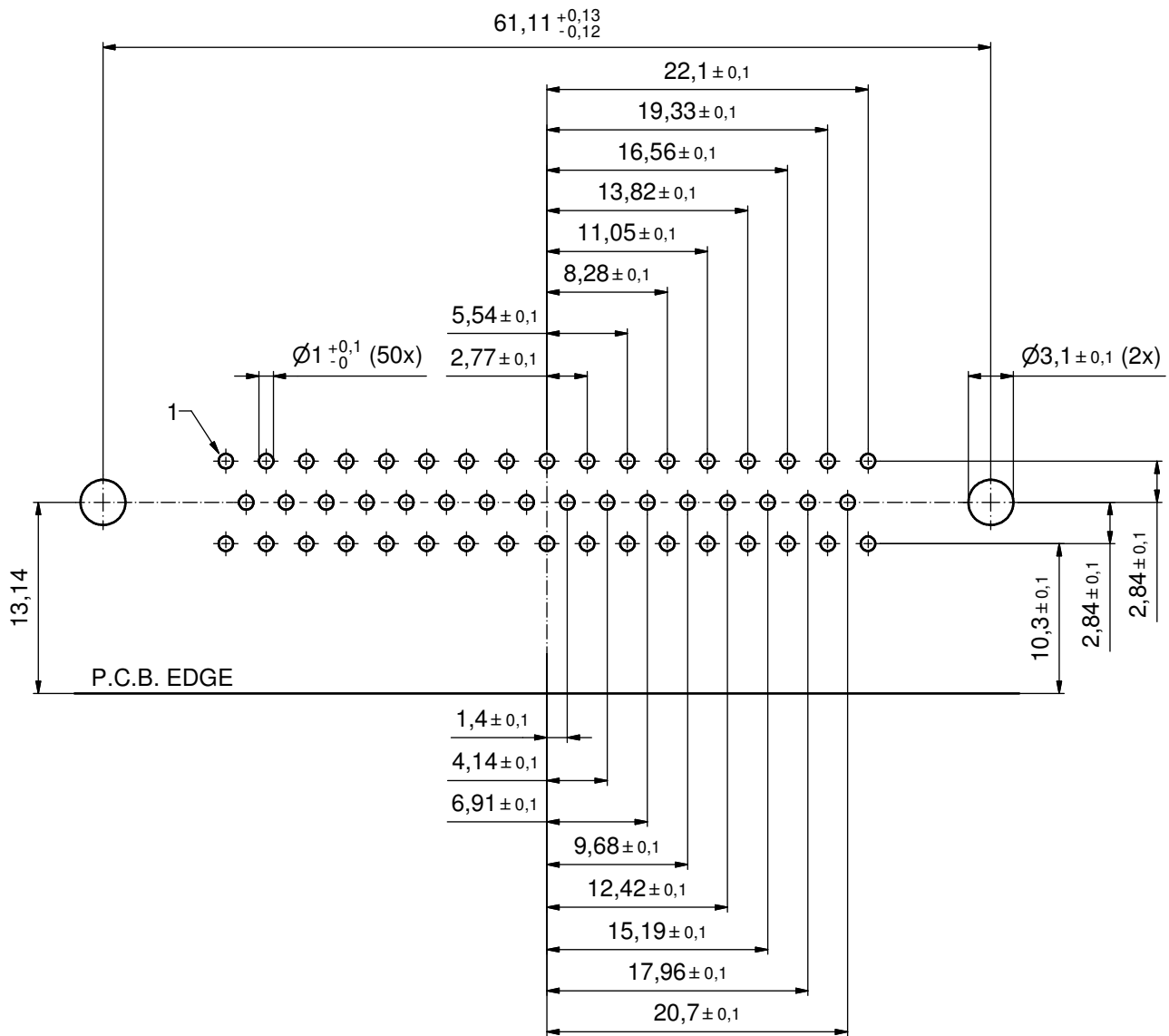

P.C.B. HOLE DRILLINGS
(P.C.B. TOP SIDE)

THIS DRAWING MAY NOT BE COPIED OR REPRODUCED IN ANY WAY, AND MAY NOT BE PASSED ON TO A THIRD PARTY WITHOUT WRITTEN PERMISSION. OWNERSHIP AND COPYRIGHT OF CONEC GmbH DO NOT ALTER CAD DRAWING BY HAND				tolerance		scale: 2:1	
				date	name	material: SEE SHEET 1	
				drawn	23.04.13	Henneboel	
				appd.	25.04.13	Fischer	
				norm			
				d-old			
	a	Original		CONEC [®]			title: P.C.B. HOLE DRILLINGS D-SUB L-FILTER MALE 90° 50pos. 0.370inch thread insert,metal bracket,fixing-plate,snap
	rev.	description	date				name
							part no: SEE SHEET 1