

LOC		DIST		REVISIONS			
A	66	P	LTM	DESCRIPTION	DATE	DMN	APVD
		-		SEE SHEET 1			

FEED TYPE MECHANICAL

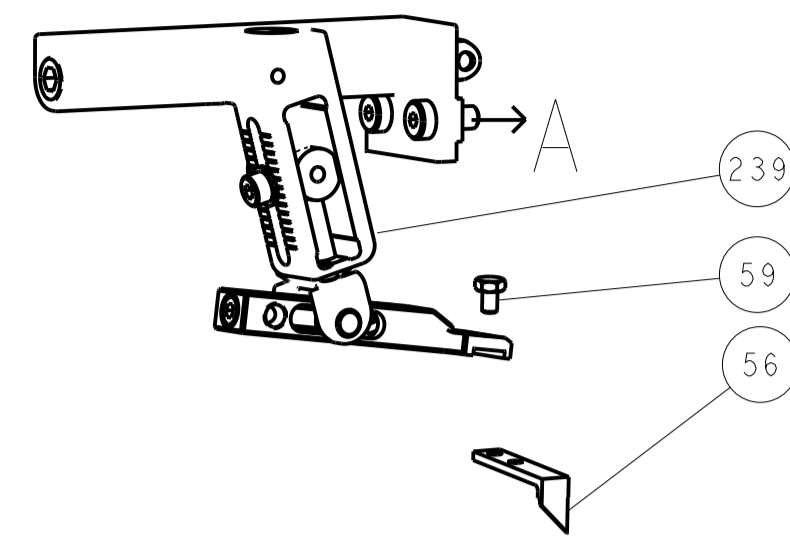

PNEUMATIC

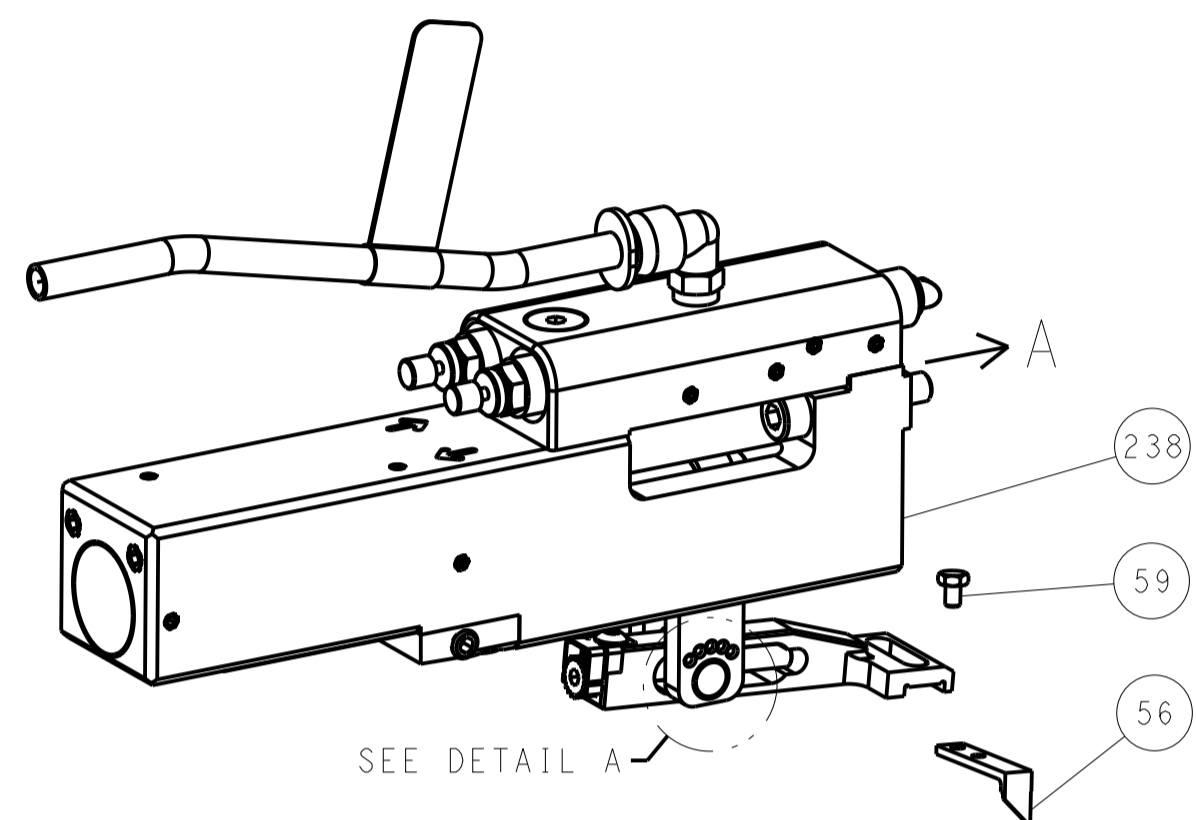

FEED SPRING SETTING POSITION (SHOWN FROM REAR SIDE)

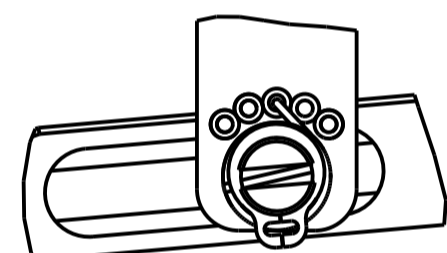

DETAIL A

DOUBLE ACTING PNEUMATIC WITH SENSORS

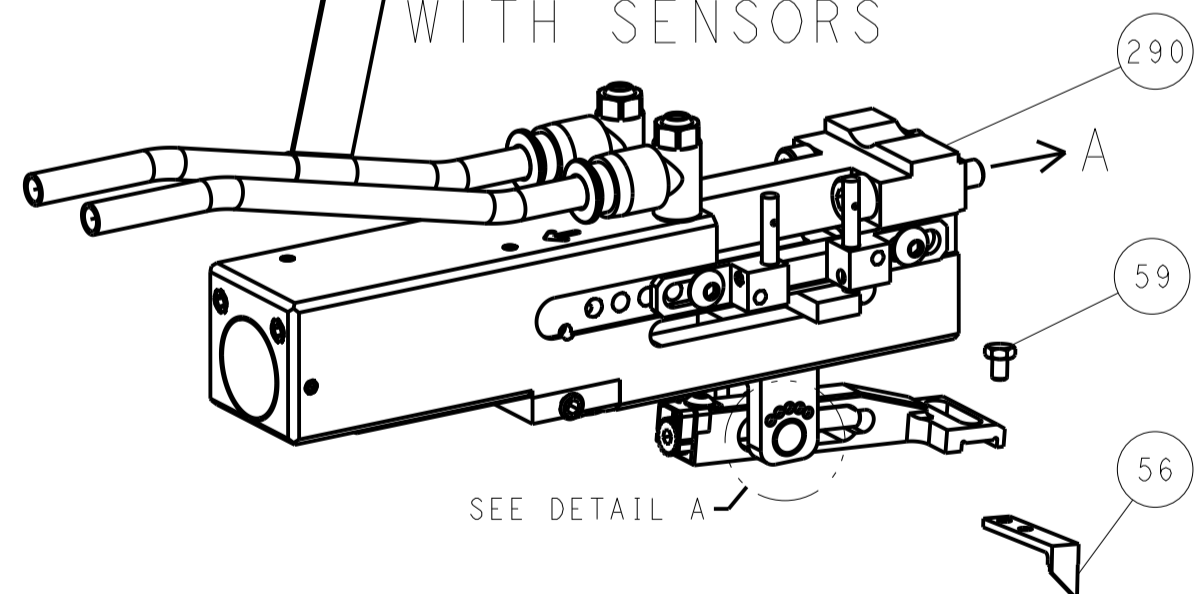

CAM POSITIONS

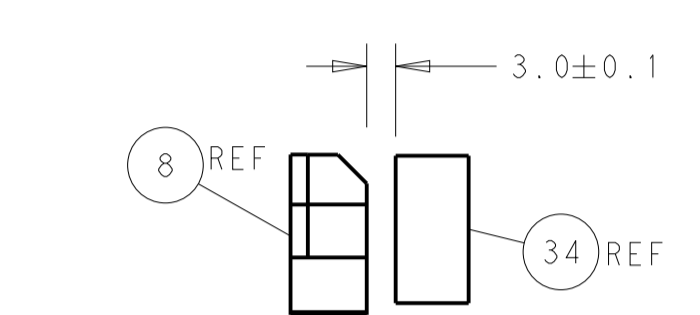
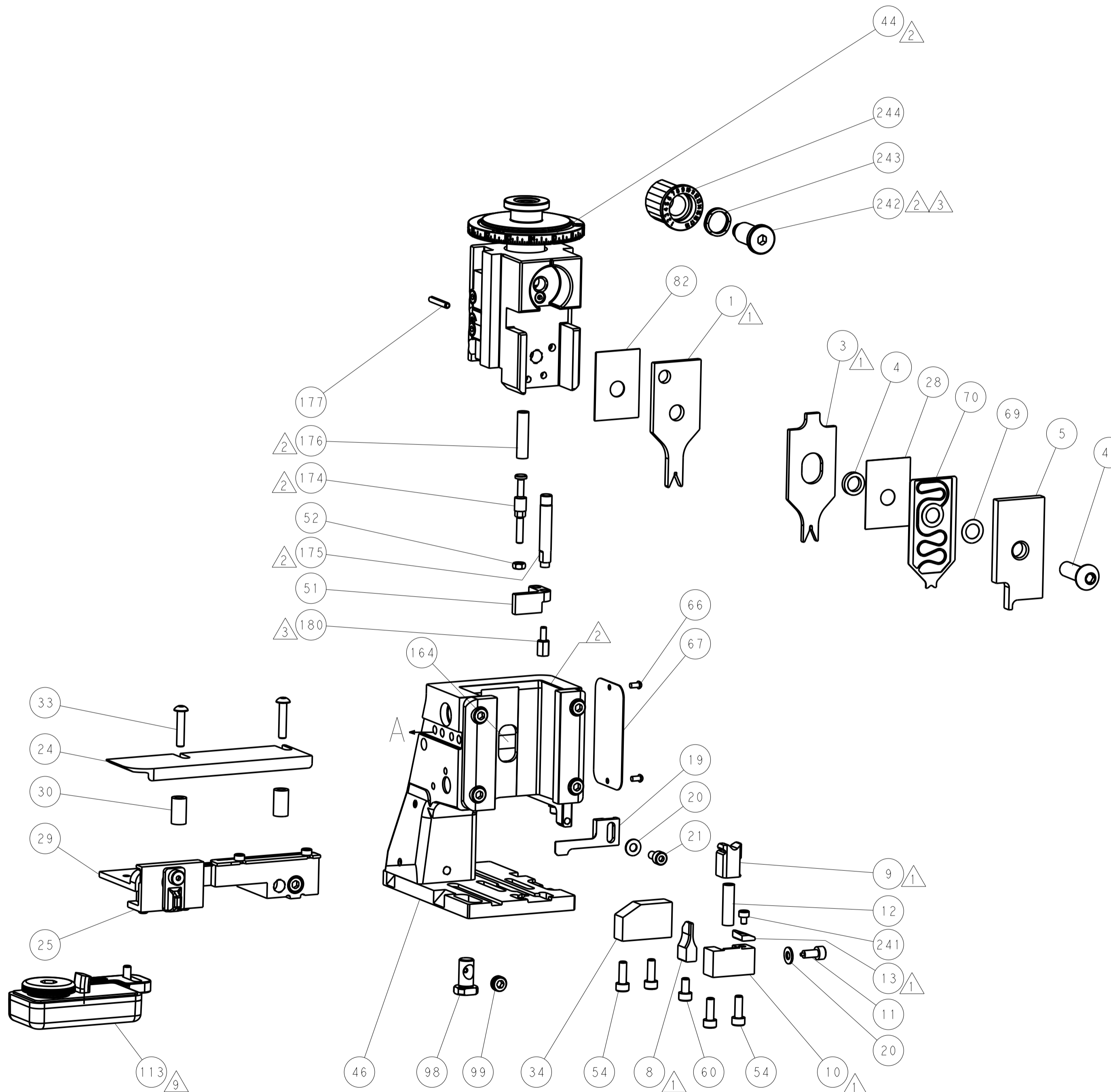
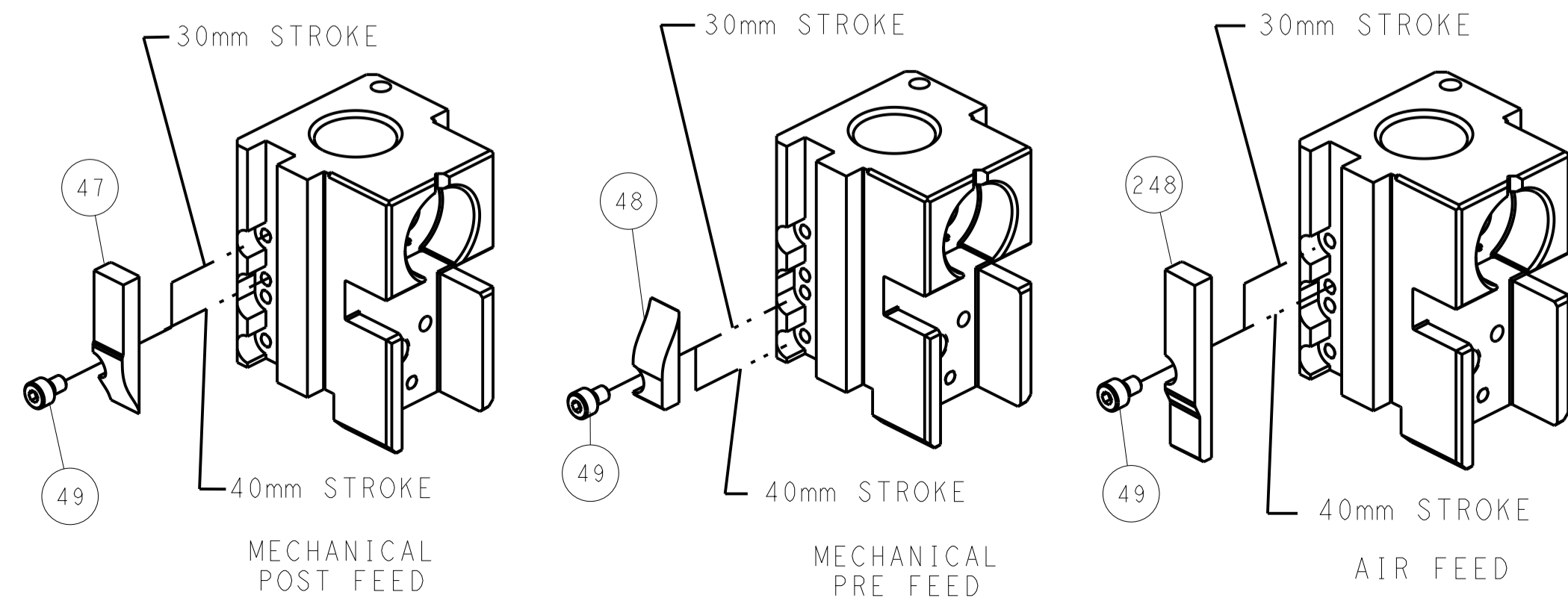

7 TERMINAL SUPPORT LOCATION

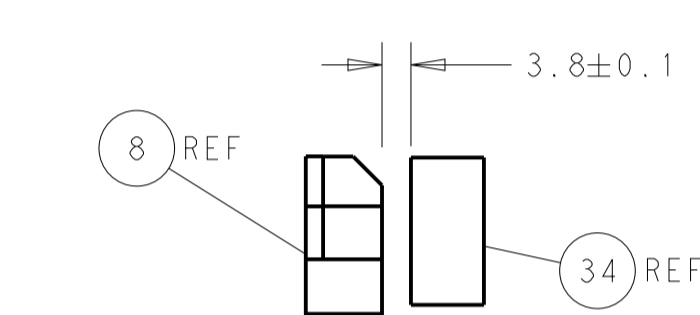

8 TERMINAL SUPPORT LOCATION

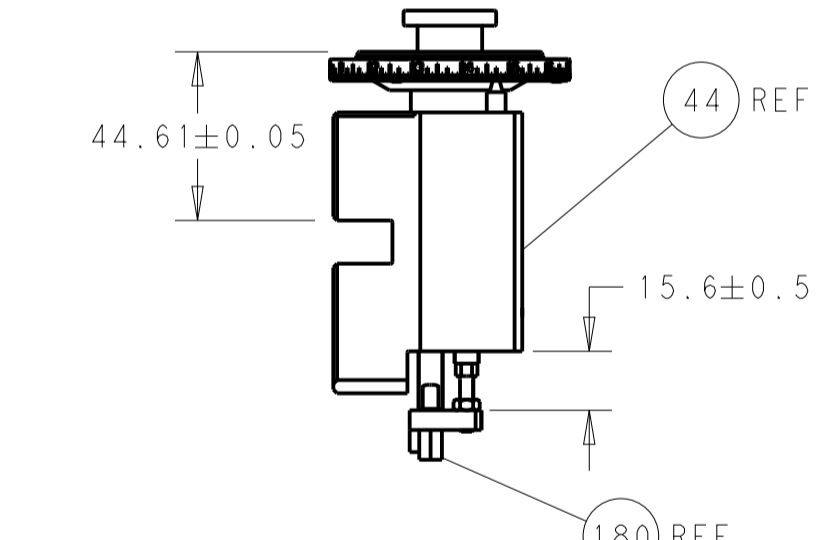

RAM AND HOLDDOWN SET-UP

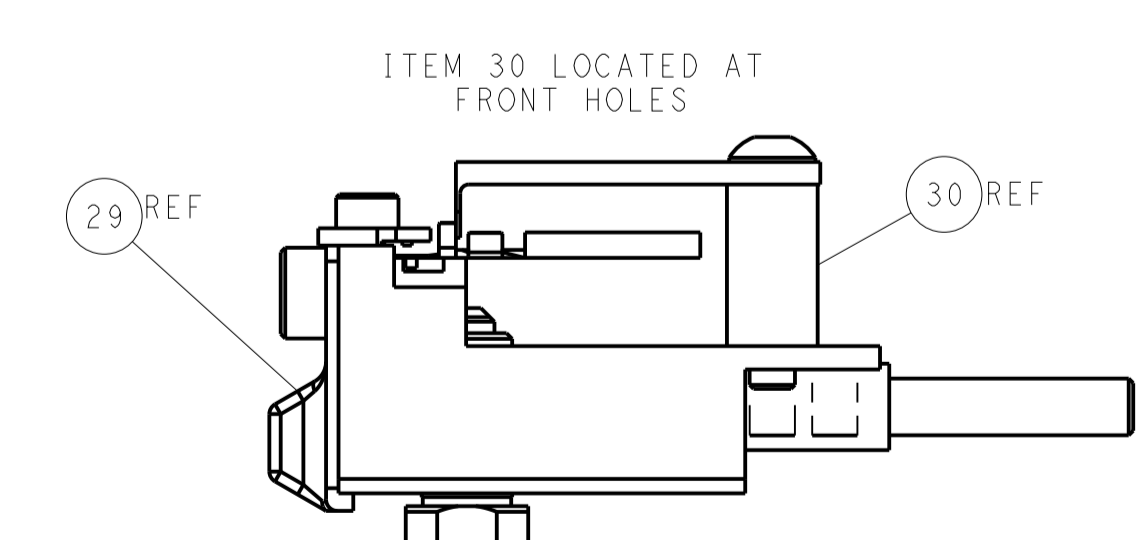

FEED TRACK POSITION GUIDE BY INSULATION BARREL

ATLANTIC VERSION
 Shown on sheets 1 of 4 & 2 of 4
 (Pacific version shown on sheets 3 of 4 & 4 of 4)

DIMENSIONS:		TOLERANCES UNLESS OTHERWISE SPECIFIED:		DWG: C. MOYER 31JUL2012		TE Connectivity	
mm	0 PLC ±	1 PLC ±	2 PLC ±	3 PLC ±	4 PLC ±	Harrisburg, PA 17105-3608	
MATERIAL:		FINISH:		CHK: T. ELBIN 31JUL2012		NAME: Ocean Side Feed Applicator	
				APVD: T. ELBIN 31JUL2012		SIZE: CAGE CODE: DRAWING NO: 00779 ©=2151725	
				PRODUCT SPEC:		RESTRICTED TO:	
				APPLICATION SPEC:		SHEET 2 OF 4 REV J2	
				WEIGHT:		SCALE: 1:2	
				CUSTOMER ACCESSIBLE PRODUCTION DRAWING		SHEETS 3 & 4 ARE NOT REQUIRED FOR ATLANTIC VERSION	

PART NUMBER	REVISION	DESCRIPTION	FEED TYPE
2-2151725-1	T	FINE CRIMP HEIGHT ADJUST	MECHANICAL
2-2151725-2	U	FINE CRIMP HEIGHT ADJUST	PNEUMATIC
4-2151725-2	U	FINE CRIMP HEIGHT ADJUST	DOUBLE ACTING PNEUMATIC WITH SENSORS
7-2151725-7	N	CRIMP TOOLING KIT	-

PACIFIC VERSION TERMINATOR INTERFACE ADAPTER

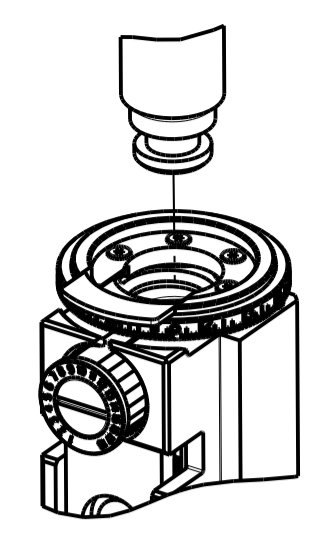

APPLICATOR DATA

CRIMP	SIZE	TYPE
WIRE	1.35 mm [.053]	F
INSUL	1.55 mm [.061]	O

APPLICATOR INSTRUCTIONS 408-35042

TERMINAL DATA: TE TERMINAL TE CRIMP SPECIFICATION

TERMINAL NAME: GENERATION Y, 0.64 STYLE TERMINAL

WIRE STRIP LENGTH	INSULATION DIAMETER RANGE
4.00-4.50 mm [1.57-.177 IN]	1.50-1.85 mm [0.059-.073 IN]

TERMINAL APPLICATION SPECIFICATION

TERMINAL	114-13183
114-13183	-

TERMINALS APPLIED

TE TERMINAL	TE TERMINAL	TE TERMINAL	TE TERMINAL
1438616-3	1642772-1	1924968-3	2098165-1
1438616-7	1642948-1	1949674-1	2098753-1
1456574-3	1924275-3	2035124-1	2098762-1
1-1456574-3	1924727-1	2035170-1	2138699-1
1-1456841-3	1-1924727-1	1-2035170-1	1-2138699-1
1456968-3	1924955-3	2035334-3	2312100-3
1-1456968-3	1-1924955-3	2312102-3	2312102-3

WIRE SIZE	CRIMP HEIGHT mm [INCH]	CRIMP HEIGHT REFERENCE SETTING
20 AWG OR 0.50mm2	0.95 +/- 0.05 [0.037 +/- .002]	7.7
22 AWG OR 0.35mm2	0.90 +/- 0.05 [0.035 +/- .002]	8.3

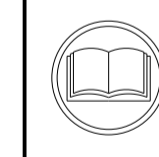

- 1. RECOMMENDED SPARE PARTS
- 2. REFER TO SUPPLIED INSTRUCTION SHEET FOR CLEANING, LUBRICATION & STORAGE OF APPLICATOR.
- 3. APPLY PART NUMBER 1-23419-5 LOCTITE TO THREADS OF ITEM 180. APPLY PART NUMBER 2-23419-6 LOCTITE TO THREADS OF ITEM 242.
- 4. CRIMP HEIGHT REFERENCE SETTING WAS THE SETTING USED WHEN THE APPLICATOR WAS QUALIFIED AT THE FACTORY. ADJUSTMENT MAY BE NECESSARY WHEN RUNNING APPLICATOR IN THE FIELD.
- 5. TE TERMINAL YAZAKI TERMINAL
 1642772-1 7114-4618-02
 1642948-1 7116-4618-02
 1949674-1 7116-5231-08
- 6. THIS APPLICATOR IS EQUIPPED WITH THE DOUBLE ACTING PNEUMATIC FEED WITH SENSORS, AND IS APPLICATION SPECIFIC AND DOES NOT REQUIRE ITEMS 49 & 151.
- 7. USE TERMINAL SUPPORT LOCATION SPECIFIED FOR FEMALE TERMINALS.
- 8. USE TERMINAL SUPPORT LOCATION SPECIFIED FOR MALE TERMINALS.
- 9. TERMINAL LUBRICANT IS RECOMMENDED.

10. UNLESS SPECIFIED OTHERWISE TORQUE VALUES SHALL BE USED PER DOCUMENT, 101-35000.

***WARNING**
 ON INSTALLATION, SET WIRE DISC TO CRIMP HEIGHT REFERENCE SETTING FOR LARGEST WIRE SIZE. CRIMP HEIGHT REFERENCE SETTINGS GREATER THAN THE VALUE SHOWN MAY CAUSE DAMAGE TO THE CRIMP TOOLING. REFER TO THE INSTRUCTION SHEET FOR PROPER SETUP AND ADJUSTMENTS.

ENTRY LEVEL APPLICATOR		ITEM SUBSTITUTION LIST		
PART NUMBER	SAME AS	ITEM	ITEM DESCRIPTION	SUBSTITUTE PART NUMBER
8-2151725-1	2151725-1	1	WIRE CRIMPER	1803669-3
8-2151725-2	2151725-2	3	INSULATION CRIMPER	1-1803627-2
9-2151725-1	2-2151725-1	46	BASIC SUB -ASSEMBLY	1803940-9
9-2151725-2	2-2151725-2	141	BASIC SUB -ASSEMBLY	1-1803940-0
			LUBRICATOR	DELETE

PACIFIC VERSION
 Shown on sheets 3 of 4 & 4 of 4
 (Atlantic version shown on sheets 1 of 4 & 2 of 4)

LOC	DIST	REV	DATE	BY	APPV
A	66				

REV	DATE	DESCRIPTION	DATE	BY	APPV	
-	1	-	-	2844950-1	AIR FEED MODULE	290
-	1	1	1	2119082-8	CAM, SNAIL, INSULATION ADJUSTMENT	244
-	1	1	1	2079764-1	WASHER, WAVE SPRING, CREST-TO-CREST	243
3	-	1	1	2119083-1	RETAINER, INSULATION DIAL	242
-	1	1	1	7-18023-7	SCR, SKT HD CAP M3 X 4.0	241
-	-	-	1	2119580-1	MECHANICAL FEED ASSEMBLY	239
-	-	1	-	2844940-1	AIR FEED MODULE	238
3	-	1	1	1-1752354-6	STANDOFF, HOLD-DOWN	180
-	1	1	1	9931111-1	PIN, SLOTTED SPRING 3.0 X 20.0	177
-	1	1	1	8-22280-7	SPRING, COMPRESSION	176
-	1	1	1	1752353-2	GUIDE PIN, HOLDDOWN	175
-	1	1	1	1901680-2	GUIDE PIN, HOLDDOWN	174
-	REF	REF	REF	994970-2	COUNTER, MAGNETIC	164
6	-	-	1	2119641-2	FEED CAM, AIR FEED	151
-	1	1	1	2168083-8	SCR, SKT HD CAP, RoHS, M4 X 16	144
-	4	4	4	2168083-9	SCR, SKT HD CAP, RoHS, M4 X 20	143
-	-	-	1	2119653-2	FEED CAM, POST FEED	142
-	1	1	1	1-1803583-0	APPLICATOR BASIC ASSEMBLY, SF	141
-	1	1	1	1803516-1	RAM ASSEMBLY, SF PACIFIC	140
9	-	1	1	2119955-1	ASSY, LUBRICATOR, SIDE FEED	113
-	1	1	1	2844908-1	SCREW, LOCKING	99
-	1	1	1	2844907-1	POST, LOCKING	98
-	1	1	1	455888-6	SPACER, CRIMPER	82
-	1	1	1	1803607-3	DOCUMENTATION PACKAGE	71
-	1	1	1	2119791-5	DEPRESSOR, WIRE	70
-	1	1	1	2119943-1	WASHER, SPACER	69
-	1	1	1	2119740-1	TAG, IDENTIFICATION	67
-	2	2	2	2168078-1	SCREW, DRIVE, RH, RoHS, 2 x .188	66
-	1	1	1	5-18022-5	SCR, HEX HD CAP, M4 X 6.0	59
-	1	1	1	1338685-1	PAWL, FEED	56
-	1	1	1	1-5018030-0	NUT, HEX, REG, RoHS, M3.5	52
-	1	1	1	1901681-1	HOLDDOWN, TERMINAL	51
6	-	-	1	18023-9	SCR, SKT HD CAP M4 X 6.0	49
-	-	-	1	2119652-1	FEED CAM, PRE FEED	48
-	1	1	1	1803602-1	SCR, BHSC, RoHS (M8 X 25)	41
-	1	1	1	1752356-1	SUPPORT, TERMINAL	34
-	2	2	2	2079383-5	SCR, BHSC, RoHS (M4 X 20)	33
-	2	2	2	2-2844962-6	SPACER, CYLINDRICAL, STRIP GUIDE	30
-	1	1	1	2844992-4	ASSEMBLY, STRIP GUIDE	29
-	1	1	1	455888-2	SPACER, CRIMPER	28
-	1	1	1	240792-1	DRAG, TERMINAL	25
-	1	1	1	1320928-2	STRIP GUIDE	24
-	1	1	1	2168083-2	SCR, SKT HD CAP, RoHS, M4 X 8.0	21
-	2	2	2	1-18028-2	WASHER, FLAT, REG M4	20
-	1	1	1	2119533-3	STRIPPER, SIDE FEED	19
1	-	1	1	2119806-1	INSERT, SHEAR	13
-	1	1	1	3-22280-3	SPRING, COMPRESSION	12
-	1	1	1	1-356885-3	STOP, SHEAR	11
1	-	1	1	2119805-1	SHEAR HOLDER, FRONT	10
1	-	1	1	1803095-6	FLOATING SHEAR, FRONT	9
1	-	1	1	1803537-7	ANVIL, COMBINATION	8
-	-	-	-	-	-	7
-	-	-	-	-	-	6
-	1	1	1	2119757-1	DEPRESSOR, SHEAR	5
-	1	1	1	238011-4	BLOCK, CRIMPER SPACER	4
1	-	1	1	1-1803019-2	CRIMPER, INSULATION O	3
-	-	-	-	-	-	2
1	-	1	1	1803364-3	CRIMPER, WIRE PREMIUM	1

DIMENSIONS:	TOLERANCES UNLESS OTHERWISE SPECIFIED:	DATE	BY	APPV
mm	0 PLC ± 1 PLC ± 2 PLC ± 3 PLC ± 4 PLC ± ANGLES ±	31 JUL 2012	C. MOYER	T. ELBIN
MATERIAL:		FINISH:		
WEIGHT:		SCALE: 1:2		
CUSTOMER ACCESSIBLE PRODUCTION DRAWING		SHEET 3 OF 4		

STE TE Connectivity
 Harrisburg, PA 17105-3608

NAME: Ocean Side Feed Applicator

SIZE: A1 CAGE CODE: 00779 DRAWING NO: 2151725

RESTRICTED TO: 3

LOC		DIST		REVISIONS			
A	66	P	LTM	DESCRIPTION	DATE	DWN	APVD
		-		SEE SHEET 1			

FEED TYPE MECHANICAL

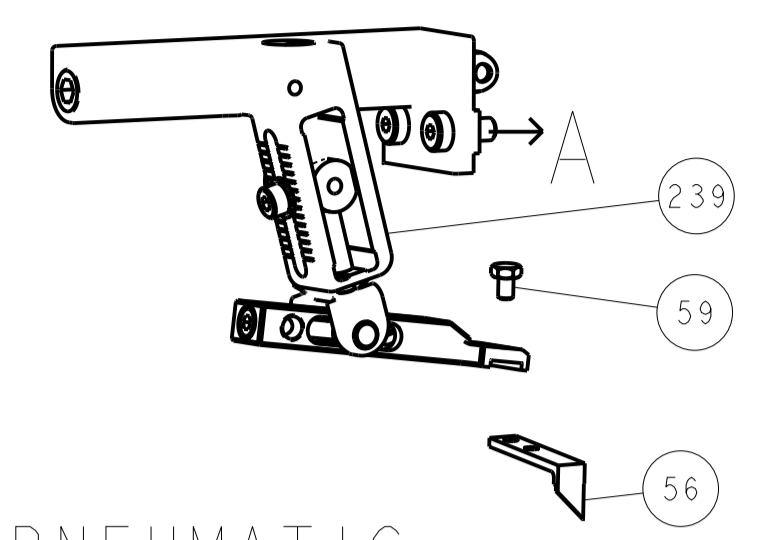

PNEUMATIC

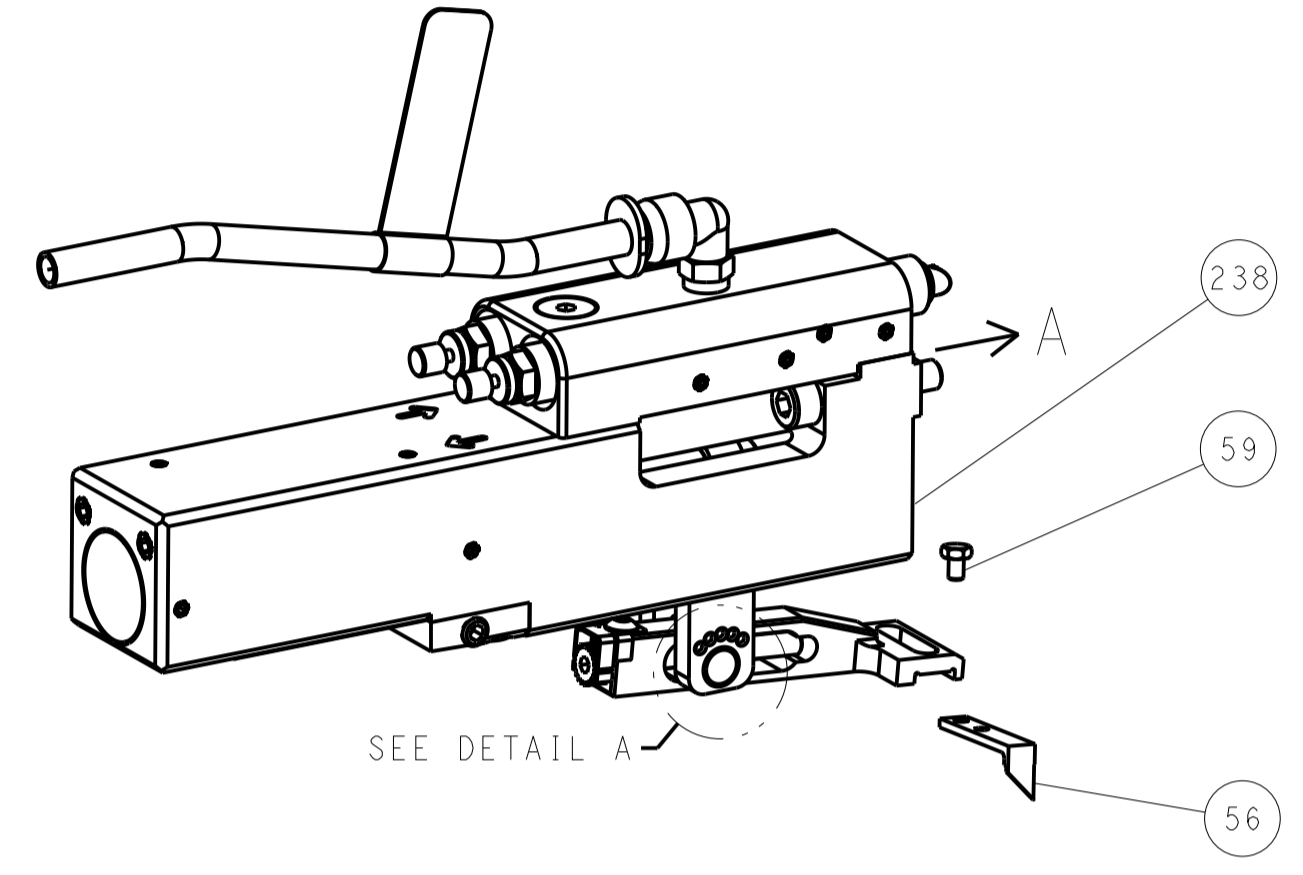

FEED SPRING SETTING POSITION (SHOWN FROM REAR SIDE)

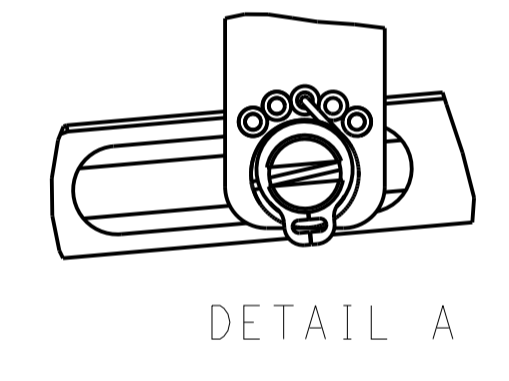

DOUBLE ACTING PNEUMATIC WITH SENSORS

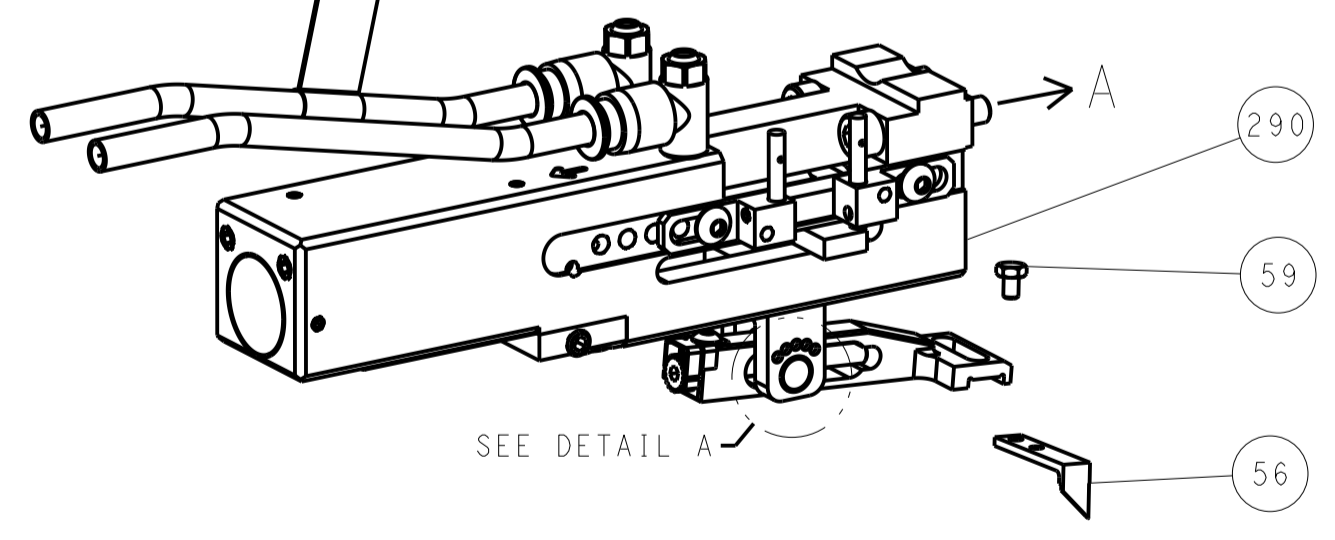

CAM POSITIONS

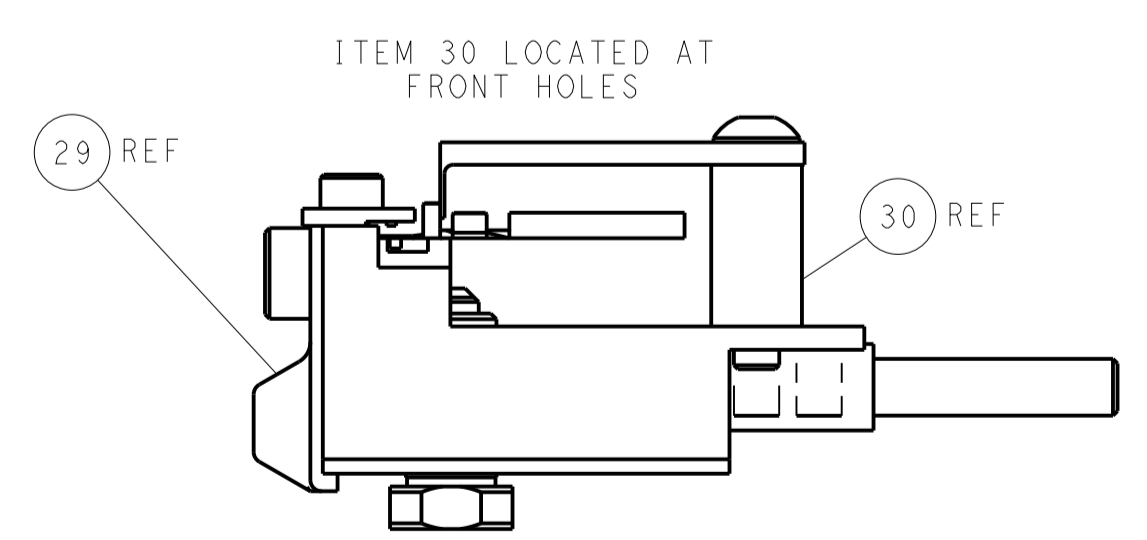
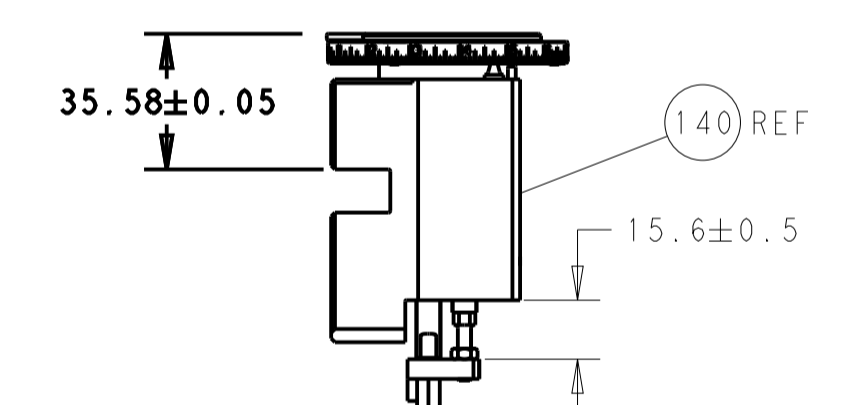
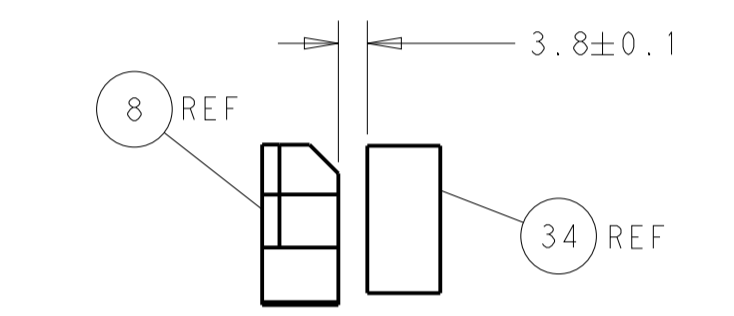
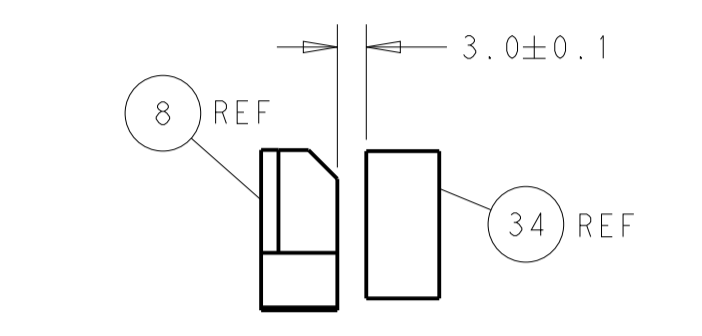
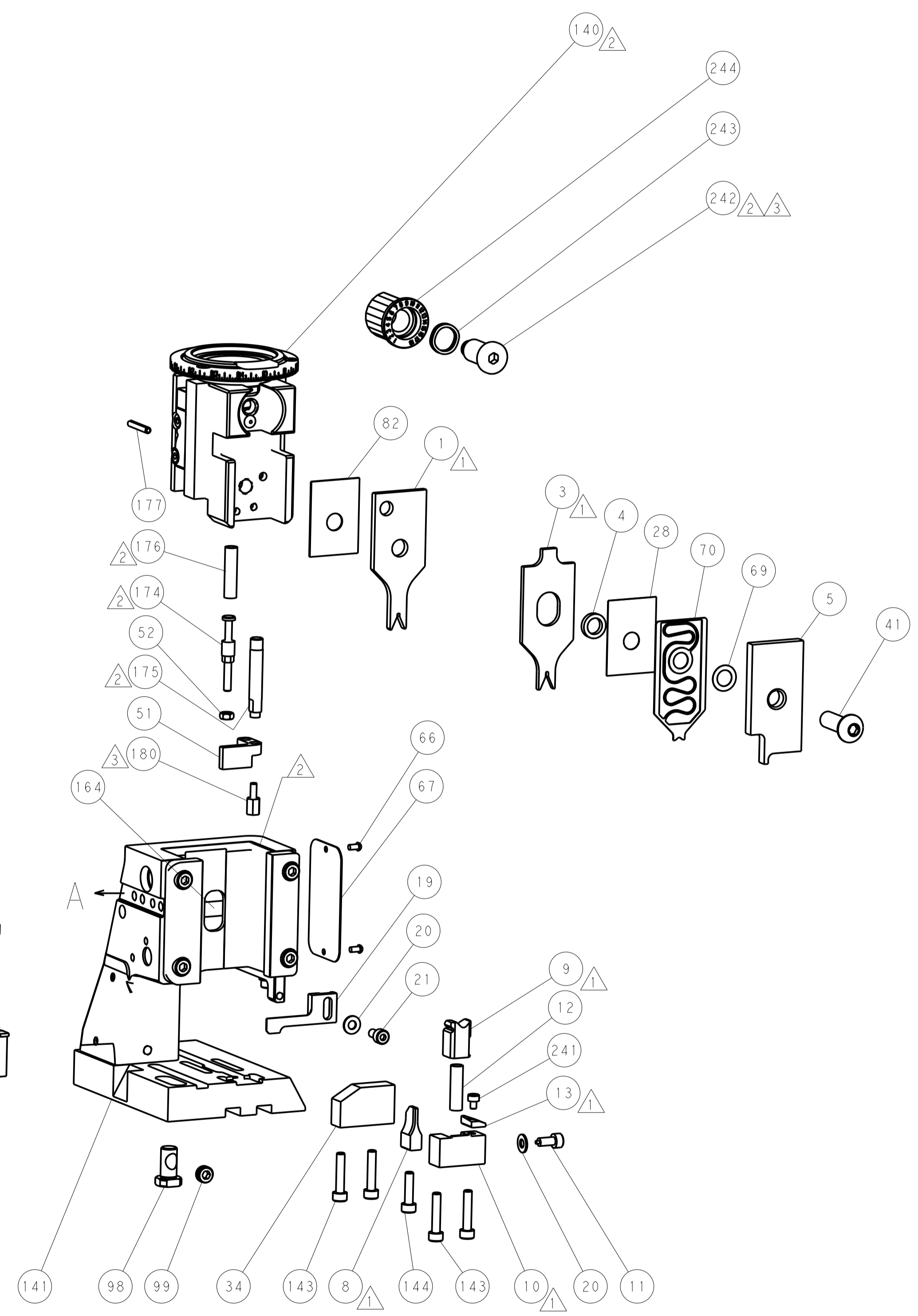
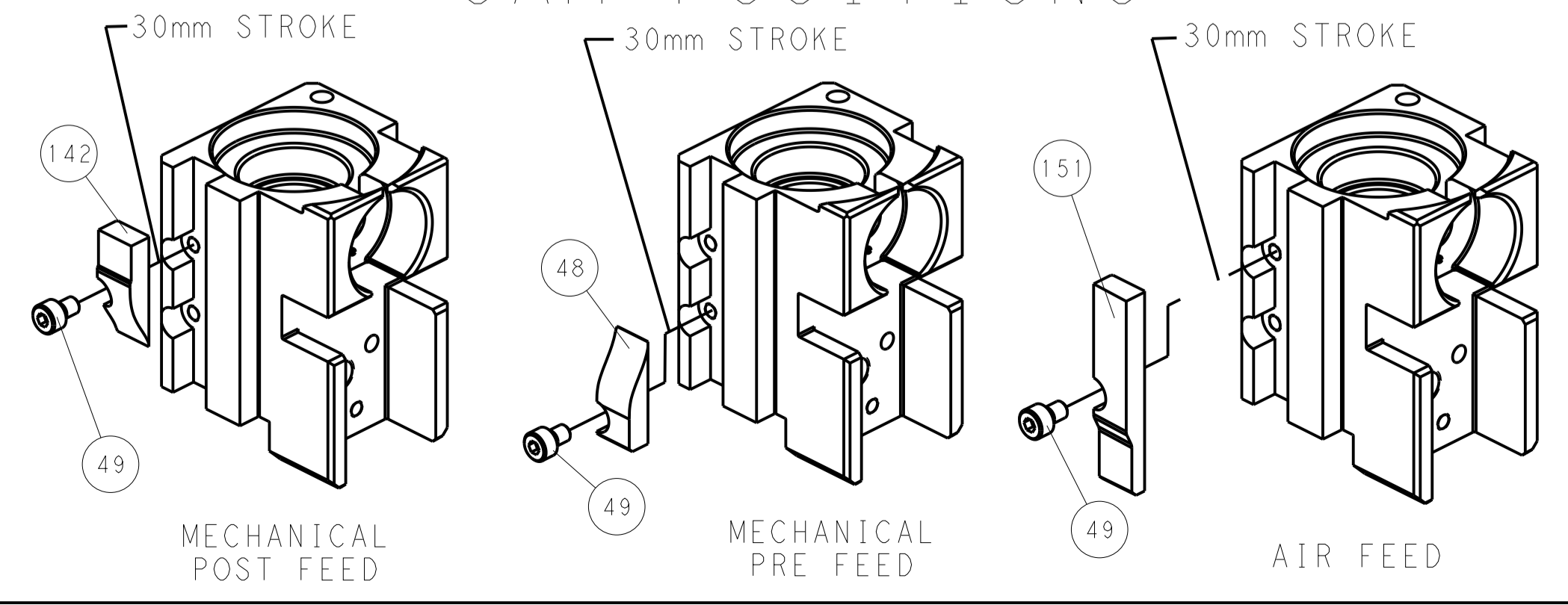

FEED TRACK POSITION GUIDE BY INSULATION BARREL

PACIFIC VERSION
 Shown on sheets 3 of 4 & 4 of 4
 (Atlantic version shown on sheets 1 of 4 & 2 of 4)

DIMENSIONS:		TOLERANCES UNLESS OTHERWISE SPECIFIED:		DWN C. MOYER 31 JUL 2012		TE Connectivity	
mm	0 PLC ±	1 PLC ±	2 PLC ±	3 PLC ±	4 PLC ±	Harrisburg, PA 17105-3608	
MATERIAL:		FINISH:		APVD T. ELBIN 31 JUL 2012		NAME	
				PRODUCT SPEC		Ocean Side Feed Applicator	
				APPLICATION SPEC		SIZE CAGE CODE DRAWING NO	
				WEIGHT		A 00779 C=2151725	
				CUSTOMER ACCESSIBLE PRODUCTION DRAWING		SCALE 1:2 SHEET 4 OF 4 REV U2	