

THIS DRAWING IS UNPUBLISHED. RELEASED FOR PUBLICATION  
 © COPYRIGHT BY TYCO ELECTRONICS CORPORATION. ALL INTERNATIONAL RIGHTS RESERVED.

LOC	DIST	REVISIONS					
		P	LTR	DESCRIPTION	DATE	DWN	APVD
G	14						
		D1		REV PER ECR 10-013673	29JUN10	JR	TM

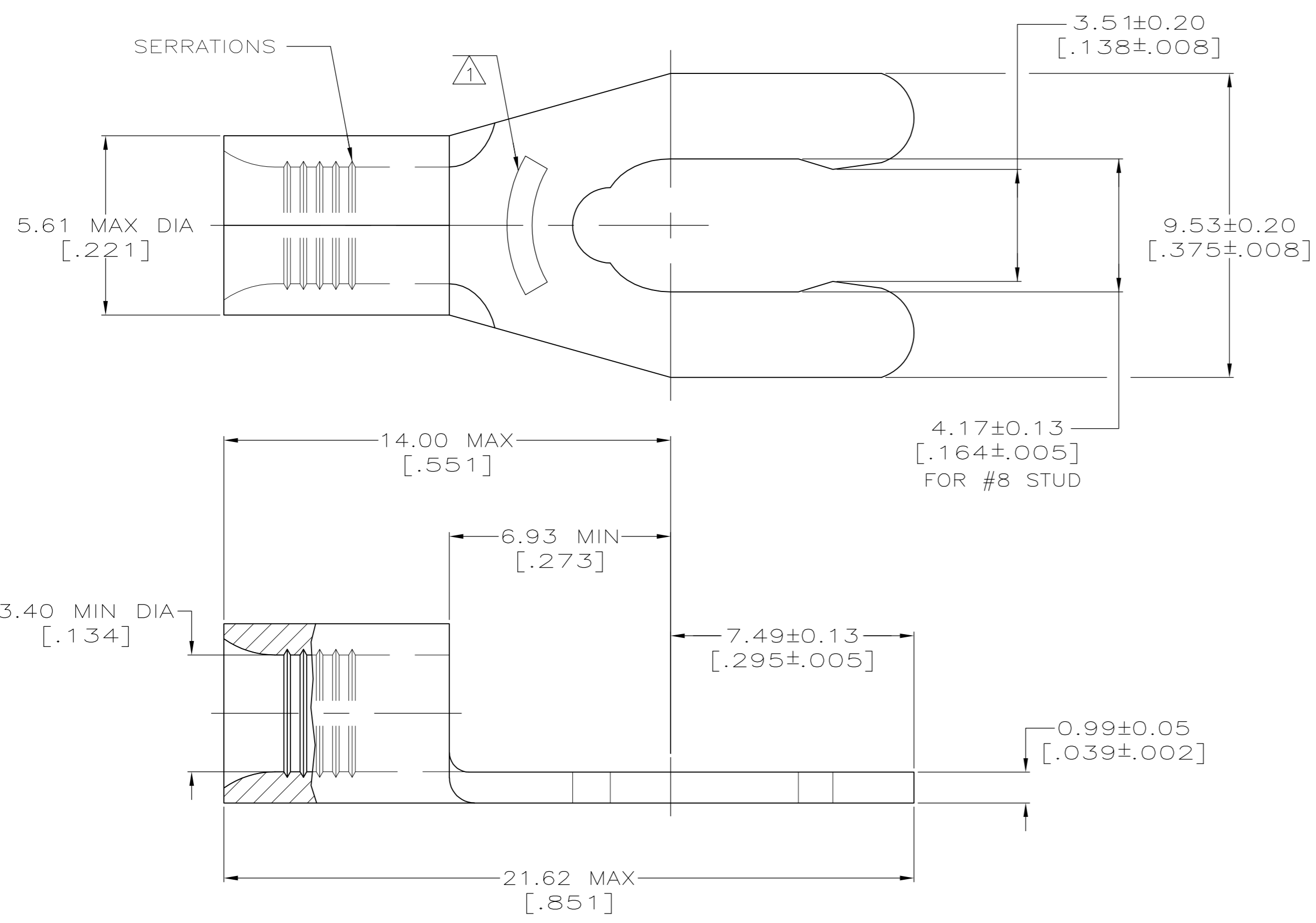

<b>AMP</b> WIRE RANGE	Listed FILE E13288	LR7189 Certified
12-10 AWG STRANDED	12-10 AWG STRANDED	NOT CERTIFIED

- 1 STAMP 8S AMP 12-10\* APPROX AS SHOWN  
8S INDICATES STUD SIZE
- 2 PHOSPHOR BRONZE PER ASTM B-103, ANNEALED
- 3 TIN PLATE 0.00254 [.000100] MIN PER ASTM B545

OBsolete	2500	ON TAPE	52707-3
	--	LOOSE PIECE	52707-1
QTY		PACKAGING TYPE	PART NO.

MAX RECOMMENDED OPERATING TEMPERATURE: 170°C MAX	THIS DRAWING IS A CONTROLLED DOCUMENT.		DWN TA BRINKMAN 2-16-93	Tyco Electronics Corporation Harrisburg, PA 17105-3608
	VOLTAGE RATING: N/A	DIMENSIONS: MM [ INCHES ]	CHK DA PATTERSON 2-16-93	
CIRCULAR MIL AREA: 2.62-6.64mm² [5,180-13,100] STRANDED	TOLERANCES UNLESS OTHERWISE SPECIFIED: 0 PLC ± - 1 PLC ± - 2 PLC ± - 3 PLC ± - 4 PLC ± - ANGLES ± -	MATERIAL -2	APVD JL MECKLEY 2-16-93	PRODUCT SPEC APPLICATION SPEC
		FINISH -3	WEIGHT -	SIZE A2
			CUSTOMER DRAWING	CAGE CODE 00779
				DRAWING NO 52707
				RESTRICTED TO -
				SCALE 8:1
				SHEET 1 of 1
				REV D1