

HDMI COMPLIANCE TEST SOFTWARE PACKAGE

*“Fast, Accurate
HDMI Compliance
Test Solution”*

Leading Features

- **Built for X-Replay™ Automated Software—compatible with all LeCroy High-performance Real-time and Sampling oscilloscopes**
- **Backward compatible with Digital Video Interactive (DVI)**
- **Based on same TDMS Serial Data Link developed by Silicon Image**
- **HDMI supports standard, enhanced, or high-definition video, plus multi-channel digital audio on a single cable**
- **HDMI was designed specifically for consumer electronics applications, it offers an array of additional consumer enhancements**
- **Amplitude, Timing, Jitter and Cable Measurements**
- **Custom Clock recovery supports Filtered Jitter measurements**
- **Supports a variety of cable configurations and test fixture scenarios**

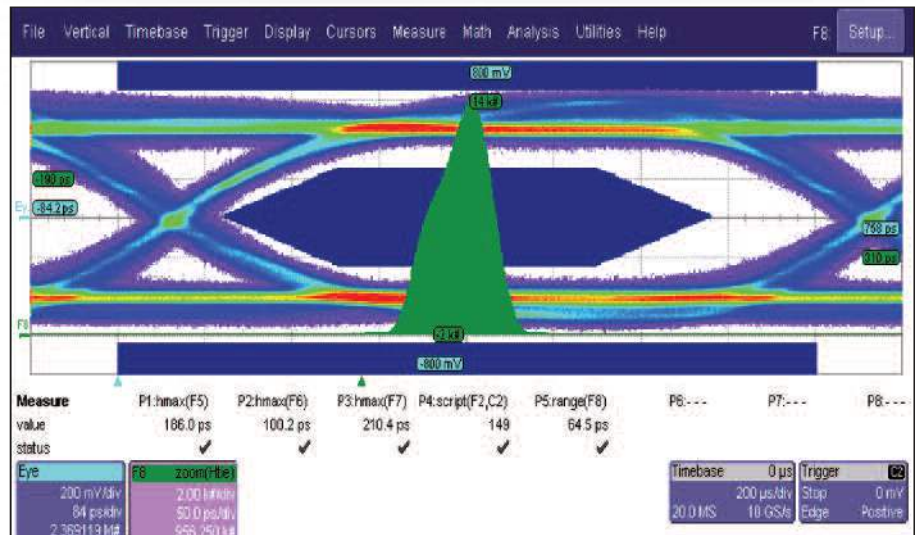

An Innovative Compliance Test Tool

The SDA-HDMI software package for the SDA family of Serial Data Analyzers provides a concise set of validation/verification and debug tools written in accordance with High Definition Multimedia Interface (HDMI) electrical test specifications. Covered HDMI test modes include Source and Cable Tests covering amplitude-timing, and jitter parameters as well as cable impedance tests.

In addition to standard eye pattern and jitter tests for HDMI, the SDA real-time test equipment platform provides a complete set of amplitude and jitter measurements, as defined in the HDMI specification. This combination of measurements makes SDA-HDMI a cost-effective, compelling HDMI solution.

Additionally, the SDA-HDMI software package takes advantage of all the user-acclaimed test and measurement tools available in LeCroy's instruments:

- **D350ST-SP, WaveLink® 4 GHz Bandwidth Probing System**, available in SP (square pins) input or Solder-In (SI) configurations, for a choice between versatility and the highest signal integrity with the lowest probe loading across the entire bandwidth range.
- **Jitter Wizard tool** available in ASDA-J Advanced Serial Data Analysis package ensures proper jitter measurement setup, allowing for correlation with other test instruments such as BERT, Sampling oscilloscopes or time interval analyzers (TIAs).

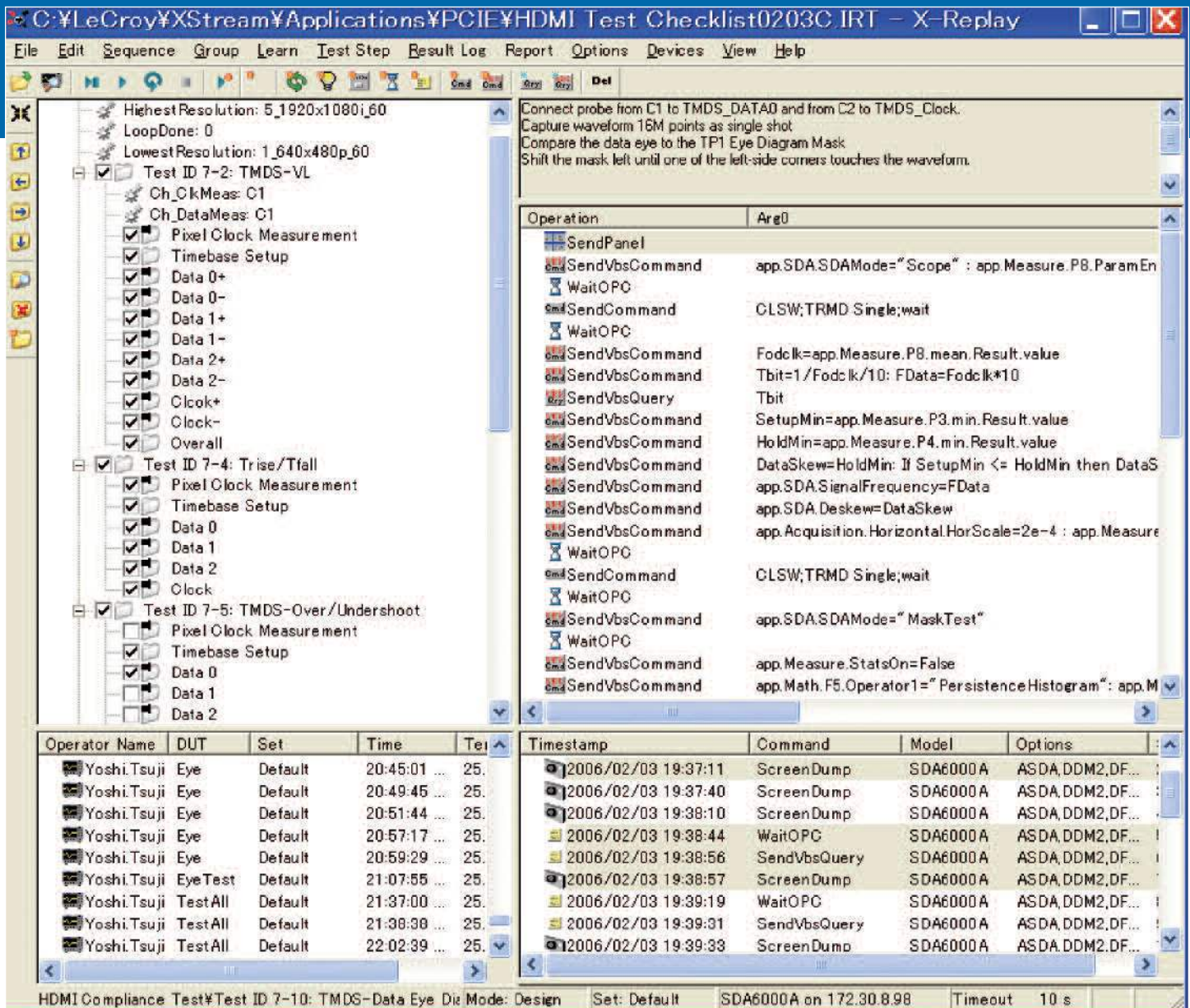

X-Replay Development Environment

X-Replay: A New Generation of Software Tools for HDMI Developers

As hardware designers are quick to recognize, measurement results often need to be summarized and tabulated for quick specification verification. SDA-HDMI goes a leap beyond by incorporating a unique application framework, where every experimental result is saved in XML, format directly compatible with most popular database applications. A report generation

engine interfaces with the underlying Microsoft® Access-compatible database to facilitate custom text and graphics based reports. Sample applications that stand to benefit the most from the new software framework include, but are not limited to:

- **Chipset developers** who require comprehensive silicon characterization to define parametric performance and establish device performance capability.
- **Device development teams** working in parallel development cycles who need to combine, study, and interpret performance data and correlate with prior design runs
- **Manufacturing/Production test environments** where key performance parameters are monitored using control charts or other in-process indicators of device performance

Powerful Debugging Tools Ensure HDMI Connectivity

SDA-HDMI provides access to time-domain-reflectometry (TDR) test capabilities available in LeCroy's line of Near Real Time oscilloscopes (NRO). The use of SDA-HDMI in conjunction with the deep memory and powerful analysis library of the SDA instrument family simplify greatly the verification process.

Clock recovery circuitry and clock extraction via Phase-Locked Loops (PLLs) is another significant design consideration. The flexible clock recovery options in the SDA allow for the simulation of virtually any real receiver PLL configuration, thus allowing the simulation of "what if" scenarios. Jitter results can be measured exactly as the receiver would see them.

Comprehensive and Easy-to-Read Test Reports

As hardware designers are quick to recognize, measurement results often need to be summarized and tabulated for quick specification verification. These test results, together with instrument and signal acquisition/test condition setups, create a fully documented record. SDA-HDMI incorporates a multiple-format report generation engine. This test report contains tabulated numerical values for each individual test result including PASS/FAIL and specification limit columns.



Test Report Generation in X-Replay



Overall result: Pass

DUT: TestAll
 Limits in use: Default
 Scope SN: SDA00683?? Scope Name: UNKNOWN-C1A60A7
 Operator: Yoshi Tsuji
 Computer: YOSHI-NB
 Time of test: 2006/02/03 15:27:55
 Temperature: 18.000000 degrees C

Summary Table

Pass	Test Item	Current Value	Test Criteria
●	Tbit_Lowest_Frequency	3.97222997013286E-09	>0
●	Clock+_TMDS-VL	2.82764106915571	2.7 < n < 2.9
●	Data0-_TMDS-VL	2.82764106915571	2.7 < n < 2.9
●	Data1+_TMDS-VL	2.82764106915571	2.7 < n < 2.9
●	Data1-_TMDS-VL	2.82764106915571	2.7 < n < 2.9
●	Data2+_TMDS-VL	2.82764106915571	2.7 < n < 2.9
●	Data2-_TMDS-VL	2.82764106915571	2.7 < n < 2.9
●	Clock+_TMDS-VL	2.82764106915571	2.7 < n < 2.9
●	Clock-_TMDS-VL	2.83206052892094	2.7 < n < 2.9
●	TMDS-VLmax	2.83206052892094	2.7 < n < 2.9
●	Tbit_Highest_Frequency	6.73402243634817E-10	>0
●	Data0_Trise_Min	1.75975815951824E-10	>7.50E-11
●	Data0_Trise_Max	0.261323477334975	<0.4
●	Data0_Tfall_Min	1.89776011943817E-10	>7.50E-11

HDMI Test Report (Partial)

Specifications and Ordering Information

Advanced Real-time Jitter and Eye Pattern Analysis

While the SDA instrument family includes the ability to measure jitter and eye patterns in real time, the SDA-HDMI package leverages the Advanced Serial Data Analysis Library (ASDA-J), which provides ultimate control of PLL design, jitter measurement conditions that include detailed Data Dependent Jitter (DDj) breakdown and also bit error rate (BER) analysis. The SDA provides pinpoint accuracy for eye mask violations locator, even in the presence of Spread Spectrum Clock (SSC).

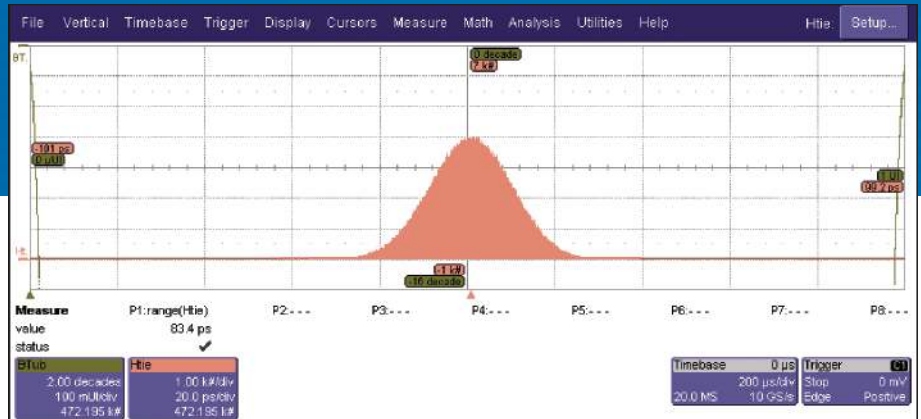

ASDA-J Jitter Analysis

Fixtures Used:

- TPA-P-D – Differential Test Fixture
- TPA-P-SE – Single Ended Test Fixture

Source Device (SDA Series)

Test #	Description
Test 7-2	TMDS-VL
Test 7-4	TDMS-TRISE, TFALL
Test 7-5	TMDS-Over/Undershoot
Test 7-6	TMDS-Inter-Pair Skew
Test 7-7	TDMS-Intra-Pair Skew
Test 7-8	TMDS-Clock Duty Cycle
Test 7-9	TMDS-Clock Jitter
Test 7-10	TMDS-Data Eye Diagram

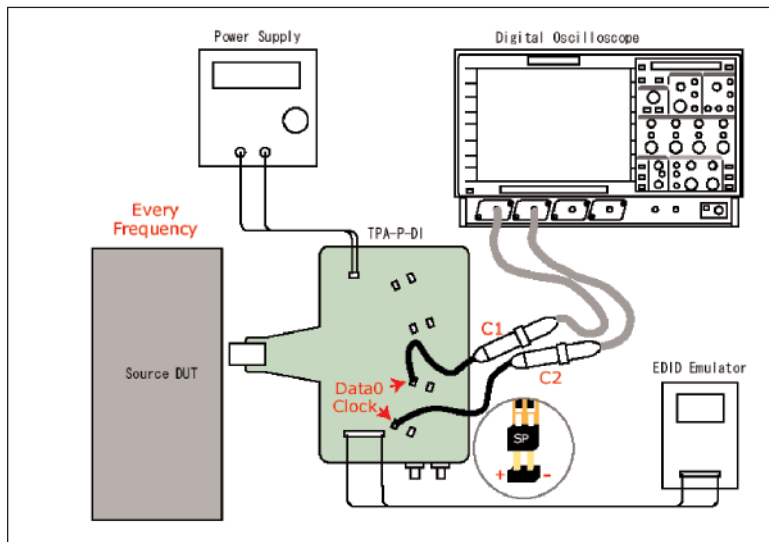

Typical HDMI Test Configuration

Ordering Information

SDA-HDMI software package includes all the software required to run HDMI compliance tests on the SDA/WaveMaster 4 GHz and higher bandwidth real-time oscilloscope family.

Product Configuration

HDMI Compliance Test Software Package for 4 GHz or higher SDA/WaveMaster Family of Digital Storage Oscilloscopes.

Product Code

SDA-HDMI

Recommended System Configuration for HDMI Compliance Tests:

HDMI Solution System Configuration

4 Ch; 4 GHz Serial Data Analyzer; 10 GS/s; 8 Mpts/Ch; 20 GS/s, 16 Mpts/Ch for 2 or 1 Ch	SDA 4000A
Wavelink 4 GHz, 5 V Differential Probe with Small Tip Module	D350ST*
Extra Square Pin Lead for the D350ST	D350ST-SP
HDMI Compliance Test Software Package for 4 GHz or higher SDA/WaveMaster Family of Digital Storage Oscilloscopes	SDA-HDMI
HDMI Test Fixture Kit contains TPA-P-DI Differential Test Fixture and TPA-P-SE Single Ended Test Fixture	TF-HDMI

*For a complete probe, order a WL300 Probe Body with the Probe Tip Module.



1-800-5-LeCroy
www.lecroy.com

Local sales offices are located throughout the world.
To find the most convenient one visit www.lecroy.com