



Part Number: D3C2640Q

Electrical Specifications

Frequency Range (GHz):	26.5	-	40.0
Isolation (dB):	14	MIN	
Insertion Loss (dB):	1.0	MAX	
VSWR:	1.5:1	MIN	
Forward Power (W):	5	AVG	
	30	PK	

Mechanical/Environmental Specifications

Connector Type:	2.4mm
Connector Body:	Passivated stainless steel
Connector Pin:	Gold plated copper
Load Body:	Brass
Magnetic Shunt:	Nickel plated CRS
Operational Temp:	-20°C to +65°C
Weight (oz)	0.9 MAX

D3C2640Q

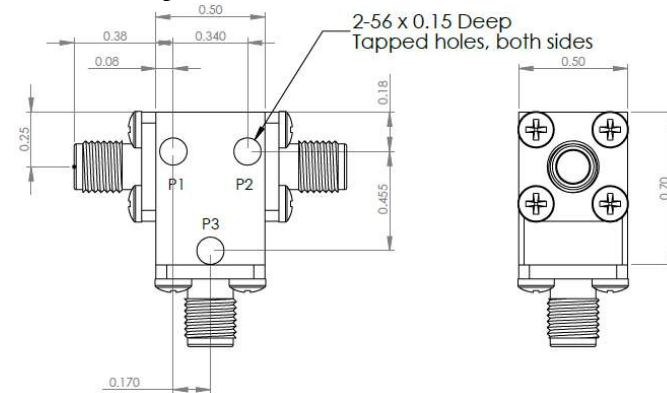

D3C2640Q-3

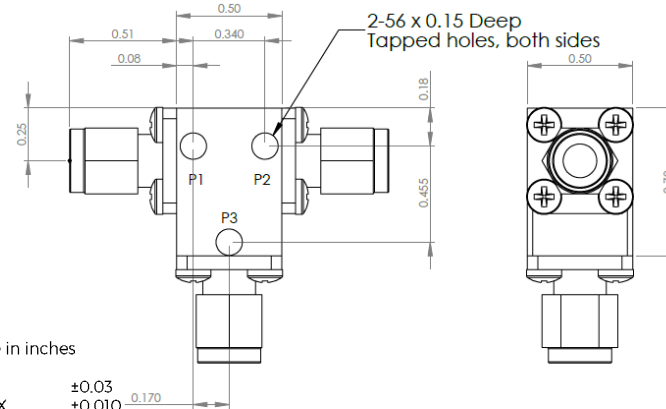

Dimensions are in inches
Tolerance

XX ±0.03
XXX ±0.010

Type of Device	PN Suffix	Connector Configuration Input / Output	PN Example
Single Junction Circulator 3-Port Device Port 1 / Port 2 / Port 3	No Dash	Female / Female / Female	D3C2640Q
	-1	Male / Female / Female	D3C2640Q-1
	-2	Female / Male / Female	D3C2640Q-2
	-3	Male / Male / Male	D3C2640Q-3
	-4	Female / Female / Male	D3C2640Q-4
	-5	Male / Female / Male	D3C2640Q-5
	-6	Male / Male / Female	D3C2640Q-6
	-7	Female / Male / Male	D3C2640Q-7



MEASURED DATA

Part Number: D3C2640Q, P1→P2, P3 Terminated with 50Ω, +25°C

