



MACRONIX  
INTERNATIONAL Co., LTD.

MX30LF1G28AD  
MX30LF2G28AD  
MX30LF4G28AD

---

***3V, 1G/2G/4G-bit NAND Flash Memory***

**MX30LFxG28AD**

# Contents

<b>1. FEATURES</b> .....	<b>6</b>
<b>2. GENERAL DESCRIPTIONS</b> .....	<b>7</b>
Figure 1. Logic Diagram.....	7
<b>2-1. ORDERING INFORMATION</b> .....	<b>8</b>
<b>3. PIN CONFIGURATIONS</b> .....	<b>9</b>
<b>3-1. PIN DESCRIPTIONS</b> .....	<b>11</b>
<b>4. BLOCK DIAGRAM</b> .....	<b>13</b>
<b>5. SCHEMATIC CELL LAYOUT AND ADDRESS ASSIGNMENT</b> .....	<b>14</b>
Table 1-1. Address Allocation (For 1G).....	14
Table 1-2. Address Allocation (For 2G).....	14
Table 1-3. Address Allocation (For 4G).....	14
<b>6. DEVICE OPERATIONS</b> .....	<b>15</b>
<b>6-1. Address Input/Command Input/Data Input</b> .....	<b>15</b>
Figure 2. AC Waveforms for Command / Address / Data Latch Timing.....	15
Figure 3. AC Waveforms for Address Input Cycle.....	15
Figure 4. AC Waveforms for Command Input Cycle.....	16
Figure 5. AC Waveforms for Data Input Cycle.....	16
<b>6-2. Page Read</b> .....	<b>17</b>
Figure 6. AC Waveforms for Read Cycle.....	17
Figure 7. AC Waveforms for Read Operation (Intercepted by CE#).....	18
Figure 8. AC Waveforms for Read Operation (with CE# Don't Care).....	19
Figure 9-1. AC Waveforms for Sequential Data Out Cycle (After Read).....	19
Figure 9-2. AC Waveforms for Sequential Data Out Cycle (After Read) - EDO Mode.....	20
Figure 10. AC Waveforms for Random Data Output.....	21
<b>6-3. Cache Read Sequential</b> .....	<b>22</b>
Figure 11-1. AC Waveforms for Cache Read Sequential.....	23
<b>6-4. Cache Read Random</b> .....	<b>24</b>
Figure 11-2. AC Waveforms for Cache Read Random.....	25
<b>6-5. Page Program</b> .....	<b>26</b>
Figure 12. AC Waveforms for Program Operation after Command 80H.....	26
Figure 13. AC Waveforms for Random Data In (For Page Program).....	27
Figure 14. AC Waveforms for Program Operation with CE# Don't Care.....	28
<b>6-6. Cache Program</b> .....	<b>29</b>
Figure 15-1. AC Waveforms for Cache Program.....	30
Figure 15-2. AC Waveforms for Sequence of Cache Program.....	31



<b>6-7. Block Erase</b> .....	<b>32</b>
Figure 16. AC Waveforms for Erase Operation.....	32
<b>6-8. ID Read</b> .....	<b>33</b>
Table 2. ID Codes Read Out by ID Read Command 90H.....	33
Table 3. The Definition of Byte2-Byte4 of ID Table.....	34
Figure 17-1. AC Waveforms for ID Read Operation.....	35
Figure 17-2. AC Waveforms for ID Read (ONFI Identifier) Operation.....	35
<b>6-9. Status Read</b> .....	<b>36</b>
Table 4. Status Output.....	36
Figure 18. Bit Assignment (HEX Data).....	37
Figure 19. AC Waveforms for Status Read Operation .....	37
<b>6-10. Status Enhance Read (For 2Gb/4Gb)</b> .....	<b>38</b>
<b>6-11. Block Protection Status Read</b> .....	<b>38</b>
Figure 20. AC Waveforms for Status Enhance Operation.....	38
Table 5. Block-Protection Status Output .....	39
Table 6-1. Address Cycle Definition of Block (1G) .....	39
Table 6-2. Address Cycle Definition of Block (2G) .....	39
Table 6-3. Address Cycle Definition of Block (4G) .....	39
Figure 21. AC Waveforms for Block Protection Status Read .....	40
<b>6-12. Reset</b> .....	<b>41</b>
Figure 22. AC waveforms for Reset Operation .....	41
<b>6-13. Parameter Page Read (ONFI)</b> .....	<b>42</b>
Figure 23. AC waveforms for Parameter Page Read (ONFI) Operation .....	42
Figure 24. AC Waveforms for Parameter Page Read (ONFI) Random Operation (For 05h-E0h) .....	43
Table 7-1. Parameter Page (ONFI) - For 1Gb.....	44
Table 7-2. Parameter Page (ONFI) - For 2Gb.....	46
Table 7-3. Parameter Page (ONFI) - For 4Gb.....	48
<b>6-14. Unique ID Read (ONFI) with PUF-like Code Structure</b> <sup>Note</sup> .....	<b>50</b>
Figure 25. AC waveforms for Unique ID Read Operation .....	50
Figure 26. AC waveforms for Unique ID Read Operation (For 05h-E0h).....	51
<b>6-15. Feature Set Operation (ONFI)</b> .....	<b>52</b>
Table 8-1. Definition of Feature Address.....	52
Table 8-2. Sub-Feature Parameter Table of Feature Address - 01h (Timing Mode) .....	52
Table 8-3. Sub-Feature Parameter Table of Feature Address - 80h (Programmable I/O Drive Strength).....	52
Table 8-4. Sub-Feature Parameter Table of Feature Address - 89h (Special Read for Data Recovery Operation).....	53
Table 8-5. Sub-Feature Parameter Table of Feature Address - 90h (Array Operation Mode).....	53
Table 8-6. Sub-Feature Parameter Table of Feature Address - A0h (Block Protection Operation) (note 1).....	54
Table 8-7. Sub-Feature Parameter Table of Feature Address – B0h (Configuration).....	54

Figure 27. The Flowchart of I/O Drive Strength Bits Program Operation .....	55
<b>6-15-1. Set Feature (ONFI) .....</b>	<b>56</b>
Figure 28-1. AC Waveforms for Set Feature (ONFI) Operation .....	56
<b>6-15-2. Get Feature (ONFI).....</b>	<b>57</b>
Figure 28-2. AC Waveforms for Get Feature (ONFI) Operation.....	57
<b>6-15-3. Special Read for Data Recovery.....</b>	<b>58</b>
Figure 29. Procedure of entering /exiting the Special Read for Data Recovery operation.....	58
<b>6-15-4. Secure OTP (One-Time-Programmable) Feature .....</b>	<b>59</b>
Figure 30. AC Waveforms for OTP Data Read .....	59
Figure 31. AC Waveforms for OTP Data Read with Random Data Output.....	60
Figure 32-1. AC Waveforms for OTP Data Program (1Gb).....	61
Figure 32-2. AC Waveforms for OTP Data Program (2Gb/4Gb).....	62
Figure 33. AC Waveforms for OTP Data Program with Random Data Input.....	63
Figure 34. AC Waveforms for OTP Protection Operation .....	64
<b>6-15-5. Block Protection .....</b>	<b>65</b>
Table 9. Definition of Protection Bits .....	65
Figure 35. PT Pin and Block Protection Mode Operation .....	66
<b>6-15-6. Randomizer Operation .....</b>	<b>67</b>
Table 10. The definition of RANDOPT bit for the randomized area per page (as grey color) .....	67
Figure 36. Flowchart of RANDEN and RANDOPT Bits Program Operation .....	68
<b>6-16. Two-Plane Operations (For 2Gb/4Gb) .....</b>	<b>69</b>
<b>6-17. Two-Plane Program (ONFI &amp; Traditional) &amp; Two-Plane Cache Program (ONFI &amp; Traditional) ....</b>	<b>69</b>
<b>6-18. Two-plane Block Erase (ONFI &amp; Traditional) .....</b>	<b>69</b>
Figure 37-1. AC Waveforms for Two-plane Program (ONFI) .....	70
Figure 37-2. AC Waveforms for Page Program Random Data Two-plane (ONFI).....	71
Figure 38. AC Waveforms for Two-plane Cache Program (ONFI).....	72
Figure 39. AC Waveforms for Two-plane Erase (ONFI).....	73
Figure 40. AC waveforms for Two-plane Program (Traditional).....	73
Figure 41. AC waveforms for Two-plane Cache Program (Traditional).....	73
Figure 42. AC waveforms for Two-plane Erase (Traditional).....	74
<b>7. PARAMETERS.....</b>	<b>75</b>
<b>7-1. ABSOLUTE MAXIMUM RATINGS .....</b>	<b>75</b>
Figure 43. Maximum Negative Overshoot Waveform .....	75
Figure 44. Maximum Positive Overshoot Waveform .....	75
<b>7-2. LATCH-UP CHARACTERISTICS .....</b>	<b>75</b>
Table 11. Operating Range .....	76
Table 12. DC Characteristics.....	76
Table 13. Capacitance.....	77
Table 14. AC Testing Conditions .....	77
Table 15. Program and Erase Characteristics.....	77
Table 16. AC Characteristics .....	78



<b>8. OPERATION MODES: LOGIC AND COMMAND TABLES</b> .....	<b>79</b>
Table 17. Logic Table .....	79
Table 18-1. HEX Command Table.....	80
Table 18-2. Two-plane Command Set (For 2Gb/4Gb) .....	80
<b>8-1. R/B#: Termination for The Ready/Busy# Pin (R/B#)</b> .....	<b>81</b>
Figure 45. R/B# Pin Timing Information .....	82
<b>8-2. Power On/Off Sequence</b> .....	<b>83</b>
Figure 46. Power On/Off Sequence .....	83
<b>8-2-1. WP# Signal</b> .....	<b>84</b>
Figure 47-1. Enable Programming of WP# Signal .....	84
Figure 47-2. Disable Programming of WP# Signal .....	84
Figure 47-3. Enable Erasing of WP# Signal.....	84
Figure 47-4. Disable Erasing of WP# Signal .....	84
<b>9. SOFTWARE ALGORITHM</b> .....	<b>85</b>
<b>9-1. Invalid Blocks (Bad Blocks)</b> .....	<b>85</b>
Figure 48. Bad Blocks.....	85
Table 19. Valid Blocks .....	85
<b>9-2. Bad Block Test Flow</b> .....	<b>86</b>
Figure 49. Bad Block Test Flow.....	86
<b>9-3. Failure Phenomena for Read/Program/Erase Operations</b> .....	<b>86</b>
Table 20. Failure Modes.....	86
<b>9-4. Program</b> .....	<b>87</b>
Figure 50. Failure Modes .....	87
Figure 51. Program Flow Chart.....	87
<b>9-5. Erase</b> .....	<b>87</b>
Figure 52. Erase Flow Chart .....	88
Figure 53. Read Flow Chart.....	88
<b>10. PACKAGE INFORMATION</b> .....	<b>89</b>
<b>10-1. 48-TSOP(I) (12mm x 20mm)</b> .....	<b>89</b>
<b>10-2. 63-ball 9mmx11mm VFBGA</b> .....	<b>90</b>
<b>11. REVISION HISTORY</b> .....	<b>91</b>

## 3V, 1Gb/2Gb/4Gb NAND Flash Memory

### 1. FEATURES

- 1G/2G/4G-bit SLC NAND Flash
  - Bus: x8
  - Page size:
    - (2048+128) byte for 1Gb/2Gb
    - (4096+256) byte for 4Gb
  - Block size:
    - (128K+8K) byte for 1Gb/2Gb
    - (256K+16K) byte for 4Gb ,
  - Plane size:
    - 1024-block/plane x1 for 1Gb
    - 1024-block/plane x 2 for 2Gb/4Gb
- **ONFI 1.0 compliant**
- **Multiplexed Command/Address/Data**
- **User Redundancy**
  - 128-byte attached to each page for 1Gb/2Gb
  - 256-byte attached to each page for 4Gb
- **Fast Read Access**
  - Latency of array to register: 25us
  - Sequential read: 20ns
- **Cache Read Support**
- **Page Program Operation**
  - Page program time: 320us( typ.)
- **Cache Program Support**
- **Block Erase Operation**
  - Block erase time: 4ms (typ.)
- **Single Voltage Operation:**
  - VCC: 2.7 - 3.6V
- **Low Power Dissipation**
  - Max. 30mA
  - Active current (Read/Program/Erase)
- **Standby Mode**
  - 50uA (Max) standby current
- **Hardware Data Protection:** WP# pin
- Block#0-7 are valid with ECC at shipping
- **Block Protection**
  - PT (Protection) pin: active high at power-on, which protects the entire chip. The pin has an internal weak pull down.
  - Temporary protection/un-protection function (enabling by PT pin)
  - Solid protection (enabling by PT pin)
- **Device Status Indicators**
  - Ready/Busy (R/B#) pin
  - Status Register
- **Chip Enable Don't Care**
  - Simplify System Interface
- **Unique ID Read (ONFI) with PUF-like code structure**
- **Secure OTP support**
- **High Reliability**
  - Randomizer (Default disabled): Enabled by Set Feature
  - Special Read for Data Recovery: Enabled by Set Feature
  - Endurance: typical 60K cycles (with 8-bit ECC per (512+32) Byte)
  - Data Retention: 10 years<sup>Note</sup>
- **Wide Temperature Operating Range**
  - 40°C to +85°C
- **Package:**
  - 1) 48-TSOP(I) (12mm x 20mm)
  - 2) 63-ball 9mmx11mm VFBGAAll packaged devices are RoHS Compliant and Halogen-free.

**Note:** Please contact Macronix for Reliability report on the detailed condition of retention test.

## 2. GENERAL DESCRIPTIONS

The MX30LFxG28AD is a 1Gb/2Gb/4Gb SLC NAND Flash memory device. Its standard NAND Flash features and reliable quality of typical P/E cycles 60K (with host ECC), which makes it most suitable for embedded system code and data storage.

The product family requires 8-bit ECC per (512+32)B.

The MX30LFxG28AD is typically accessed in pages of 2,176-byte (for 1Gb/2Gb) and 4,352-byte (for 4Gb) bytes for read and program operations.

The MX30LFxG28AD array is organized as thousands of blocks, which is composed by 64 pages of (2,048+128) byte for 1Gb/2Gb or 64 pages of (4,096+256) byte for 4Gb. Each page has an additional 128-byte (for 1Gb/2Gb) or 256-byte (for 4Gb) for ECC and other purposes. The device has an on-chip buffer of 2,176-byte (for 1Gb/2Gb) and 4,352-byte (for 4Gb) for data load and access.

The Cache Read Operation of the MX30LFxG28AD enables first-byte read-access latency of 25us and sequential read of 20ns and the latency time of next sequential page will be shorten from tR to tRCBSY.

The MX30LFxG28AD power consumption is 30mA during all modes of operations (Read/Program/Erase), 50uA in standby mode.

**Figure 1. Logic Diagram**

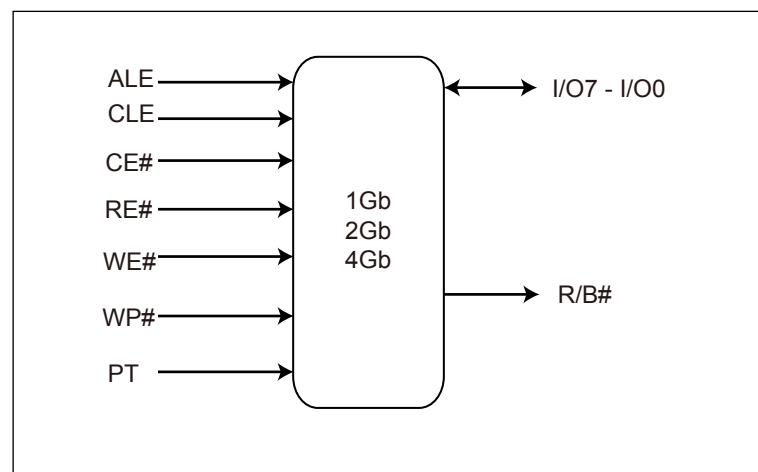

## 2-1. ORDERING INFORMATION

### Part Name Description

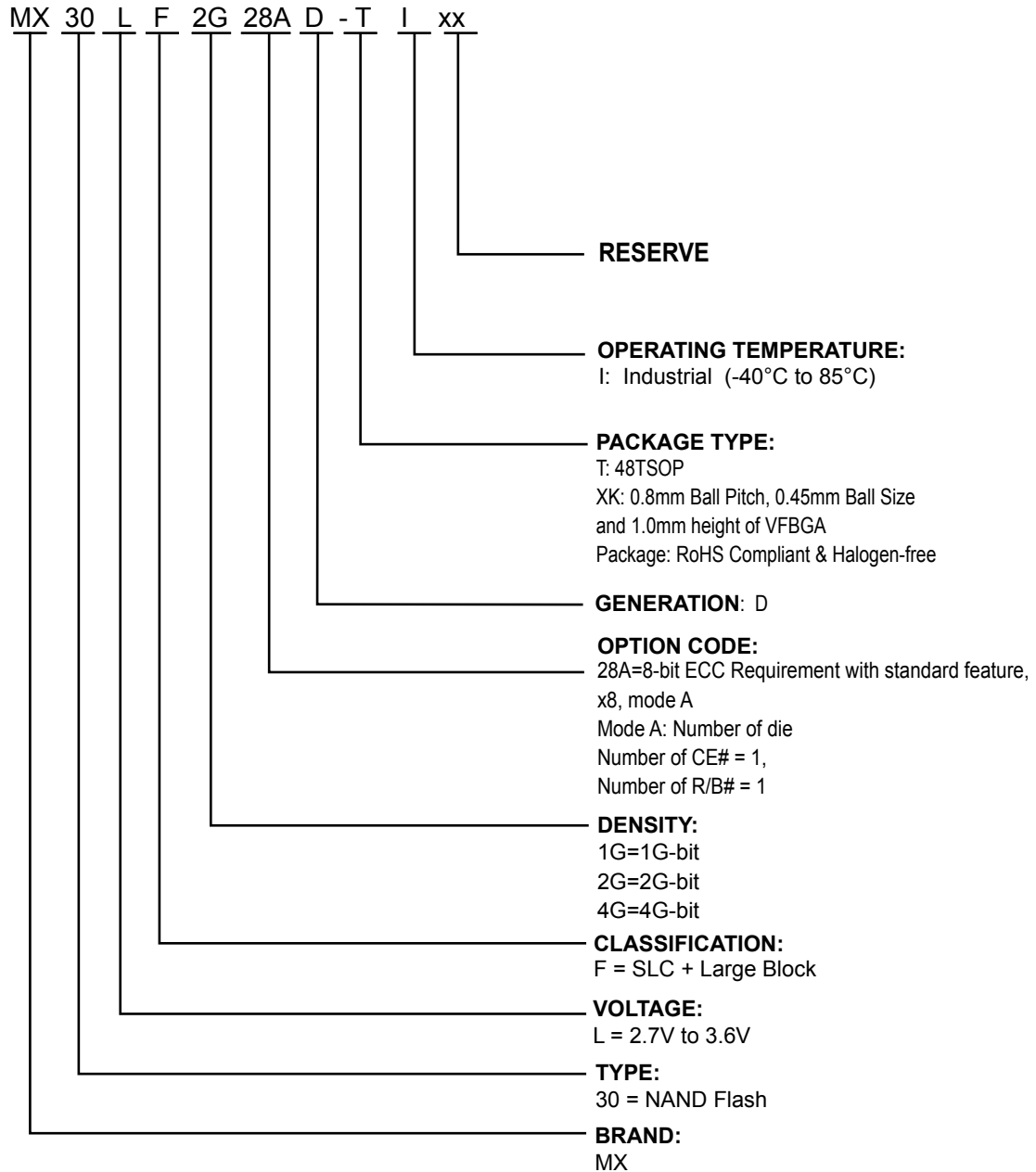

Please contact Macronix regional sales for the latest product selection and available form factors.

Part Number	Density	Organization	VCC Range	Package	Temperature Grade
MX30LF1G28AD-TI	1Gb	x8	3V	48-TSOP	Industrial
MX30LF1G28AD-XKI	1Gb	x8	3V	63-VFBGA	Industrial
MX30LF2G28AD-TI	2Gb	x8	3V	48-TSOP	Industrial
MX30LF2G28AD-XKI	2Gb	x8	3V	63-VFBGA	Industrial
MX30LF4G28AD-TI	4Gb	x8	3V	48-TSOP	Industrial
MX30LF4G28AD-XKI	4Gb	x8	3V	63-VFBGA	Industrial



### 3. PIN CONFIGURATIONS

#### 48-TSOP

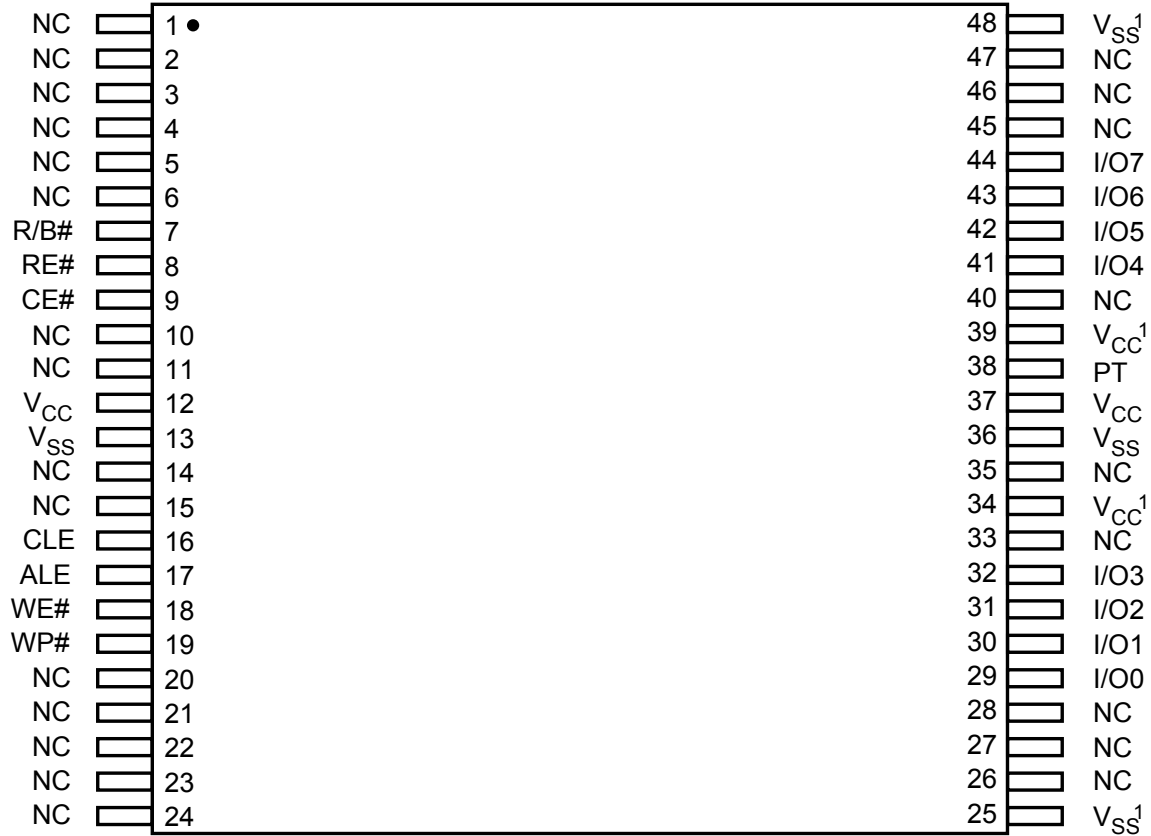

**Note 1.** These pins might not be connected internally. However, it is recommended to connect these pins to power(or ground) as designated for ONFI compatibility.

### 63-ball 9mmx11mm VFBGA

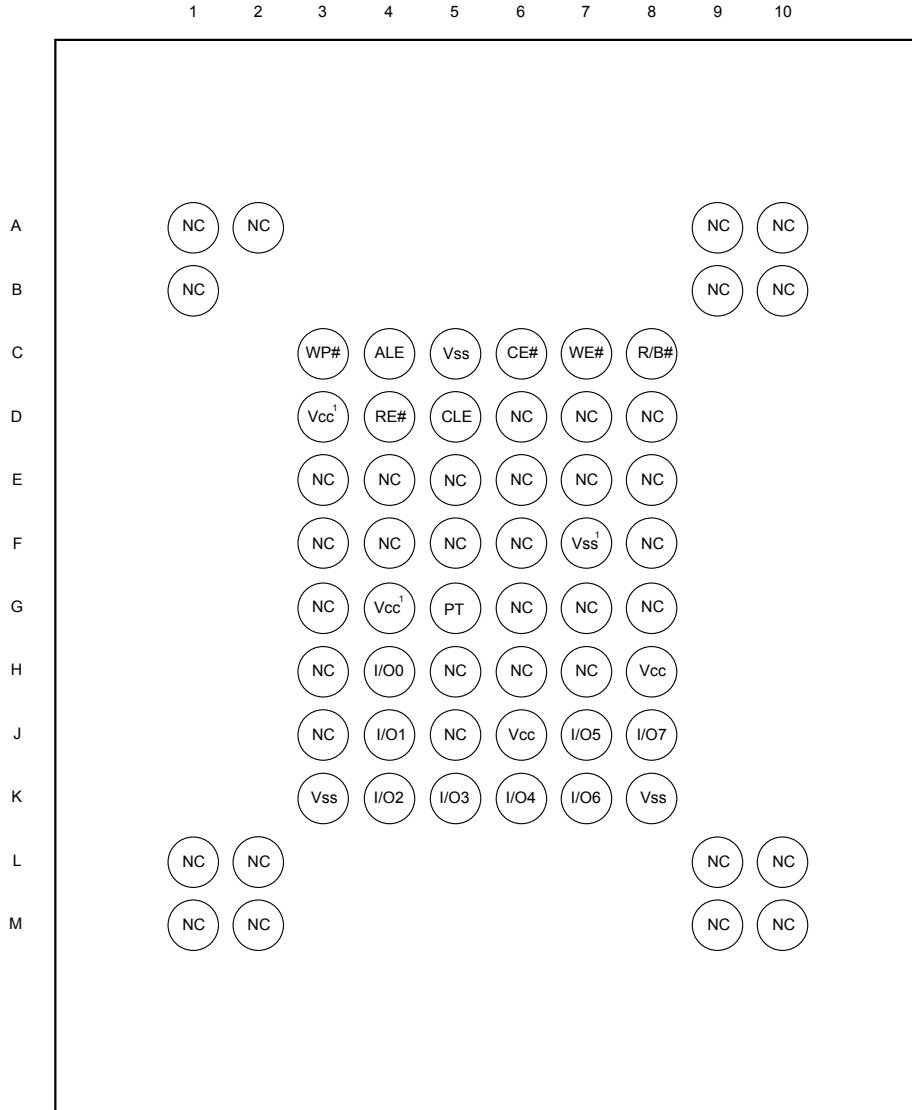

**Note 1.** These pins might not be connected internally; however, it is recommended to connect these pins to power (or ground) as designated for ONFI compatibility.

### 3-1. PIN DESCRIPTIONS

<b>SYMBOL</b>	<b>PIN NAME</b>
<b>I/O7 - I/O0</b>	Data I/O port
<b>CE#</b>	Chip Enable (Active Low)
<b>RE#</b>	Read Enable (Active Low)
<b>WE#</b>	Write Enable (Active Low)
<b>CLE</b>	Command Latch Enable
<b>ALE</b>	Address Latch Enable
<b>WP#</b>	Write Protect (Active Low)
<b>PT</b>	PT (Protection) pin connecting to high for entire chip protected and enabling the Block Protection. A weak pull-down internally.
<b>R/B#</b>	Ready/Busy (Open Drain)
<b>VSS</b>	Ground
<b>VCC</b>	Power Supply for Device Operation
<b>NC</b>	Not Connected Internally

## PIN FUNCTIONS

The MX30LFxG28AD device is a sequential access memory that utilizes multiplexing input of Command/Address/Data.

### I/O PORT: I/O7 - I/O0

The I/O7 to I/O0 pins are for address/command input and data output to/from the device.

### CHIP ENABLE: CE#

The device goes into low-power Standby Mode when CE# goes high during a read operation and not at busy stage.

The CE# goes low to enable the device to be ready for standard operation. When the CE# goes high, the device is deselected. However, when the device is at busy stage, the device will not go to standby mode when CE# pin goes high.

### READ ENABLE: RE#

The RE# (Read Enable) allows the data to be output by a t<sub>REA</sub> time after the falling edge of RE#. The internal address counter is automatically increased by one at the falling edge of RE#.

### WRITE ENABLE: WE#

When the WE# goes low, the address/data/command are latched at the rising edge of WE#.

### COMMAND LATCH ENABLE: CLE

The CLE controls the command input. When the CLE goes high, the command data is latched at the rising edge of the WE#.

### ADDRESS LATCH ENABLE: ALE

The ALE controls the address input. When the ALE goes high, the address is latched at the rising edge of WE#.

### WRITE PROTECT: WP#

The WP# signal keeps low and then the memory will not accept the program/erase operation. It is recommended to keep WP# pin low during power on/off sequence. Please refer to the waveform of "Power On/Off Sequence".

### READY/Busy: R/B#

The R/B# is an open-drain output pin. The R/B# outputs the ready/busy status of read/program/erase operation of the device. When the R/B# is at low, the device is busy for read or program or erase operation. When the R/B# is at high, the read/program/erase operation is finished.

Please refer to **Section 8-1** for details.

### PT: Protection

When the PT pin is high at power on, the whole chip is protected even the WP# is at high; the un-protection procedure (through BP bits setting) is necessary before any program/erase operation. When the PT pin is connected to low or floating, the function of block protection is disabled.

#### 4. BLOCK DIAGRAM

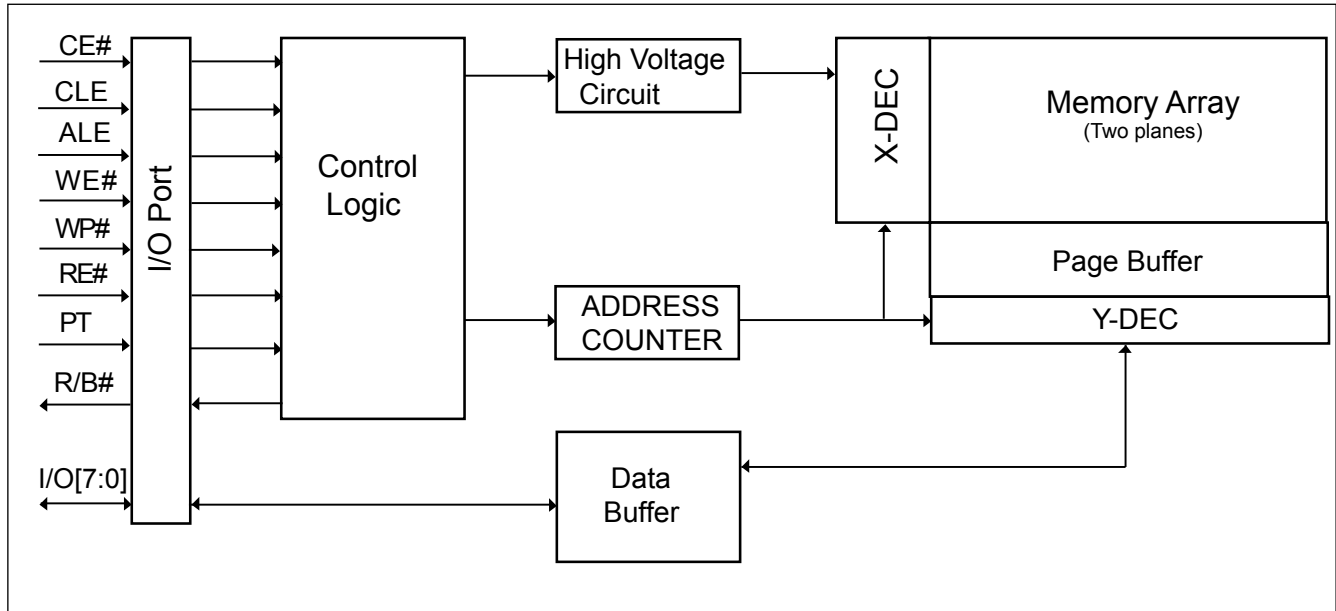

## 5. SCHEMATIC CELL LAYOUT AND ADDRESS ASSIGNMENT

MX30LFxG28AD NAND device is divided into two planes, and each plane has thousands of blocks, which is composed by 64 pages of (2,048+128) byte for 1Gb/2Gb or (4,096+256) byte for 4G. Each page has an additional 128-byte(for 1Gb/2Gb) or 256-byte(for 4Gb) for ECC and other purposes. The device has an on-chip buffer of 2,176-byte (for 1Gb/2Gb) and 4,352-byte (for 4Gb) for data load and access. Each 2K-byte (for 1Gb/2Gb) or 4K-byte (for 4Gb) page has the two area, one is the main area which is 2048-byte(for 1Gb/2Gb) or 4096-byte (for 4Gb) and the other is spare area which is 128-byte(for 1Gb/2Gb) or 256-byte(for 4Gb).

There are four address cycles (for 1Gb) or five address cycles (for 2Gb/4Gb) for the address allocation, please refer to the tables below.

**Table 1-1. Address Allocation (For 1G)**

Addresses	I/O7	I/O6	I/O5	I/O4	I/O3	I/O2	I/O1	I/O0
Column address - 1st cycle	A7	A6	A5	A4	A3	A2	A1	A0
Column address - 2nd cycle	L	L	L	L	A11	A10	A9	A8
Row address - 3rd cycle	A19	A18	A17	A16	A15	A14	A13	A12
Row address - 4th cycle	A27	A26	A25	A24	A23	A22	A21	A20

**Table 1-2. Address Allocation (For 2G)**

Addresses	I/O7	I/O6	I/O5	I/O4	I/O3	I/O2	I/O1	I/O0
Column address - 1st cycle	A7	A6	A5	A4	A3	A2	A1	A0
Column address - 2nd cycle	L	L	L	L	A11	A10	A9	A8
Row address - 3rd cycle	A19	A18 <sup>1</sup>	A17	A16	A15	A14	A13	A12
Row address - 4th cycle	A27	A26	A25	A24	A23	A22	A21	A20
Row address - 5th cycle	L	L	L	L	L	L	L	A28

**Notes:**

- 1: A18 is the plane selection.
- 2: A[10:8] must be 0 when A11 value is 1

**Table 1-3. Address Allocation (For 4G)**

Addresses	I/O7	I/O6	I/O5	I/O4	I/O3	I/O2	I/O1	I/O0
Column address - 1st cycle	A7	A6	A5	A4	A3	A2	A1	A0
Column address - 2nd cycle	L	L	L	A12	A11	A10	A9	A8
Row address - 3rd cycle	A20	A19 <sup>1</sup>	A18	A17	A16	A15	A14	A13
Row address - 4th cycle	A28	A27	A26	A25	A24	A23	A22	A21
Row address - 5th cycle	L	L	L	L	L	L	L	A29

**Notes:**

- 1: A19 is the plane selection.
- 2: The A[11:8] must be 0 when the A12 value is 1.

## 6. DEVICE OPERATIONS

### 6-1. Address Input/Command Input/Data Input

Address input bus operation is for address input to select the memory address. The command input bus operation is for giving command to the memory. The data input bus is for data input to the memory device.

**Figure 2. AC Waveforms for Command / Address / Data Latch Timing**

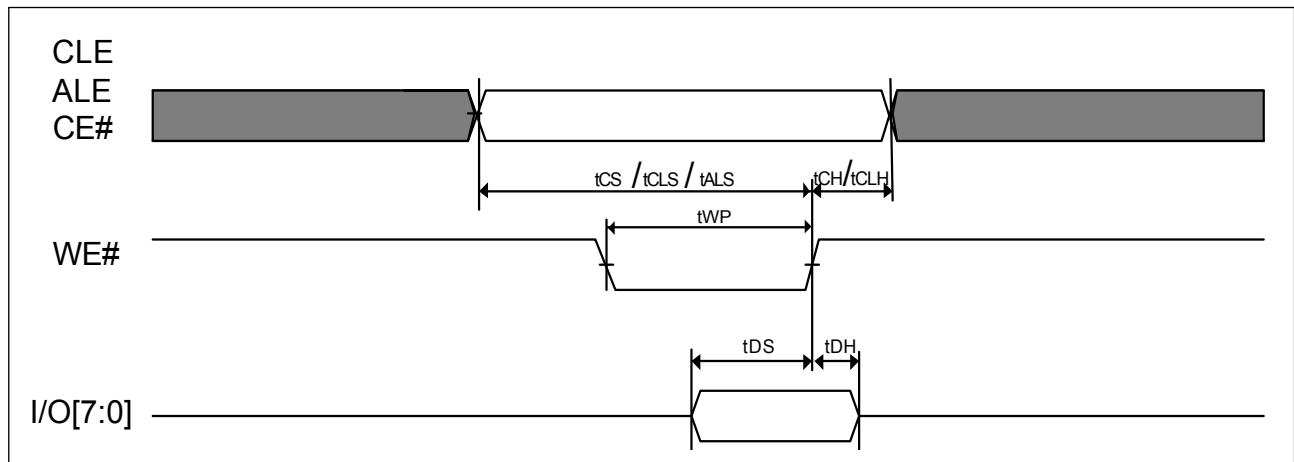

**Figure 3. AC Waveforms for Address Input Cycle**

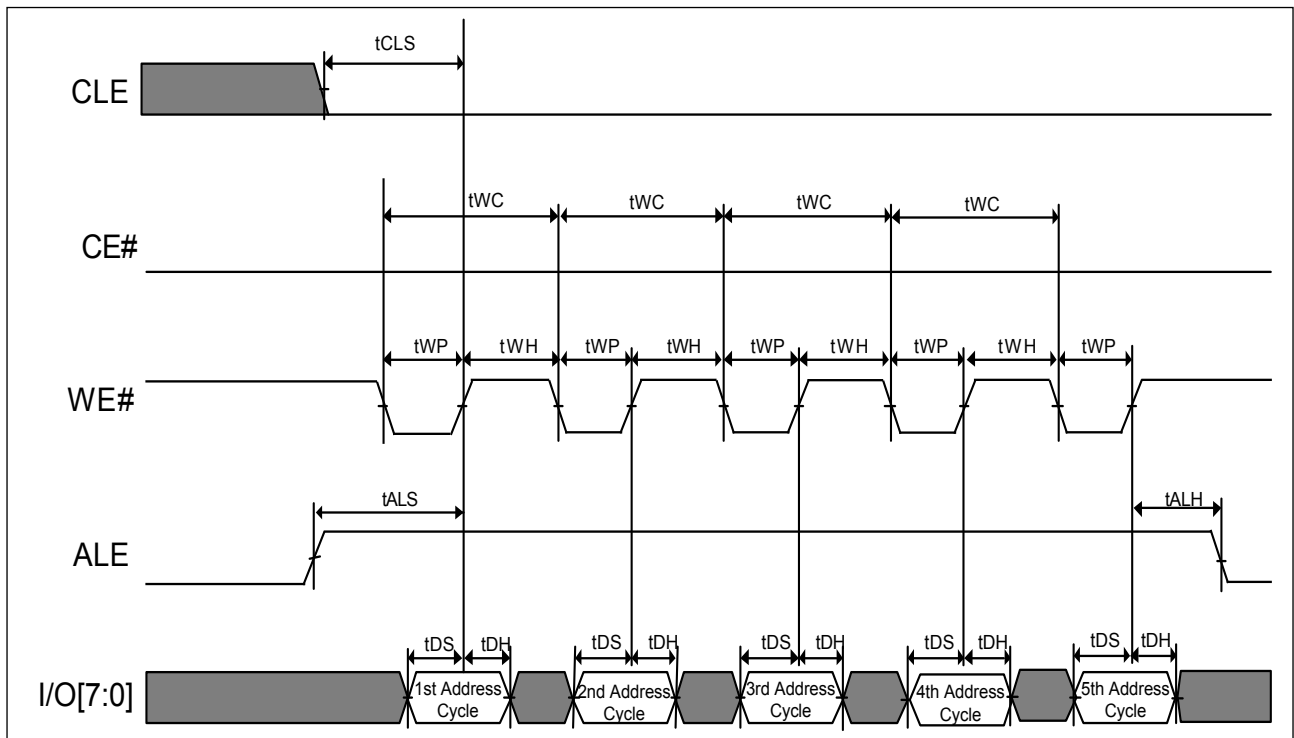

**Note:** The Address cycle is four for 1Gb.

Figure 4. AC Waveforms for Command Input Cycle

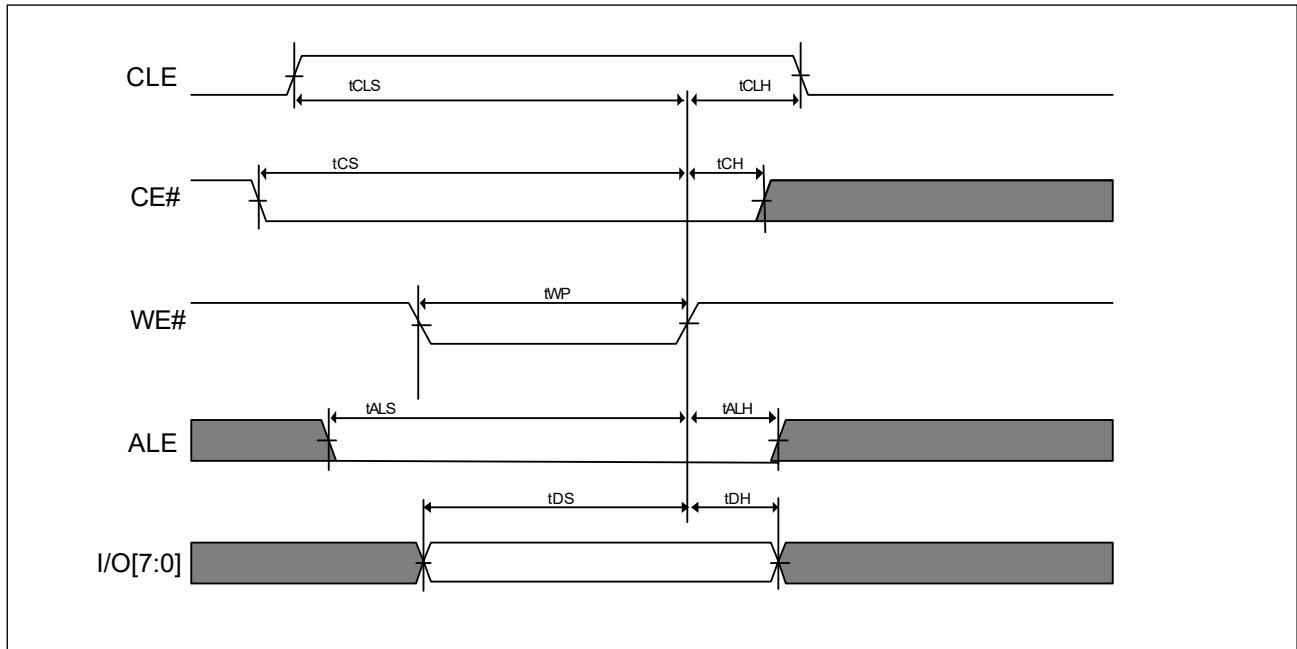
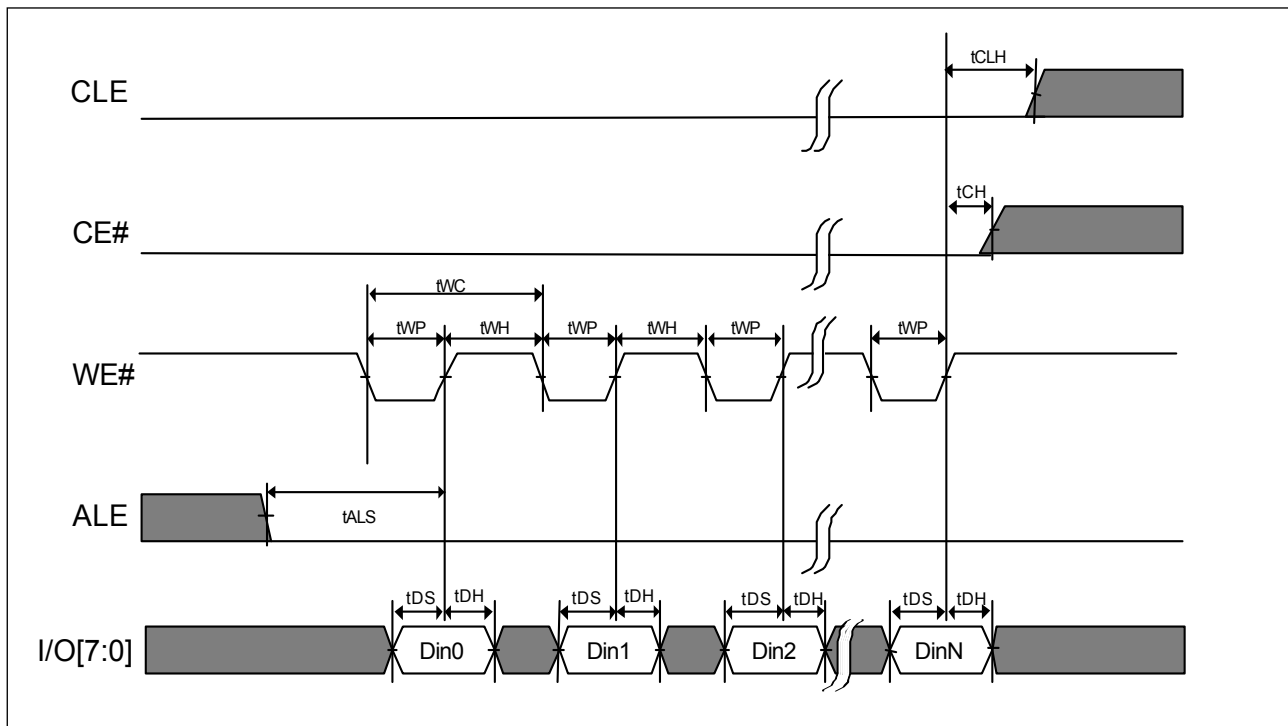

Figure 5. AC Waveforms for Data Input Cycle





## 6-2. Page Read

The MX30LFxG28AD array is accessed in page of 2,176-byte (for 1Gb/2Gb) and 4,352-byte (for 4Gb). External reads begins after the R/B# pin goes to READY.

The device supports "Power-on Read" function, after power up, the device will automatically load the data of the 1st page of 1st block from array to cache. The host micro-controller may directly read the 1st page of 1st block data from the cache buffer.

The Read operation may be initiated by writing the 00h command and giving the address (column and row address) and being confirmed by the 30h command, the MX30LFxG28AD begins the internal read operation and the chip enters busy state. The data can be read out in sequence after the chip is ready. Refer to the waveform for Read Operation as below.

If the host side uses a sequential access time ( $t_{RC}$ ) of less than 30ns, the data can be latched on the next falling edge of RE# as the waveform of EDO mode ("Figure 9-2. AC Waveforms for Sequential Data Out Cycle (After Read) - EDO Mode").

To access the data in the same page randomly, a command of 05h may be written and only column address following and then confirmed by E0h command.

**Figure 6. AC Waveforms for Read Cycle**

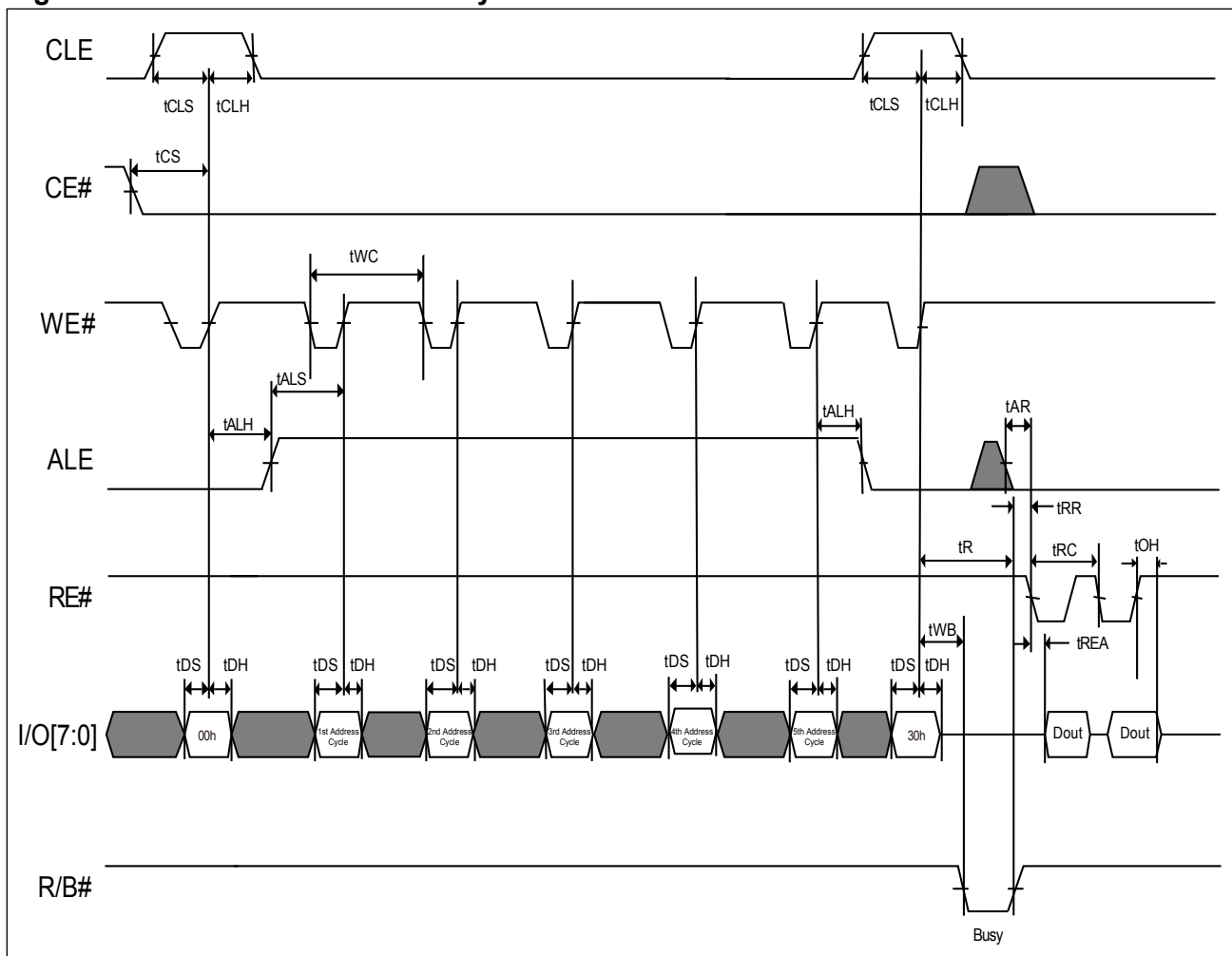

**Note:** The Address cycle is four for 1Gb.

**Figure 7. AC Waveforms for Read Operation (Intercepted by CE#)**

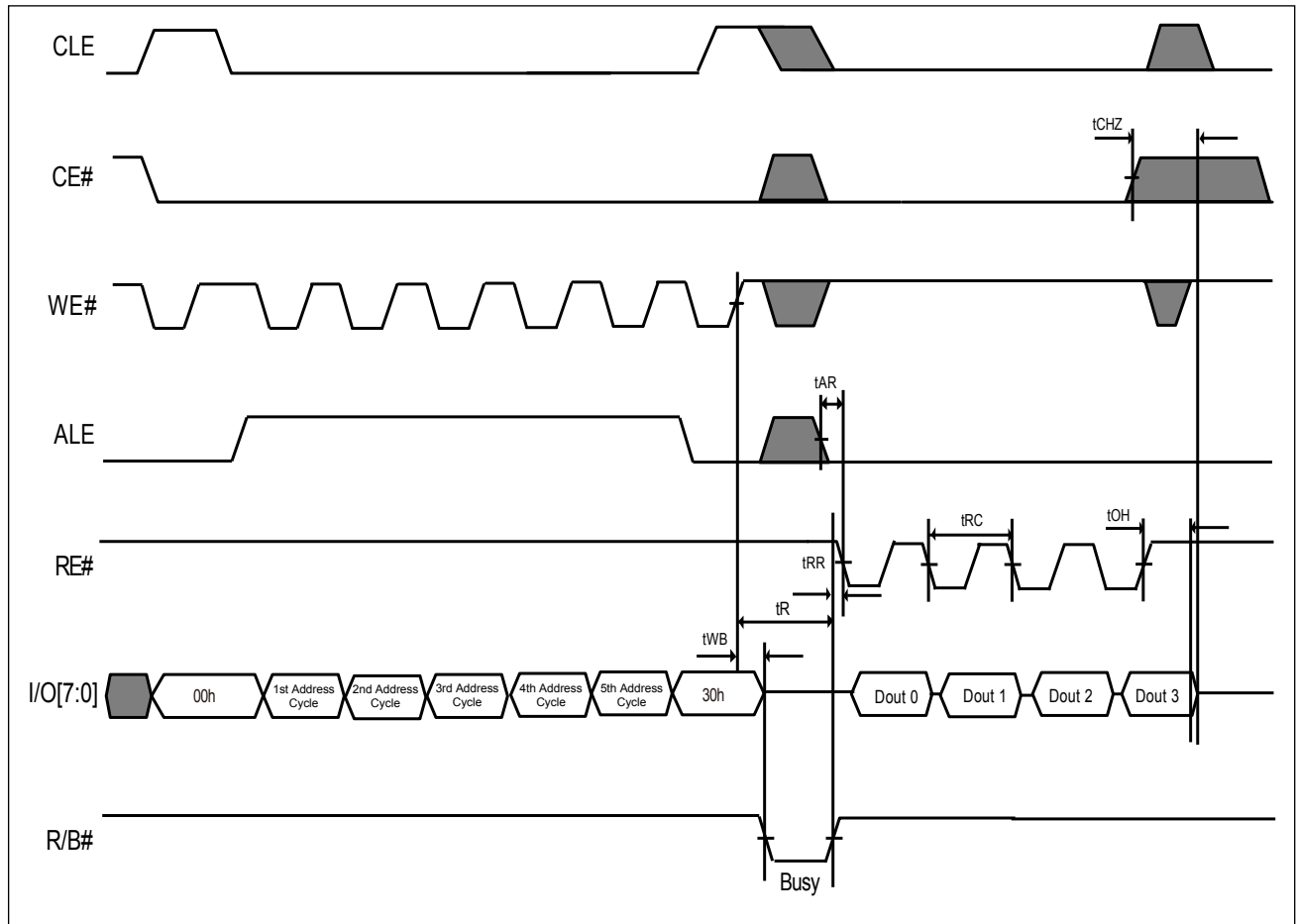

**Note:** The Address cycle is four for 1Gb.

**Figure 8. AC Waveforms for Read Operation (with CE# Don't Care)**

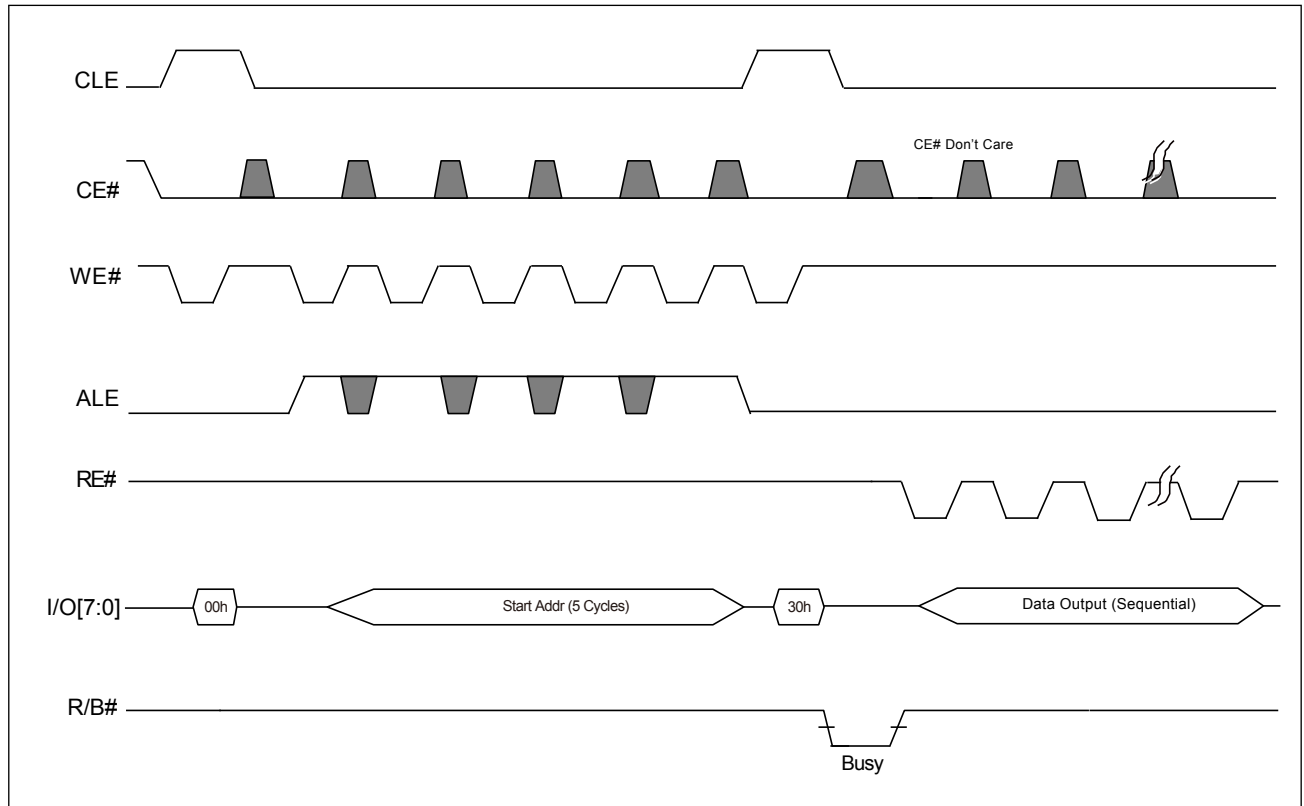

**Note 1:** The CE# "Don't Care" feature may simplify the system interface, which allows controller to directly download the code from flash device, and the CE# transitions will not stop the read operation during the latency time.

**Note 2:** The Address cycle is four for 1Gb.

**Figure 9-1. AC Waveforms for Sequential Data Out Cycle (After Read)**

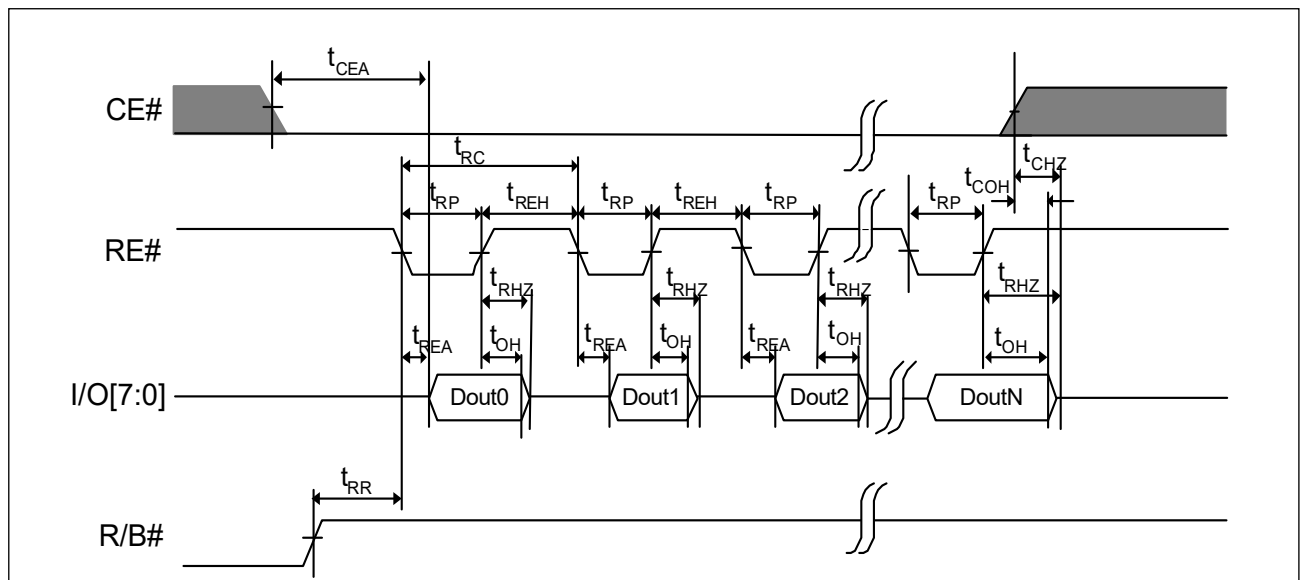

Figure 9-2. AC Waveforms for Sequential Data Out Cycle (After Read) - EDO Mode

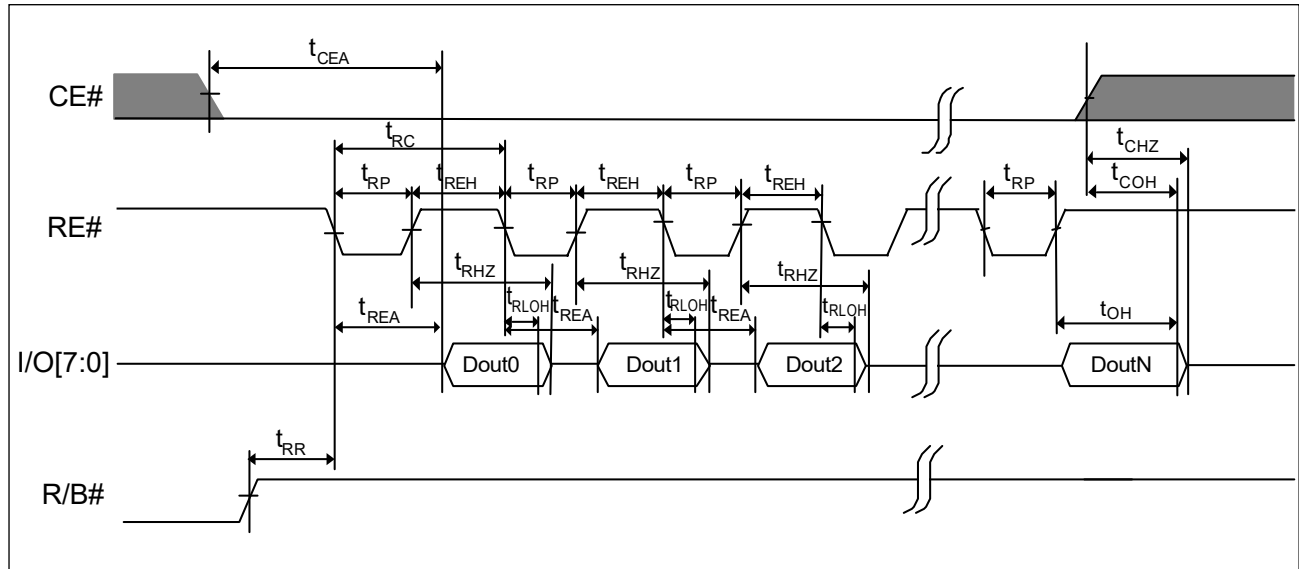
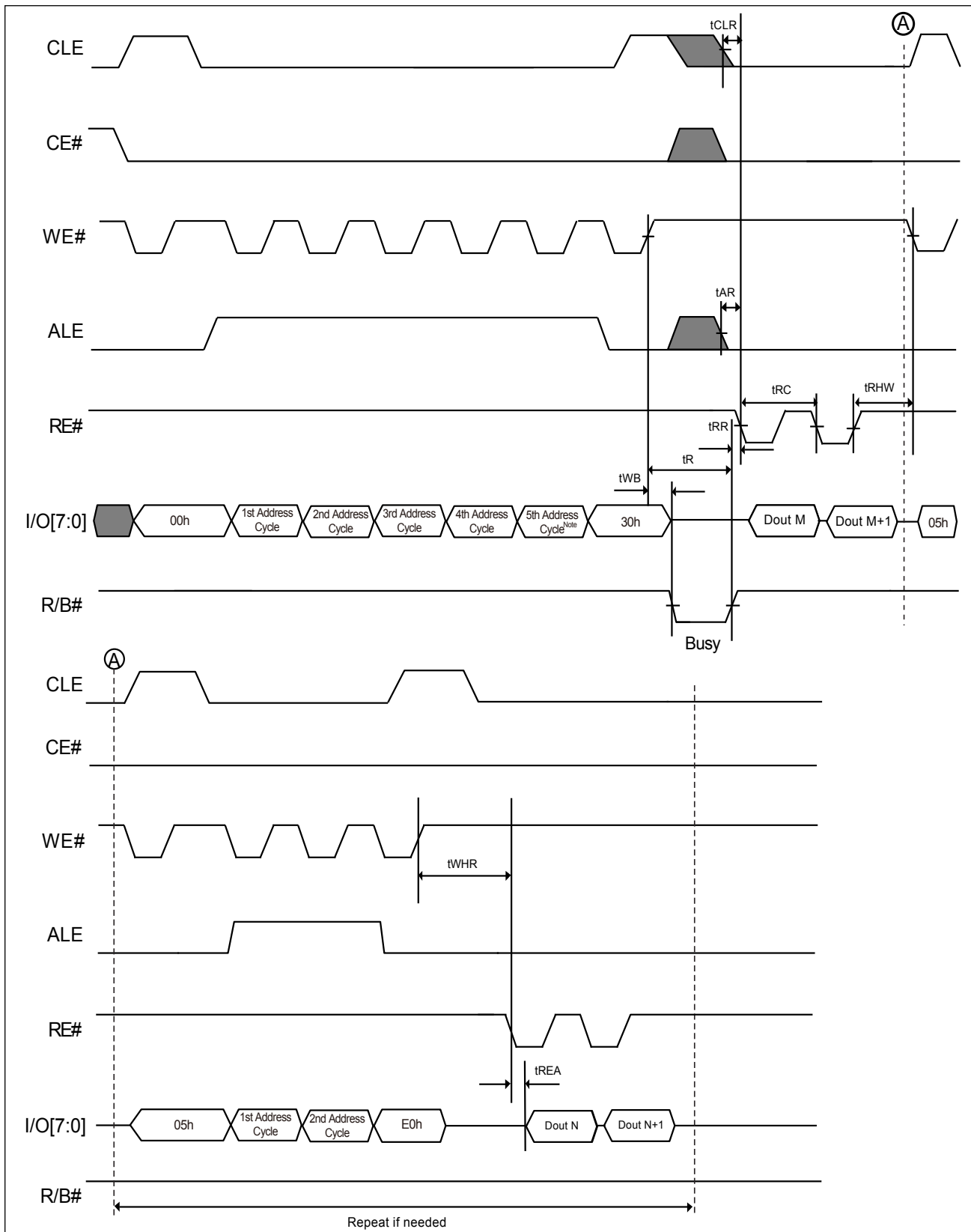

Figure 10. AC Waveforms for Random Data Output



**Note:** The Address cycle is four for 1Gb.

### 6-3. Cache Read Sequential

The cache read sequential operation is for throughput enhancement by using the internal cache buffer. It allows the consecutive pages to be read-out without giving next page address, which reduces the latency time from  $t_R$  to  $t_{RCBSY}$  between pages or blocks. While the data is read out on one page, the data of next page can be read into the cache buffer.

After writing the 00h command, the column and row address should be given for the start page selection, and followed by the 30h command for address confirmation. After that, the CACHE READ operation starts after a latency time  $t_R$  and following a 31h command with the latency time of  $t_{RCBSY}$ , the data can be read-out sequentially from 1<sup>st</sup> column address (A[11:0]=00h) without giving next page address input. The 31h command is necessary to confirm the next cache read sequential operation and followed by a  $t_{RCBSY}$  latency time before next page data is necessary. The CACHE READ SEQUENTIAL command is also valid for the consecutive page cross block.

The random data out (05h-E0h) command set is available to change the column address of the current page data in the cache register.

The user can check the chip status by the following method:

- R/B# pin ("0" means the data is not ready, "1" means the user can read the data)
- Status Register (SR[6] functions the same as R/B# pin, SR[5] indicates the internal chip operation, "0" means the chip is in internal operation and "1" means the chip is idle.) Status Register can be checked after the Read Status command (70h) is issued. Command 00h should be given to return to the cache read sequential operation.

To confirm the last page to be read-out during the cache read sequential operation, a 3Fh command is needed to replace the 31h command prior to the last data-out.

Figure 11-1. AC Waveforms for Cache Read Sequential

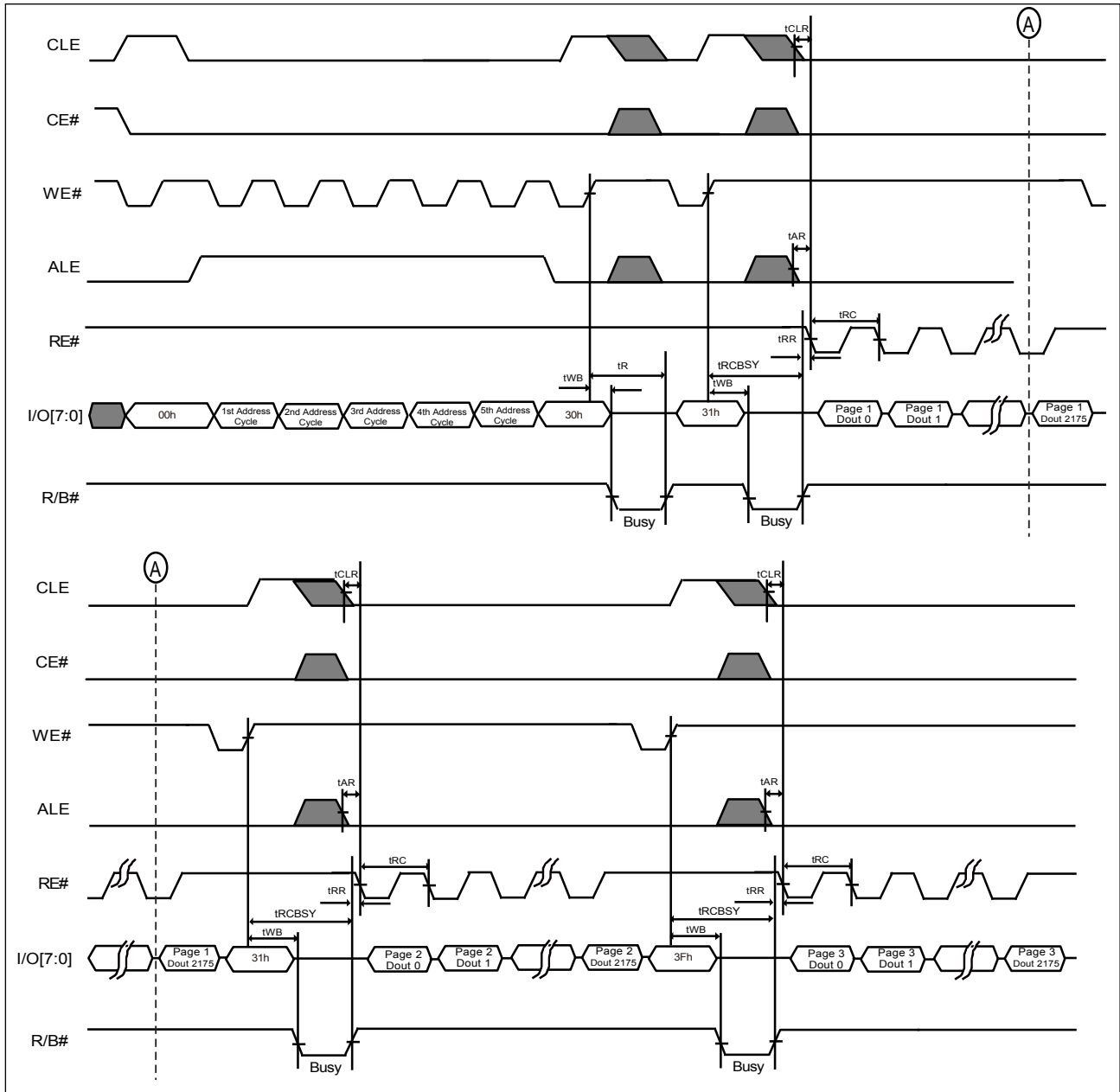

**Note:** The Address cycle is four for 1Gb.

## 6-4. Cache Read Random

The main difference from the Cache Read Sequential operation is the Cache Read Random operation may allow the random page to be read-out with cache operation not just for the consecutive page only.

After writing the 00h command, the column and row address should be given for the start page selection, and followed by the 30h command for address confirmation. The column address is ignored in the cache read random operation. And then, the CACHE READ RANDOM operation starts after a latency time  $t_R$  and following a 00h command with the selected page address and following a 31h command, the data can be read-out after the latency time of  $t_{RCBSY}$ . After the previous selected page data out, a new selected page address can be given by writing the 00h-31h command set again. The CACHE READ RANDOM command is also valid for the consecutive page cross block.

The random data out (05h-E0h) command set is available to change the column address of the current page data in the cache register.

The user can check the chip status by the following method:

- R/B# pin ("0" means the data is not ready, "1" means the user can read the data)
- Status Register can be checked after the Read Status command (70h) is issued. (SR[6] behaves the same as R/B# pin, SR[5] indicates the internal chip operation, "0" means the chip is in internal operation and "1" means the chip is idle.) Command 00h should be given to return to the cache read operation.

To confirm the last page to be read-out during the cache read operation, a 3Fh command is needed to replace the 31h command prior to the last data-out.



Figure 11-2. AC Waveforms for Cache Read Random

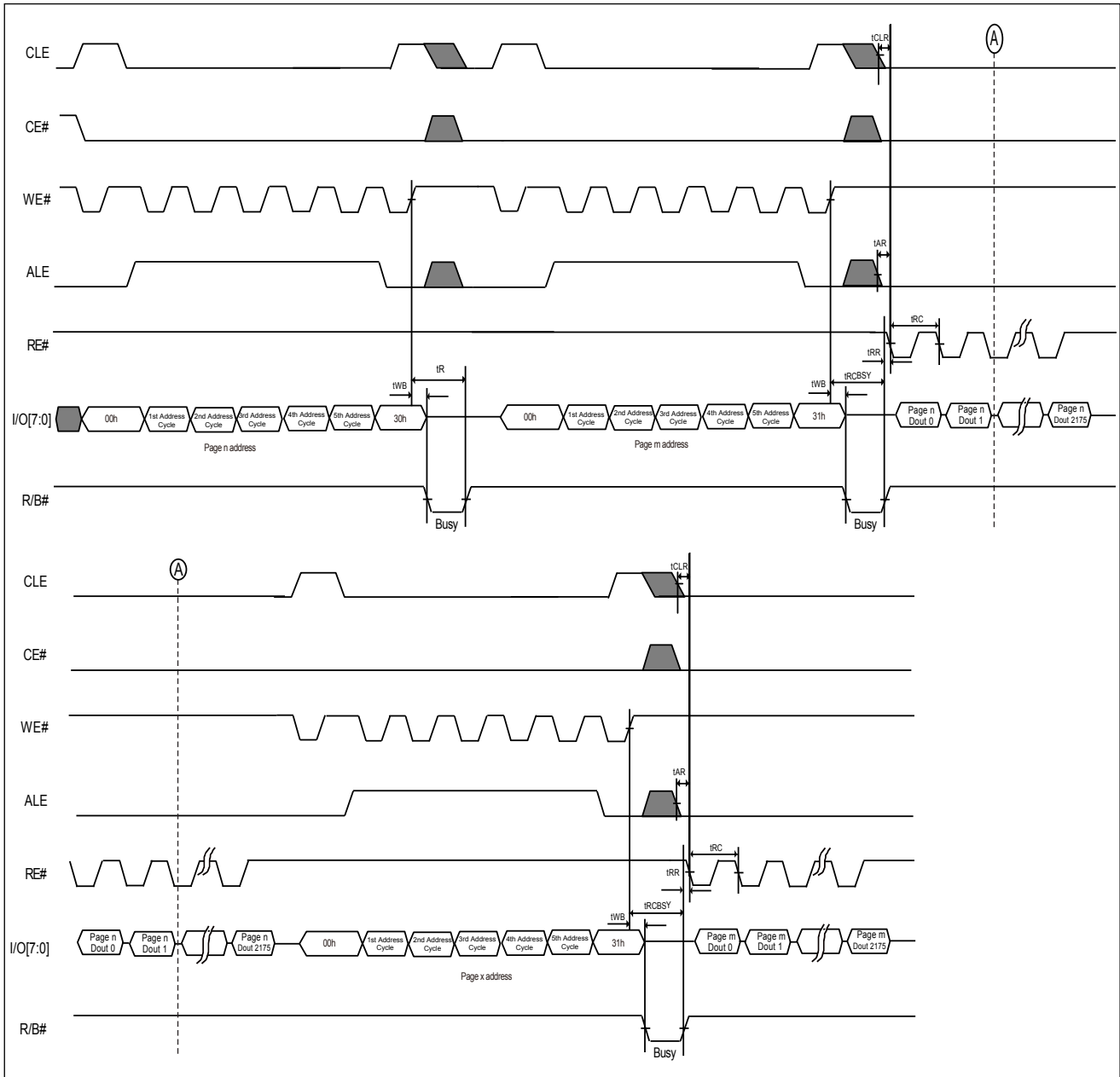

**Note:** The Address cycle is four for 1Gb.

## 6-5. Page Program

The memory is programmed by page, which is 2,176-byte (for 1Gb/2Gb) and 4,352-byte (for 4Gb). After Program load command (80h) is issued and the row and column address is given, the data will be loaded into the chip sequentially. Random Data Input command (85h) allows multi-data load in non-sequential address. After data load is complete, program confirm command (10h) is issued to start the page program operation. The page program operation in a block should start from the low address to high address. Partial program in a page is allowed up to 4 times. However, the random data input mode for programming a page is allowed and number of times is not limited.

The status of the program completion can be detected by R/B# pin or Status register bit SR[6].

The program result is shown in the chip status bit (SR[0]). SR[0] = 1 indicates the Page Program is not successful and SR[0] = 0 means the program operation is successful.

During the Page Program progressing, only the read status register command and reset command are accepted, others are ignored.

**Figure 12. AC Waveforms for Program Operation after Command 80H**

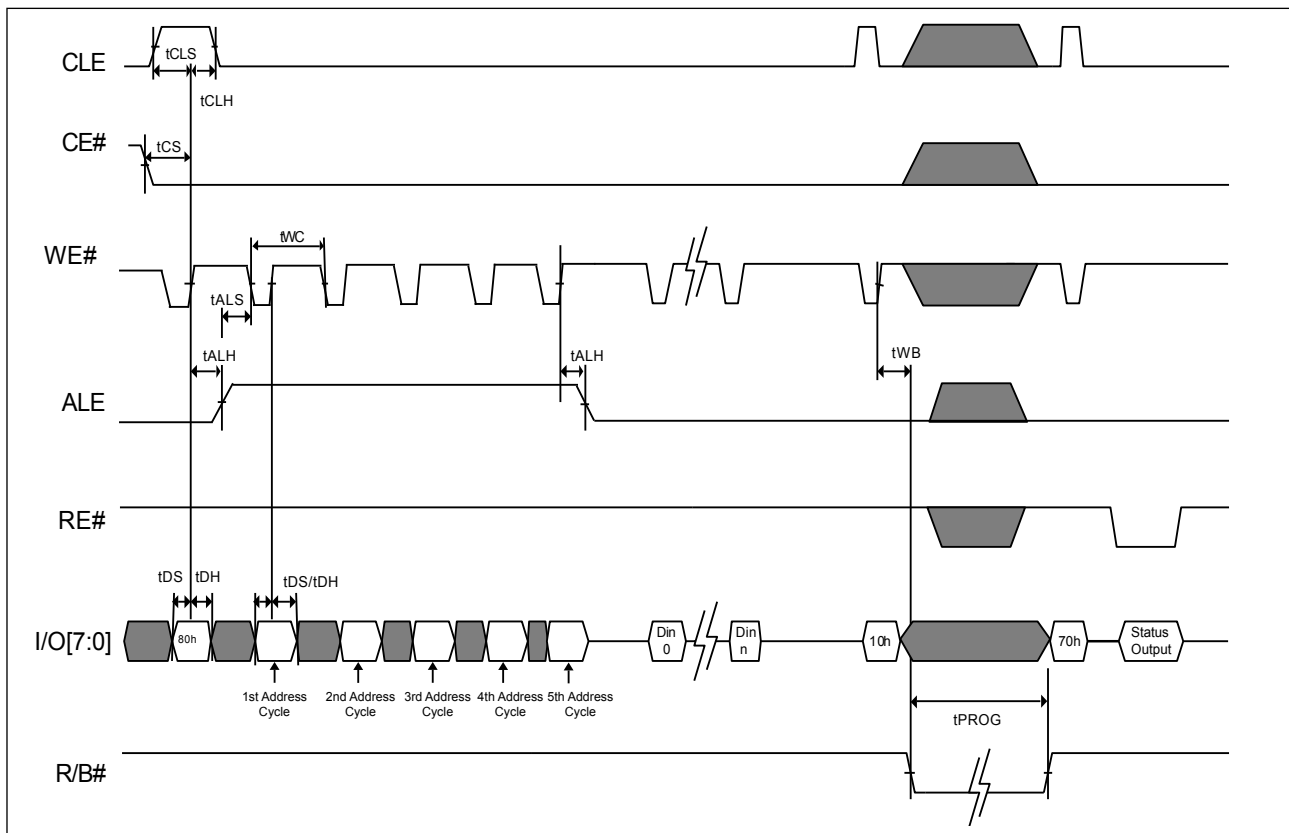

**Note:** The Address cycle is four for 1Gb.

**Figure 13. AC Waveforms for Random Data In (For Page Program)**

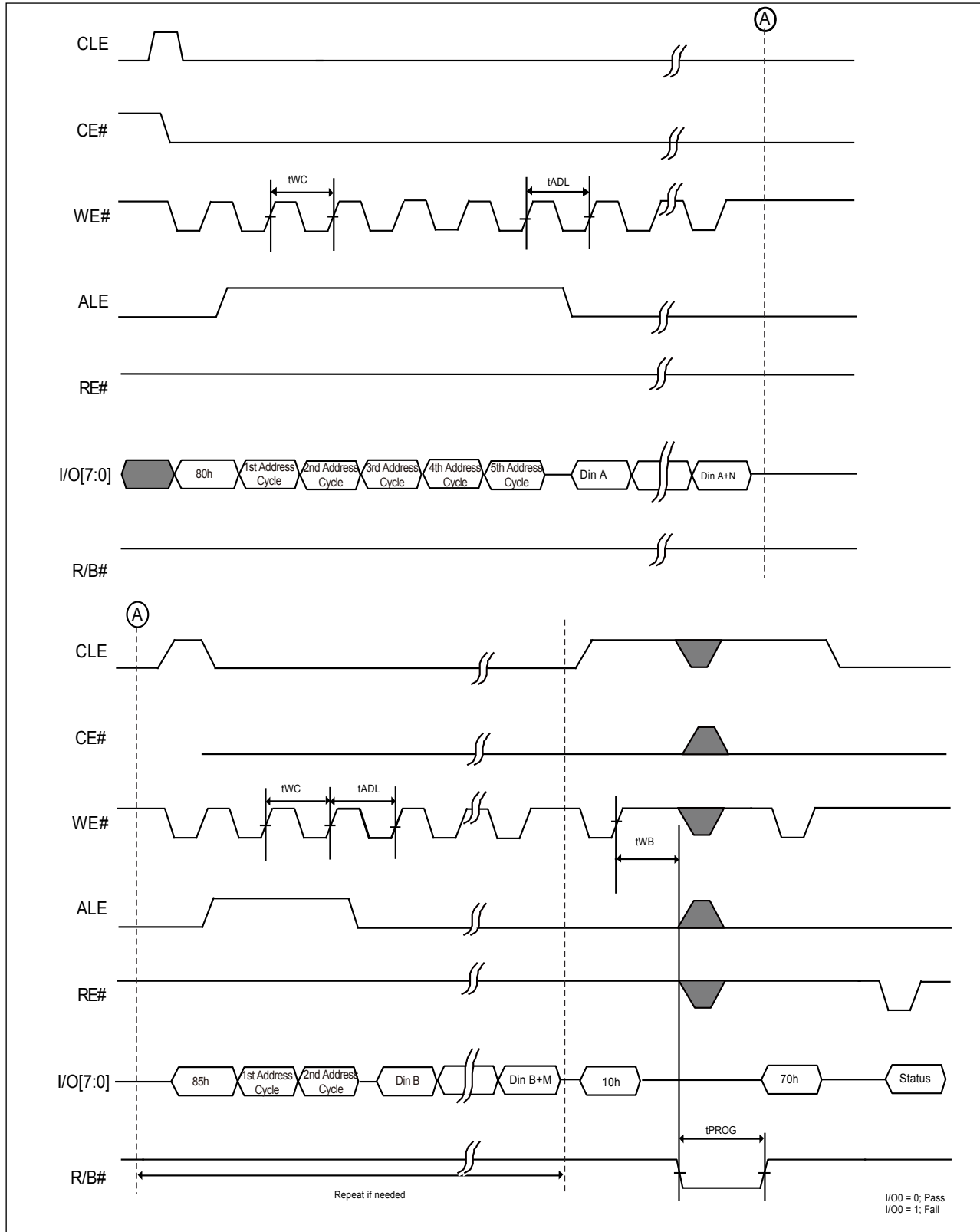

**Note 1:** Random Data In is also supported in cache program.

**Note 2:** The Address cycle is four for 1Gb.

**Figure 14. AC Waveforms for Program Operation with CE# Don't Care**

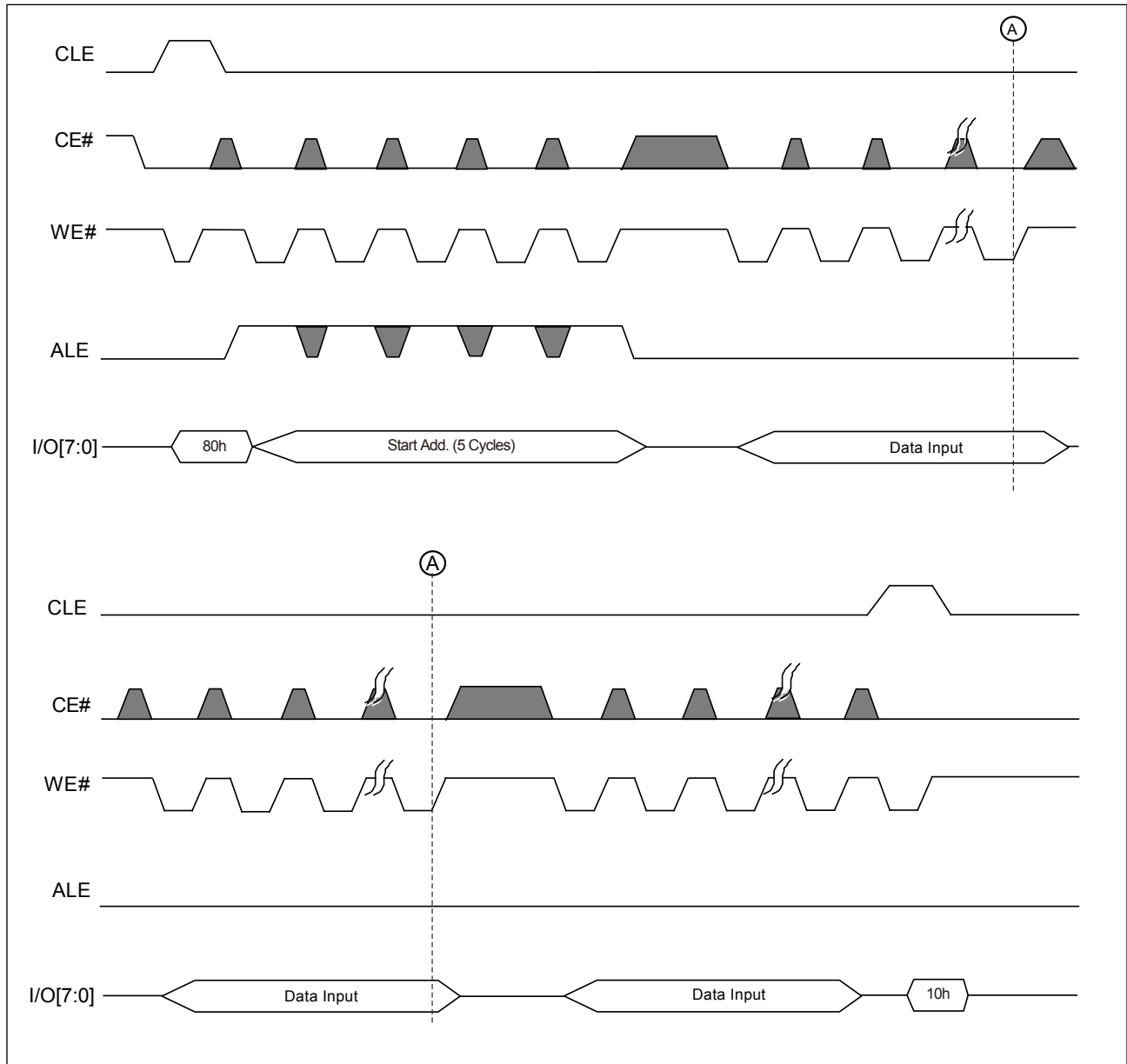

**Note 1:** The CE# "Don't Care" feature may simplify the system interface, which allows the controller to directly write data into flash device, and the CE# transitions will not stop the program operation during the latency time.

**Note 2:** The Address cycle is four for 1Gb.

## 6-6. Cache Program

The cache program feature enhances the program performance by using the cache buffer of 2,176 byte (for 1Gb/2Gb) and 4,352 byte (for 4Gb). The serial data can be input to the cache buffer while the previous data stored in the buffer are programming into the memory cell. Cache Program command sequence is almost the same as page program command sequence. Only the Program Confirm command (10h) is replaced by cache Program command (15h).

After the Cache Program command (15h) is issued. The user can check the status by the following methods.

- R/B# pin
- Cache Status Bit (SR[6] = 0 indicates the cache is busy; SR[6] = 1 means the cache is ready).

The user can issue another Cache Program Command Sequence after the Cache is ready. The user can always monitor the chip state by Ready/Busy Status Bit (SR[5]). The user can issue either program confirm command (10h) or cache program command (15h) for the last page if the user monitor the chip status by issuing Read Status Command (70h).

However, if the user only monitors the R/B# pin, the user needs to issue the program confirm command (10h) for the last page.

The user can check the Pass/Fail Status through P/F Status Bit (SR[0]) and Cache P/F Status Bit (SR[1]). SR[1] represents Pass/Fail Status of the previous page. SR[1] is updated when SR[6] change from 0 to 1 or Chip is ready. SR[0] shows the Pass/Fail status of the current page. It is updated when SR[5] change from "0" to "1" or the end of the internal programming. For more details, please refer to the related waveforms.

Figure 15-1. AC Waveforms for Cache Program

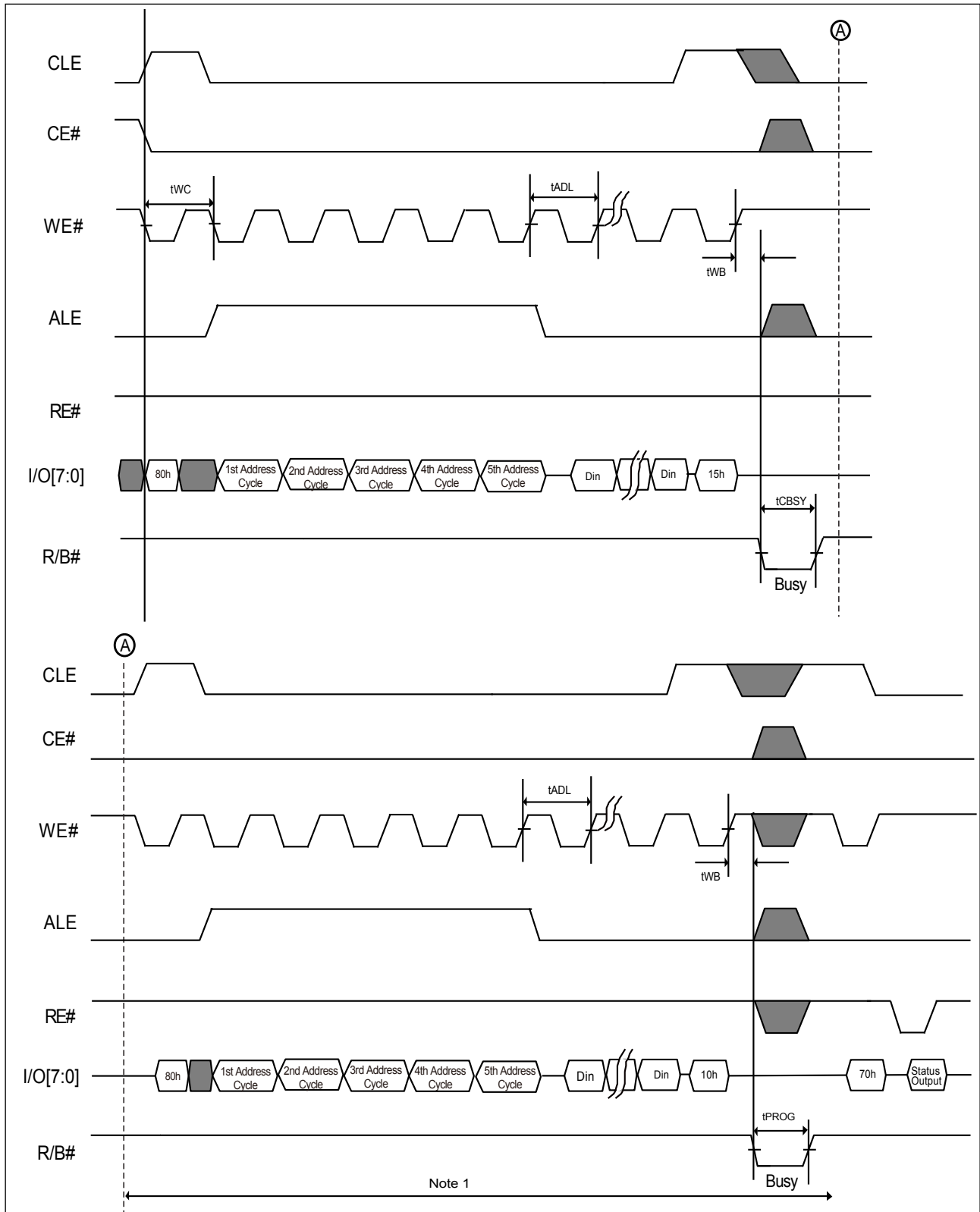

**Note 1:** It indicates the last page Input & Program.

**Note 2:** The Address cycle is four for 1Gb.

**Figure 15-2. AC Waveforms for Sequence of Cache Program**

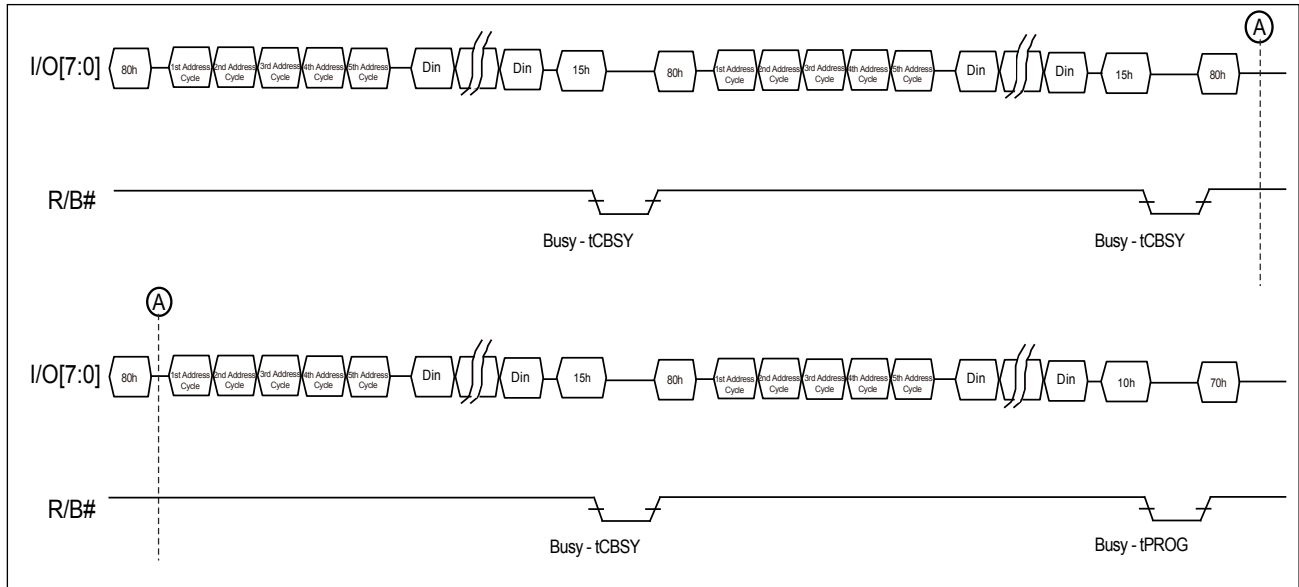

**Note 1:**  $t_{PROG} = Page_{(Last)} \text{ programming time} + Page_{(Last-1)} \text{ programming time} - \text{Input cycle time of command \& address} - \text{Data loading time of page}_{(Last)}$ .

**Note 2:** The Address cycle is four for 1Gb.

## 6-7. Block Erase

The MX30LFxG28AD supports a block erase command. This command will erase a block of 64 pages associated with the most significant address bits.

The completion of the erase operation can be detected by R/B# pin or Status register bit (I/O6). Recommend to check the status register bit I/O0 after the erase operation completes.

During the erasing process, only the read status register command and reset command can be accepted, others are ignored.

**Figure 16. AC Waveforms for Erase Operation**

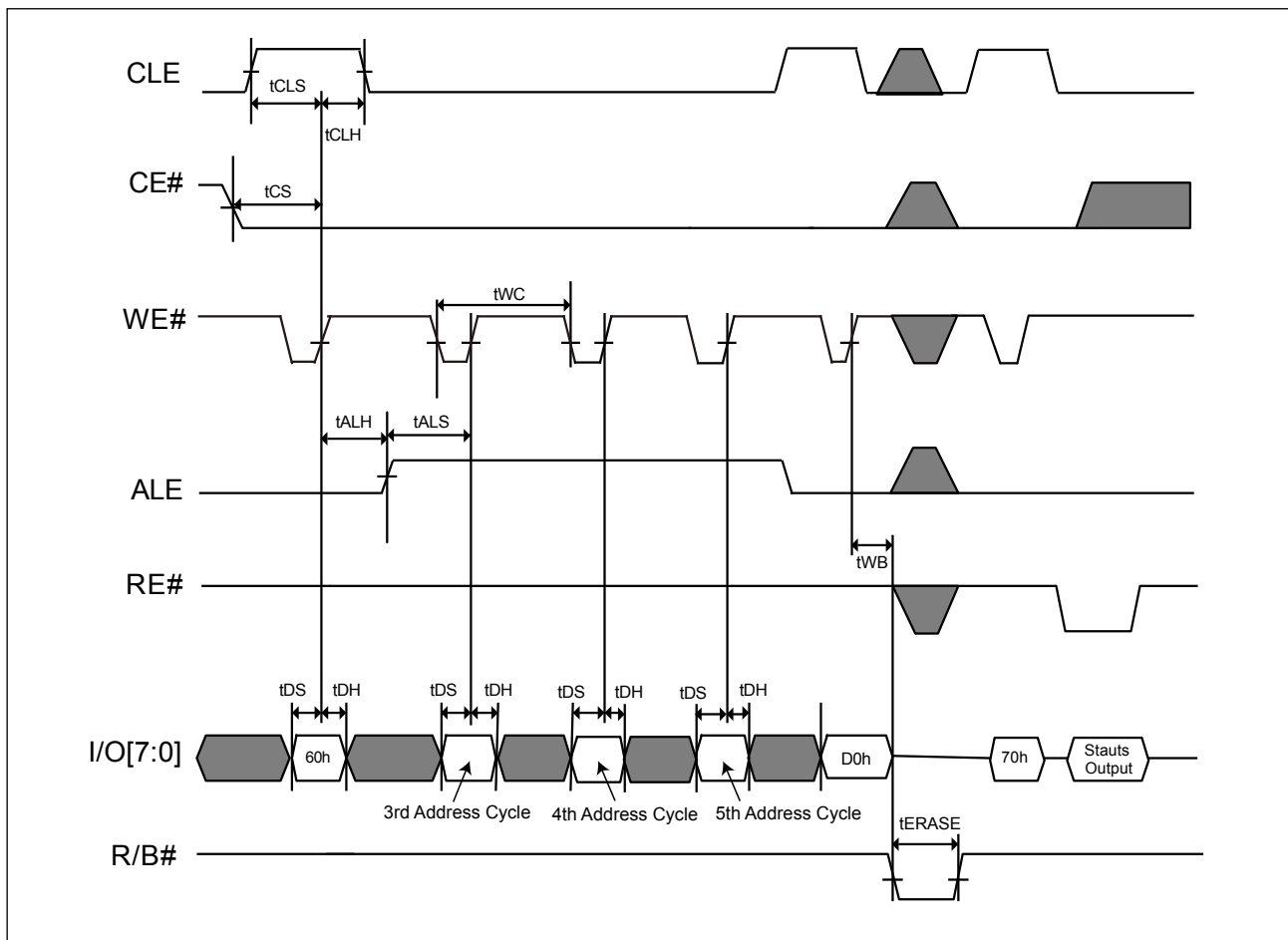

**Note:** The Block Address cycle is 3rd address cycle and 4th address cycle for 1Gb



## 6-8. ID Read

The device contains ID codes that identify the device type and the manufacturer. The ID READ command sequence includes one command Byte (90h), one address byte (00h). The Read ID command 90h may provide the manufacturer ID (C2h) of one-byte and device ID of one-byte, also Byte2, Byte3, Byte4, and Byte5 ID code are followed.

The device support ONFI Parameter Page Read, by sending the ID Read (90h) command and following one byte address (20h), the four-byte data returns the value of 4Fh-4Eh-46h-49h for the ASCII code of "O"- "N"- "F"- "I" to identify the ONFI parameter page.

**Table 2. ID Codes Read Out by ID Read Command 90H**

ID Codes	1Gb, x8, 3V	2Gb, x8, 3V	4Gb, x8, 3V
Byte0-Manufacturer	C2h	C2h	C2h
Byte1: Device ID	F1h	DAh	DCh
Byte2	80h	90h	90h
Byte3	91h	91h	A2h
Byte4	03h	07h	57h
Byte5	03h	03h	03h

**Table 3. The Definition of Byte2-Byte4 of ID Table**

Terms	Description	I/O7	I/O6	I/O5	I/O4	I/O3	I/O2	I/O1	I/O0
<b>Byte 2</b>									
<b>Die Number</b>	1							0	0
	2							0	1
<b>Cell Structure</b>	SLC					0	0		
<b># of Concurrently Programmed page</b>	1			0	0				
	2			0	1				
<b>Interleaved operations between Multiple die</b>	Not supported		0						
<b>Cache Program</b>	Supported	1							
<b>Byte 3</b>									
<b>Page size (Exclude spare)</b>	2KB							0	1
	4KB							1	0
<b>Spare area size (Per 512B)</b>	32B						0		
<b>Block size (Exclude spare)</b>	128KB			0	1				
	256KB			1	0				
<b>Organization</b>	x8		0						
<b>Sequential Read Cycle Time</b>	25ns	0				0			
	20ns	1				0			
<b>Byte 4</b>									
<b>ECC level requirement</b>	8-bit ECC/544B							1	1
<b>#Plane per CE</b>	1					0	0		
	2					0	1		
	4					1	0		
<b>Plane size</b>	1Gb		0	0	0				
	2Gb		1	0	1				
<b>Reserved</b>		0							
<b>Byte 5</b>									
<b>Device Generation</b>	D						0	1	1
<b>Reserved</b>		0	0	0	0	0			

**Figure 17-1. AC Waveforms for ID Read Operation**

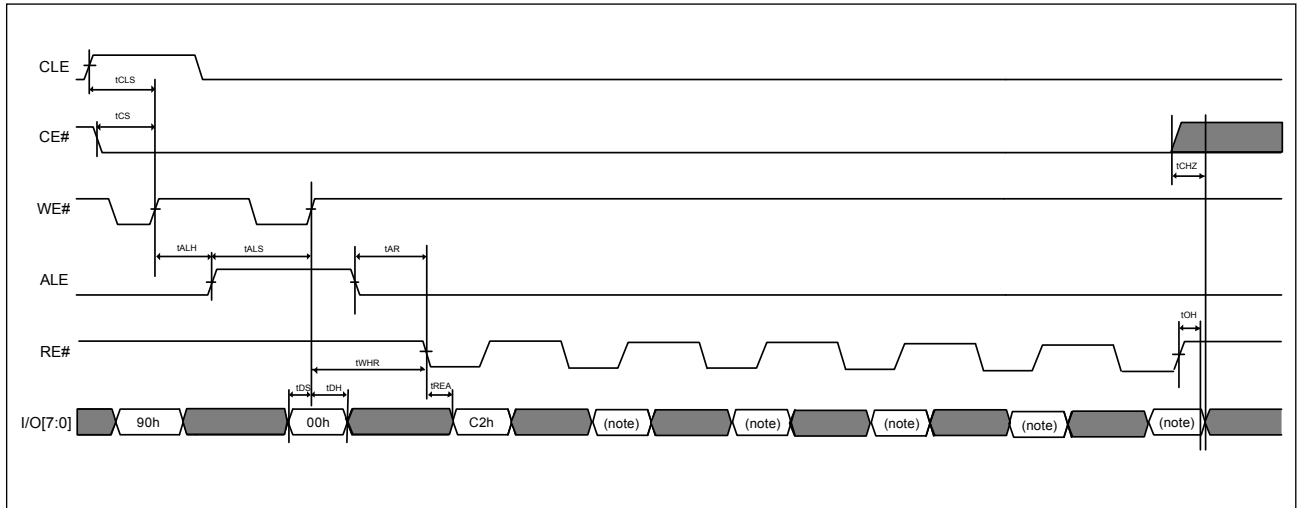

**Note:** Please also refer to "Table 2. ID Codes Read Out by ID Read Command 90H".

**Figure 17-2. AC Waveforms for ID Read (ONFI Identifier) Operation**

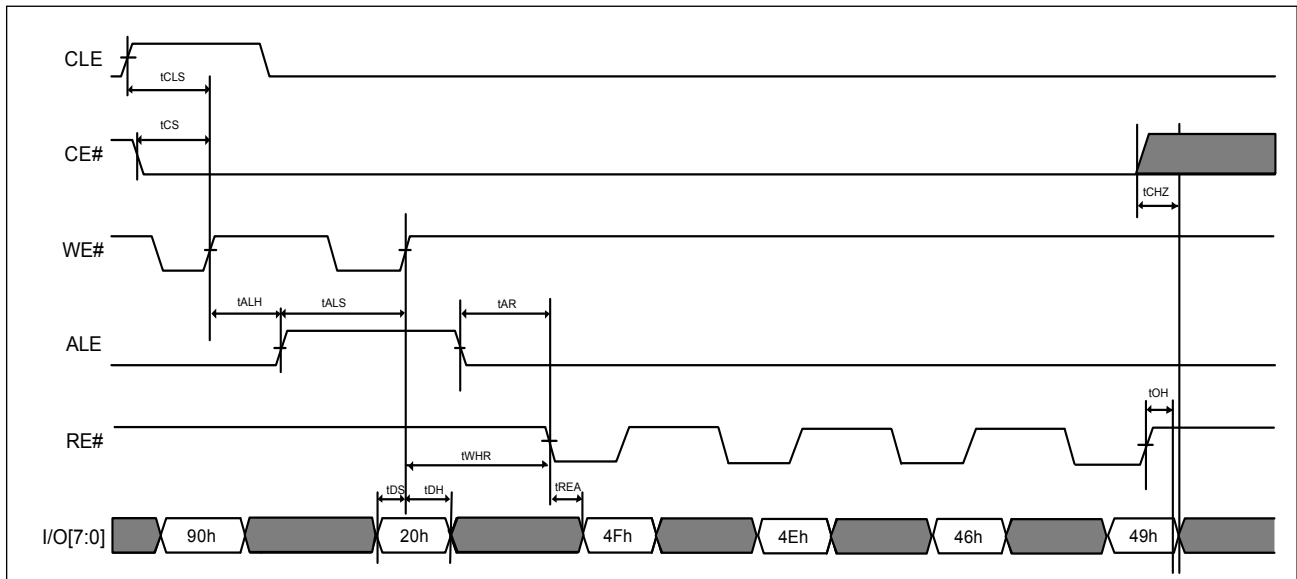

## 6-9. Status Read

The MX30LFxG28AD provides a status register that outputs the device status by writing a command code 70h, and then the I/O pins output the status at the falling edge of CE# or RE# which occurs last. Even though when multiple flash devices are connecting in system and the R/B#pins are common-wired, the two lines of CE# and RE# may be checked for individual devices status separately.

The status read command 70h will keep the device at the status read mode unless next valid command is issued. The resulting information is outlined in "Table 4. Status Output" as below.

**Table 4. Status Output**

Pin	Status	Related Mode	Value	
SR[0]	Chip Status	Page Program, Cache Program (Page N), Block Erase	0: Passed	1: Failed
SR[1]	Cache Program Result	Cache Program (Page N-1)	0: Passed	1: Failed
SR[2-4]	Not Used			
SR[5]	Ready / Busy (For P/E/R Controller)	Cache Program/Cache Read operation, other Page Program/Block Erase/Read are same as I/O6 <sup>(Note 1)</sup>	0: Busy	1: Ready
SR[6]	Ready / Busy	Page Program, Block Erase, Cache Program, Read, Cache Read <sup>(Note 2)</sup>	0: Busy	1: Ready
SR[7]	Write Protect	Page Program, Block Erase, Cache Program	0: Protected	1: Unprotected

**Notes:**

1. During the actual programming operation, the SR[5] is "0" value; however, when the internal operation is completed during the cache mode, the SR[5] returns to "1".
2. The SR[6] returns to "1" when the internal cache is available to receive new data. The SR[6] value is consistent with the R/B#.

The following is an example of a HEX data bit assignment:

**Figure 18. Bit Assignment (HEX Data)**

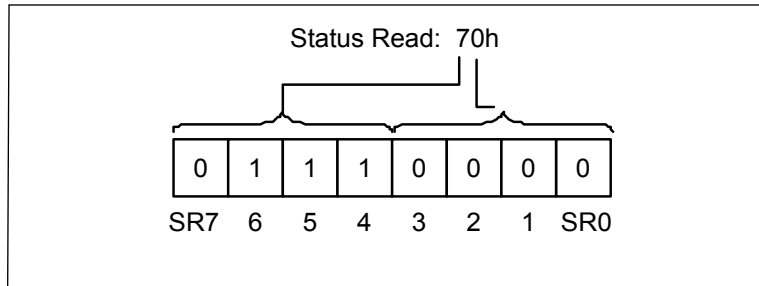

**Figure 19. AC Waveforms for Status Read Operation**

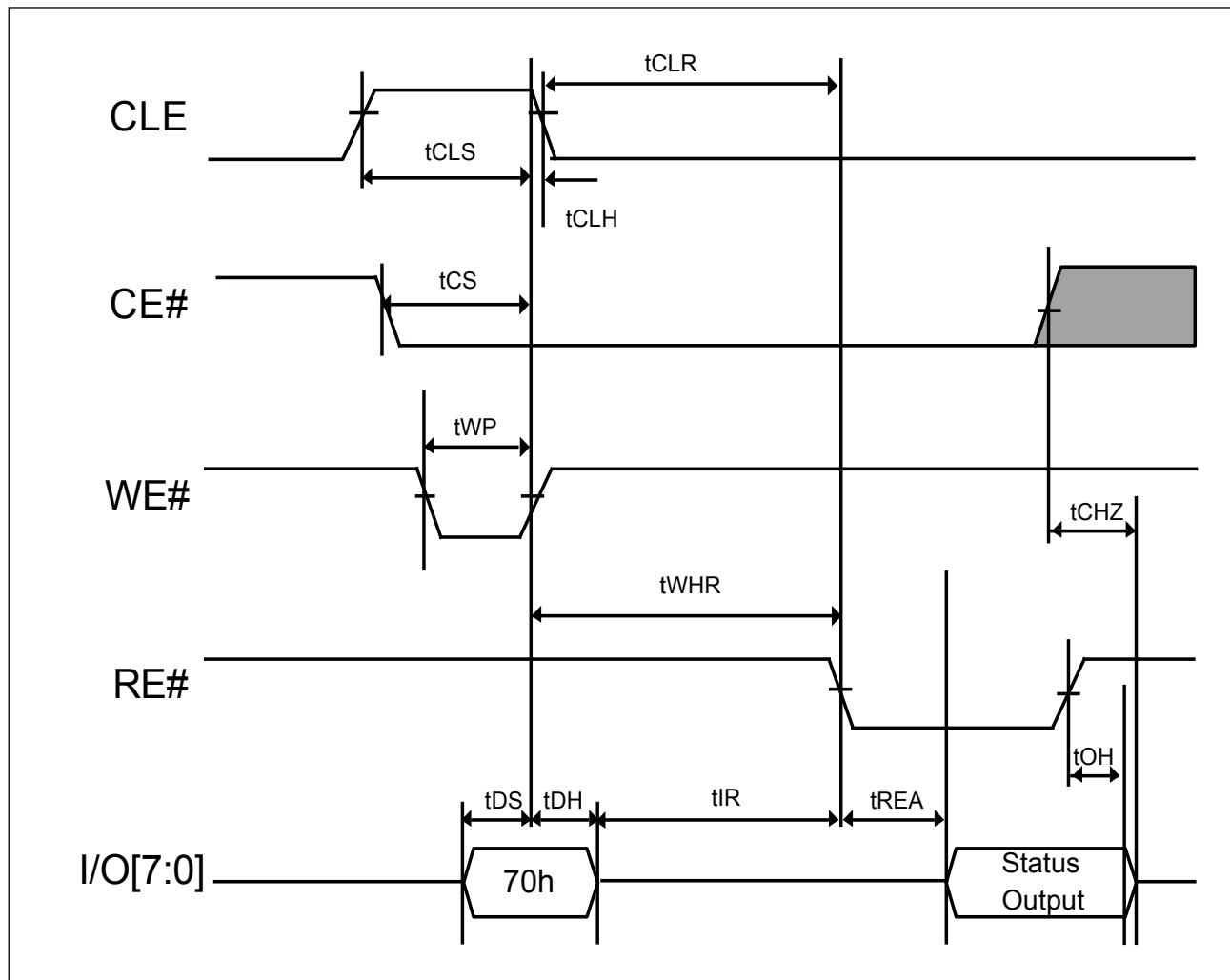

## 6-10. Status Enhance Read (For 2Gb/4Gb)

The MX30LFxG28AD supports the two-plane operation, the Status Enhanced Read command (78h) offers the alternative method besides the Status Read command to get the status of specific plane in the same NAND Flash device. The result information is outlined in "Table 4. Status Output".

The [SR]6 and SR[5] bits are shared with all planes. However, the SR[0], SR[1], SR[3], SR[4] are for the status of specific plane in the row address. The Status Enhanced Read command is not allowed at power-on Reset (FFh) command, OTP enabled operation.

Figure 20. AC Waveforms for Status Enhance Operation

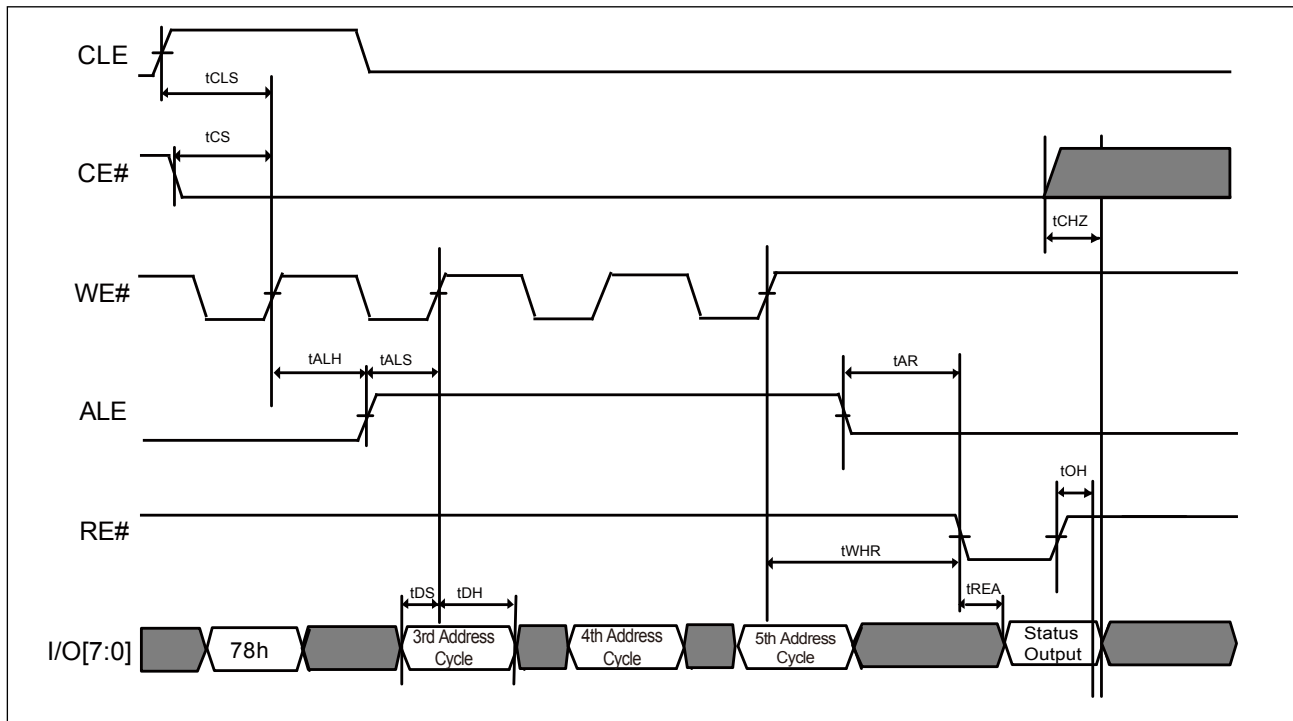

## 6-11. Block Protection Status Read

The Block Protection Status Read command (7Ah) may check the protect/un-protect status of blocks. The status output is shown in "Table 5. Block-Protection Status Output" and the address cycle is referred to "Table 6-1. Address Cycle Definition of Block (1G)", "Table 6-2. Address Cycle Definition of Block (2G)" and "Table 6-3. Address Cycle Definition of Block (4G)".

**Table 5. Block-Protection Status Output**

Block-Protection Status	I/O[7:3]	I/O2(PT#)	I/O1(SP#)	I/O0(SP)
Block is protected, and device is solid-protected	x	0	0	1
Block is protected, and device is not solid-protected	x	0	1	0
Block is un-protected, and device is solid-protected	x	1	0	1
Block is un-protected, and device is not solid-protected	x	1	1	0

**Note:** *SP stands for Solid-protected. Once the SP bit sets as 1, the rest of the protection bits (BPx bits, Invert bit, Complementary bit) cannot be changed during the current power cycle.*

**Table 6-1. Address Cycle Definition of Block (1G)**

Address Cycle	I/O7	I/O6	I/O5	I/O4	I/O3	I/O2	I/O1	I/O0
Row address - 3rd cycle	A19	A18	L	L	L	L	L	L
Row address - 4th cycle	A27	A26	A25	A24	A23	A22	A21	A20

**Table 6-2. Address Cycle Definition of Block (2G)**

Address Cycle	I/O7	I/O6	I/O5	I/O4	I/O3	I/O2	I/O1	I/O0
Row address - 3rd cycle	A19	A18	L	L	L	L	L	L
Row address - 4th cycle	A27	A26	A25	A24	A23	A22	A21	A20
Row address - 5th cycle	L	L	L	L	L	L	L	A28

**Table 6-3. Address Cycle Definition of Block (4G)**

Address Cycle	I/O7	I/O6	I/O5	I/O4	I/O3	I/O2	I/O1	I/O0
Row address - 3rd cycle	A20	A19	L	L	L	L	L	L
Row address - 4th cycle	A28	A27	A26	A25	A24	A23	A22	A21
Row address - 5th cycle	L	L	L	L	L	L	L	A29

**Figure 21. AC Waveforms for Block Protection Status Read**

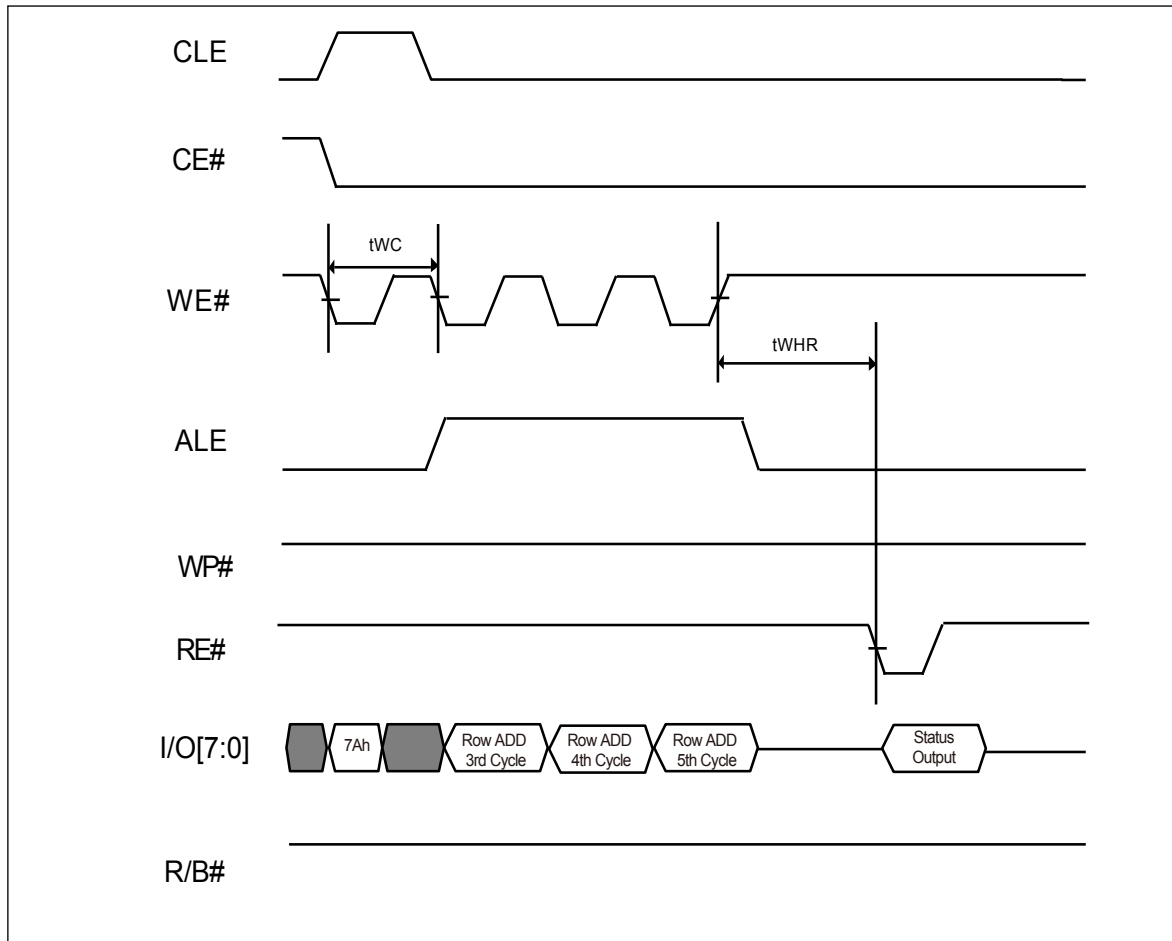

*Note: Block address cycles are two for 1Gb*



## 6-12. Reset

The reset command FFh resets the read/program/erase operation and clear the status register to be E0h (when WP# is high). The reset command during the program/erase operation will result in the content of the selected locations(perform programming/erasing) might be partially programmed/erased.

If the Flash memory has already been set to reset stage with reset command, the additional new reset command is invalid.

**Figure 22. AC waveforms for Reset Operation**

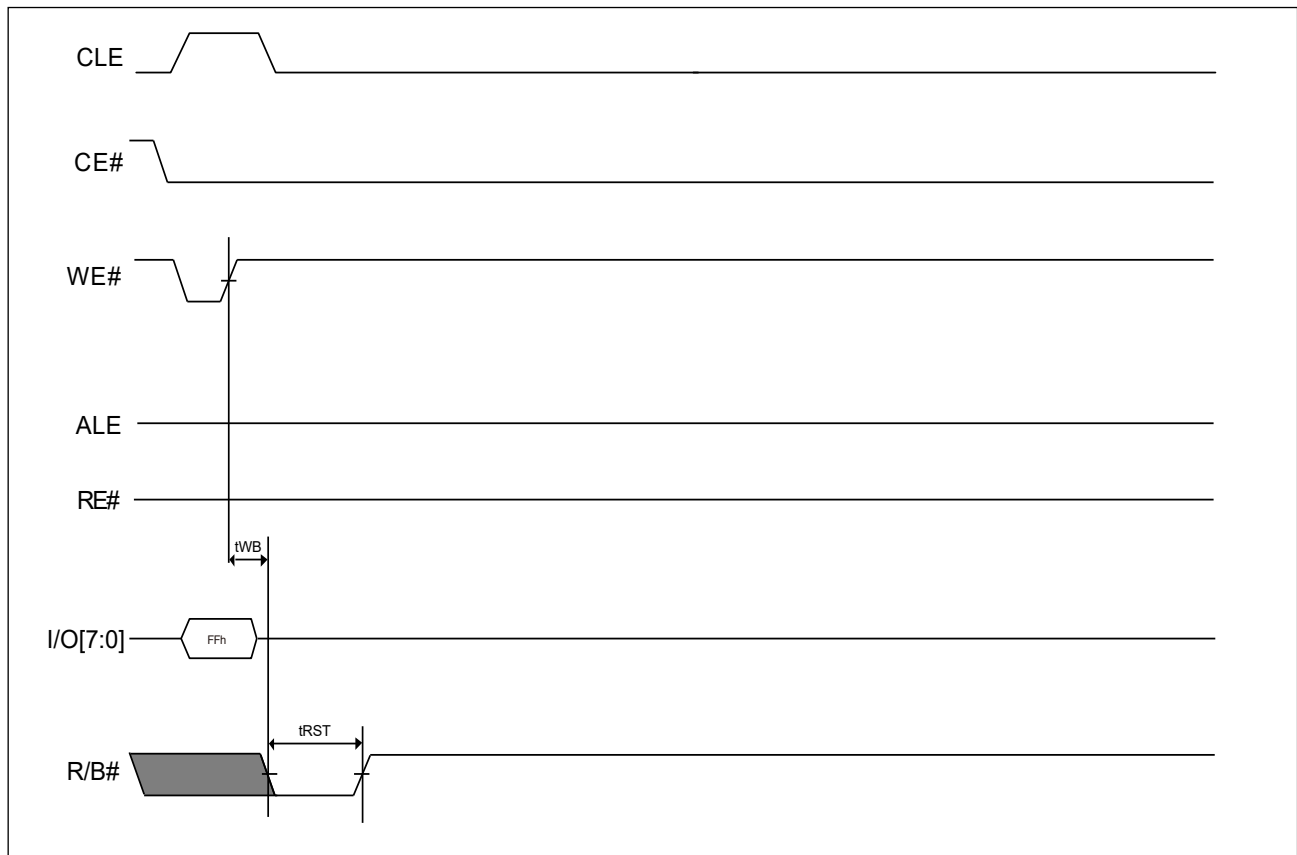

### 6-13. Parameter Page Read (ONFI)

The NAND Flash device support ONFI Parameter Page Read and the parameter can be read out by sending the command of ECh and giving the address 00h. The NAND device information may refer to the table of parameter page(ONFI), there are eight copies of 256-byte data and additional redundant parameter pages.

Once sending the ECh command, the NAND device will remain in the Parameter Page Read mode until next valid command is sent.

The Random Data Out command set (05h-E0h) can be used to change the parameter location for the specific parameter data random read out.

The Status Read command (70h) can be used to check the completion with a following read command (00h) to enable the data out.

**Figure 23. AC waveforms for Parameter Page Read (ONFI) Operation**

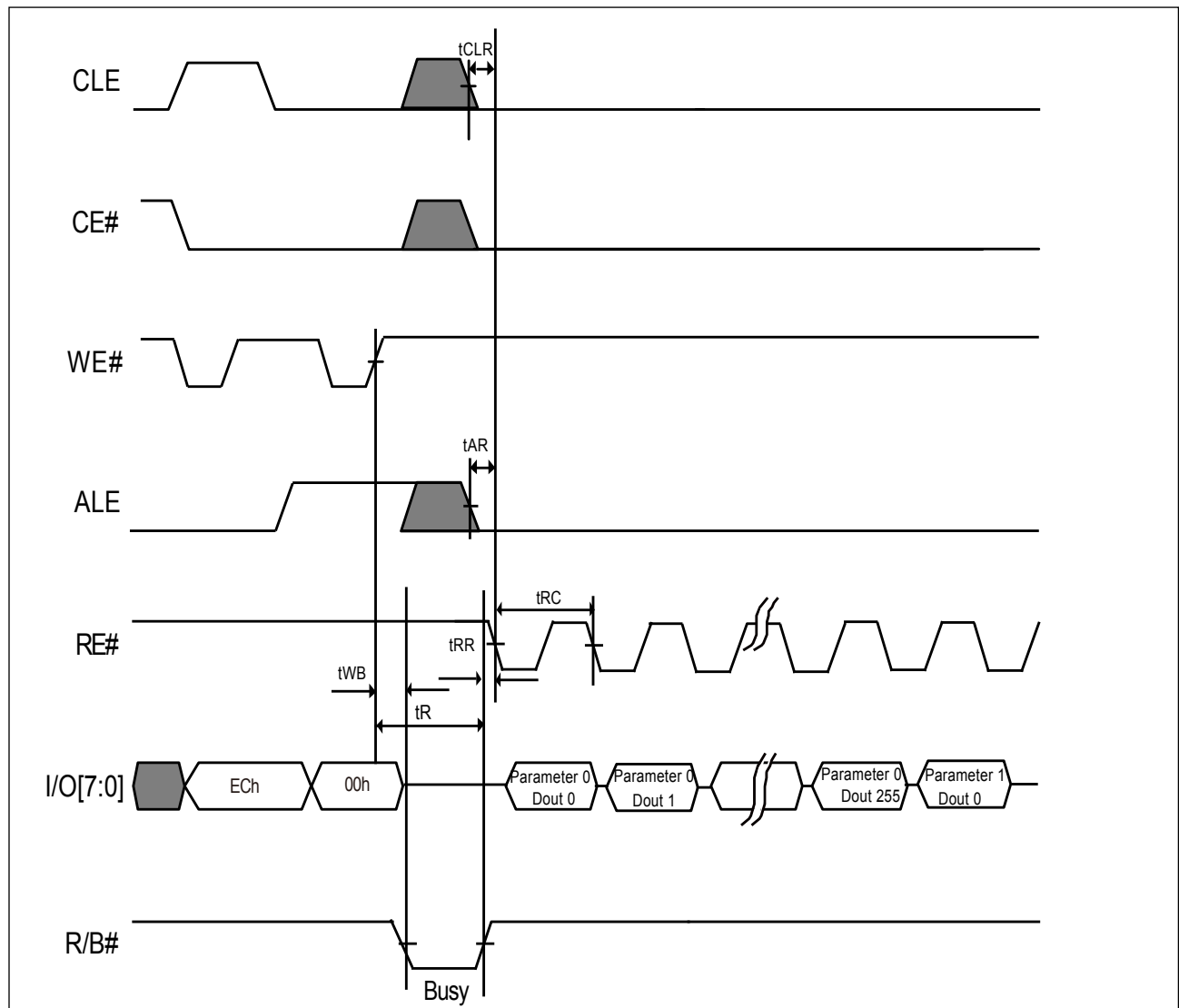

**Figure 24. AC Waveforms for Parameter Page Read (ONFI) Random Operation (For 05h-E0h)**

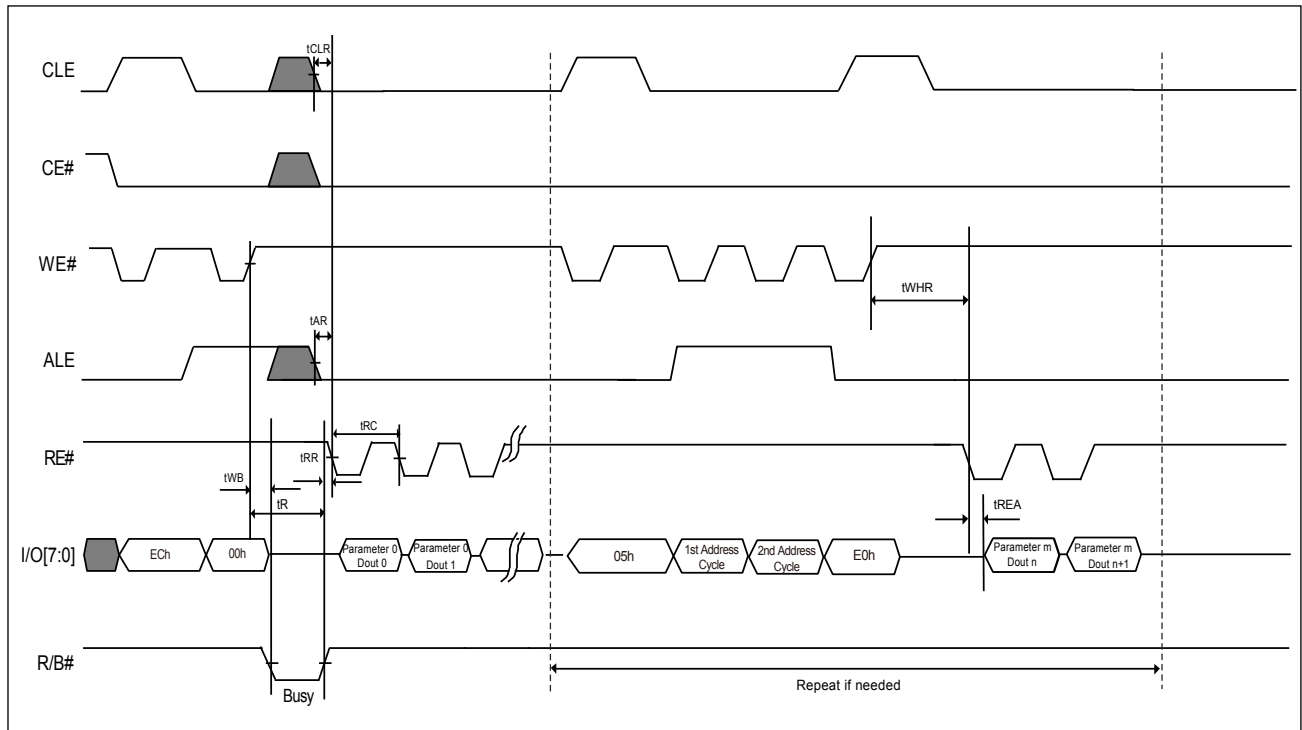

**Table 7-1. Parameter Page (ONFI) - For 1Gb**

Revision Information and Features Block			
Byte#	Description		Data
0-3	Parameter Page Signature		4Fh,4Eh,46h,49h
4-5	Revision Number		02h,00h
6-7	Features Supported		10h,00h
8-9	Optional Commands Supported		37h,00h
10-31	Reserved		00h
Manufacturer Information Block			
Byte#	Description		Data
32-43	Device Manufacturer (12 ASCII characters)		4Dh,41h,43h,52h,4Fh,4Eh,49h,58h,20h,20h,20h,20h
44-63	Device Model (20 ASCII Characters)	MX30LF1G28AD	4Dh,58h,33h,30h,4Ch,46h,31h,47h,32h,38h,41h,44h,20h,20h,20h,20h,20h,20h,20h,20h
64	JEDEC Manufacturer ID		C2h
65-66	Date Code		00h,00h
67-79	Reserved		00h
Memory Organization Block			
Byte#	Description		Data
80-83	Number of Data Bytes per Page	2048-byte	00h,08h,00h,00h
84-85	Number of Spare Bytes per Page	128-byte	80h,00h
86-89	Number of Data Bytes per Partial Page	512-byte	00h,02h,00h,00h
90-91	Number of Spare Bytes per Partial Page	32-byte	20h,00h
92-95	Number of Pages per Block		40h,00h,00h,00h
96-99	Number of Blocks per Logical Unit		00h,04h,00h,00h
100	Number of Logical Units (LUNs)		01h
101	Number of Address Cycles		22h
102	Number of Bits per Cell		01h
103-104	Bad Blocks Maximum per LUN		14h,00h
105-106	Block endurance		06h,04h
107	Guarantee Valid Blocks at Beginning of Target		08h
108-109	Block endurance for guaranteed valid blocks		00h,00h
110	Number of Programs per Page		04h
111	Partial Programming Attributes		00h
112	Number of Bits ECC Correctability		08h
113	Number of Interleaved Address Bits		00h
114	Interleaved Operation Attributes		00h
115-127	Reserved		00h

Electrical Parameters Block		
Byte#	Description	Data
128	I/O Pin Capacitance	0Ah
129-130	Timing Mode Support	3Fh,00h
131-132	Program Cache Timing Mode Support	3Fh,00h
133-134	tPROG Maximum Page Program Time (uS)	700us BCh,02h
135-136	tBERS(tERASE) Maximum Block Erase Time (uS)	6000us 70h,17h
137-138	tR Maximum Page Read Time (uS)	25us 19h,00h
139-140	tCCS Minimum Change Column Setup Time (ns)	60ns 3Ch,00h
141-163	Reserved	00h
Vendor Blocks		
Byte#	Description	Data
164-165	Vendor Specific Revision Number	00h,00h
166	Reserved	00h
167	Reliability enhancement function 2-7 Reserved(0) 1 1= Randomizer support, 0= Not support 0 1= Special read for data recovery support, 0= Not support	03h
168	Reserved	00h
169	Number of special read for data recovery (N)	05h
170-253	Vendor Specific	00h
254-255	Integrity CRC	Set at Test ( <b>Note</b> )
Redundant Parameter Pages		
Byte#	Description	Data
256-2047	Value of Bytes 0-255, total 7 copies	Same as 0-255 Byte

**Note:**

The Integrity CRC (Cycling Redundancy Check) field is used to verify that the contents of the parameters page were transferred correctly to the host. Please refer to ONFI 1.0 specifications for details.

The CRC shall be calculated using the following 16-bit generator polynomial:

$$G(X) = X_{16} + X_{15} + X_2 + 1$$

There are at least eight copies of 256-byte data and additional redundant parameter pages.

The host needs to find the parameter page of next copy if the CRC is not correct at current copy of parameter page. This procedure should be continue until the host get the correct CRC of the parameter page. The host may use bit-wise majority way to recover the content of parameter page from the copy of parameter page.

**Table 7-2. Parameter Page (ONFI) - For 2Gb**

Revision Information and Features Block			
Byte#	Description		Data
0-3	Parameter Page Signature		4Fh,4Eh,46h,49h
4-5	Revision Number		02h,00h
6-7	Features Supported		18h,00h
8-9	Optional Commands Supported		3Fh,00h
10-31	Reserved		00h
Manufacturer Information Block			
Byte#	Description		Data
32-43	Device Manufacturer (12 ASCII characters)		4Dh,41h,43h,52h,4Fh,4Eh,49h,58h,20h,20h,20h,20h
44-63	Device Model (20 ASCII Characters)	MX30LF2G28AD	4Dh,58h,33h,30h,4Ch,46h,32h,47h,32h,38h,41h,44h,20h,20h,20h,20h,20h,20h,20h,20h
64	JEDEC Manufacturer ID		C2h
65-66	Date Code		00h,00h
67-79	Reserved		00h
Memory Organization Block			
Byte#	Description		Data
80-83	Number of Data Bytes per Page	2048-byte	00h,08h,00h,00h
84-85	Number of Spare Bytes per Page	128-byte	80h,00h
86-89	Number of Data Bytes per Partial Page	512-byte	00h,02h,00h,00h
90-91	Number of Spare Bytes per Partial Page	32-byte	20h,00h
92-95	Number of Pages per Block		40h,00h,00h,00h
96-99	Number of Blocks per Logical Unit		00h,08h,00h,00h
100	Number of Logical Units (LUNs)		01h
101	Number of Address Cycles		23h
102	Number of Bits per Cell		01h
103-104	Bad Blocks Maximum per LUN		28h,00h
105-106	Block endurance		06h,04h
107	Guarantee Valid Blocks at Beginning of Target		08h
108-109	Block endurance for guaranteed valid blocks		00h,00h
110	Number of Programs per Page		04h
111	Partial Programming Attributes		00h
112	Number of Bits ECC Correctability		08h
113	Number of Interleaved Address Bits		01h
114	Interleaved Operation Attributes		0Eh
115-127	Reserved		00h

Electrical Parameters Block		
Byte#	Description	Data
128	I/O Pin Capacitance	0Ah
129-130	Timing Mode Support	3Fh,00h
131-132	Program Cache Timing Mode Support	3Fh,00h
133-134	tPROG Maximum Page Program Time (uS)	700us BCh,02h
135-136	tBERS(tERASE) Maximum Block Erase Time (uS)	6000us 70h,17h
137-138	tR Maximum Page Read Time (uS)	25us 19h,00h
139-140	tCCS Minimum Change Column Setup Time (ns)	60ns 3Ch,00h
141-163	Reserved	00h
Vendor Blocks		
Byte#	Description	Data
164-165	Vendor Specific Revision Number	00h,00h
166	Reserved	00h
167	Reliability enhancement function 2-7 Reserved(0) 1 1= Randomizer support, 0= Not support 0 1= Special read for data recovery support, 0= Not support	03h
168	Reserved	00h
169	Number of special read for data recovery (N)	05h
170-253	Vendor Specific	00h
254-255	Integrity CRC	Set at Test ( <b>Note</b> )
Redundant Parameter Pages		
Byte#	Description	Data
256-2047	Value of Bytes 0-255, total 7 copies	Same as 0-255 Byte

**Note:**

The Integrity CRC (Cycling Redundancy Check) field is used to verify that the contents of the parameters page were transferred correctly to the host. Please refer to ONFI 1.0 specifications for details.

The CRC shall be calculated using the following 16-bit generator polynomial:

$$G(X) = X_{16} + X_{15} + X_2 + 1$$

There are at least eight copies of 256-byte data and additional redundant parameter pages.

The host needs to find the parameter page of next copy if the CRC is not correct at current copy of parameter page. This procedure should be continue until the host get the correct CRC of the parameter page. The host may use bit-wise majority way to recover the content of parameter page from the copy of parameter page.

**Table 7-3. Parameter Page (ONFI) - For 4Gb**

Revision Information and Features Block			
Byte#	Description		Data
0-3	Parameter Page Signature		4Fh,4Eh,46h,49h
4-5	Revision Number		02h,00h
6-7	Features Supported		18h,00h
8-9	Optional Commands Supported		3Fh,00h
10-31	Reserved		00h
Manufacturer Information Block			
Byte#	Description		Data
32-43	Device Manufacturer (12 ASCII characters)		4Dh,41h,43h,52h,4Fh,4Eh,49h,58h,20h,20h,20h,20h
44-63	Device Model (20 ASCII Characters)	MX30LF4G28AD	4Dh,58h,33h,30h,4Ch,46h,34h,47h,32h,38h,41h,44h,20h,20h,20h,20h,20h,20h,20h,20h
64	JEDEC Manufacturer ID		C2h
65-66	Date Code		00h,00h
67-79	Reserved		00h
Memory Organization Block			
Byte#	Description		Data
80-83	Number of Data Bytes per Page		4096-byte 00h,10h,00h,00h
84-85	Number of Spare Bytes per Page		256-byte 00h,01h
86-89	Number of Data Bytes per Partial Page		1024-byte 00h,04h,00h,00h
90-91	Number of Spare Bytes per Partial Page		64-byte 40h,00h
92-95	Number of Pages per Block		40h,00h,00h,00h
96-99	Number of Blocks per Logical Unit		00h,08h,00h,00h
100	Number of Logical Units (LUNs)		01h
101	Number of Address Cycles		23h
102	Number of Bits per Cell		01h
103-104	Bad Blocks Maximum per LUN		28h,00h
105-106	Block endurance		06h,04h
107	Guarantee Valid Blocks at Beginning of Target		08h
108-109	Block endurance for guaranteed valid blocks		00h,00h
110	Number of Programs per Page		04h
111	Partial Programming Attributes		00h
112	Number of Bits ECC Correctability		08h
113	Number of Interleaved Address Bits		01h
114	Interleaved Operation Attributes		0Eh
115-127	Reserved		00h



Electrical Parameters Block			
Byte#	Description	Data	
128	I/O Pin Capacitance	0Ah	
129-130	Timing Mode Support	3Fh,00h	
131-132	Program Cache Timing Mode Support	3Fh,00h	
133-134	tPROG Maximum Page Program Time (uS)	700us	BCh,02h
135-136	tBERS(tERASE) Maximum Block Erase Time (uS)	6000us	70h,17h
137-138	tR Maximum Page Read Time (uS)	25us	19h,00h
139-140	tCCS Minimum Change Column Setup Time (ns)	60ns	3Ch,00h
141-163	Reserved	00h	
Vendor Blocks			
Byte#	Description	Data	
164-165	Vendor Specific Revision Number	00h,00h	
166	Reserved	00h	
167	Reliability enhancement function 2-7 Reserved(0) 1 1= Randomizer support, 0= Not support 0 1= Special read for data recovery support, 0= Not support	03h	
168	Reserved	00h	
169	Number of special read for data recovery (N)	05h	
170-253	Vendor Specific	00h	
254-255	Integrity CRC	Set at Test ( <b>Note</b> )	
Redundant Parameter Pages			
Byte#	Description	Data	
256-2047	Value of Bytes 0-255, total 7 copies	Same as 0-255 Byte	
2048+	Additional Redundant Parameter Pages		

**Note:**

The Integrity CRC (Cycling Redundancy Check) field is used to verify that the contents of the parameters page were transferred correctly to the host. Please refer to ONFI 1.0 specifications for details.

The CRC shall be calculated using the following 16-bit generator polynomial:

$$G(X) = X_{16} + X_{15} + X_2 + 1$$

There are at least eight copies of 256-byte data and additional redundant parameter pages.

The host needs to find the parameter page of next copy if the CRC is not correct at current copy of parameter page. This procedure should be continue until the host get the correct CRC of the parameter page. The host may use bit-wise majority way to recover the content of parameter page from the copy of parameter page.

## 6-14. Unique ID Read (ONFI) with PUF-like Code Structure<sup>Note</sup>

The MX30LFxG28AD unique ID adopts Macronix PUF-like code structure, which is truly random and the numbers of "0" bit almost equal to numbers of "1" bit. The unique ID is 32-byte and with 16 copies for back-up purpose. After writing the Unique ID read command (EDh) and following the one address byte (00h), the host may read out the unique ID data. The host need to XOR the 1st 16-byte unique data and the 2nd 16-byte complement data to get the result, if the result is FFh, the unique ID data is correct; otherwise, host need to repeat the XOR with the next copy of Unique ID data.

Once sending the EDh command, the NAND device will remain in the Unique ID read mode until next valid command is sent.

To change the data output location, it is recommended to use the Random Data Out command set (05h-E0h).

The Status Read command (70h) can be used to check the completion. To continue the read operation, a following read command (00h) to re-enable the data out is necessary.

**Note:** PUF stands for Physical Unclonable Function

**Figure 25. AC waveforms for Unique ID Read Operation**

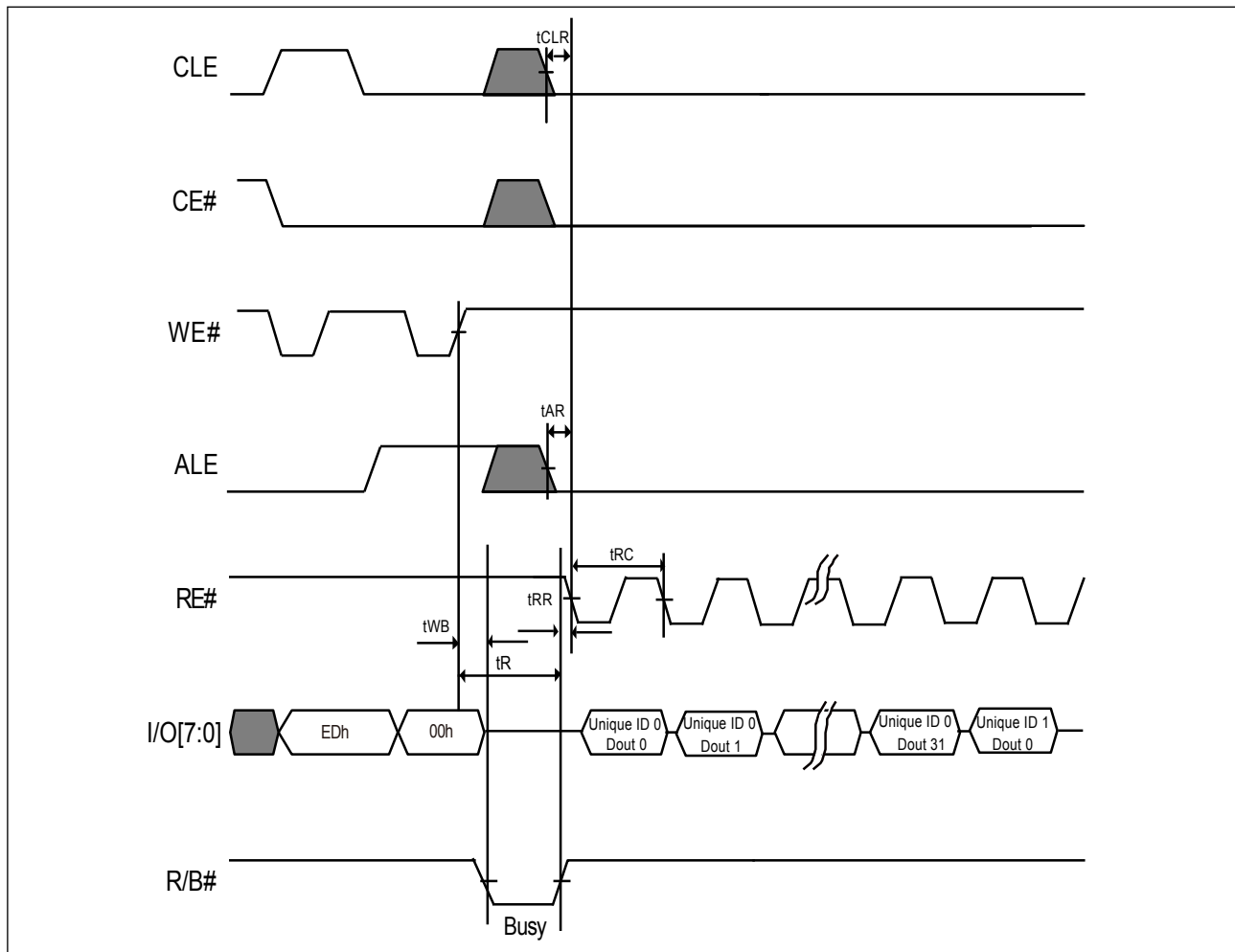
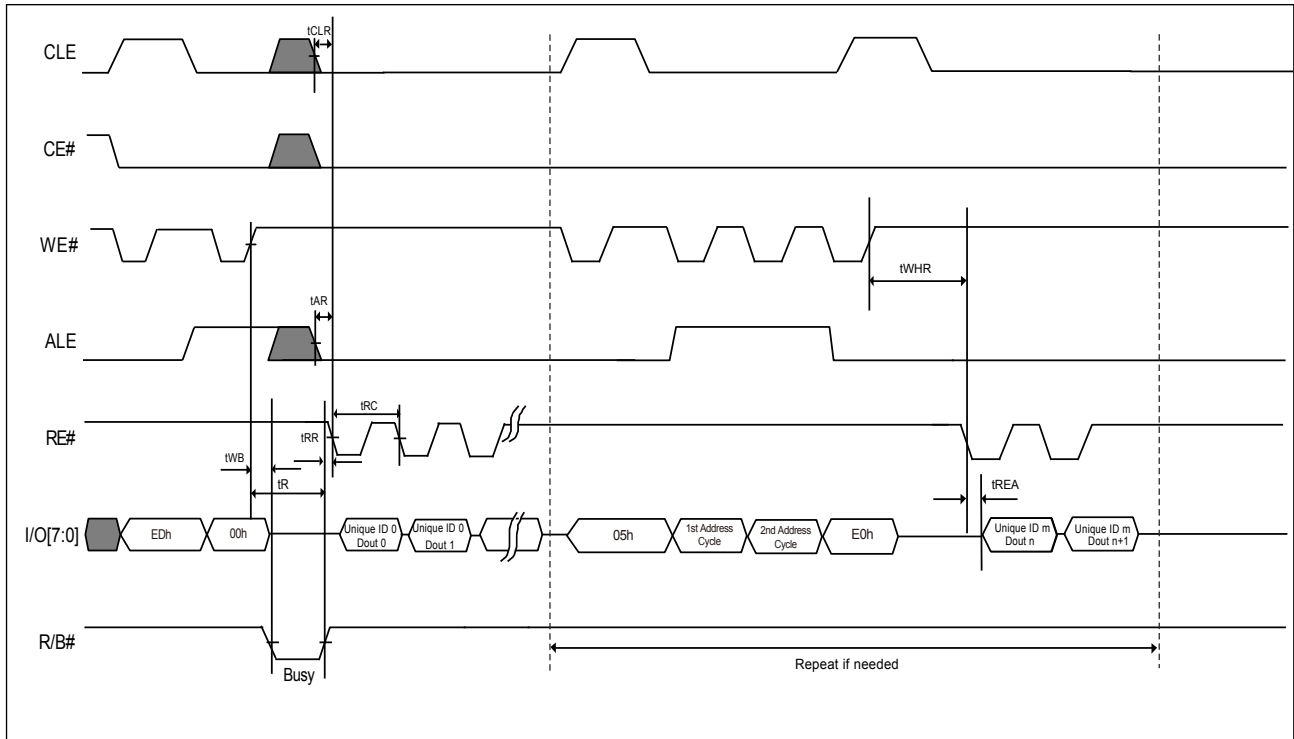

Figure 26. AC waveforms for Unique ID Read Operation (For 05h-E0h)



## 6-15. Feature Set Operation (ONFI)

The Feature Set operation is to change the default power-on feature sets by using the Set Feature and Get Feature command and writing the specific parameter data (P1-P4) on the specific feature addresses. The NAND device may remain the current feature set until next power cycle for those the feature set data is volatile. However, the reset command (FFh) can not reset the current feature set. For those Feature Bits of V2 type (Volatile Register with OTP Fuse Default Value) (e.g. I/O Drive strength, RANDOPT, RANDEN, etc.) the default value of these volatile feature bits can be changed once by a particular flowchart. To change the default value of “RANDOPT” and “RANDEN” may refer to the Flowchart of RANDEN and RANDOPT Bits Program Operation. As for the change of default value of I/O strength, may refer to the Flowchart of I/O Drive Strength Bits Program Operation. After power on, the value can be changes again but will go back to default value after power cycle.

**Table 8-1. Definition of Feature Address**

Feature Address	Description
00h, 02h-7Fh, 81h-88h, 8Ah-8Fh, 91h-9Fh, A1h-AFh, B1h-FFh	Reserved
01h	Timing Mode
80h	Programmable I/O Drive Strength
89h	Special Read for Data Recovery Operation
90h	Array Operation Mode
A0h	Block Protection Operation
B0h	Configuration

**Table 8-2. Sub-Feature Parameter Table of Feature Address - 01h (Timing Mode)**

Sub Feature Parameter	Definition	I/O7	I/O6	I/O5	I/O4	I/O3	I/O2	I/O1	I/O0	Values	Notes
P1	Timing Mode	Mode=0 (Default)		Reserved (0)			0	0	0	00h	1
		Mode 1		Reserved (0)			0	0	1	01h	
		Mode 2		Reserved (0)			0	1	0	02h	
		Mode 3		Reserved (0)			0	1	1	03h	
		Mode 4		Reserved (0)			1	0	0	04h	
		Mode 5		Reserved (0)			1	0	1	05h	
P2		Reserved (0)								00h	
P3		Reserved (0)								00h	
P4		Reserved (0)								00h	

**Note 1.** Please refer to ONFI standard for detail specifications on Mode 0,1,2,3,4,5.

**Table 8-3. Sub-Feature Parameter Table of Feature Address - 80h (Programmable I/O Drive Strength)**

Sub Feature Parameter	Definition	I/O7	I/O6	I/O5	I/O4	I/O3	I/O2	I/O1	I/O0	Values	Notes
P1	I/O Drive Strength	35ohm (Default)		Reserved (0)			0	0	00h		
		85ohm		Reserved (0)			0	1	01h		
P2		Reserved (0)								00h	
P3		Reserved (0)								00h	
P4		Reserved (0)								00h	

**Note:** The value of I/O Drive Strength Bits are volatile type (V2 type). The V2 type which the value is volatile type; however, the default value of these V2 volatile feature bits can be changed once by the I/O Drive Strength Bits Program Operation.

**Table 8-4. Sub-Feature Parameter Table of Feature Address - 89h (Special Read for Data Recovery Operation)**

Sub Feature Parameter	Definition		I/O7	I/O6	I/O5	I/O4	I/O3	I/O2	I/O1	I/O0	Values	Notes
P1	Special Read for Data Recovery	Disable (Default)	Reserved (0)					0	0	0	00h	1
		Special Read Mode 1	Reserved (0)					0	0	1	01h	
		Special Read Mode 2	Reserved (0)					0	1	0	02h	
		Special Read Mode 3	Reserved (0)					0	1	1	03h	
		Special Read Mode 4	Reserved (0)					1	0	0	04h	
		Special Read Mode 5	Reserved (0)					1	0	1	05h	
P2			Reserved (0)								00h	
P3			Reserved (0)								00h	
P4			Reserved (0)								00h	

**Note 1.** The value is clear to 00h at power cycle.

**Table 8-5. Sub-Feature Parameter Table of Feature Address - 90h (Array Operation Mode)**

Sub Feature Parameter	Definition		I/O7	I/O6	I/O5	I/O4	I/O3	I/O2	I/O1	I/O0	Values	Notes
P1	Array Operation Mode	Normal	Reserved (0)					0	0	0000 0000b	1	
		OTP Operation	Reserved (0)				0	0	1	0000 0001b		
		OTP Protection	Reserved (0)				0	1	1	0000 0011b		
P2			Reserved (0)								0000 0000b	
P3			Reserved (0)								0000 0000b	
P4			Reserved (0)								0000 0000b	

**Note 1.** The value is clear to 00h at power cycle.

**Table 8-6. Sub-Feature Parameter Table of Feature Address - A0h (Block Protection Operation) (note 1)**

Sub Feature Parameter	Definition		I/O7	I/O6	I/O5	I/O4	I/O3	I/O2	I/O1	I/O0	Values	Notes
P1	Block Protection Operation	Default mode	0	0	1	1	1	0	0	0	38h	note 2
		Protection Bit Setting	0	0	BP2	BP1	BP0	Invert	Complementary	SP	note 3	note 4
P2			Reserved (0)									
P3			Reserved (0)									
P4			Reserved (0)									

**Notes:**

1. If the PT pin is not connected to high, this sub-feature address A0h command is not valid.
2. The value is returned to 38h at power cycle.
3. The value is defined in the "Table 9. Definition of Protection Bits".
4. The SP stands for Solide-Protection. Once the SP bit sets as 1, the rest of protection bits cannot be changed during the current power cycle.

**Table 8-7. Sub-Feature Parameter Table of Feature Address – B0h (Configuration)**

Sub Feature Parameter	Definition		I/O7	I/O6	I/O5	I/O4	I/O3	I/O2	I/O1	I/O0	Value	
P1	Configuration	Disable (Default)	Reserved (0)						0	0	0	00h
		Randomizer Operation							RANDOPT (Randomizer option) <sup>Note1, Note2</sup>	RANDEN (Enable Randomizer) <sup>Note1</sup>	ENPGM (Enable RANDOPT and RANDEN Program)	
P2			Reserved (0)									
P3			Reserved (0)									
P4			Reserved (0)									

**Notes:**

1. The value of RANDOPT and RANDEN Bits are volatile type (V2 type). The V2 type which the value is volatile type; however, the default value of these V2 volatile feature bits can be changed once by the flowchart of RANDEN and RANDOPT Bits Program Operation.
2. The value is defined in the "Table 10. The definition of RANDOPT bit for the randomized area per page (as grey color)".
3. The ENPGM bit is volatile bit

Figure 27. The Flowchart of I/O Drive Strength Bits Program Operation

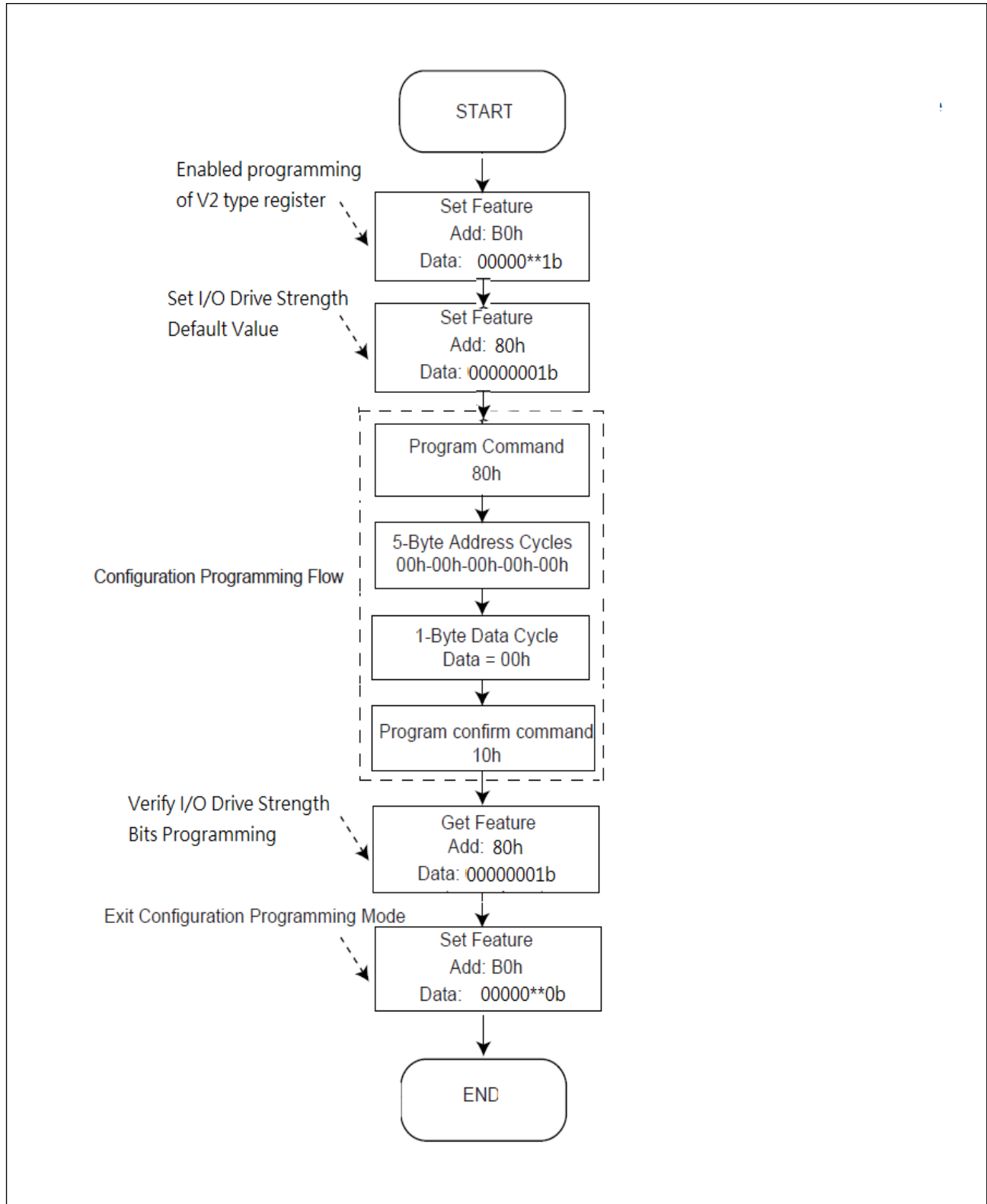

### 6-15-1. Set Feature (ONFI)

The Set Feature command is to change the power-on default feature set. After sending the Set Feature command (EFh) and following specific feature and then input the P1-P4 parameter data to change the default power-on feature set. Once sending the EFh command, the NAND device will remain in the Set Feature mode until next valid command is sent.

The Status Read command (70h) may check the completion of the Set Feature.

**Figure 28-1. AC Waveforms for Set Feature (ONFI) Operation**

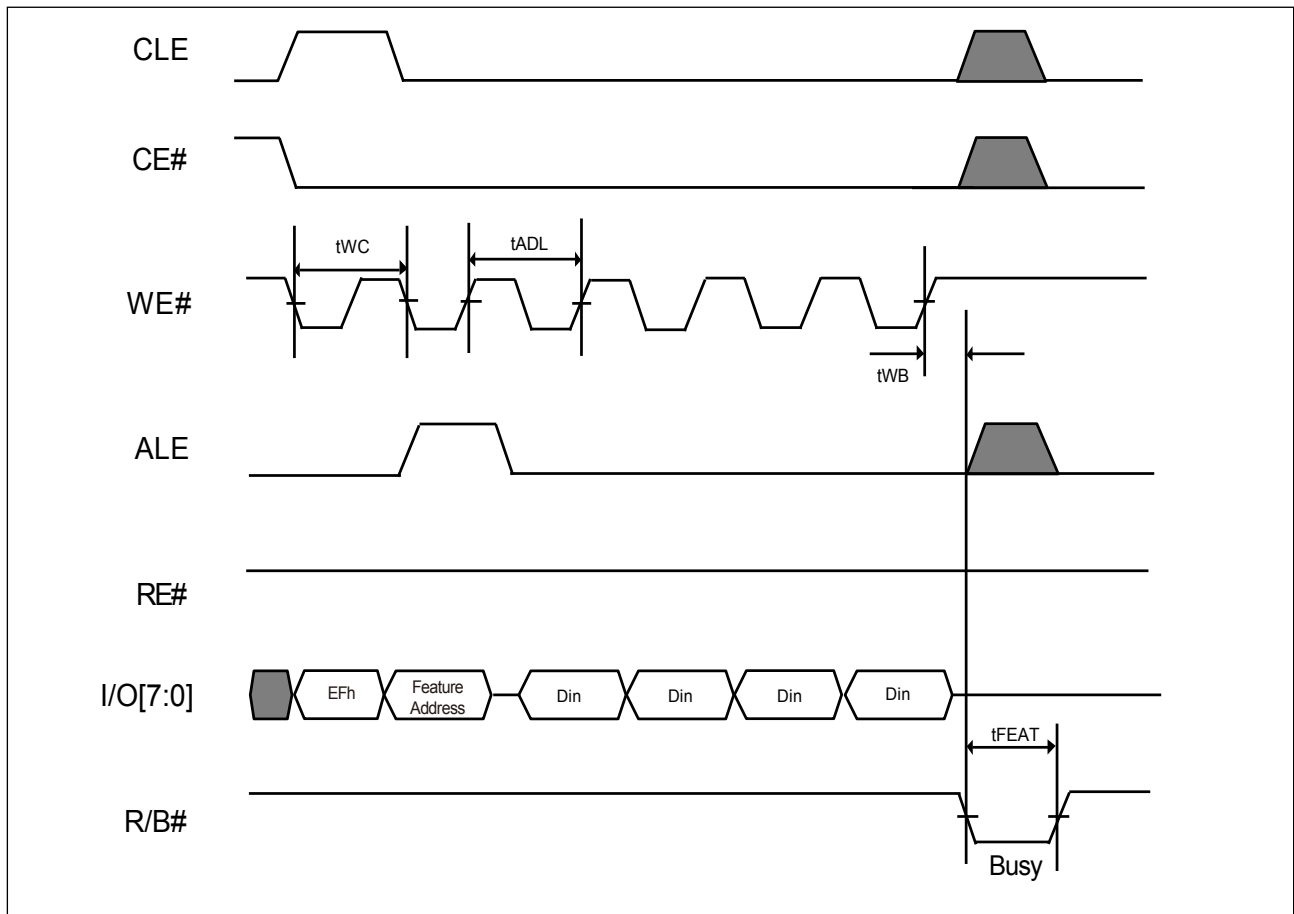



### 6-15-2. Get Feature (ONFI)

The Get Feature command is to read sub-feature parameter. After sending the Get Feature command (EEh) and following specific feature, the host may read out the P1-P4 sub- feature parameter data. Once sending the EEh command, the NAND device will remain in the Get Feature mode until next valid command is sent.

The Status Read command (70h) can be used to check the completion. To continue the read operation, a following read command (00h) to re-enable the data out is necessary.

Please refer to the following waveform of **Get Feature Operation** for details.

**Figure 28-2. AC Waveforms for Get Feature (ONFI) Operation**

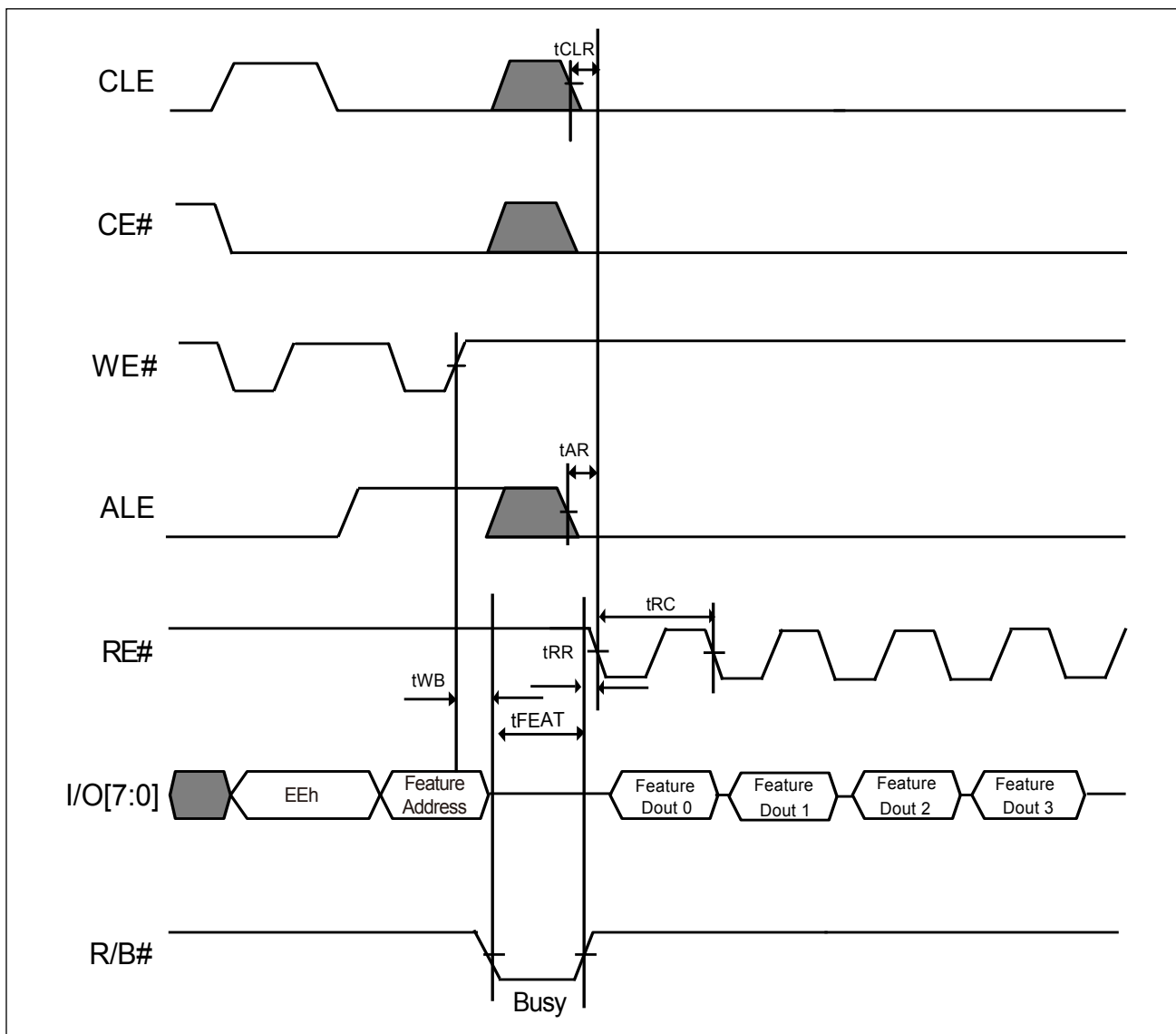

### 6-15-3. Special Read for Data Recovery

When the host ECC fails to correct the data error of NAND device, there's a special read for data recovery method which host executes the Special Read for Data Recovery operation and may recover the lost data by host ECC again. After that, it is needed to move the data to another good block.

The Special Read for Data Recovery operation is enabled by Set Feature function("Table 8-1. Definition of Feature Address" and "Table 8-4. Sub-Feature Parameter Table of Feature Address - 89h (Special Read for Data Recovery Operation)"). There are 5 modes for the user to recover the lost data. The procedure of entering and exiting the operation is shown as the figure below.

**Figure 29. Procedure of entering /exiting the Special Read for Data Recovery operation**

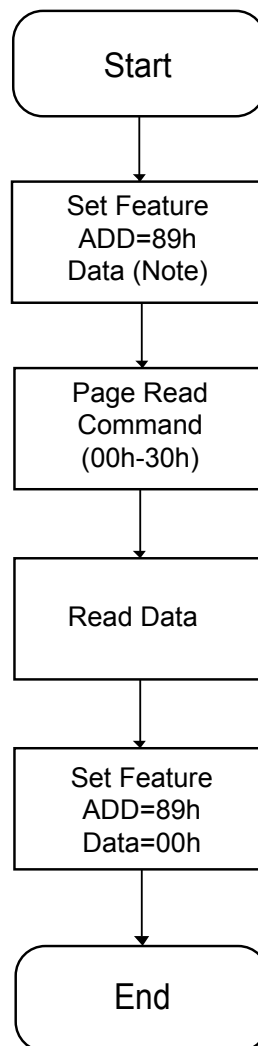

**Note:** Please refer to the "Table 8-4. Sub-Feature Parameter Table of Feature Address - 89h (Special Read for Data Recovery Operation)".

### 6-15-4. Secure OTP (One-Time-Programmable) Feature

There is an OTP area which has thirty full pages (30 x 2,176-byte) for 1Gb/2Gb and (30 x 4,352-byte) for 4Gb) guarantee to be good for system device serial number storage or other fixed code storage. The OTP area is a non-erasable and one-time-programmable area, which is default to “1” and allows whole page or partial page program to be “0”, once the OTP protection mode is set, the OTP area becomes read-only and cannot be programmed again. The OTP area is scrambled if randomizer function is enabled.

The OTP operation is operated by the Set Feature/ Get Feature operation to access the OTP operation mode and OTP protection mode.

To check the NAND device is ready or busy in the OTP operation mode, either checking the R/B# or writing the Status Read command (70h) may collect the status.

To exit the OTP operation or protect mode, it can be done by writing 00h to P1 at feature address 90h.

#### OTP Read/Program Operation

To enter the OTP operation mode, it is by using the Set Feature command (EFh) and followed by the feature address (90h) and then input the 01h to P1 and 00h to P2-P4 of sub-Feature Parameter data( please refer to the sub-Feature Parameter table). After enter the OTP operation mode, the normal Read command (00h-30h) or Page program( 80h-10h) command can be used to read the OTP area or program it. The address of OTP is located on the 02h-1Fh of page address.

Besides the normal Read command, the Random Data Output command (05h-E0h) can be used for read OTP data. However, the Cache Read command is not supported in the OTP area.

Besides the normal page program command, the Random Data Input command (85h) allows multi-data load in non-sequential address. After data load is completed, a program confirm command (10h) is issued to start the page program operation. The number of partial-page OTP program is 8 per each OTP page.

**Figure 30. AC Waveforms for OTP Data Read**

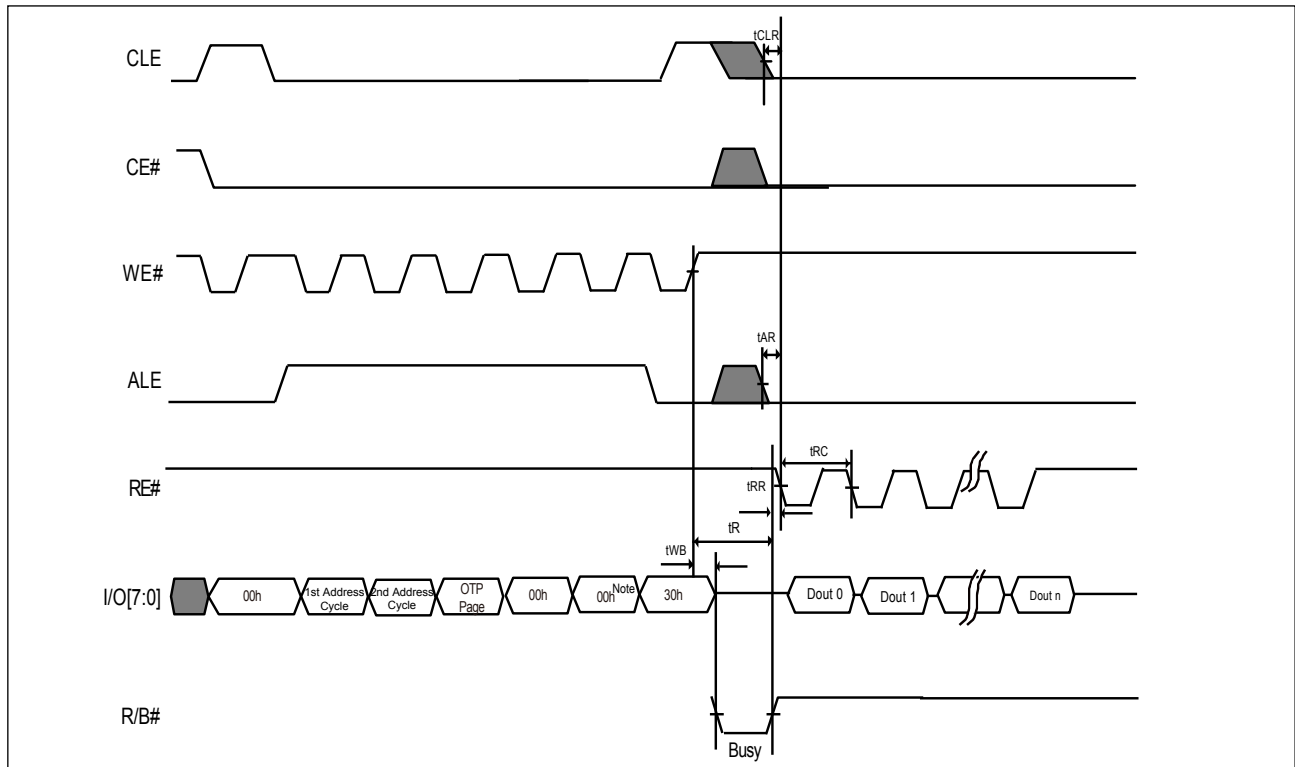

**Note:** Address cycle of 1Gb is four; therefore, the last address cycle of "00h" is for 2Gb/4Gb.

Figure 31. AC Waveforms for OTP Data Read with Random Data Output

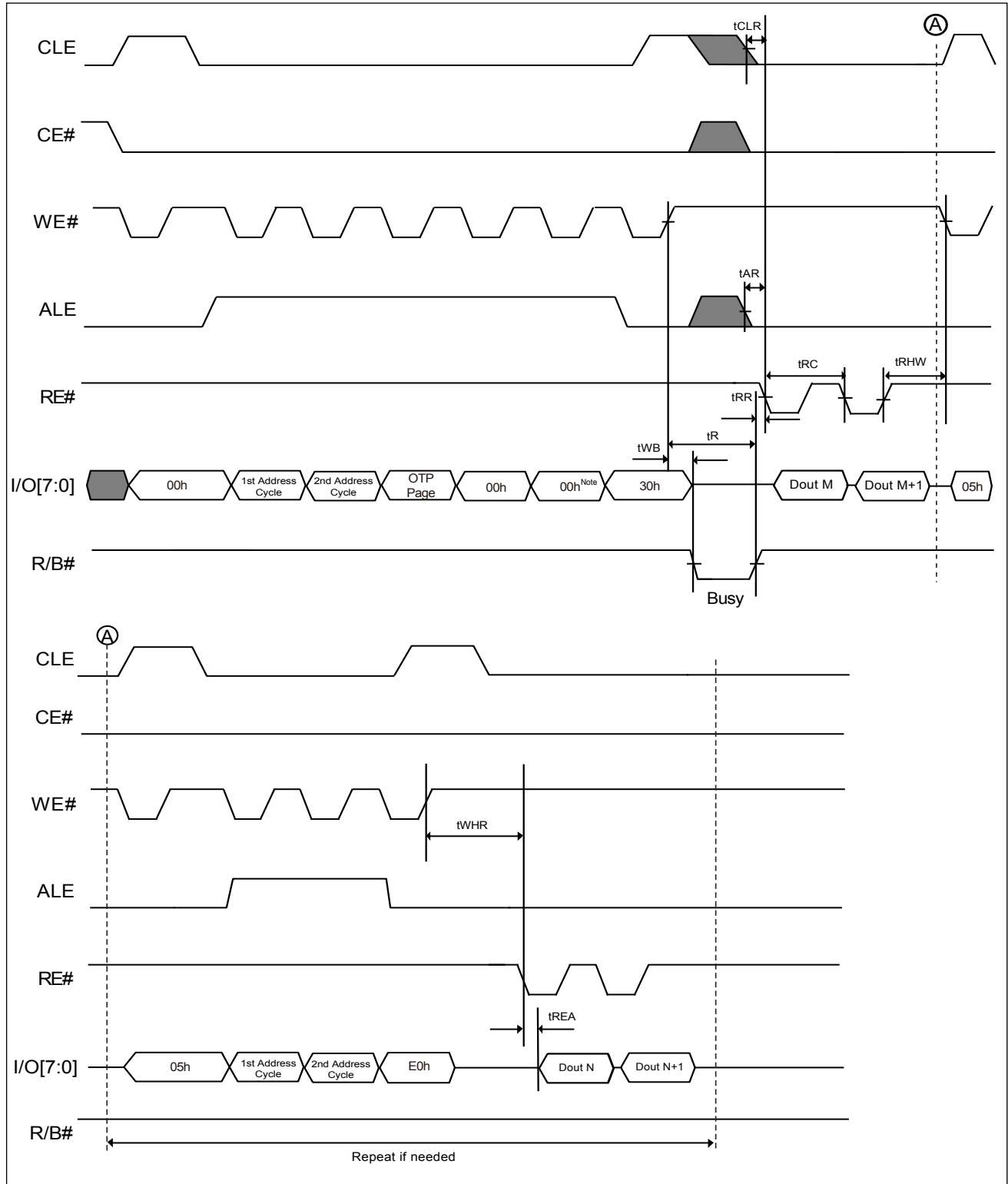

**Note:** Address cycle of 1Gb is four; therefore, the last address cycle of "00h" is for 2Gb/4Gb.

Figure 32-1. AC Waveforms for OTP Data Program (1Gb)

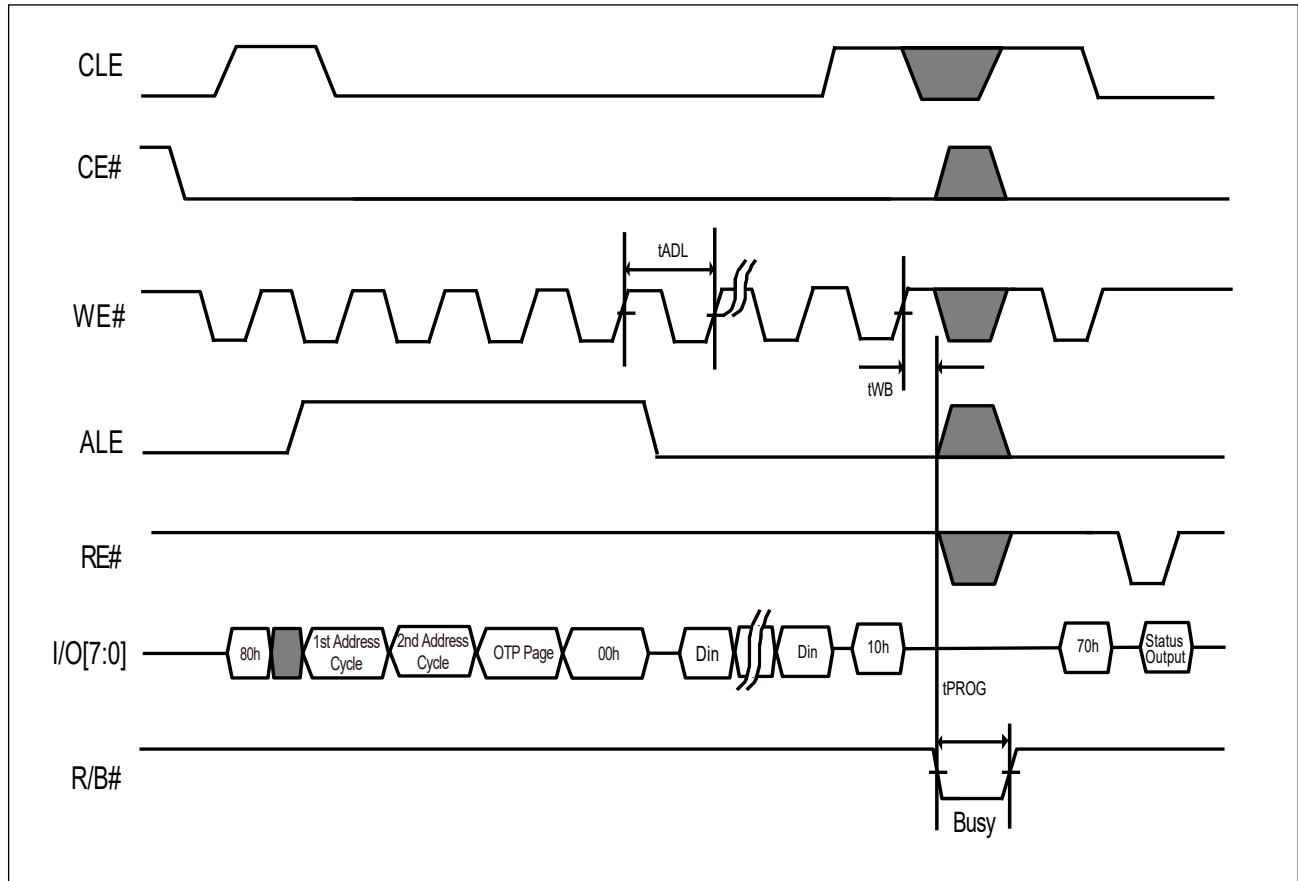

Figure 32-2. AC Waveforms for OTP Data Program (2Gb/4Gb)

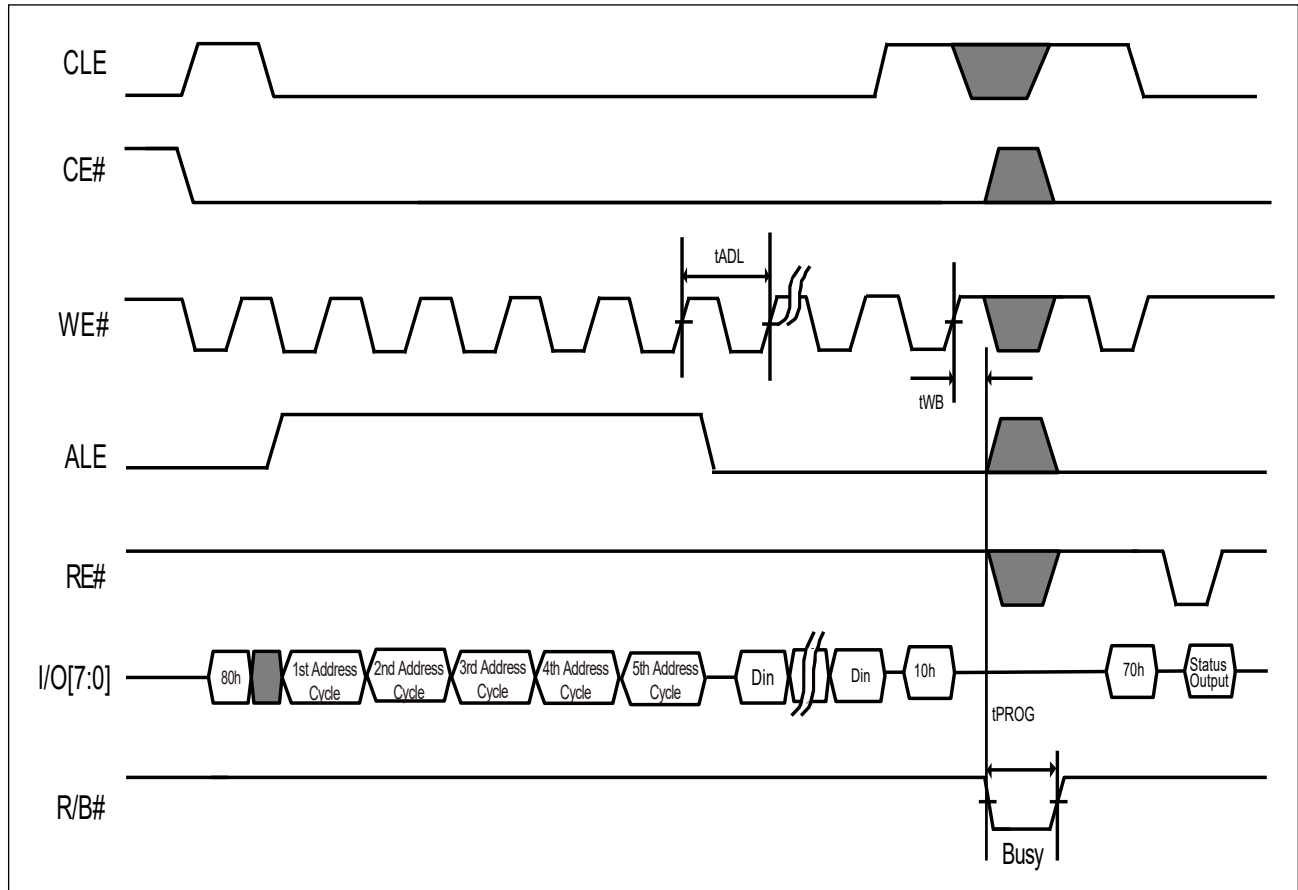
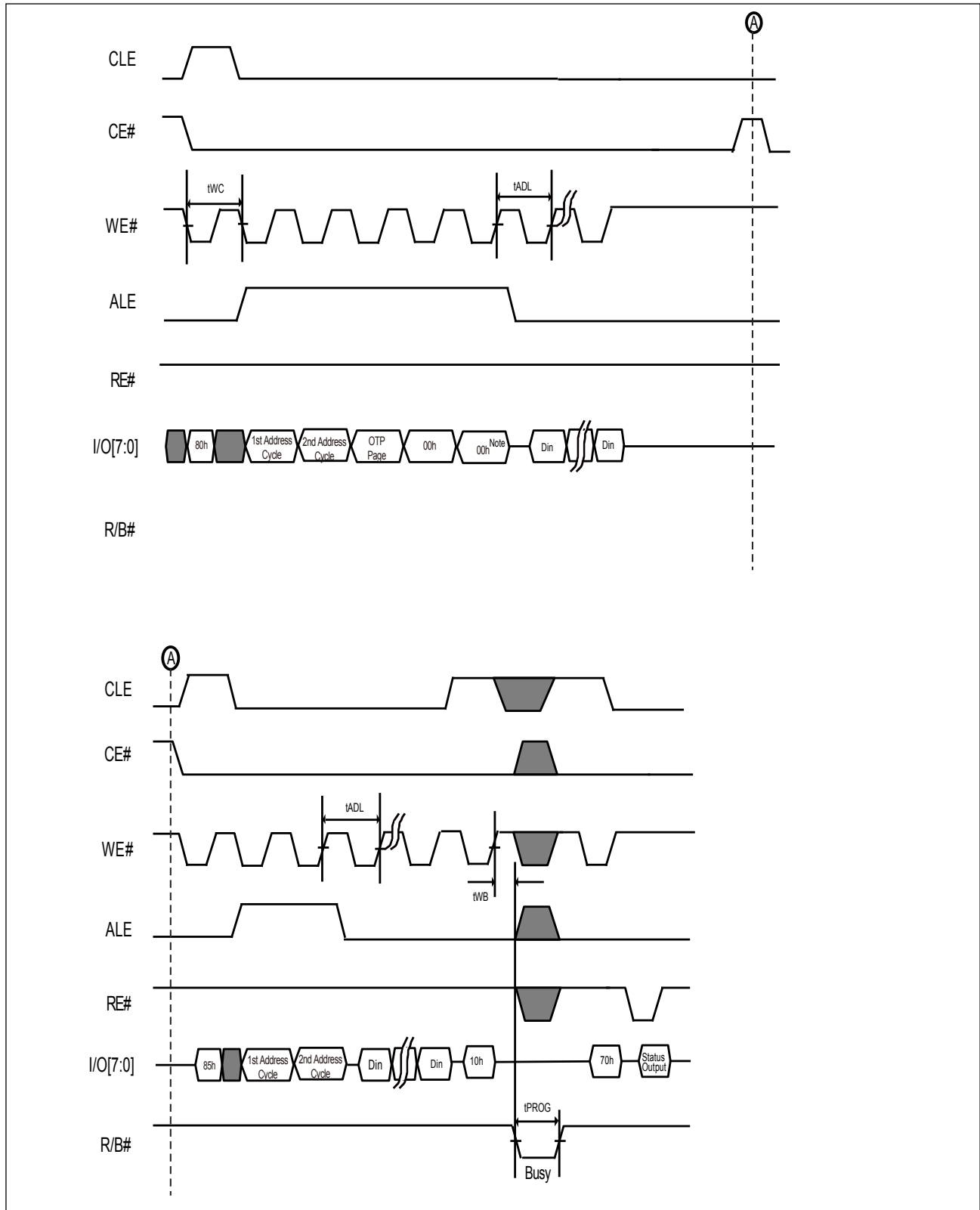

Figure 33. AC Waveforms for OTP Data Program with Random Data Input



**Note:** Address cycle of 1Gb is four; therefore, the last address cycle of "00h" is for 2Gb/4Gb.

### OTP Protection Operation

To prevent the further OTP data to be changed, the OTP protection mode operation is necessary. To enter the OTP protection mode, it can be done by using the Set Feature command (EFh) and followed by the feature address (90h) and then input the 03h to P1 and 00h to P2-P4 of sub-Feature Parameter data (please refer to the sub-Feature Parameter table). And then the normal page program command (80h-10h) with the address 00h before the 10h command is required.

The OTP Protection mode is operated by the whole OTP area instead of individual OTP page. Once the OTP protection mode is set, the OTP area cannot be programmed or unprotected again.

**Figure 34. AC Waveforms for OTP Protection Operation**

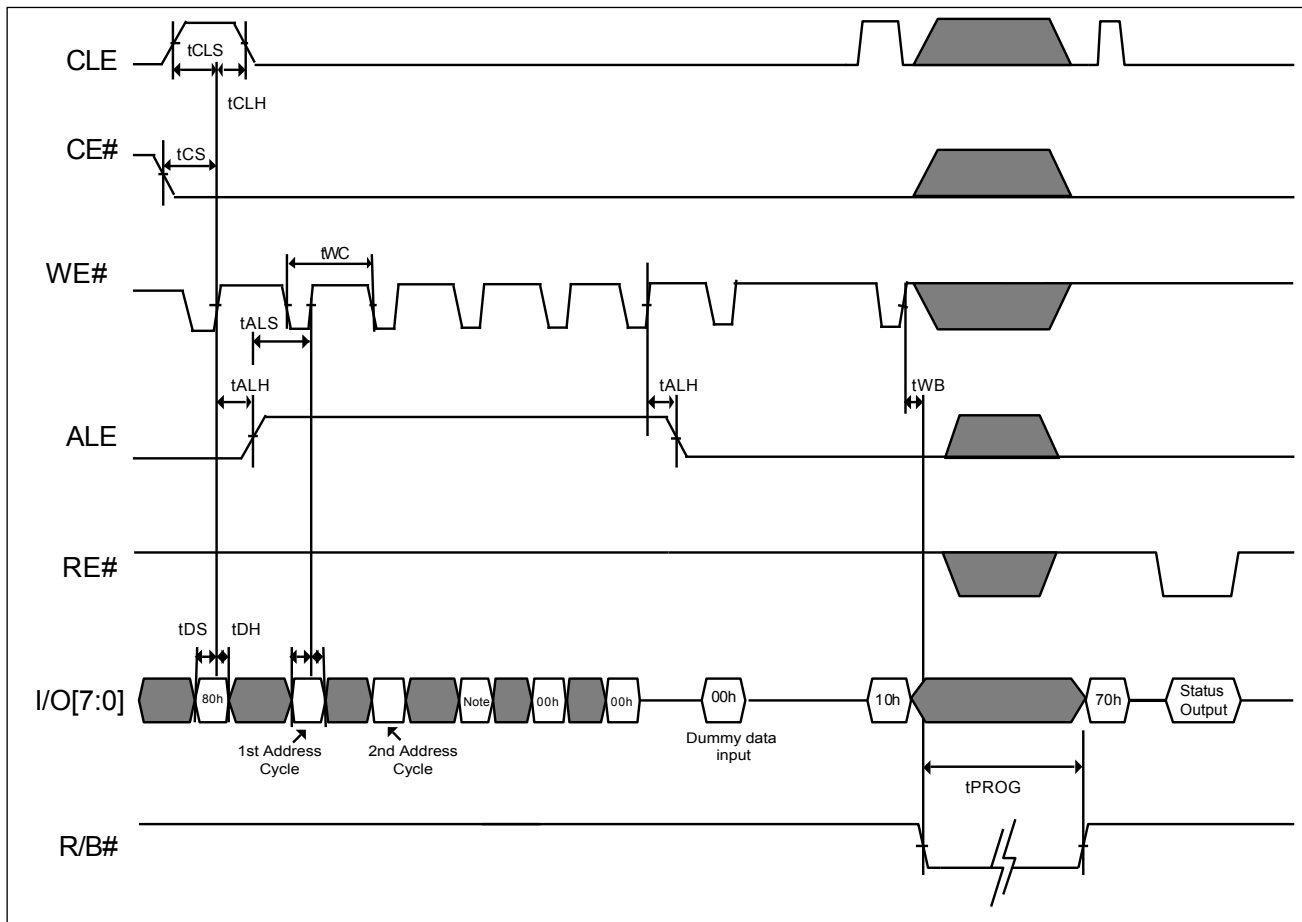

**Note:** This address cycle can be any value since the OTP protection protects the entire OTP area instead of individual OTP page.



## 6-15-5. Block Protection

The block protect operation can protect the whole chip or selected blocks from erasing or programming. Through the PT pin at power-on stage, it decides the block protection operation is enabled or disabled. At power-on, if the PT pin is connected to high, the block protection operation is enabled, all the blocks are default to be protected from programming/erasing even the WP# is disabled. If the PT pin is low, block protection operation is disabled. Please refer to "Figure 35. PT Pin and Block Protection Mode Operation".

When program or erase attempt at a protected block is happened, the R/B# keeps low for the time of tPBSY. User may get the block protection status by sending Block Protection Status Read command (7Ah) if the protection was set by PT pin. The Status Register SR [7] of Status Read command (70h) is only report for the WP# signal.

There are Temporary Protection/un-Protection and Solid Protection features as below description.

### Temporary Protection/un-Protection

At power-on, if the PT pin is connected to high, all the blocks are default to be protected for the BPx protection bits are all "1". The Set feature command with feature address A0h followed by the destined protection bits data is necessary to un-protect those selected blocks before those selected blocks to be updated. The WP# pin needs to connect to high before writing the Set Feature command for the block protection operation. After the selected blocks are un-protected, those un-protected blocks can be protected again by Block Protection procedure if required.

### Solid Protection

The "solid-protection" feature can be set by writing the Set Feature command with address A0h and the "SP" solid-protection bit as "1", after that, the selected block is solid-protected and cannot be up-protected until next power cycle.

**Table 9. Definition of Protection Bits**

BP2	BP1	BP0	Invert	Complementary	Protection Area
0	0	0	x	x	all unlocked
0	0	1	0	0	upper 1/64 locked
0	1	0	0	0	upper 1/32 locked
0	1	1	0	0	upper 1/16 locked
1	0	0	0	0	upper 1/8 locked
1	0	1	0	0	upper 1/4 locked
1	1	0	0	0	upper 1/2 locked
1	1	1	x	x	all locked (default)
0	0	1	1	0	lower 1/64 locked
0	1	0	1	0	lower 1/32 locked
0	1	1	1	0	lower 1/16 locked
1	0	0	1	0	lower 1/8 locked
1	0	1	1	0	lower 1/4 locked
1	1	0	1	0	lower 1/2 locked
0	0	1	0	1	lower 63/64 locked
0	1	0	0	1	lower 31/32 locked
0	1	1	0	1	lower 15/16 locked
1	0	0	0	1	lower 7/8 locked
1	0	1	0	1	lower 3/4 locked
1	1	0	0	1	block 0
0	0	1	1	1	upper 63/64 locked
0	1	0	1	1	upper 31/32 locked
0	1	1	1	1	upper 15/16 locked
1	0	0	1	1	upper 7/8 locked
1	0	1	1	1	upper 3/4 locked
1	1	0	1	1	block0

Figure 35. PT Pin and Block Protection Mode Operation

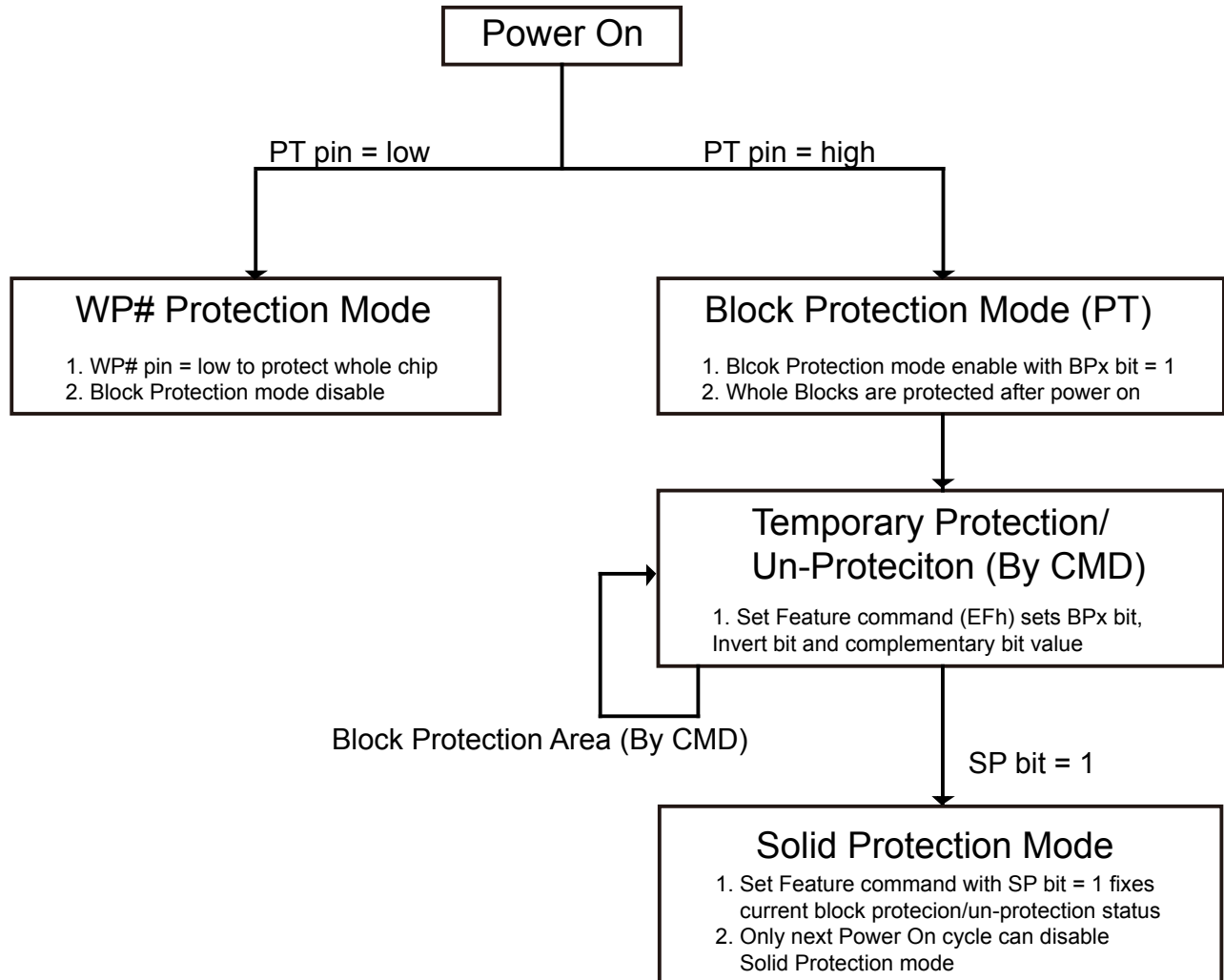

## 6-15-6. Randomizer Operation

The randomizer function is enabled on the NAND device, the user data and OTP area is scrambled in random pattern before written to the NAND device. When attempting to use the randomizer function, it is necessary to enable the randomizer function prior to program data in main array and OTP area.

The randomizer function is enabled through “set feature” operation (as "**Table 8-1. Definition of Feature Address**" and "**Table 8-7. Sub-Feature Parameter Table of Feature Address – B0h (Configuration)**").

The following feature bits RANDEN and RANDOPT is related with randomizer function (as "**Table 8-7. Sub-Feature Parameter Table of Feature Address – B0h (Configuration)**"). To enable the randomizer function, RANDEN bit must be set to “1”, RANDOPT can be set to “0” or “1” depending on the user choice (as "**Table 10. The definition of RANDOPT bit for the randomized area per page (as grey color)**").

Both RANDEN and RANDOPT feature bits are V2 type volatile bits with their default value can be changed once with the Flowchart of RANDEN and RANDOPT Bits Program Operation. The RANDEN and RANDOPT bits will return to their default value after power cycle. The RANDEN and RANDOPT bits program flowchart is shown on the "**Figure 36. Flowchart of RANDEN and RANDOPT Bits Program Operation**". To enable the program sequence, ENPGM feature bit must be set to “1”. After the program is finished, ENPGM feature bit must be set to “0” as shown in the flow.

After the RANDEN and RANDOPT feature bits are programmed, the user can issue get feature command to check the RANDEN and RANDOPT feature bits are programmed successfully or not.

RANDOPT bit: considering the needs of different applications; there are two options of randomizer coverage providing as shown in "**Table 10. The definition of RANDOPT bit for the randomized area per page (as grey color)**"). The grey data area is covered by the randomizer function for each option; whereas the white area is not.

*Note: the NOP=1 for the randomizer covered data area*

**Table 10. The definition of RANDOPT bit for the randomized area per page (as grey color)**

Density	RANDOPT	Main	Spare 0	Spare 1	Remark
1Gb	0	0000h~07FFh	0800h~081Fh	0820h~087Fh	NOP=1 for Main/Spare 0/Spare 1
	1	0000h~07FFh	0800h~081Fh	0820h~087Fh	NOP=1 for Main/Spare 1
2Gb	0	0000h~07FFh	0800h~081Fh	0820h~087Fh	NOP=1 for Main/Spare 0/Spare 1
	1	0000h~07FFh	0800h~081Fh	0820h~087Fh	NOP=1 for Main/Spare 1
4Gb	0	0000h~0FFFh	1000h~101Fh	1020h~10FFh	NOP=1 for Main/Spare 0/Spare 1
	1	0000h~0FFFh	1000h~101Fh	1020h~10FFh	NOP=1 for Main/Spare 1

Figure 36. Flowchart of RANDEN and RANDOPT Bits Program Operation

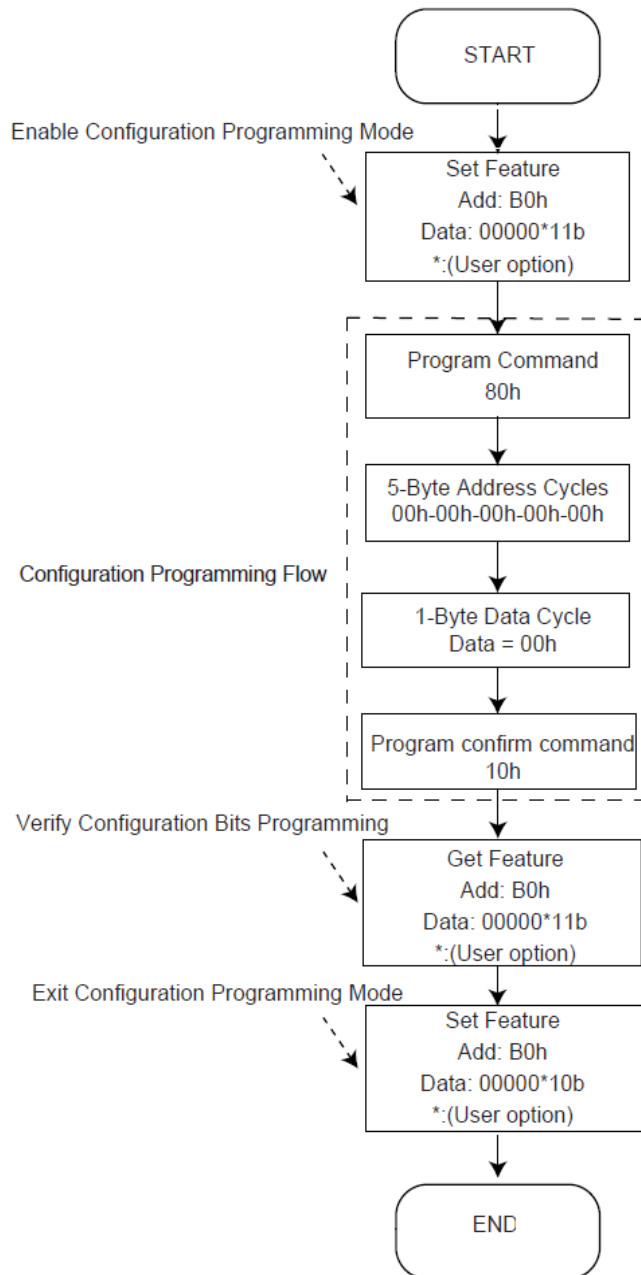

## 6-16. Two-Plane Operations (For 2Gb/4Gb)

The device is divided into two planes for performance improvement, which provides ONFI two-plane command set, and traditional two-plane command set. In the two-plane operation, the NAND device may proceed the same type operation (for example: Program or Erase) on the two planes concurrent or overlapped by the two-plane command sets. The different type operations cannot be done in the two-plane operations; for example, it cannot be done to erase one plane and program the other plane concurrently.

The plane address A18(for 2Gb) or A19(for 4Gb) must be different from each selected plane address. The page address A12-A17(for 2Gb) or A13-A18(for 4Gb) of individual plane must be the same for two-plane operation.

The Status Read command (70h) may check the device status in the two-plane operation, if the result is failed and then the Status Enhanced Read (78h) may check which plane is failed.

## 6-17. Two-Plane Program (ONFI & Traditional) & Two-Plane Cache Program (ONFI & Traditional)

The two-plane program command (80h-11h) may input data to cache buffer and wait for the final plane data input with command (80h-10h) and then transfer all data to NAND array. As for the two-plane cache program operation, it can be achieved by a two-plane program command (80h-11h) with a cache program command (80h-15h), and the final address input with the confirm command (80h-10h). Please refer to the waveforms of "**Figure 37-1. AC Waveforms for Two-plane Program (ONFI)**" and "**Figure 38. AC Waveforms for Two-plane Cache Program (ONFI)**" for details. The random data input command (85h) can be also used in the two-plane program operation for changing the column address, please refer to "**Figure 37-2. AC Waveforms for Page Program Random Data Two-plane (ONFI)**". The traditional two-plane page program and cache program commands describe in "**Figure 40. AC waveforms for Two-plane Program (Traditional)**" and "**Figure 41. AC waveforms for Two-plane Cache Program (Traditional)**".

### Notes:

1. Page number should be the same for both planes.
2. Block address [28:18] for 2Gb or [29:19] for 4Gb can be different.

For examples:

*If the user issues 80h-(block address 5h, page address 5h) -11h - 80h -  
(block address - 18h, page address 5h) - 10h,*

*the programmed page is*

- Plane 0: block address 18h, page address 5h
- Plane 1: block address 5h, page address 5h

**Note:** For 2Gb, Block address = A[28:18], page address = A[17:12]

For 4Gb, Block address = A[29:19], page address = A[18:13]

## 6-18. Two-plane Block Erase (ONFI & Traditional)

The two-plane erase command (60h-D1h) may erase the selected blocks in parallel from each plane, with setting the 1<sup>st</sup> and 2<sup>nd</sup> block address by (60h-D1h) & (60h-D0h) command and then erase two selected blocks from NAND array. Please refer to the following waveforms of two-plane erase for details. Traditional two-plane block erase command describes in "**Figure 42. AC waveforms for Two-plane Erase (Traditional)**".

Figure 37-1. AC Waveforms for Two-plane Program (ONFI)

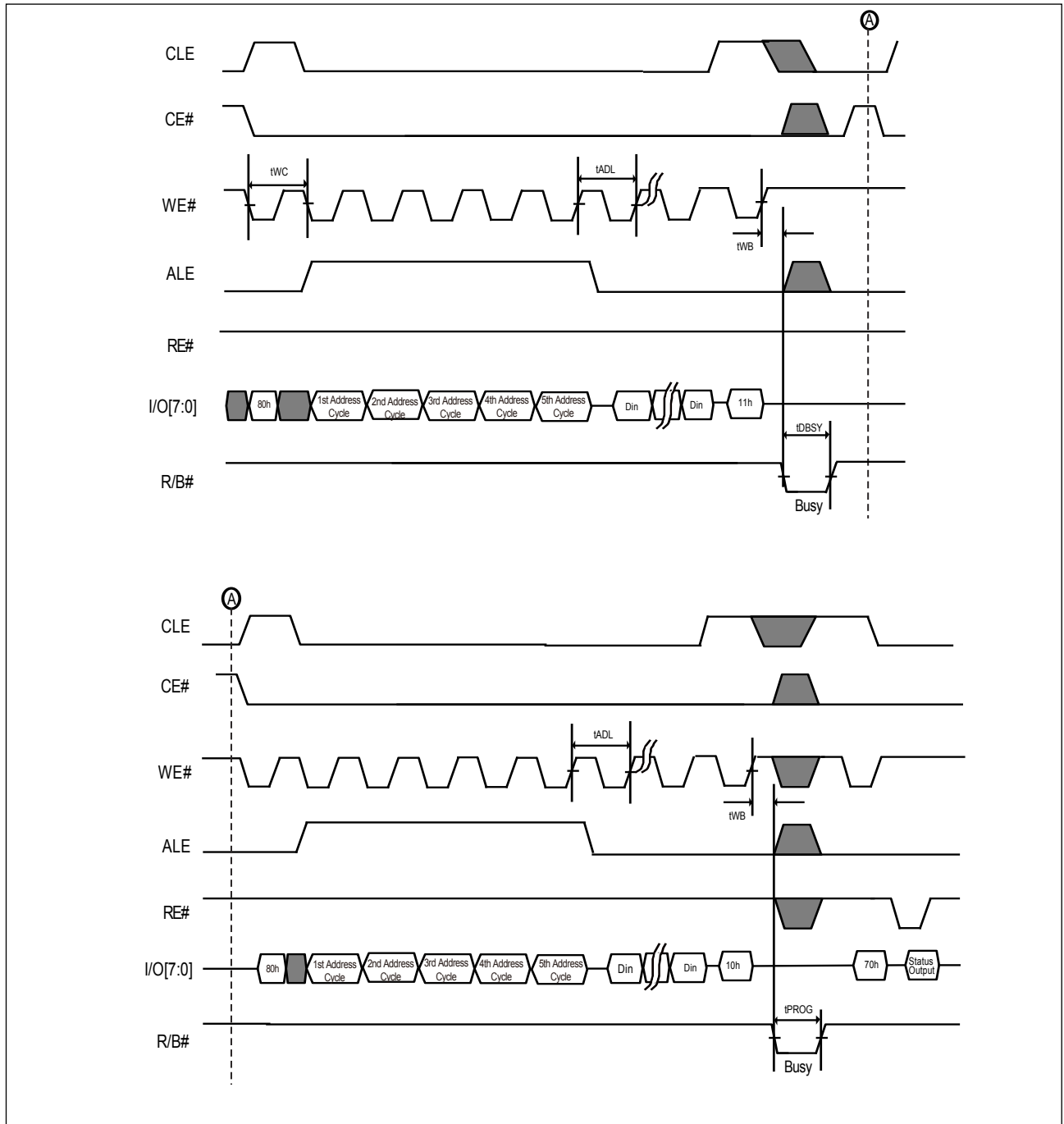
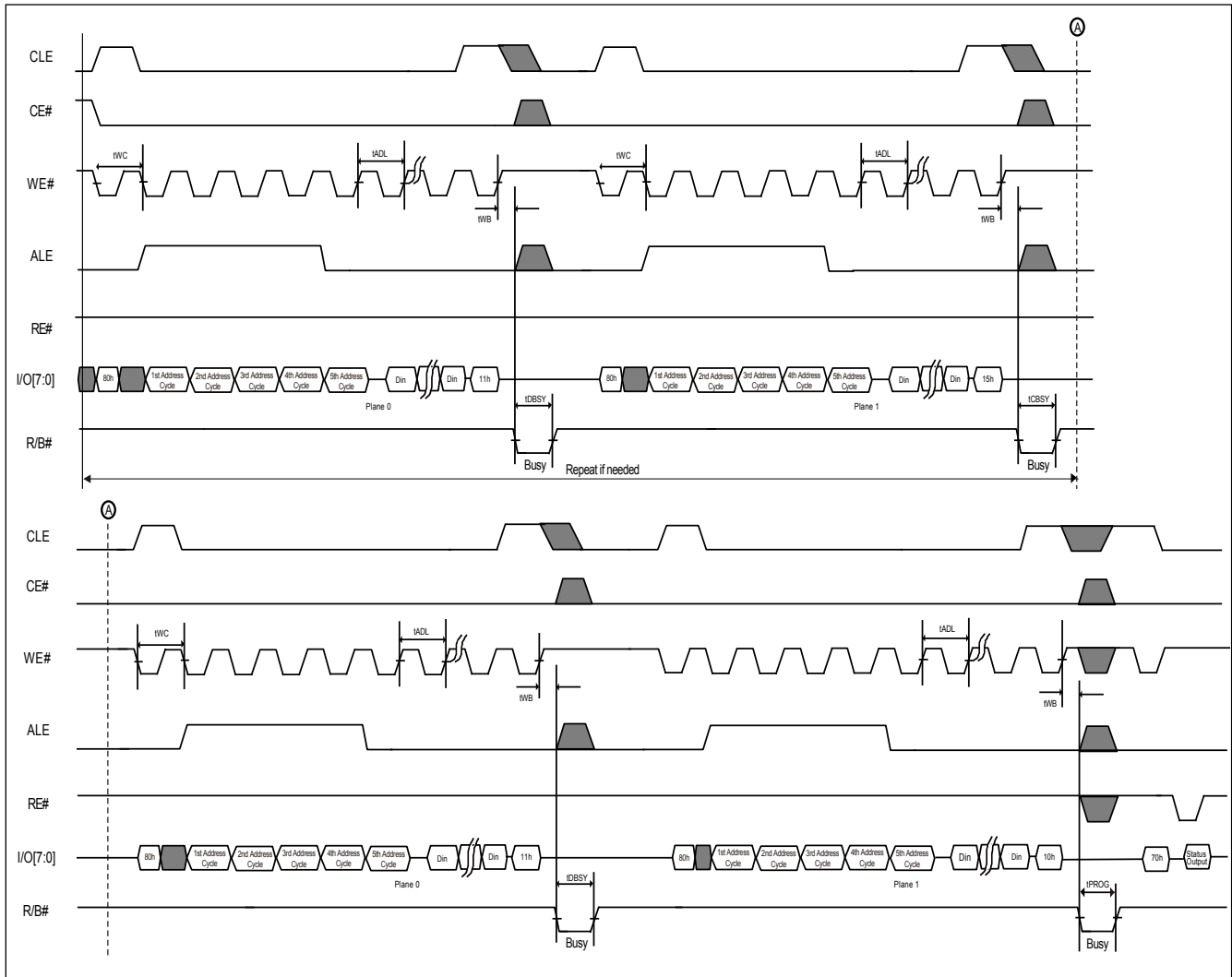

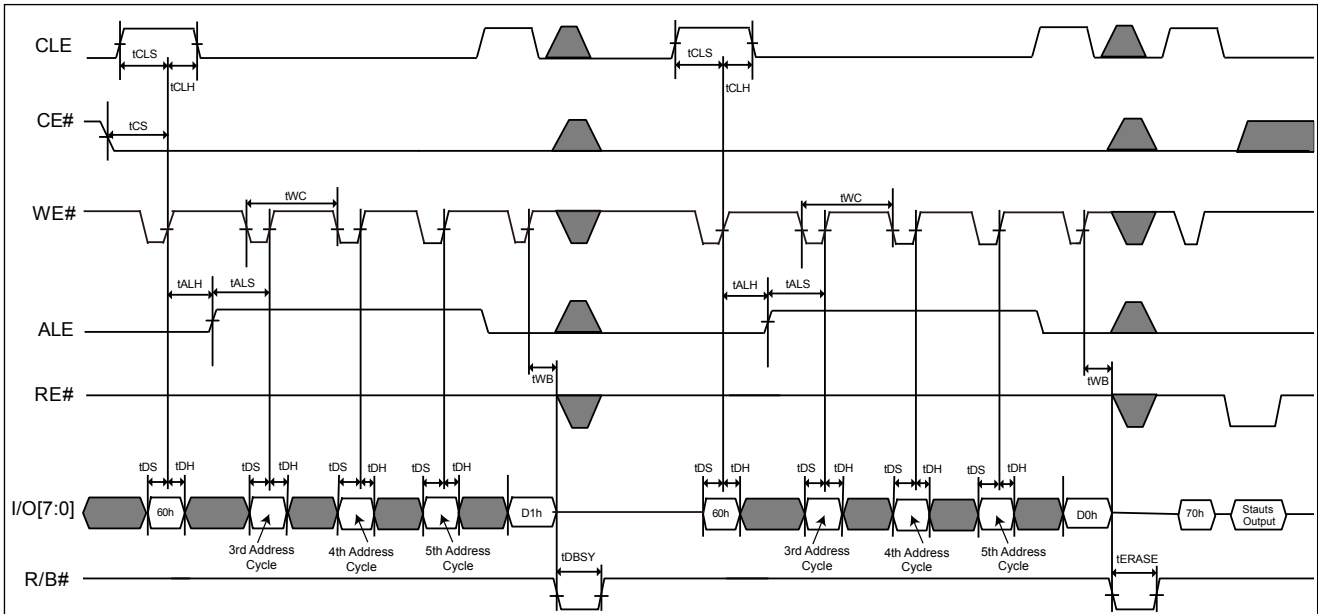

Figure 38. AC Waveforms for Two-plane Cache Program (ONFI)

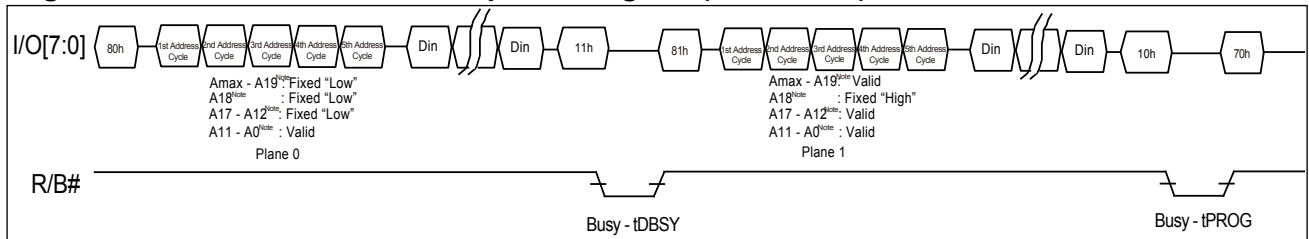



**Figure 39. AC Waveforms for Two-plane Erase (ONFI)**

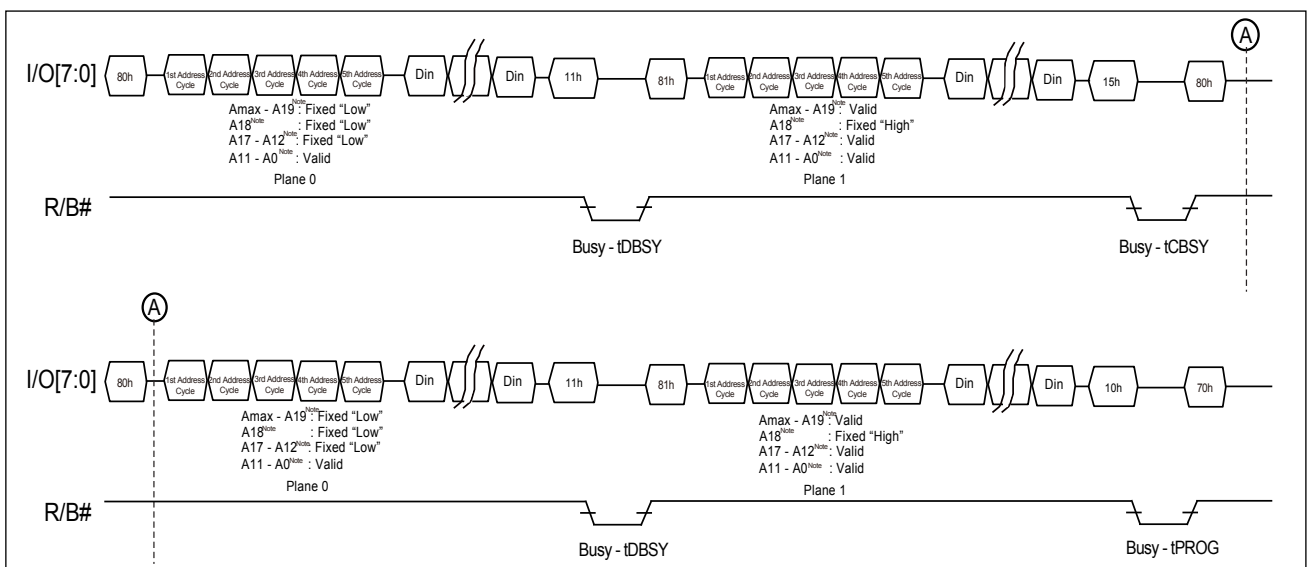

**Figure 40. AC waveforms for Two-plane Program (Traditional)**



**Note:** The above address in waveform are 2Gb example. The address for 4Gb are: Amax-A20, A19, A18-A13, A12-A0 respectively.

**Figure 41. AC waveforms for Two-plane Cache Program (Traditional)**



**Note:** The above address in waveform are 2Gb example. The address for 4Gb are: Amax-A20, A19, A18-A13, A12-A0 respectively.

**Figure 42. AC waveforms for Two-plane Erase (Traditional)**

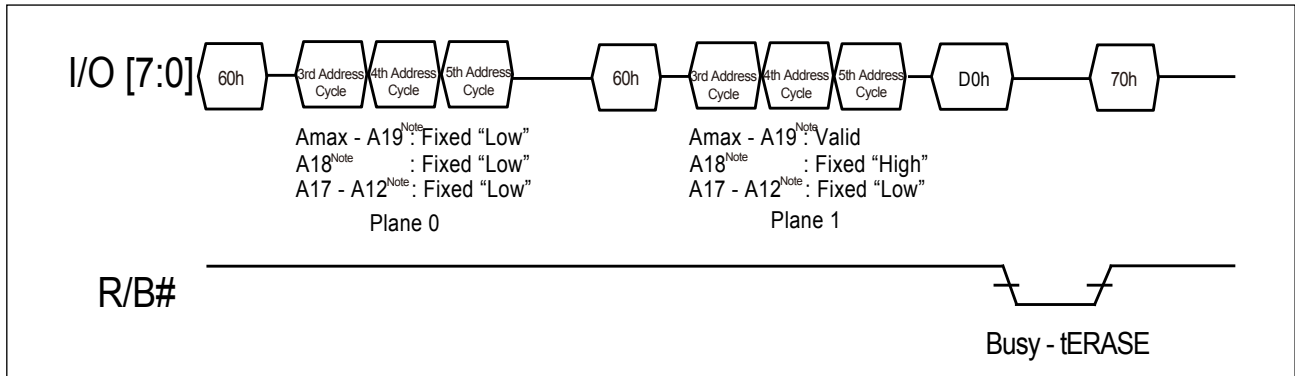

**Note:** The above address in waveform are 2Gb example. The address for 4Gb are: Amax-A20, A19, A18-A13, A12-A0 respectively.

## 7. PARAMETERS

### 7-1. ABSOLUTE MAXIMUM RATINGS

Temperature under Bias	-50°C to +125°C
Storage temperature	-65°C to +150°C
All input voltages with respect to ground (Note 2)	-0.6V to 4.6V
VCC supply voltage with respect to ground (Note 2)	-0.6V to 4.6V

**Notes:**

1. The reliability of device may be impaired by exposing to extreme maximum rating conditions for long range of time.
2. Permanent damage may be caused by the stresses higher than the "Absolute Maximum Ratings" listed.
3. During voltage transitions, all pins may overshoot Vss to -2.0V and Vcc to +2.0V for periods up to 20ns, please refer to the two waveforms as below.

Figure 43. Maximum Negative Overshoot Waveform

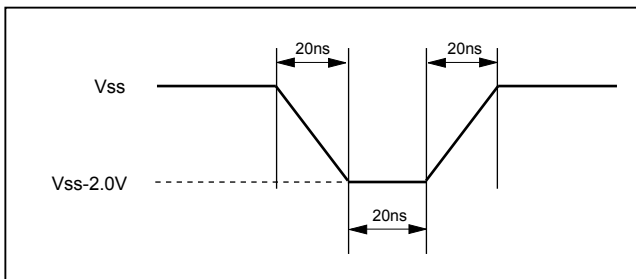
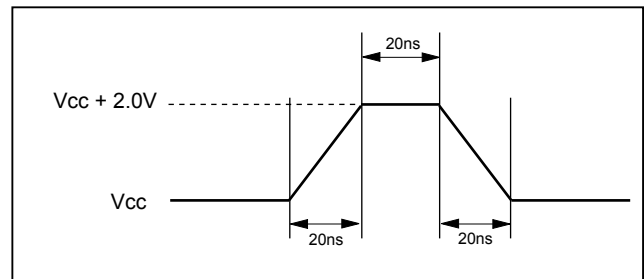

Figure 44. Maximum Positive Overshoot Waveform



### 7-2. LATCH-UP CHARACTERISTICS

	Min.	Max.
Input Voltage with respect to GND on all power pins		1.5 VCCmax
Input current with respect to GND on all non-power pins	-100mA	+100mA
Test conditions are compliant to JEDEC JESD78 standard		

**Table 11. Operating Range**

Temperature	VCC	Tolerance
-40°C to +85°C	+3.3V	2.7 - 3.6V

**Table 12. DC Characteristics**

Symbol	Parameter	Test Conditions	Min.	Typical	Max.	Unit	Notes
VIL	Input low level		-0.3		0.2VCC	V	
VIH	Input high level		0.8VCC		VCC + 0.3	V	
VOL	Output low voltage	IOL = 2.1mA, VCC = VCC Min.			0.2	V	
VOH	Output high voltage	IOH = -400uA, VCC = VCC Min.	VCC-0.2			V	
ISB1	VCC standby current (CMOS)	CE# = VCC -0.2V, WP# = 0/VCC		10	50	uA	
ISB2	VCC standby current (TTL)	CE# = VIH Min., WP# = 0/VCC			1	mA	
ICC0	Power on current (Including POR current)				50	mA	
ICC1	VCC active current (Sequential Read)	tRC Min., CE# = VIL, IOOUT = 0mA		20	30	mA	
ICC2	VCC active current (Program)			20 <sup>(Note)</sup>	30	mA	
ICC3	VCC active current (Erase)			15	30	mA	
ILI	Input leakage current	VIN = 0 to VCC Max.			+/- 10	uA	
ILO	Output leakage current	VOUT = 0 to VCC Max.			+/- 10	uA	
IOL (R/B#)	Output current of R/B# pin	VOL = 0.4V	8	10		mA	

**Note:** The typical program current (ICC2) for two-plane program operation is 25mA.

**Table 13. Capacitance**

TA = +25°C, F = 1 MHz

Symbol	Parameter	Typ.	Max.	Units	Conditions
CIN	Input capacitance		10	pF	VIN = 0 V
COUT	Output capacitance		10	pF	VOUT = 0 V

**Table 14. AC Testing Conditions**

Testing Conditions	Value	Unit
Input pulse level	0 to VCC	V
Output load capacitance	1TTL+CL(50)	pF
Input rise and fall time	5	ns
Input timing measurement reference levels	VCC/2	V
Output timing measurement reference levels	VCC/2	V

**Table 15. Program and Erase Characteristics**

Symbol	Parameter	Min.	Typ.	Max.	Unit	Note
tPROG	Page programming time		320	700	us	
tPROG_RAND	Page programming time (Randomizer enabled)		360	740	us	
tCBSY (Program)	Dummy busy time for cache program		5	700	us	
tCBSY_RAND (Program)	Dummy busy time for cache program (Randomizer enabled)		30	740	us	
tRCBSY (Read)	Dummy busy time for cache read		4.5	25	us	
tDBSY	The busy time for two-plane program/erase operation		0.5	1	us	
tFEAT	The busy time for Set Feature/ Get Feature			1	us	
tOBSY	The busy time for OTP program at OTP protection mode			30	us	
tPBSY	The busy time for program/erase at protected blocks			3	us	
NOP	Number of partial program cycles in same page			4	cycles	1
tERASE (Block)	Block erase time		4	6	ms	2

**Note 1.** NOP=1 for the randomizer covered data area when the randomizer is enabled.

**Note 2.** The tERASE of two-plane will be 4ms(typical) and 7ms(Maximum).

**Table 16. AC Characteristics**

Symbol	Parameter	Min.	Typ.	Max.	Unit	Note
tCLS	CLE setup time	10			ns	1
tCLH	CLE hold time	5			ns	1
tCS	CE# setup time	15			ns	1
tCH	CE# hold time	5			ns	1
tWP	Write pulse width	10			ns	1
tALS	ALE setup time	10			ns	1
tALH	ALE hold time	5			ns	1
tDS	Data setup time	7			ns	1
tDH	Data hold time	5			ns	1
tWC	Write cycle time	20			ns	1
tWH	WE# high hold time	7			ns	1
tADL	Last address latched to data loading time during program operations	70			ns	1
tWW	WP# transition to WE# high	100			ns	1
tRR	Ready to RE# falling edge	20			ns	1
tRP	Read pulse width	10			ns	1
tRC	Read cycle time	20			ns	1
tREA	RE# access time (serial data access)			16	ns	1
tCEA	CE# access time			25	ns	1
tRLOH	RE#-low to data hold time (EDO)	5			ns	
tOH	Data output hold time	15			ns	1
tRHZ	RE#-high to output-high impedance			60	ns	1
tCHZ	CE#-high to output-high impedance			50	ns	1
tCOH	CE# high to output hold time	15			ns	
tREH	RE# high hold time	7			ns	1
tIR	Output high impedance to RE# falling edge	0			ns	1
tRHW	RE# high to WE# low	60			ns	1
tWHR	WE# high to RE# low	60			ns	1
tR	The data transferring from array to buffer			25	us	1
tWB	WE# high to busy			100	ns	1
tCLR	CLE low to RE# low	10			ns	1
tAR	ALE low to RE# low	10			ns	1
tRST	Device reset time (Idle/ Read/ Program/ Erase)			5/5/10/500	us	1

**Note 1.** ONFI Mode 5 compliant

## 8. OPERATION MODES: LOGIC AND COMMAND TABLES

Address input, command input and data input/output are managed by the CLE, ALE, CE#, WE#, RE# and WP# signals, as shown in "Table 17. Logic Table" below.

Program, Erase, Read and Reset are four major operations modes controlled by command sets, please refer to "Table 18-1. HEX Command Table" and "Table 18-2. Two-plane Command Set (For 2Gb/4Gb)".

**Table 17. Logic Table**

Mode	CE#	RE#	WE#	CLE	ALE	WP#
Address Input (Read Mode)	L	H	↑	L	H	X
Address Input (Write Mode)	L	H	↑	L	H	H
Command Input (Read Mode)	L	H	↑	H	L	X
Command Input (Write Mode)	L	H	↑	H	L	H
Data Input	L	H	↑	L	L	H
Data Output	L	↓	H	L	L	X
During Read (Busy)	X	H	H	L	L	X
During Programming (Busy)	X	X	X	X	X	H
During Erasing (Busy)	X	X	X	X	X	H
Program/Erase Inhibit	X	X	X	X	X	L
Stand-by	H	X	X	X	X	0V/VCC

**Notes:**

1. H = VIH; L = VIL; X = VIH or VIL
2. WP# should be biased to CMOS high or CMOS low for stand-by.

Table 18-1. HEX Command Table

	First Cycle	Second Cycle	Acceptable While Busy
Read Mode	00H	30H	
Random Data Input	85H	-	
Random Data Output	05H	E0H	
Cache Read Random	00H	31H	
Cache Read Sequential	31H	-	
Cache Read End	3FH	-	
ID Read	90H	-	
Parameter Page Read (ONFI)	ECH	-	
Unique ID Read (ONFI)	EDH	-	
Set Feature (ONFI)	EFH	-	
Get Feature (ONFI)	EEH	-	
Reset	FFH	-	V
Page Program	80H	10H	
Cache Program (Start)	80H	15H	
Cache Program (End)	80H	10H	
Block Erase	60H	D0H	
Status Read	70H	-	V
Status Enhanced Read (ONFI) <sup>Note</sup>	78H	-	V
Block Protection Status Read	7AH	-	

*Note: Status Enhanced Read (ONFI) command is supported on 2Gb/4Gb.*

Table 18-2. Two-plane Command Set (For 2Gb/4Gb)

	First Cycle	Second Cycle	Third Cycle	Fourth Cycle
Two-plane Program (ONFI)	80H	11H	80H	10H
Two-plane Cache Program - Start/Cont. (ONFI)	80H	11H	80H	15H
Two-plane Cache Program - End (ONFI)	80H	11H	80H	10H
Two-plane Block Erase (ONFI)	60H	D1H	60H	D0H
Two-plane Program (Traditional)	80H	11H	81H	10H
Two-Plane Cache Program - Start/Cont. (Traditional)	80H	11H	81H	15H
Two-Plane Cache Program - End (Traditional)	80H	11H	81H	10H
Two-plane Erase (Traditional)	60H	60H	D0H	

**Caution:** None of the undefined command inputs can be accepted except for the command set in the table above.



## 8-1. R/B#: Termination for The Ready/Busy# Pin (R/B#)

The R/B# is an open-drain output pin and a pull-up resistor is necessary to add on the R/B# pin. The R/B# outputs the ready/busy status of read/program/ erase operation of the device. When the R/B# is at low, the device is busy for read or program or erase operation. When the R/B# is at high, the read/program/erase operation is finished.

### Rp Value Guidance

The rise time of the R/B# signal depends on the combination of Rp and capacitive loading of the R/B# circuit. It is approximately two times constants (Tc) between the 10% and 90% points on the R/B# waveform.

$$T_c = R \times C$$

Where R = Rp (Resistance of pull-up resistor), and C = CL (Total capacitive load)

The fall time of the R/B# signal majorly depends on the output impedance of the R/B# signal and the total load capacitance.

$$R_p (\text{Min.}) = \frac{V_{cc} (\text{Max.}) - V_{OL} (\text{Max.})}{I_{OL} + \sum I_L}$$

#### Notes:

1. Considering of the variation of device-by-device, the above data is for reference to decide the resistor value.
2. Rp maximum value depends on the maximum permissible limit of tr.
3. IL is the total sum of the input currents of all devices tied to the R/B pin.

Figure 45. R/B# Pin Timing Information

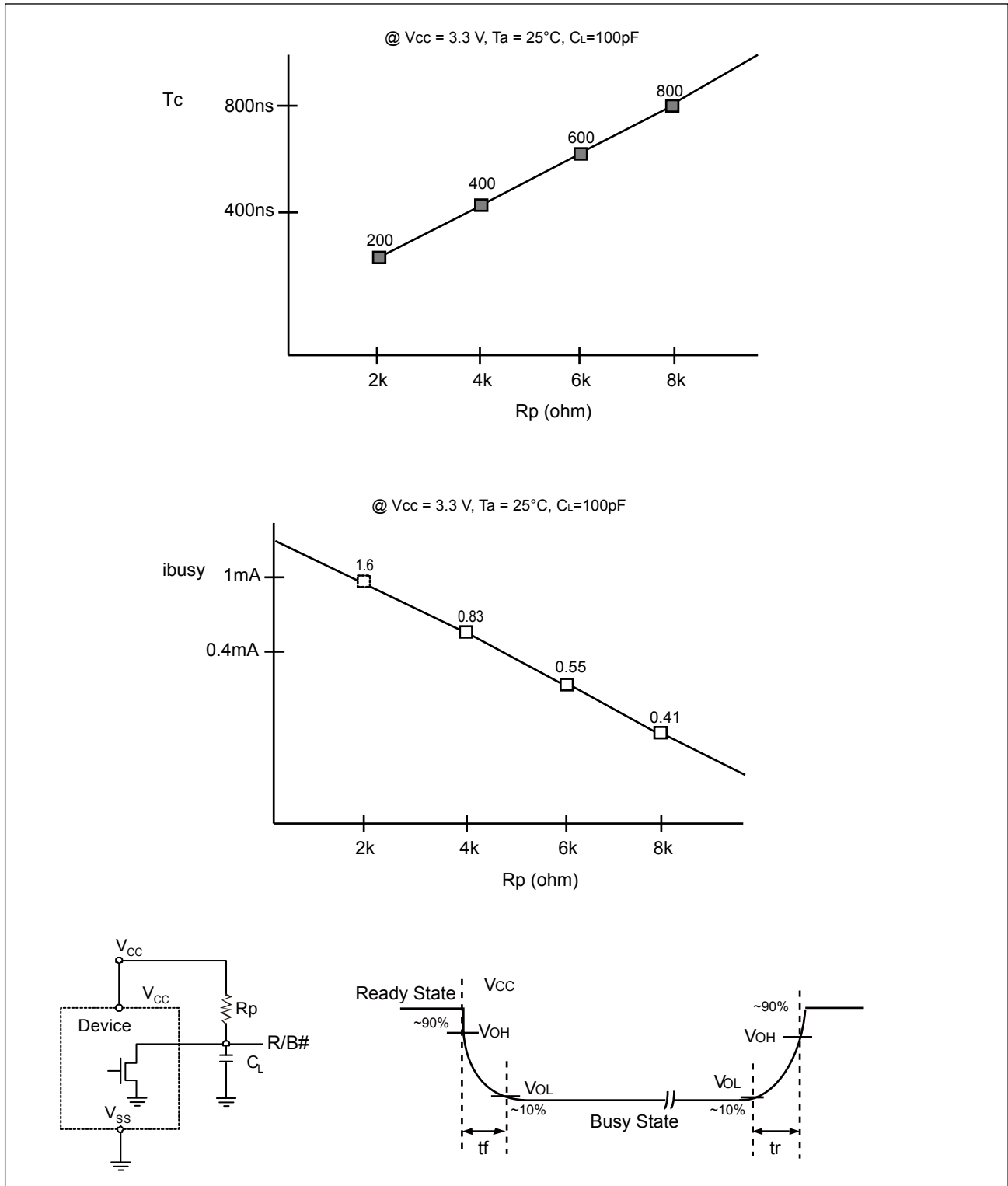

## 8-2. Power On/Off Sequence

After the Chip reaches the power on level ( $V_{th} = V_{cc \text{ min.}}$ ), the internal power on reset sequence will be triggered. During the internal power on reset period, no any external command is accepted. There are two ways to identify the termination of the internal power on reset sequence. Please refer to "Figure 46. Power On/Off Sequence".

- R/B# pin
- Wait 5 ms

During the power on and power off sequence, it is recommended to keep the WP# = Low for internal data protection. It is recommended the CE# needs to follow the voltage applied on VCC to keep the device not to be selected.

Figure 46. Power On/Off Sequence

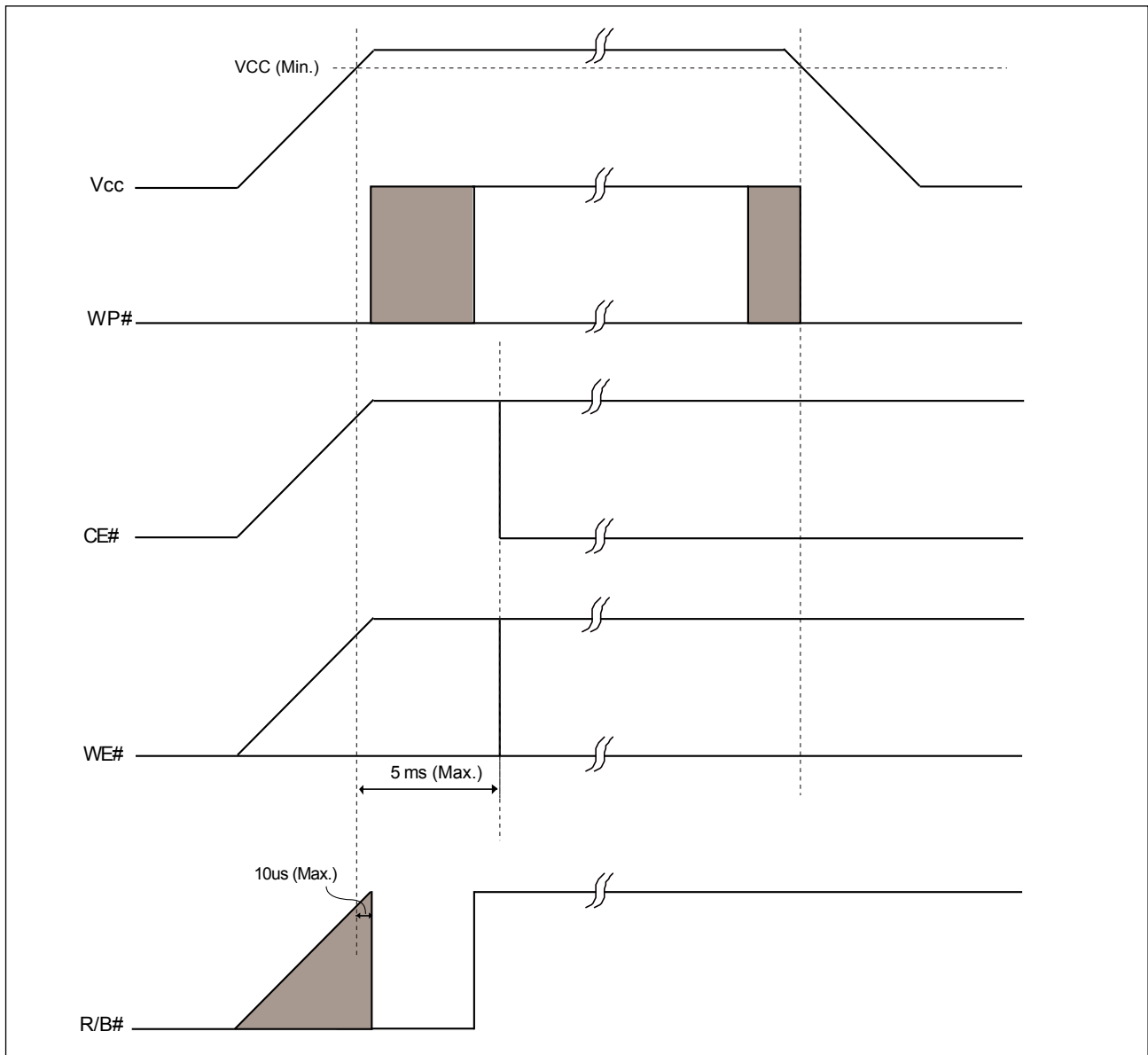

### 8-2-1. WP# Signal

WP# going Low can cause program and erase operations automatically reset.

The enabling & disabling of the both operations are as below:

**Figure 47-1. Enable Programming of WP# Signal**

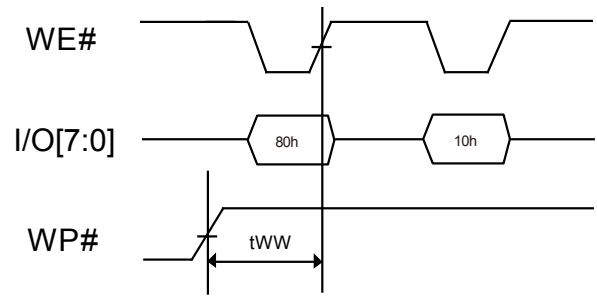

**Figure 47-2. Disable Programming of WP# Signal**

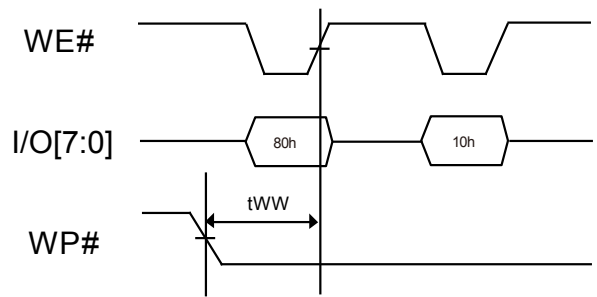

**Figure 47-3. Enable Erasing of WP# Signal**

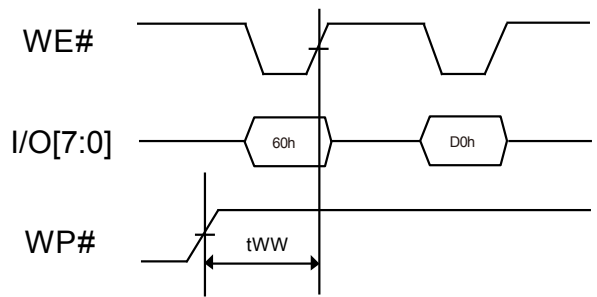

**Figure 47-4. Disable Erasing of WP# Signal**

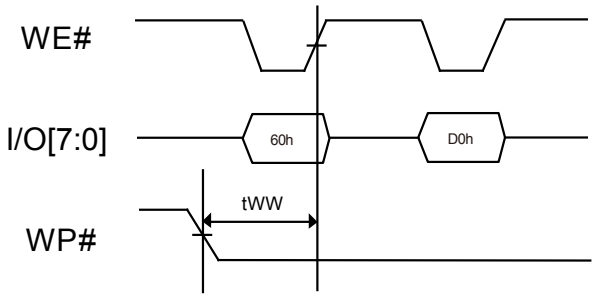

## 9. SOFTWARE ALGORITHM

### 9-1. Invalid Blocks (Bad Blocks)

The bad blocks are included in the device while it gets shipped. During the time of using the device, the additional bad blocks might be increasing; therefore, it is recommended to check the bad block marks and avoid using the bad blocks. Furthermore, please read out the bad block information before any erase operation since it may be cleared by any erase operation.

**Figure 48. Bad Blocks**

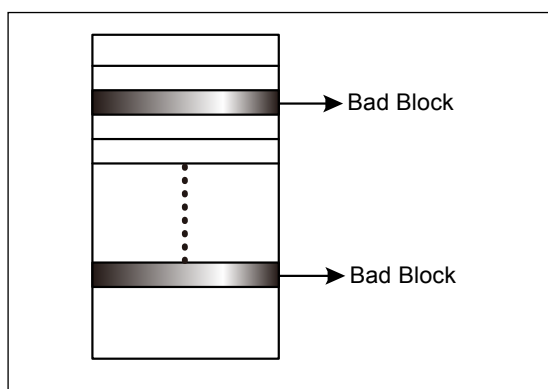

While the device is shipped, the value of all data bytes of the good blocks are FFh. The 1st byte of the 1st and 2nd page in the spare area for bad block will be 00h. The erase operation at the bad blocks is not recommended.

After the device is installed in the system, the bad block checking is recommended. The figure shows the brief test flow by the system software managing the bad blocks while the bad blocks were found. When a block gets damaged, it should not be used any more.

Due to the blocks are isolated from bit-line by the selected gate, the performance of good blocks will not be impacted by bad ones.

**Table 19. Valid Blocks**

	Density	Min.	Typ.	Max.	Unit	Remark
Valid (Good) Block Number	1Gb	1004		1024	Block	Block#0-7 are guaranteed to be good at the time of shipment (with (with ECC implementation by host).
	2Gb	2008		2048	Block	
	4Gb	2008		2048	Block	

**Note:** The total good block numbers will not be less than minimum good block numbers during the NAND device lifetime.

## 9-2. Bad Block Test Flow

Although the initial bad blocks are marked by the flash vendor, they could be inadvertently erased and destroyed by a user that does not pay attention to them. To prevent this from occurring, it is necessary to always know where any bad blocks are located. Continually checking for bad block markers during normal use would be very time consuming, so it is highly recommended to initially locate all bad blocks and build a bad block table and reference it during normal NAND flash use. This will prevent having the initial bad block markers erased by an unexpected program or erase operation. Failure to keep track of bad blocks can be fatal for the application. For example, if boot code is programmed into a bad block, a boot up failure may occur. The following section shows the recommended flow for creating a bad block table.

Figure 49. Bad Block Test Flow

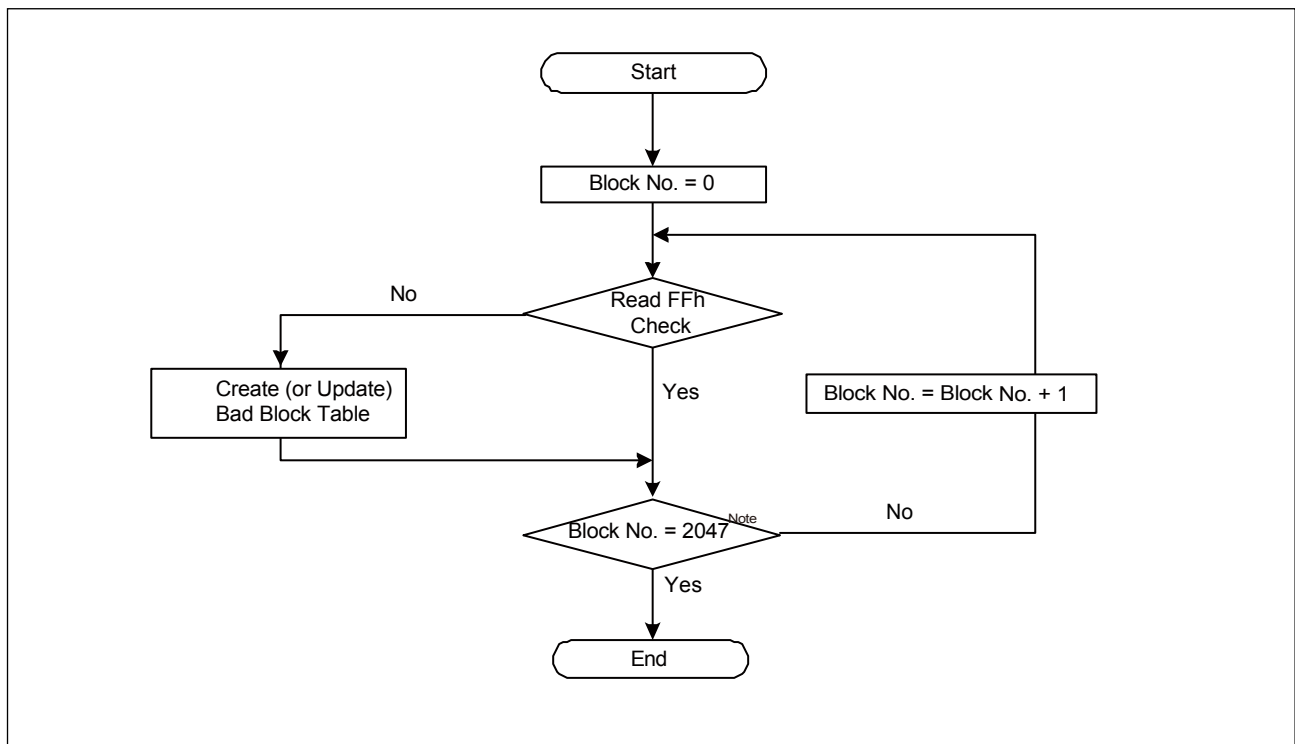

*Note: Block No. = 1023 for 1Gb*

## 9-3. Failure Phenomena for Read/Program/Erase Operations

The device may fail during a Read, Program or Erase operation. The following possible failure modes should be considered when implementing a highly reliable system:

Table 20. Failure Modes

Failure Mode	Detection and Countermeasure	Sequence
Erasing Failure	Status Read after Erase	Block Replacement
Programming Failure	Status Read after Program	Block Replacement
Read Failure	Read Failure	ECC

## 9-4. Program

It is feasible to reprogram the data into another page (Page B) when an error occurred in Page A by loading from an external buffer. Then create a bad block table or by using another appropriate scheme to prevent further system accesses to Page A.

**Figure 50. Failure Modes**

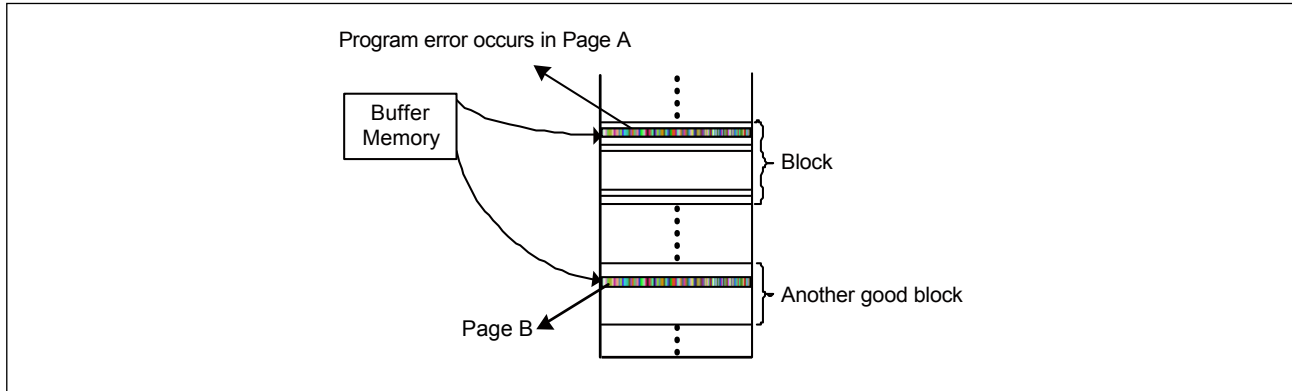

**Figure 51. Program Flow Chart**

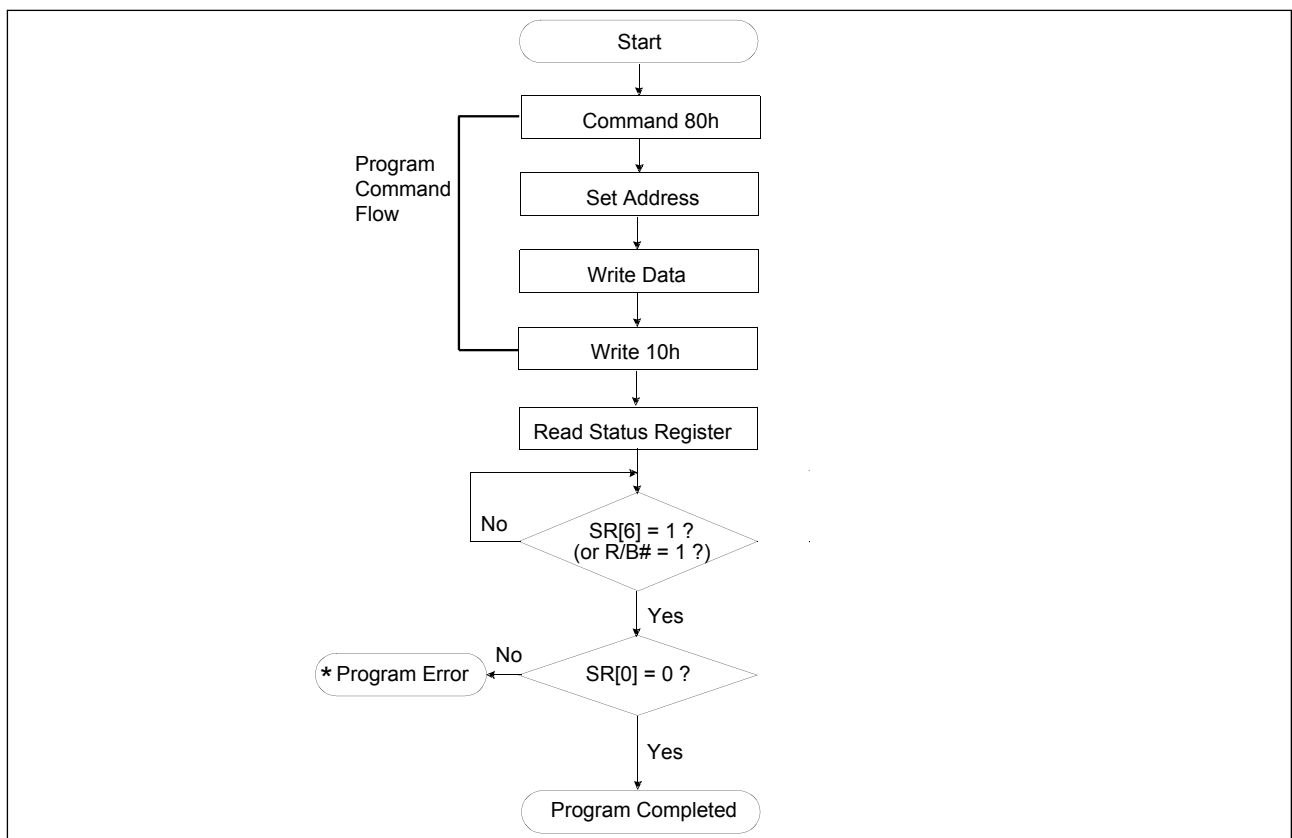

## 9-5. Erase

To prevent future accesses to this bad block, it is feasible to create a table within the system or by using another appropriate scheme when an error occurs in an Erase operation.

Figure 52. Erase Flow Chart

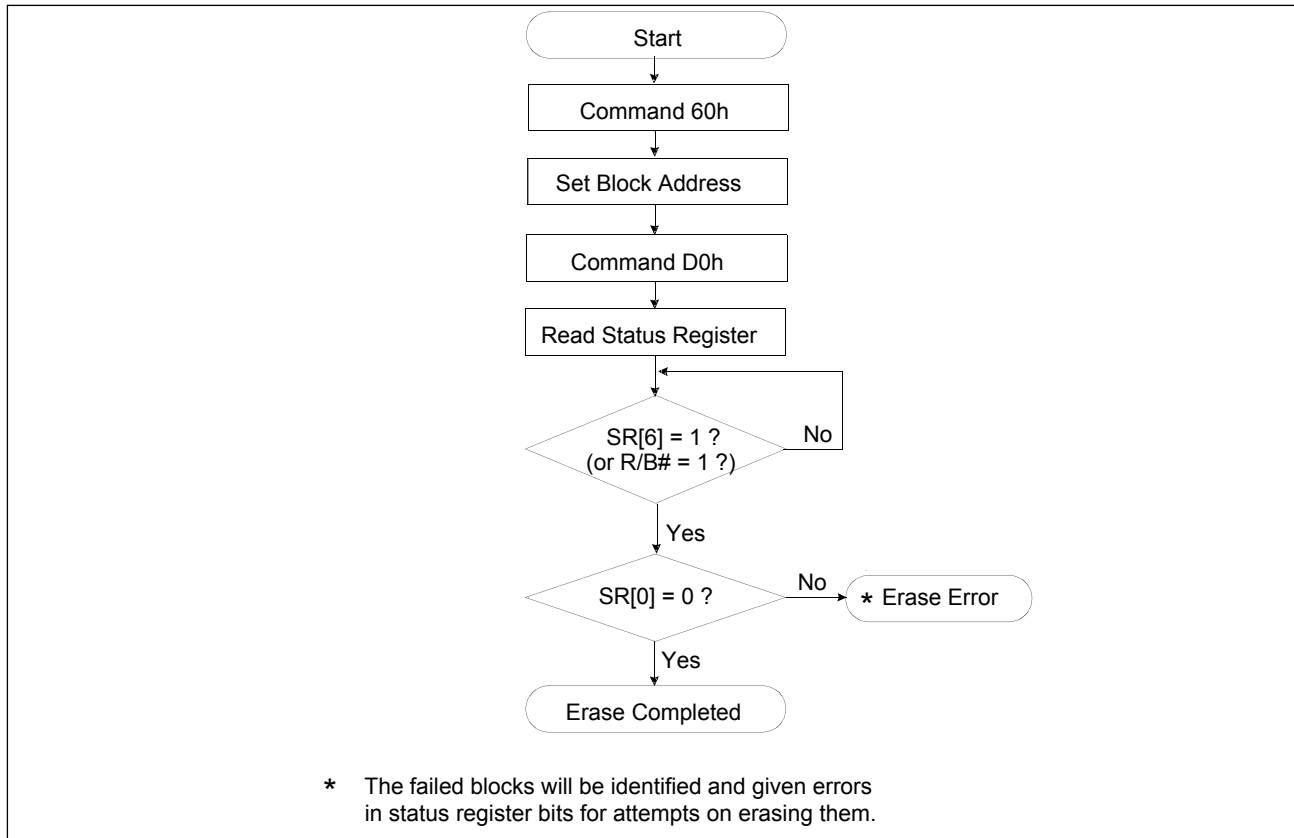
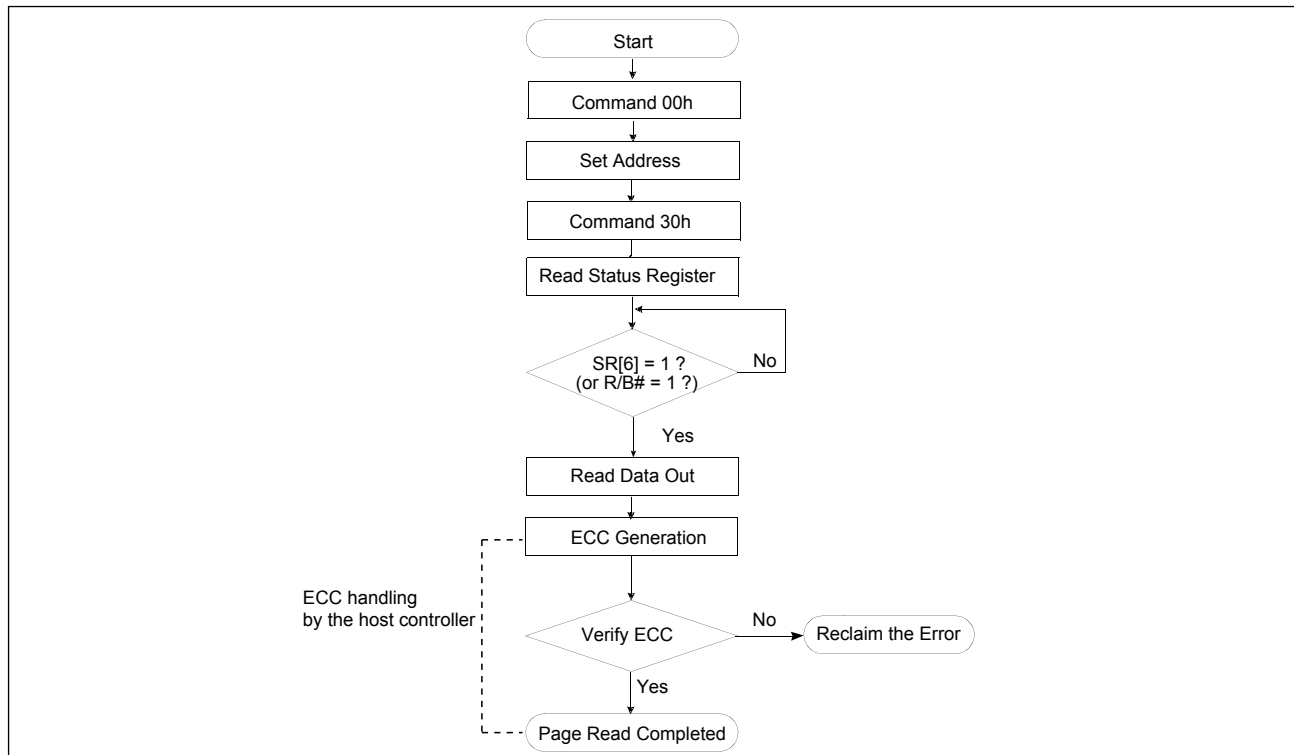

Figure 53. Read Flow Chart





## 10. PACKAGE INFORMATION

### 10-1. 48-TSOP(I) (12mm x 20mm)

Doc. Title: Package Outline for TSOP(I) 48L (12X20mm)NORMAL FORM

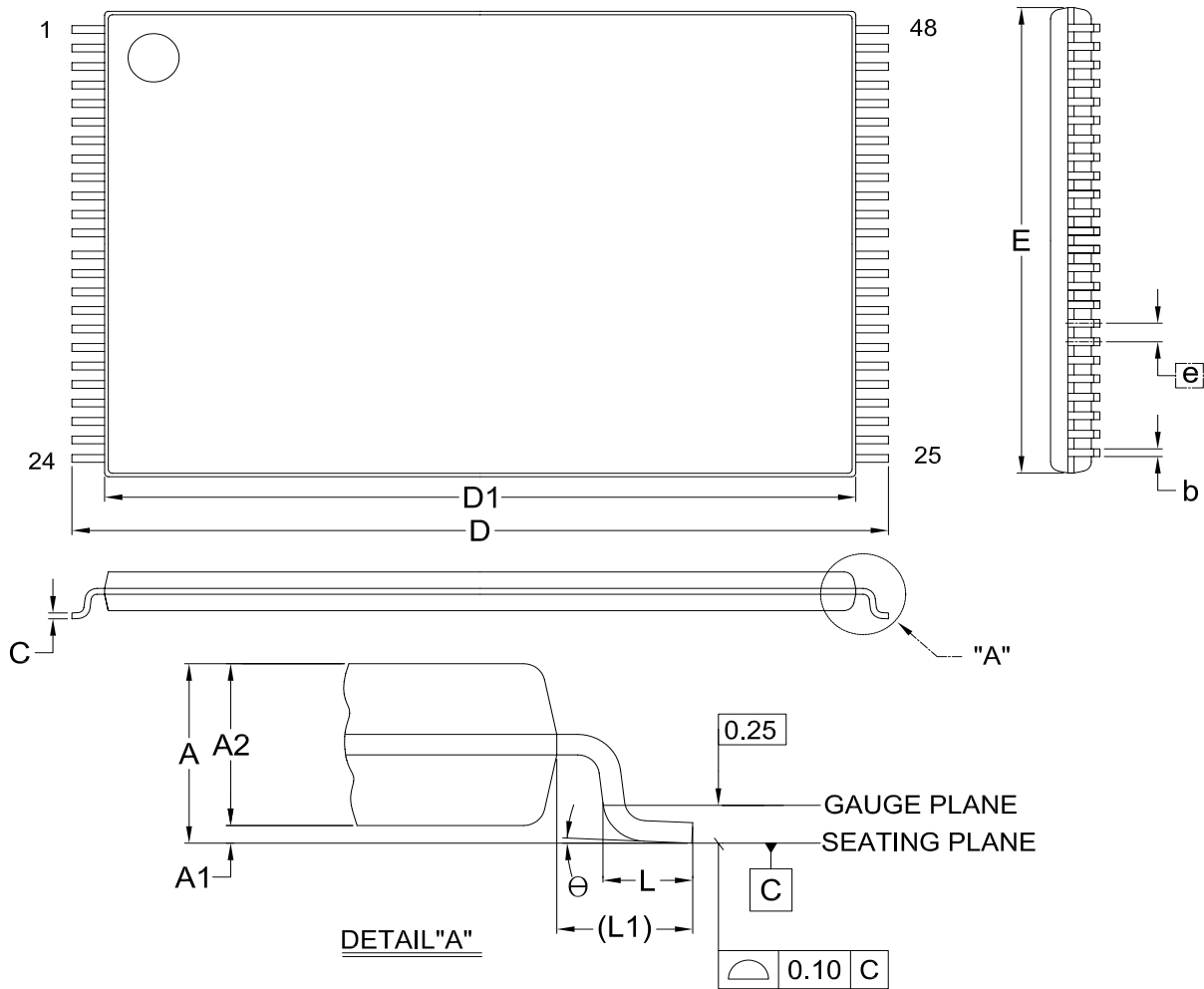

Dimensions (inch dimensions are derived from the original mm dimensions)

SYMBOL		A	A1	A2	b	C	D	D1	E	e	L	L1	Θ
UNIT													
mm	Min.	—	0.05	0.95	0.17	0.10	19.80	18.30	11.90	—	0.50	0.70	0°
	Nom.	—	0.10	1.00	0.20	0.13	20.00	18.40	12.00	0.50	0.60	0.80	5°
	Max.	1.20	0.15	1.05	0.27	0.21	20.20	18.50	12.10	—	0.70	0.90	8°
Inch	Min.	—	0.002	0.037	0.007	0.004	0.780	0.720	0.469	—	0.020	0.028	0°
	Nom.	—	0.004	0.039	0.008	0.005	0.787	0.724	0.472	0.020	0.024	0.031	5°
	Max.	0.047	0.006	0.041	0.011	0.008	0.795	0.728	0.476	—	0.028	0.035	8°

## 10-2. 63-ball 9mmx11mm VFBGA

Title: Package Outline for 63-VFBGA (9x11x1.0mm, Ball-pitch: 0.8mm, Ball-diameter: 0.45mm)

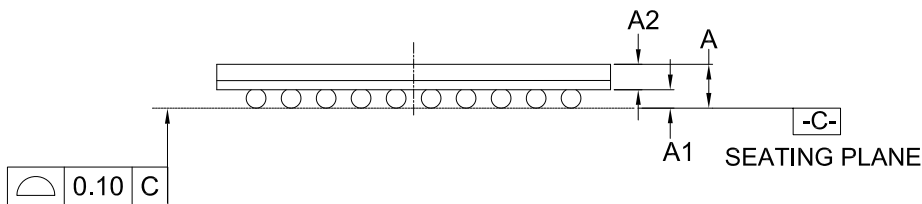
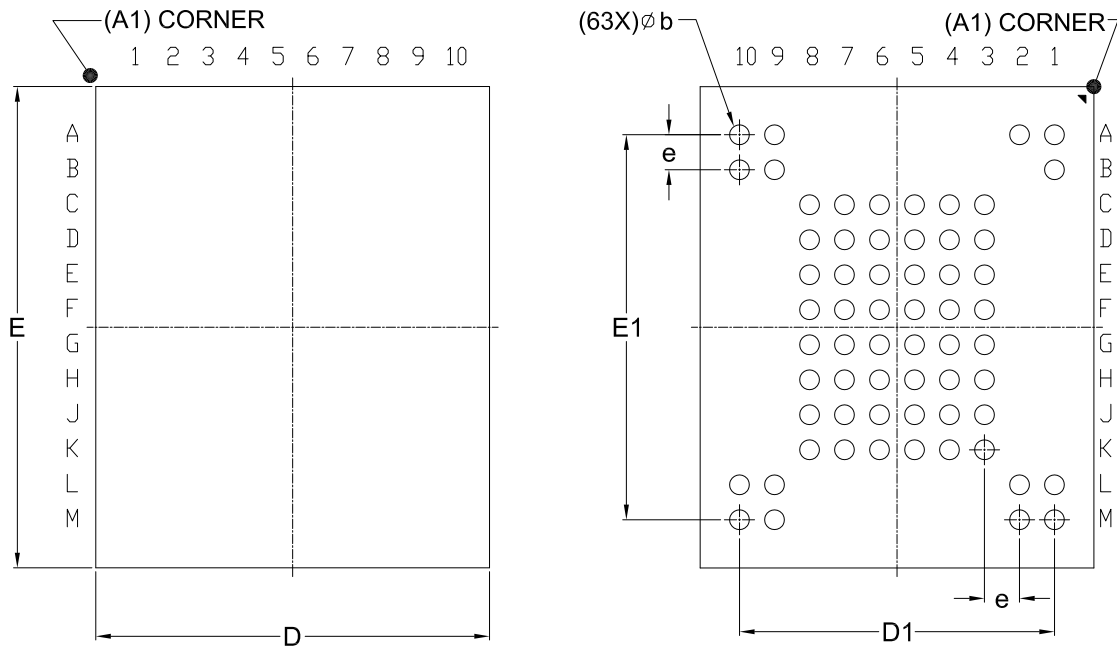

Dimensions (inch dimensions are derived from the original mm dimensions)

SYMBOL		A	A1	A2	b	D	D1	E	E1	e
UNIT										
mm	Min.	—	0.25	0.55	0.40	8.90	—	10.90	—	—
	Nom.	—	0.30	—	0.45	9.00	7.20	11.00	8.80	0.80
	Max.	1.00	0.40	—	0.50	9.10	—	11.10	—	—
Inch	Min.	—	0.010	0.022	0.016	0.350	—	0.429	—	—
	Nom.	—	0.012	—	0.018	0.354	0.283	0.433	0.346	0.031
	Max.	0.039	0.016	—	0.020	0.358	—	0.437	—	—

## 11. REVISION HISTORY

Revision	Descriptions	Page
<b>February 05, 2018</b>		
0.00	1. Initial Released	ALL
<b>November 06, 2018</b>		
0.01	1. Changed the 3rd byte Device ID from 95h to 91h	P33-34
	2. Updated ONFI Table - Byte#167 parameter value	P44
<b>February 11, 2019</b>		
0.02	1. Improved the good block at shipping from Block#0 to Block#0-7	P6
	2. Revise performance of typical tPROG/tPROG_RAND as 320us/360us, and tERASE(1-plane) as typical 3.2ms/ maximum 6ms. Adding tERASE(2-plane) spec.	P6,71
	3. Modified ONFI parameter table content to reflect the revised max. erase time, valid block number at shipping, and added more copies.	P41,43,44
	4. Supplement NOP=1 statement for those NVM data of features data	P47
	5. Supplement the OTP data is scrambled if the randomizer is enable	P53,60
	6. Adding Latch-up characteristics	P69
<b>June 05, 2019</b>		
0.03	1. Corrected bit name of ENPGM bit	P49
	2. Corrected note of ONFI parameter table from three copies to eight.	P44
	2. Revised the Table 10. The definition of RANDOPT bit for the randomized area per page	P60
	3. To supplement the randomizer function needs to be enabled prior to program data in main area and OTP	P60
	4. Supplement of each stage in Flowchart of RANDEN and RANDOPT Bits Program Operation	P61
	5. Corrected tDP spec and added the tDP_RAND spec	P72
	6. Changed the symbol of ILO(R/B#) to IOL(R/B#)	P72
	7. Corrected the symbol of tDP_NAND to tDP_RAND	P72
	8. Removed the statement of the DPD operation must be in chip idle stage. Separated waveform into "stand-by state" and "busy state" as Figure 43-1 & 43-2	P68, P74
	9. Changed page title from "Advanced Information" to "Preliminary"	ALL
<b>August 12, 2019</b>		
0.04	1. Combined the MX30LF1G28AD, MX30LF2G28AD, and MX30LF4G28AD as same datasheet file	ALL
	2. New Adding of Byte#169 of Parameter Page definition	P45,47,49
	3. Modified the statement for those non-volatile feature set data (e.g. I/O Drive strength, RANDOPT, RANDEN..., etc.): from "should be" to "is suggested to" programmed together at one time (NOP=1)	P52
<b>December 03, 2019</b>		
1.0	1. Modified document title as production version and added "preliminary stage" mark on 1Gb/2Gb product	ALL
	2. Added a note about Reliability report.	P6
	3. Modified ICC1/ICC2/tCBSY_RAND/tERASE/tRCBSY typical spec	P76,77
	4. Aligned the address term on Table 1-1/1-2/1-3 and Table 6-1/6-2/6-3, and Figure 21.	P39-40
<b>January 02, 2020</b>		
1.1	Removed Deep Power-Down mode	P6,74,75,77,79



---

<b>Revision</b>	<b>Descriptions</b>	<b>Page</b>
<b>February 21, 2020</b>		
1.2	1. Changed the status of 1Gb and 2Gb from preliminary stage to production stage	P8
	2. Re-word the "related mode" for SR[7]	P36
	3. Re-word the status of Block protection	P64
	4. Supplement of detailed figure title and table title in Randomizer Operation section	P66
<b>August 04, 2022</b>		
1.3	1. Corrected the description of particular feature bits (e.g. I/O Drive Strength, RANDOPT, RANDEN, etc.) as V2 type bits and added flowchart of I/O Drive Strength Bits Program operation	P52, 54-55, 67-68



MACRONIX  
INTERNATIONAL CO., LTD.

**MX30LF1G28AD**  
**MX30LF2G28AD**  
**MX30LF4G28AD**

---

Except for customized products which have been expressly identified in the applicable agreement, Macronix's products are designed, developed, and/or manufactured for ordinary business, industrial, personal, and/or household applications only, and not for use in any applications which may, directly or indirectly, cause death, personal injury, or severe property damages. In the event Macronix products are used in contradicted to their target usage above, the buyer shall take any and all actions to ensure said Macronix's product qualified for its actual use in accordance with the applicable laws and regulations; and Macronix as well as it's suppliers and/or distributors shall be released from any and all liability arisen therefrom.

Copyright© Macronix International Co., Ltd. 2018-2022. All rights reserved, including the trademarks and tradename thereof, such as Macronix, MXIC, MXIC Logo, MX Logo, Integrated Solutions Provider, Nbit, Macronix NBit, Hybrid-NVM, HybridFlash, HybridXFlash, XtraROM, KH Logo, BE-SONOS, KSMC, Kingtech, MXSMIO, RichBook, OctaBus, ArmorFlash, LybraFlash. The names and brands of third party referred thereto (if any) are for identification purposes only.

For the contact and order information, please visit Macronix's Web site at: <http://www.macronix.com>

**MACRONIX INTERNATIONAL CO., LTD.**

<http://www.macronix.com>

MACRONIX INTERNATIONAL CO., LTD. reserves the right to change product and specifications without notice.