



ITT

Electronic Components

Cannon SLC/SLE/CLC
APV Vector
Connectors



Engineered for life

Interconnect Technologies & Solutions for the Transportation Industry

For over 90 years, ITT has been developing innovative solutions for harsh environment applications. We have a proven track record of demonstrating our expertise and commitment to the transportation industry, offering the broadest portfolio of interconnect products.

Off-Road / Heavy Vehicle

Our interconnect range include sealed circulars, plastic and metal shell bayonet coupling circulars, miniature metal shell circulars, PC board header connectors and sensor and direct device connectors. ITT is also a systems supplier, providing value-added module and harness assemblies.

**In addition to our SLC/SLE/CLC/APV Vector series,
we also offer these connectivity solutions:**



Cannon APD

In-line and bulkhead sensors resistant to harsh environmental conditions (contaminants, vibration and shock).



Cannon CA-Bayonet

Signal and power connectors with exceptional sealing against the ingress of fluids and will withstand the effects of high vibrations.



Cannon Trident

Versatile range of electrical connectors based on a standard contact design. Options include; industrial grade, harsh environment and shielded circulars.

Multifunction Grips

Wide range of multifunction grip products that can be customized to meet your exact ergonomic and control needs.



The ITT "Engineered Blocks" symbol and the composite ITT logo are registered trademarks of ITT Industries. © 2005

Cannon SLC/SLE/CLC/APV Vector

Snap/Clip-Lock Environmental Sealed - Circular SLC/SLC-T/CLC

Engineering Quick Reference Selection Guide - How to Order 4-5
 Introduction 6
 Contact Arrangement 7
 Connectors 8-13
 Contacts 14
 Hand Tools, Semi-Automatic Tooling 15-18
 Test Parameters 19

SLE - Snap Lock Environmental Rectangular

Engineering Quick Reference Selection Guide - How to Order . . . 20-21
 Introduction 22
 Contact Arrangement, Polarization 23
 Connectors 24-27
 Contacts, Stamped 28
 Hand Tools, Semi-Automatic Tooling 29-32
 Test Parameters 33

APV Vector



Introduction 34
 Connectors 35
 Product Safety Information 36



Product Feature	SLE	SLC	SLC-T	Feed-Thru	CLC	APV Vector
Submersible	Yes	Yes	Yes	Yes	Yes	Yes
Splash Resistant	Yes	Yes	Yes	Yes	Yes	Yes
Snap Lock/No of Latch	Yes / 2	Yes / 2	Yes / 2	Yes / 1	Yes	Yes / 2
Hard Body	Yes	Yes	Yes	Yes	Yes	Yes
In-Line	Yes	Yes	Yes	Yes	Yes	Yes
Bulkhead Mount	Yes	Yes	Yes	Yes	Yes	Yes
PC Mount/Header	Yes	Yes	Yes	No	No	No
Stamped Rem. Cont.	Yes	Yes	Yes	Yes	Yes	Yes
Hand Insertable	Yes	Yes	Yes	Yes	Yes	Yes
Operating Temperature	-40°C to +150°C	-40°C to +150°C	-40°C to +150°C	-40°C to +150°C	-40°C to +150°C	-40°C to +150°C
Current Rating	6A/13A	6A/13A	6A/13A	6A	6A/13A	13A/25A
Adaptable for Sensors	No	Yes	Yes	Yes	Yes	Yes
Possibility of Mismatching	Very Low	Very Low	Very Low	Very Low	Very Low	Very Low
Susceptibility to Damage	Very Low	Very Low	Very Low	Very Low	Very Low	Very Low
Probability of Unmating in use	Very Low	Very Low	Very Low	Very Low	Very Low	Low
Connector Sealing Method	O Ring Cp	Interfacial	Interfacial	O Ring Cp	O Ring Cp	O Ring Cp
Wire Sealing Method	Grommet	Grommet	Grommet	Grommet	Grommet	Ind Wire Sl
Positive Polarization	Yes	Yes	Yes	Yes	Yes	Yes
Low Level Signal Performance	Yes	Yes	Yes	Yes	Yes	Yes
Secondary Lock	Not Reqd.	Not Reqd.	Not Reqd.	Not Reqd.	Yes	Yes
Automated Contact Insertion	Possible	Possible	Possible	Possible	Yes	Possible
Availability of Power Contacts	Yes	Yes	Yes	No	No	Yes
Connector Mating Force	Medium	Low	Low	Low	Low	Low
Contact Style	Pin / Skt.	Pin / Skt.	Pin / Skt.	Pin / Skt.	Pin / Skt.	Pin / Skt.
Contact Finish	Au	Au	Au	Ni / Au	Au	Au
Contact Density	High	High	High	Low	High	Low
Available Layouts	19, 28	5, 8, 10, 15	5, 8, 10, 15	2	a 2-3-4	2p, 2s

Snap/Clip-Lock Environmentally Sealed - Circular

Engineering Quick Reference Selection Guide

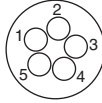
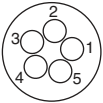
	2 Position		4 Position	5 Position	
Contact Arrangement	Plug 	Receptacle 	Contact Cannon	Plug 	Receptacle 
Features	Inline	Feed Thru	Inline	PCB	Inline
	Clip Lock	Clip Lock	Clip Lock	Snap Lock	Snap Lock
Specifications	CS-216	CS-216	CS-216	CS-206	CS-206
Plug	086-0066-000 w/Wedgelock 086-0058-000 Standard	086-0058-000 Standard	Contact Cannon	098532-0000 (5 A) 098532-001 (13 A)	098532-0000 (5 A) 098532-001 (13 A)
Receptacle	086-0061-000 w/Wedgelock	083-0242-000	Contact Cannon	098531-0000 (5 A) 098531-0001 (13 A)	098530-0000 (5 A) 098530-0001 (13 A)
Terminals	See page 14	See page 14	Contact Cannon	See page 14	See page 14

How to Order

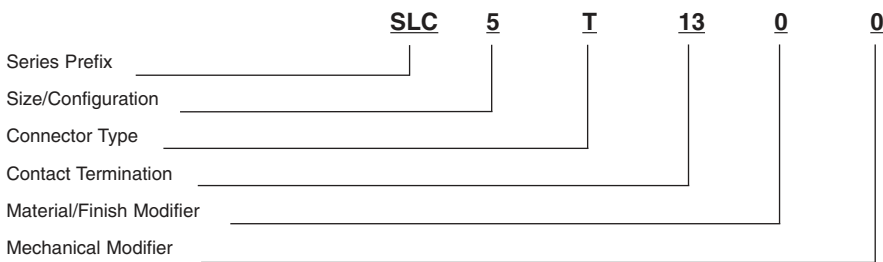

Series Prefix
SLC - Snap-Lock Circular

Size/Configuration
5-5 Cavity Housing
8-8 Cavity Housing
10-10 Cavity Housing
15-15 Cavity Housing

Connector Type
P - Plug, In-line (Cable-to-Cable)*
R - Receptacle, In-line (Cable-to-Cable)
T - Receptacle, Snap-thru
B - Receptacle, PCB

Contact Termination
5 - 5 A
13 - 13 A

Material/Finish Modifier
0 - Standard Assembly (Silicone Elastomer)
1 - Fluorosilicone Elastomer

Mechanical Modifier
0 - Standard Assembly

*Note: In-line Plug mates with all 3 receptacle types (In-line, Snap-thru, and PCB.)



Dimensions shown in mm
Specifications and dimensions subject to change

www.ittcannon.com

Snap/Clip-Lock Environmentally Sealed - Circular

Engineering Quick Reference Selection Guide

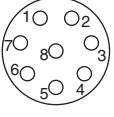
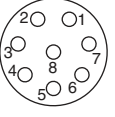
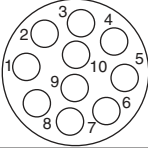
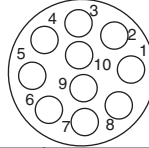
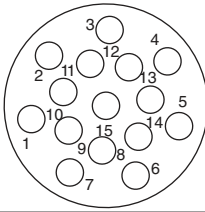
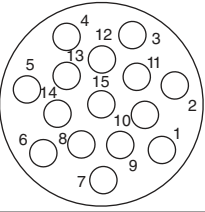
8 Position			10 Position			15 Position		
Plug		Receptacle	Plug		Receptacle	Plug		Receptacle
								
PCB	Inline	Snap-thru	PCB	Inline	Snap-thru	Snap-thru		
Snap Lock (Double)	Snap Lock (Double)	Snap Lock (Double)	Snap Lock (Double)	Snap Lock (Double)	Snap Lock (Double)	Snap Lock (Double)		
CS-210	CS-210	CS-210	CS-206	CS-206	CS-210		CS-210	
098532-0010	098532-0008	098532-0010	098532-0002 (5 A) 098532-0003 (13 A)	098532-0002 (5 A) 098532-0003 (13 A)	098532-0002 (5 A) 098532-0003 (13 A)		086-0060-000	
-	-	098533-0010	098531-0002 (5 A) 098531-0003 (13 A)	098530-0002 (5 A) 098530-0003 (13 A)	098533-0002 098533-0003		086-0059-000	
See page 14	See page 14	See page 14	See page 14	See page 14	See page 14	See page 14		

Dimensions shown in mm
 Specifications and dimensions subject to change

The Snap Lock Environmental Series is environmentally sealed connector created for printed circuit board, black box, cable-to-cable or bulkhead applications.

When your under-the-hood requirements call for tough performance, the SLC "snaps" into a tightly sealed connection that can withstand heat, shock and vibration. The connector is designed to preserve the integrity of the solid state package, while protecting against contaminants - even when unmated.

Gold, tin/lead plated stamped contacts add durability. A rugged, thermoplastic receptacle body maximizes performance by withstanding temperature variances from -40°C to +150°C (material rating).

The SLC series is available in 2, 5, 8, 10, 15 contact cavity configurations. It can also be adapted to robotics assembly. Should you requirement demand higher density configurations, consult Customer Service.



Product Features and Benefits

- Superior environmental sealing
- Material rating: -40°C to +150°C continuous operation at rated current
- Available in sizes 2, 5, 8, 10, 15 contacts
- Crimp stamped gold, tin/lead plated contacts
- Hand insertable/removable contacts
- Current rating 5 A and 13 A versions
- Low millivolt drop
- Low contact resistance
- Small footprint on P.C. board and low profile
- Adaptable to robotics assembly
- Latch with tactile and audible feedback
- Increases durability and provides for minimum installation
- Low installed cost
- Requires less PCB space

Performance Specifications

Contact Resistance	10mΩ maximum
Insulation Resistance	20MΩ minimum (USCAR)
Current Rating	5 A signal continuous at 150°C all contacts, 2 position 13 A power continuous at 150°C all contacts, 5 position and 10 position only
Dielectric Withstanding Voltage	1000 Vrms AC at sea level
Applicable Cannon Specification	SLC (CS-206) SLCT 5 & 10 (210) SLCT8 (216) SLCT 15 (206)
Material Rating Operating Temperature	-40°C to +150°C
Crimp Contacts	Semi-automatic or hand crimpable or fully automatic
Wire Size	20 - 16 AWG
Wire Insulation Sealing Range	1,98 (.078) to 3,30 (.130) dia.
Contact Insertion	No tool required. Suitable for automation.
Contact Extraction	Rear Removable
Contact Retention	20 lbs. Minimum per contact
Wire Strip Length	5,59 (.220) to 5,33 (.210)

Materials and Finishes

Connector Housing	High temperature thermoplastic
Contacts	Copper alloy
Finish	Engaging area: Gold over nickel Crimp/P.C. tail area: Tin/lead over nickel - standard offering Tin/Lead over nickel - Option #2 all over
Environmental Seal	High temperature silicone elastomer



Contact Cavity Arrangements - Mating Face View

Plug



2 Way

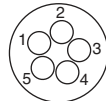

5 Way

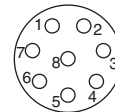

8 Way

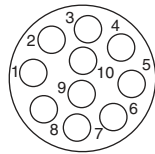

10 Way

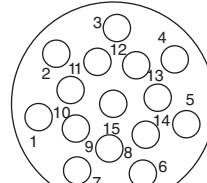

15 Way

Receptacle



2 Way

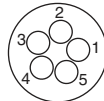

5 Way

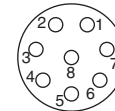

8 Way

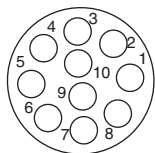

10 Way

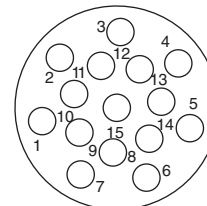

15 Way

Plug, In-line* (Cable-to-Cable) (Type P) SLC-5, SLC-10

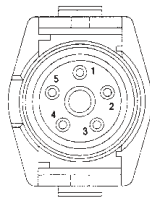
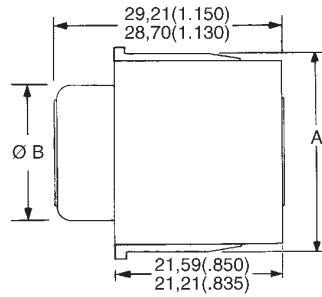

Front-Face View
5 Cavity Housing

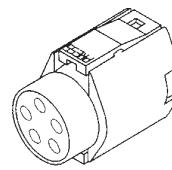

Side View
Plug Assembly

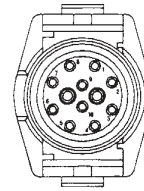

Front-Face View
10 Cavity Housing

In-line Plug* (Mates with SLC types R, T, and B)

Housing Size	Rating	Part Number	Description	A	ØB
5	5 A	098532-0011	SLC-5P5-00	27,81 (1.095)	18,03 (.710)
5	13 A	098532-0001	SLC-5P13-00	26,80 (1.055)	18,03 (.710)
10	5 A	098532-0002	SLC-10P5-00	34,92 (1.375)	24,15 (.990)
10	13 A	098532-0003	SLC-10P13-00	34,04 (1.340)	25,15 (.990)

*Contact lead assemblies are customer terminated and installed. See page 14, part numbers 110238-0488, 110238-2003.

Receptacle, In-line* (Cable-to-Cable) (Type R) SLC-5, SLC-10

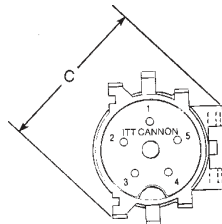
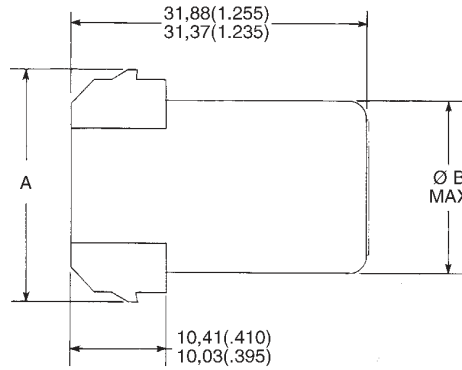

Front-Face View
5 Cavity Housing

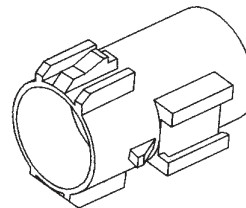

Side View
Receptacle Assembly

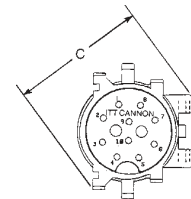

Front-Face View
10 Cavity Housing

In-line Receptacle* (Mates with SLC type P)

Housing Size	Rating	Part Number	Description	A	ØB	C Ref.
5	5 A	098530-0000	SLC-5R5-00	24,13 (.950)	18,03 (.710)	24,38 (.960)
5	13 A	098530-0001	SLC-5R13-00	23,75 (.935)	18,03 (.710)	24,38 (.960)
10	5 A	098530-0002	SLC-10R5-00	31,24 (1.230)	25,15 (.990)	31,62 (1.245)
10	13 A	098530-0003	SLC-10R13-00	30,86 (1.215)	25,15 (.990)	31,62 (1.245)

*Contact lead assemblies are customer terminated and installed. See page 16, part numbers 110238-0446, 110238-2004.

Square Flange



Snaps onto Type R and B connectors

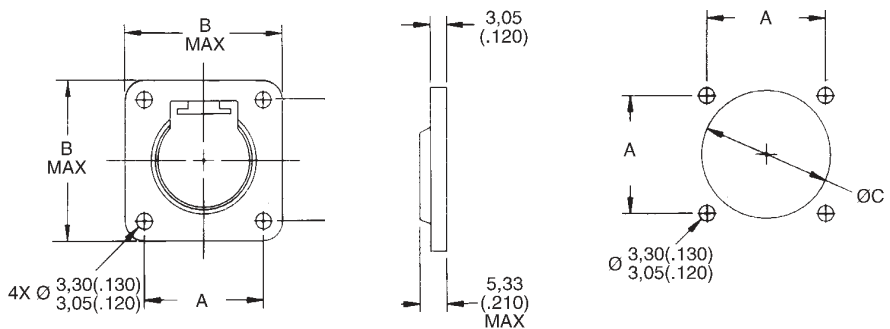

Materials and Finishes
Material: Thermoplastic
Color: Black

Housing Size	Part Number	A	B Max.	ØC
5	066-9504.000	23,37 (.920)	31,24 (1.230)	32,51 - 31,75 (1.280 - 1.250)
10	066-9504-001	28,45 (1.120)	36,32 (1.430)	25,40 - 24,64 (1.000 - .970)

Receptacle, Snap-thru* (Type T) SLC-5, SLC-10

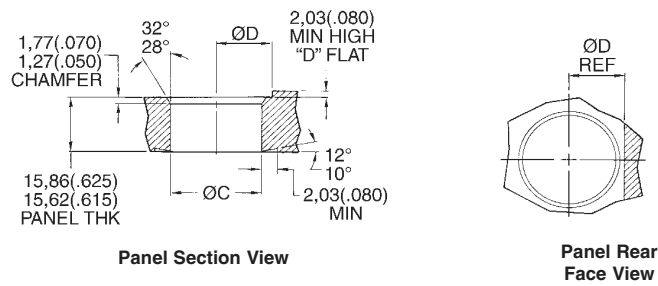
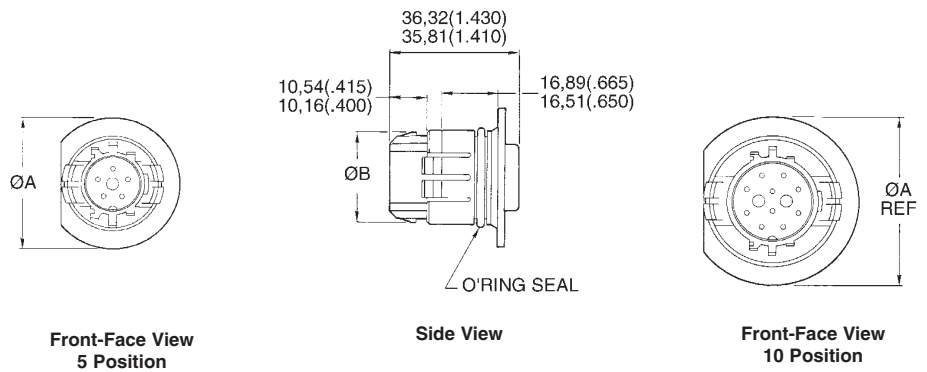

Snap-thru Receptacle* (Mates with SLC Type P)

Housing Size	Rating	Part Number	Description	ØA	ØB	ØC	ØD
5	5 A	098533-0000	SLC-5T5-00	37,21 (1.465)	24,13 (.950)	25,60 (1.008)	15,62 (.615)
5	13 A	098533-0001	SLC-5T13-00	36,96 (1.455)	23,75 (.935)	25,48 (1.003)	15,34 (.605)
10	5 A	098533-0002	SLC-10T5-00	47,62 (1.875)	31,24 (1.230)	35,05 (1.380)	20,19 (.795)
10	13 A	098533-0003	SLC-10T13-00	47,37 (1.865)	30,86 (1.215)	34,92 (1.375)	19,94 (.785)

*Contact lead assemblies are customer terminated and installed. See page 14, part numbers 110238-0446, 110238-2004.

Receptacle, PCB* (Type B) SLC-5, SLC-10

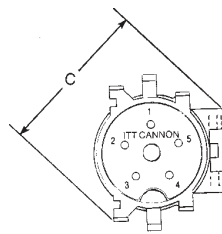
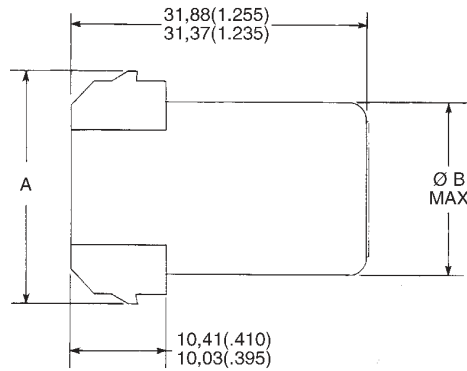

Front-Face View
5 Cavity Housing

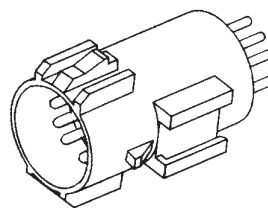

Side View
In-Line Receptacle
With PCB Contacts

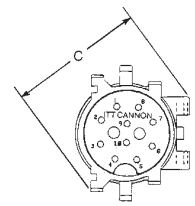

Front-Face View
10 Cavity Housing

In-line Receptacle* (Mates with SLC Type P)

Size	Rating	Part Number	Description	A	ØB	C Ref.
5	5 A	098531-0000	SLC-5B5-00	24,13 (.950)	18,03 (.710)	24,38 (.960)
5	13 A	098531-0001	SLC-5B13-00	23,75 (.935)	18,03 (.710)	24,38 (.960)
10	5 A	098531-0002	SLC-10B5-00	31,24 (1.230)	25,15 (.990)	31,62 (1.245)
10	13 A	098531-0003	SLC-10B13-00	30,86 (1.215)	25,15 (.990)	31,62 (1.245)

*PCB Contacts are factory installed.

Recommended PCB Layout

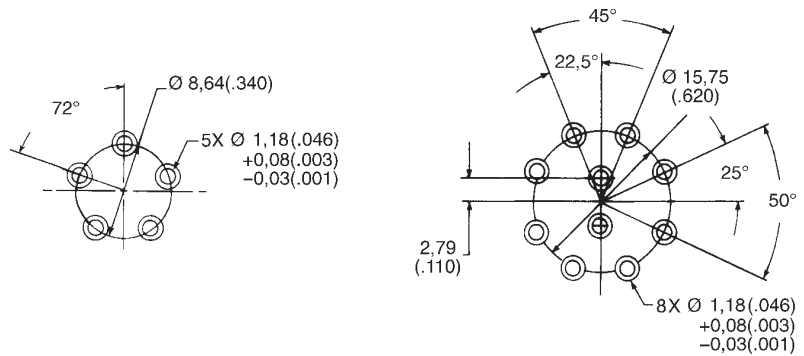

Receptacle, Snap-thru SLCT-8

Part No.: 098533-0010 (mates with 098532-0008)

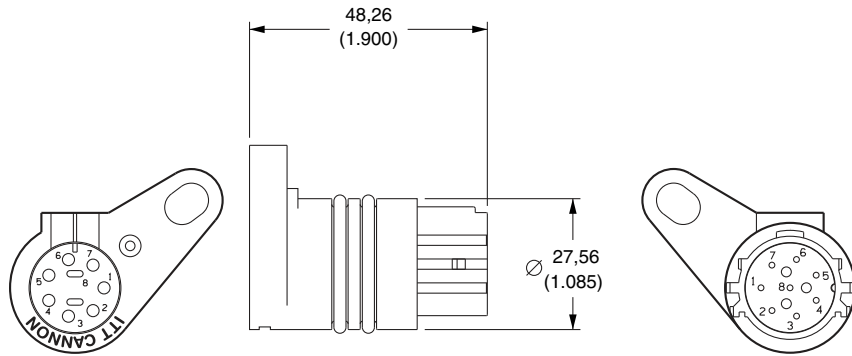

Receptacle, Feed-thru CLC-2

Part No.: 086-0057-000

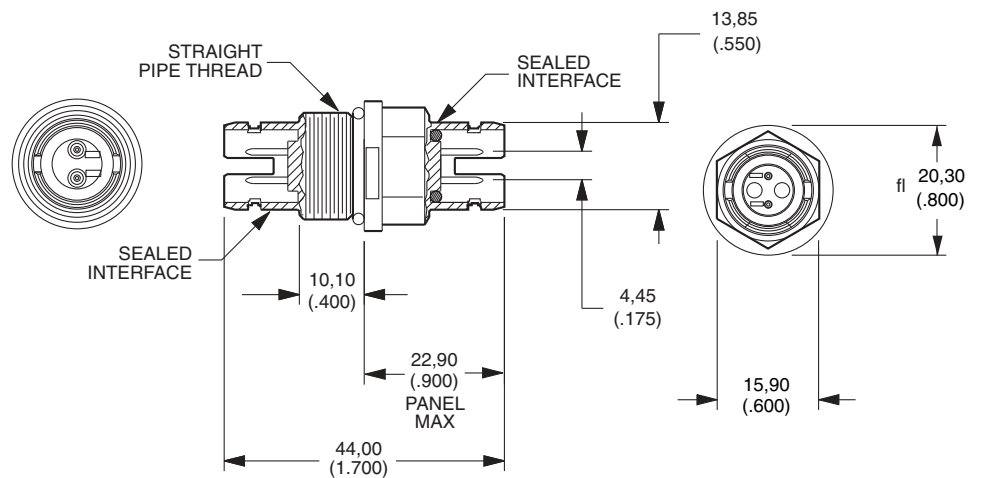

Note: In-line plug and receptacle available.

Plug, Feed-thru CLC-2

- Part No.: 086-0058-000
With Silicone Grommet Seal
- Part No.: 086-0058-001
With Silicone Grommet Seal
- Part No.: 086-0058-002
With Fluorosilicone Seal

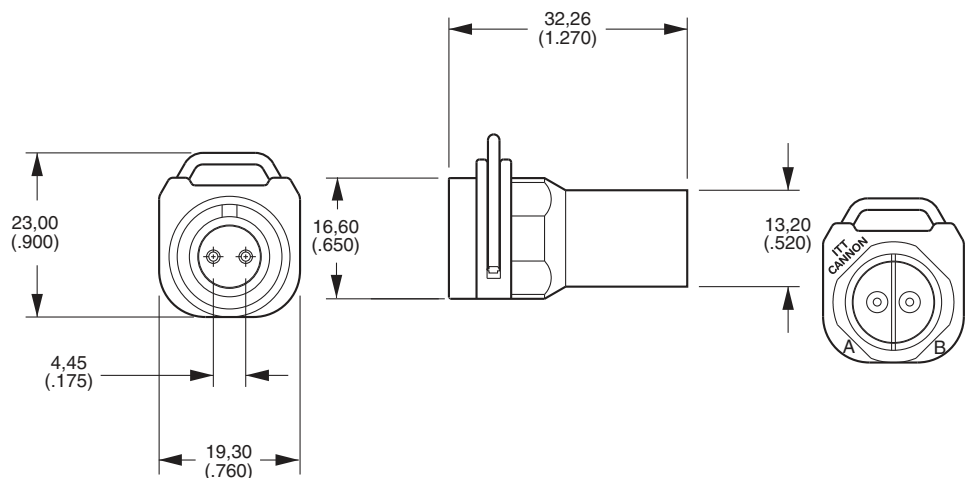

Right Angle CLC and CLC Y-Splice, please contact Product Management.



Dimensions shown in mm
Specifications and dimensions subject to change

www.ittcannon.com

Plug, Snap-thru SLC-15

Part Number: 086-0060-000

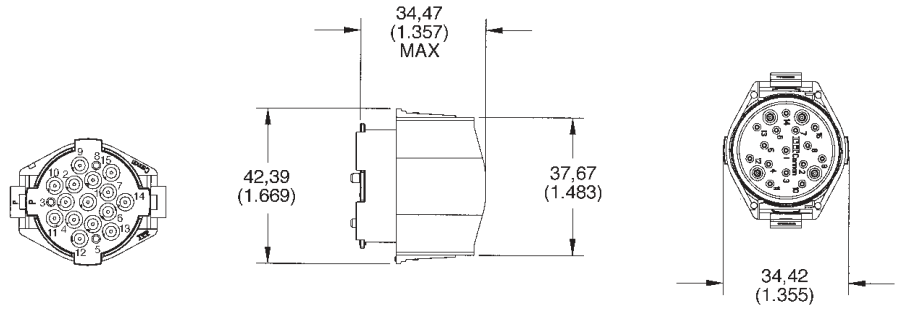

Receptacle, Snap-thru SLC-15

Part Number: 086-0059-000

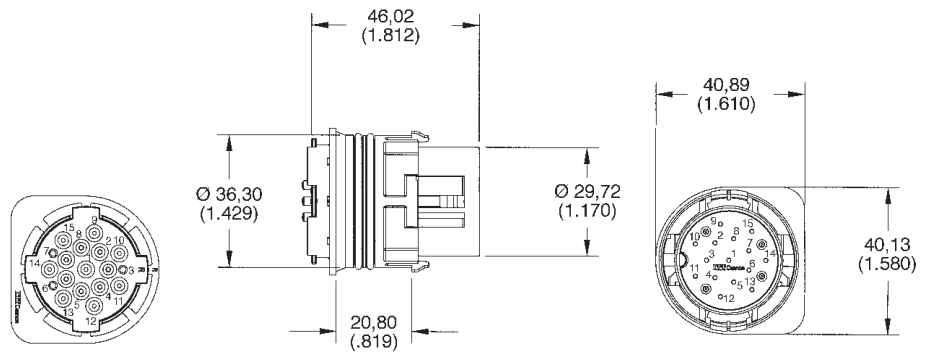

Consult factory for alternate layouts.

Contacts, Stamped, 5 and 13 Amp

Socket (use in plugs)

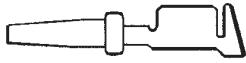

Hooded Socket

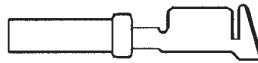

Pin (use in receptacles)

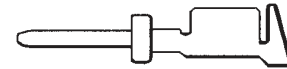

Description	Hooded Socket		Reeled	
	Socket Part Number	Pin Part Number	Socket Part Number	Number of Contacts
5 A	110238-1016 (030-2480-007)	110238-0446 (030-2464-007)	110238-0488 (030-2480-000)	4,500
13 A		110238-2004 (030-2464-003)	110238-2003 (030-2480-003)	4,000

Accessories

Sealing Plugs



Material: Thermoplastic, Color: Natural
 Part Number: 225-0093-000
 +125°C Rating

Connector Clip

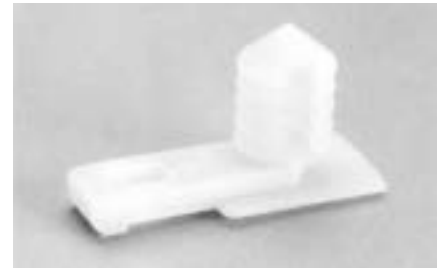

Material: Thermoplastic, Color: Natural
 Part Number: 225-0093-000
 +125°C Rating

Mounting Hardware for use on In-line Receptacle
 (Cable-to-Cable) (Type R)
 Fits Ø6,35 (.250) hole x 0,51 (.020) thick panel.

Extraction Tool

Contact Extraction Tool
 Part Number: 274-7068-001
 Tip Part Number: 323-9519-000



A Standard CET - SLE/SLC is available for extraction of the individual crimp contacts. Insertion tool is not required.

Insertion / Extraction Instructions for Crimp Contacts

Insertion Tool
 No insertion tool is required. The contact is easily snapped in from the rear of the connector manually.



1. Move to the rear of the connector so that the contact cavities can be identified.



2. Insert a crimp terminated assembly into a selected cavity.



3. Continue the forward movement until and audible snap can be felt and heard. Slight pull in the opposite direction will confirm complete insertion.

Extraction



1. Open the CET - SLC Extraction tool and place it over the insulation of the wire.



2. Using a straight motion forward, insert the tool along the wire until it bottoms against the connector. (Do not use a screwing motion - damage will result.)



3. While the extraction tool is in place, simply pull the wire/contact assembly out.



4. Remove the extraction tool. Extraction is complete.

Hand Crimp Tool Operation



Hand Crimp Tool - CCT - SLC / SLE
Part Number: 995-0002-232

The CCT-SLC/SLE hand crimp tool is designed to crimp individual SLC/SLE contacts on wire sizes 16, 18, and 20 AWG. Each cycle is ratchet-controlled (The tool must be completely closed before it can be reopened) to assure a satisfactory crimp each time. Over and under crimps are eliminated.

This tool is for use when the requirement is for low to moderate volume quantities, and for on-site applications where semi-automatic tools cannot be practically used.



1. Cycle the CCT - SLE / SLC hand tool to the open position.



2. While pressing upward on the locator spring, insert the contact with tails upward completely into the locator.



3. When correctly positioned the contact should be located beyond flush with the edge of the CCT - SLE / SLC and positioned in the concave polished split level crimp.



4. Partially (usually the first click) Cycle the hand tool assuring that the upward thrusting tails of the contact has started engaging with the top jaw of the tool. (There is a slight tendency for the contact to roll out of vertical alignment.)



5. Insert the pre-stripped wire into the crimp area of the contact and completely cycle the tool.



6. While pressing upward on the locator spring withdraw the crimp termination.



7. The result will be a perfect termination.



8. Note that there are no unterminated wire strands, and that some strand ends can be seen at the forward edge of the crimp. Also note the insulation is gripped by the smaller secondary crimp. Distortion is at a minimum, both axially and laterally - no sharp edges.

Wire Stripping

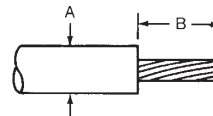

5 and 13 A Contact		
Tolerance	A	B
Low	2,41 (.095)	5,33 (.210)
High	3,30 (.130)	5,59 (.220)



Lease Automatic Tooling - North America*

ABT-607 Pneumatic Crimper



The ABT-607 is a pneumatic powered and controlled machine. It is designed for customers with moderate volume. This machine is designed to semi-automatically crimp stamped and formed contacts onto pre-stripped stranded or single conductor electrical wire. This machine will accommodate size 34 thru 12 AWG wire and is actuated by the use of a foot pedal.

Machine Crimp Rate:
800 per hour

Power Requirements:
Pneumatic = 100 psi, 2 cu. ft. per min.

ABT-500 UCCD

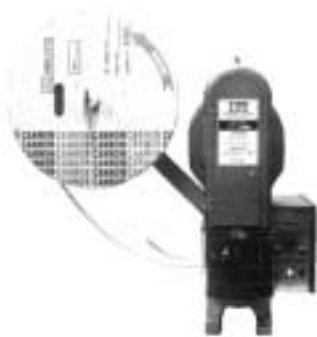

The ABT-500 Universal Cannon Crimp Die, is a flywheel driven, electronically controlled machine that is designed to semi-automatically crimp stamped and formed contacts on stranded or single conductor, pre-stripped wire. This machine will accommodate size 34 thru 12 WG wire. The machine is actuated by the use of a foot pedal.

Machine Crimp Rate:
1300 per hour

Power Requirements:
Electrical = 115VAC, 60Hz, 20A

ABT-620 UCCS



The ABT-620 Universal Cannon Crimper/Stripper is a pneumatic powered, microprocessor controlled machine. It is designed to semi-automatically strip insulation from stranded or single conductor electrical wire and attach a stamped and formed contact by crimping. The machine will accommodate 34 thru 12 AWG wire. Primary application of the machine is the termination of jacketed cable where the individual leads cannot be stripped by fully automated equipment. The ABT-620 UCCS operates automatically upon insertion of a wire or it can be switched over to foot pedal operation if desired.

Machine Crimp Rate:
1200+ per hour

Power Requirements:
Electrical = 115VAC, 60Hz, 20A
Pneumatic = 80 psi, 3 cu. ft. per min.

* For other geographical regions, contact Cannon for details.

Crimp Pot Cross Section

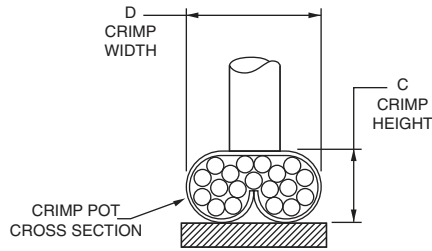

The wire crimp heights listed are only reference and valid for the correspondingly listed wire size, wire plating and wire stranding.

The wire crimp tensile values must be used to assure the performance of crimped contacts.

For wire crimp information not listed in this table, please contact Cannon.

Crimp Height and Width

	Wire Gauge (AWG)					
	16		18		20	
	C*	D Ref.	C*	D Ref.	C*	D Ref.
Signal (5A)	.064*	.082	.056*	.080	.054*	.080
Power (13A)	.066*	.082	.062*	.080	.058*	.080

* Hand Tools are ± .002 and machines are ± .001

Insulation Height and Width

	Wire Gauge (AWG)					
	16		18		20	
	Height	Width	Height	Width	Height	Width
	Max	Max**	Max	Max**	Max	Max**
Signal (5A)	.110	.115**	.105	.110**	.105	.110**
Power (13A)	.110	.115**	.105	.110**	.105	.110**

** Measurements are taken without crimping wire insulation.

Crimp Tensile Strength

Wire Trim Dimension



Wire Size (AWG)	16	18	20
Tensile Min (lbs)	35 lbs.	25 lbs.	20lbs.



Test Parameters





SLC Products are designed to meet Cannon specifications CS-206, CS-210, and CS-216. Items of most general interest to users are designers are listed below.

Test Description	Reference Paragraph	Requirements																																										
Environmental Sealing	3.2.3.5 3.2.3.6 3.2.3.7 3.2.3.8 3.2.3.9 3.2.3.2	Sand and Dust MIL-STD-202 Method 110 Test Condition A 5% salt spray 96 hours 10 cycles of 24 hours, 90-98% humidity Steam Cleaning/Pressure Wash 95°C, 375 Cycles 750 PSIG Solvent Resistance/Immersion (see 3.2.3.9) Thermal Shock 100 Cycles -40°C to +150°C ± 3°C																																										
Contact Crimp Tensile Strength	3.2.2.1	The minimum tensile load required to separate the wire from the contact, either by pulling the wire out of the crimp joint or by breaking the wire within the crimp joint shall not be less than the applicable limits as specified. Wire breakage or contact damage not due to crimping at less than tensile loads shall not constitute a failure. <table border="1" style="margin-left: auto; margin-right: auto;"> <thead> <tr> <th>Wire Size AWG</th> <th>Crimp Tensile Strength, Pounds Minimum</th> </tr> </thead> <tbody> <tr> <td>16</td> <td>35</td> </tr> <tr> <td>18</td> <td>25</td> </tr> <tr> <td>20</td> <td>20</td> </tr> </tbody> </table>	Wire Size AWG	Crimp Tensile Strength, Pounds Minimum	16	35	18	25	20	20																																		
Wire Size AWG	Crimp Tensile Strength, Pounds Minimum																																											
16	35																																											
18	25																																											
20	20																																											
Insulation Resistance	3.2.1.1	Mated and wired connectors shall exhibit an insulation resistance greater than 100 megohms between all contacts. This limit shall apply after exposure to each environment including salt solution immersion. Tests shall be performed at 100 VDC ± 10%.																																										
Dielectric Withstanding Voltage	3.2.1.2	Wired and mated connectors shall show no evidence of breakdown between adjacent contacts when tested at 1000 VDC ± 5%. Connectors shall meet this requirement after exposure to each environment. Current leakage shall be less than 1.0 milliamp.																																										
Low Level Contact Resistance	3.2.1.4	The low level contact resistance of mated contacts shall be less than 10 milliohms when measured across the contacts and crimp joints. The test current shall be a maximum of 100 milliamps with an open circuit test voltage of 20 millivolts maximum.																																										
Mechanical Shock	3.2.3.3	Connectors shall be subjected to three shocks in each direction applied along the three mutually perpendicular axes of the connector test specimen for a total of 12 shocks. Each shock shall consist of a terminal peak sawtooth pulse with a peak value of 100 g's and a duration of 6 milliseconds.																																										
Vibration	3.2.3.4	Connectors shall be subjected to random vibration in accordance with MIL-STD-1344, Method 2005.1, test condition VI for 20 hours along each of the following three axes: <table border="1" style="margin-left: auto; margin-right: auto;"> <thead> <tr> <th>Direction</th> <th>Grms</th> </tr> </thead> <tbody> <tr> <td>Radial axis of connector (Y)</td> <td>10.2</td> </tr> <tr> <td>Longitudinal axis of connector (Z)</td> <td>10.2</td> </tr> </tbody> </table> Electrical continuity of the connectors shall be monitored during the last 20 minutes sweep in each axis with a test current of 100 milliamps or less and a test voltage less than 2VDC. Electrical discontinuities in excess of 10 microseconds shall be cause of failure.	Direction	Grms	Radial axis of connector (Y)	10.2	Longitudinal axis of connector (Z)	10.2																																				
Direction	Grms																																											
Radial axis of connector (Y)	10.2																																											
Longitudinal axis of connector (Z)	10.2																																											
Durability	3.2.2.6	Connectors shall be subjected to 25 cycles of mating and unmating at room temperature. Following this test there shall be no evidence of damage to the contacts, contact plating, connector housing or seals which may prove detrimental to reliable performance of the connector.																																										
Contact	3.2.2.2	Contacts shall not be displaced greater than 0.030 inches from the connector body when a force of 10 pounds is applied. When this test follows maintenance again the same contacts shall be tested.																																										
Maintenance Aging	3.2.2.3	Consist of subjecting each wired receptacle to 5 cycles of removal and reinsertion of 20% of the contacts or a minimum of 5 per connector with approved tooling.																																										
Mating and Separating Force	3.2.2.4	The maximum force required to mate the plug and receptacle shall be 10 pounds. The maximum force required to separate the plug and receptacle shall be 5 pounds. The rate of travel shall be one inch per minute.																																										
Solvent Resistance Immersion	3.2.2.9	Connectors shall be subjected to the following fluids at the temperature and length of time specified. Following the fluid dip or immersion, the connectors shall be immersed to a depth of 2 to 12 inches in a 5% salt-water solution for 24 hours at room temperature. At the completion of the salt-water immersion test, while still immersed, the connectors shall meet the insulation resistance requirement specified herein. <table border="1" style="margin-left: auto; margin-right: auto;"> <thead> <tr> <th>Fluid</th> <th>Method</th> <th>Temperature</th> </tr> </thead> <tbody> <tr> <td>No. 2 Diesel Fluid</td> <td>Immersion (2)</td> <td>140°F</td> </tr> <tr> <td>Methyl Alcohol</td> <td>Dip (1)</td> <td>Room Temperature</td> </tr> <tr> <td>Antifreeze</td> <td></td> <td></td> </tr> <tr> <td>- Prestone</td> <td>Immersion (2)</td> <td>180°F</td> </tr> <tr> <td>- 50% Water/50%</td> <td>Immersion (2)</td> <td>180°F</td> </tr> <tr> <td>Ethylene Glycol</td> <td></td> <td></td> </tr> <tr> <td>Degreaser</td> <td></td> <td></td> </tr> <tr> <td>- Gunk</td> <td>Dip (1)</td> <td>Room Temperature</td> </tr> <tr> <td>- Mineral Spirits</td> <td>Dip (1)</td> <td>Room Temperature</td> </tr> <tr> <td>Paint (Oil Base)</td> <td>Immersion (2)</td> <td>Room Temperature</td> </tr> <tr> <td>Lubricating Oil (SAE 10 W40)</td> <td>Immersion (2)</td> <td>200°F</td> </tr> <tr> <td>Brake Fluid (Delco Supreme)</td> <td>Dip (1)</td> <td>Room Temperature</td> </tr> <tr> <td>Transmission Fluid fully submerged and pressurized @ 7 psi. (Dextron)</td> <td>Dip (1)</td> <td>Room Temperature</td> </tr> </tbody> </table> (1) Dip: Connectors shall withstand a one second dip and a three minute air dry for a total of 80 cycles. (2) Immersion: Connectors shall withstand immersion for one hour.	Fluid	Method	Temperature	No. 2 Diesel Fluid	Immersion (2)	140°F	Methyl Alcohol	Dip (1)	Room Temperature	Antifreeze			- Prestone	Immersion (2)	180°F	- 50% Water/50%	Immersion (2)	180°F	Ethylene Glycol			Degreaser			- Gunk	Dip (1)	Room Temperature	- Mineral Spirits	Dip (1)	Room Temperature	Paint (Oil Base)	Immersion (2)	Room Temperature	Lubricating Oil (SAE 10 W40)	Immersion (2)	200°F	Brake Fluid (Delco Supreme)	Dip (1)	Room Temperature	Transmission Fluid fully submerged and pressurized @ 7 psi. (Dextron)	Dip (1)	Room Temperature
Fluid	Method	Temperature																																										
No. 2 Diesel Fluid	Immersion (2)	140°F																																										
Methyl Alcohol	Dip (1)	Room Temperature																																										
Antifreeze																																												
- Prestone	Immersion (2)	180°F																																										
- 50% Water/50%	Immersion (2)	180°F																																										
Ethylene Glycol																																												
Degreaser																																												
- Gunk	Dip (1)	Room Temperature																																										
- Mineral Spirits	Dip (1)	Room Temperature																																										
Paint (Oil Base)	Immersion (2)	Room Temperature																																										
Lubricating Oil (SAE 10 W40)	Immersion (2)	200°F																																										
Brake Fluid (Delco Supreme)	Dip (1)	Room Temperature																																										
Transmission Fluid fully submerged and pressurized @ 7 psi. (Dextron)	Dip (1)	Room Temperature																																										
Temperature Life	3.2.3.1	Connectors shall be subjected to a temperature of 150°C ± 3°C for a period of 1000 hours. At the end of the temperature soak period and after removal from the chamber, the connectors shall meet the insulation resistance and dielectric withstanding voltage requirements specified herein. Connectors shall be operated at rated current throughout the duration of the temperature life test. Upon removal from the chamber at the conclusion of the test, the connectors shall show no visual signs of damage, which may be detrimental to the performance of the connector.																																										
Thermal Cycling	3.2.3.2	Connectors shall be subjected to 100 thermal cycles from -40°C to +150°C. One cycle shall consist of the transitions from room temperature to -40°C to +150°C, and from 150°C to room temperature. One cycle shall be accomplished in a three-hour period with a minimum stabilization period of 15 minutes at each temperature extreme. The chamber temperature transition rate shall be a minimum of 1.30°C per minute and a maximum of 6.00°C per minute.																																										

Specifications and dimensions subject to change

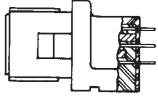

Engineering Quick Reference Selection Guide

Part No. Description		Contact Arrangement	No. of Contacts	Plug, Straight PCB	
19 Position	28 Position			19 Position	28 Position
					
				For PCB Layout, see page 24.	
SLEB19P4S SLEB19P4D SLEB19P4L SLEB19P4SG SLEB19P4R SLEB19P4UG SLEB19P4U SLEB19P4DG			19		
SLEB19S2SF SLEB19S2R SLEB19S2S SLEB19S2U SLEB19S2L SLEB19S2D					
SLEB19N3P SLEB19N3PN SLEB19N3PM SLEB19N3					
SLEB19T3P SLEB19T3 SLEB19T3PM SLEB19T3H SLEB19T3PN				130415-0000 130415-0004 130415-0001 130415-0005 130415-0002	
	SLEC28P4S SLEC28P4D SLEC28P4L SLEC28P4SG SLEC28P4R SLEC28P4UG SLEC28P4U SLEC28P4DG		28		
	SLEC28S2SF SLEC28S2R SLEC28S2S SLEC28S2U SLEC28S2L SLEC28S2D				
	SLEC28N3P SLEC28N3PN SLEC28N3PM SLEC28N3				
	SLEC28T3P SLEC28T3PE SLEC28T3PM SLEC28T3 SLEC28T3PN				130415-0000 130415-0004 130415-0001 130415-0005 130415-0002
SLEB130411 SLEB19S12 SLEB130411 SLEB19S14			19		
	SLEC130415 SLEC28S12 SLEC130414 SLEC28S14		28		



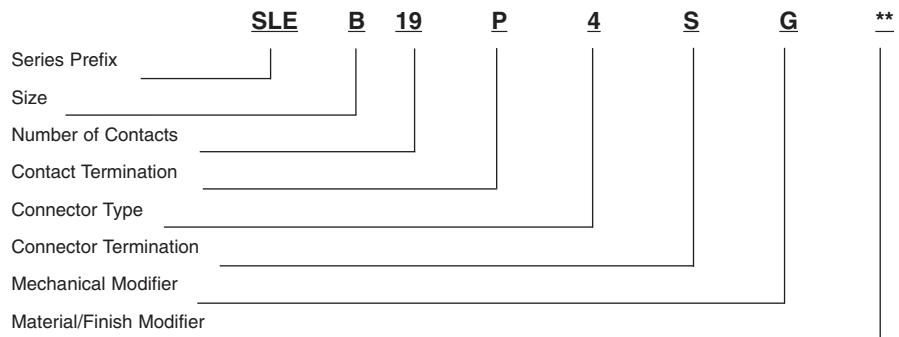

How to Order

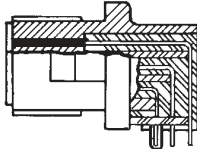
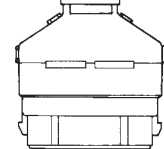

Dimensions shown in mm
Specifications and dimensions subject to change

www.ittcannon.com

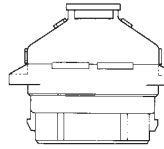
Engineering Quick Reference Selection Guide

Plug, 90° PCB 19 Position 28 Position		Plug, In-line 19 Position 28 Position		Receptacle, In-line 19 Position 28 Position	
					
For PCB Layout, see page 25					
				130408-0000 130408-0004 130408-0001 130408-0010 130408-0002 130408-0011 130408-0003 130408-0012	
		130413-0000 130413-0003 130413-0001 130413-0004 130413-0002 130413-0005			
130414-0000 130414-0002 130414-0001 130414-0004					
					130412-0000 130412-0004 130412-0001 130412-0010 130412-0002 130412-0011 130412-0003 130412-0012
			130413-0000 130413-0003 130413-0001 130413-0004 130413-0002 130413-0005		
	130414-0000 130414-0002 130414-0001 130414-0004				
Note: For configuration contact Cannon.					
Note: For configuration contact Cannon.					

Series Prefix
SLE - SLE-Snap Lock Environmental

Size
B-19 Cavity Housing
C-28 Cavity Housing

Number of Contacts
19 or 28

Contact Termination
T - Tuning Fork Straight [Plug with 3,05 (.120) min. PCB tails]
N - Tuning Fork 90° [Plug with 2,54 (.100) min. PCB tails]
P - Crimp Pin (Receptacle)
S - Crimp Socket (Plug)
P1 - Crimp Pin Power (Receptacle)
S1 - Crimp Socket Power (Pin)

Connector Type
2 - Plug, In-line (Cable-to-Cable)
3 - Plug, PCB
4 - Receptacle, In-line (Cable-to-Cable)

Connector Termination
S - Straight (Endbell)
L - 90° Left (Endbell)
R - 90° Right (Endbell)
U - 90° Up (Endbell)
D - 90° Down (Endbell)
P - Potted (PCB Only)

Mechanical Modifier
F - With Flange Mount (Plug only)
G - Screwlock Applications (Receptacle only)
M - Metric Threaded Inserts
N - Threaded Inserts #6-32
E - Threaded Inserts #6-32

The Snap Lock Environmental Series is environmentally-sealed connector created for printed circuit board, blackbox, cable-to-cable, or bulkhead applications.

When your under-the-hood requirements call for tough performance, the SLE "snaps" into a tightly sealed connection that can withstand heat, shock and vibration. The connector is designed to preserve the integrity of the solid state package, while protecting against contaminants - even when unmated.

Polarization, scoop-proofing and hand insertion of contacts are part of the package. Gold, tin/lead-plated stamped contacts add durability. A rugged, thermoplastic receptacle body maximizes performance by withstanding temperature variances from -40°C to +125°C.

The SLE series is available in both 19 and 28 contact cavity configurations. It can also be adapted to robotic assembly. Should your requirement demand higher density configurations, consult Customer Service.



Product Feature and Benefits

- Superior environmental sealing
- -40°C to +125°C continuous operation at rated current
- Available in two sizes, 19 and 28 contacts
- Crimp stamped gold, tin/lead plated contacts
- Hand insertable/removable contacts
- Current rating 5 A and 13 A versions
- Low millivolt drop
- Small footprint on P.C. board and low profile
- 5-way alternate polarization
- Integral mold latch. Adaptable to robotic assembly.
- Multi-direction, easily assembled endbells
- Optional secondary bail latch
- Latch with tactile and audible feedback
- Low installed cost
- Meets both signal and power requirements
- Versatile cable strain relief, up, down, straight, left ad right, flange/bulkhead
- Connector mating assurance

Performance Specifications

Contact Resistance	10 mΩ maximum
Insulation Resistance	100 MΩ minimum
Current Rating	5 A signal continuous at 125°C all contacts 13 A power continuous at 125°C all contacts
Dielectric Withstanding Voltage	1000 Vrms AC at sea level
Applicable Cannon Specification	CS-189
Operating Temperature	-40°C to +125°C
Crimp Contacts	Semi-automatic or hand crimpable
Wire Size	20-16 AWG
Wire Insulations Sealing Range	2,41 (.095) to 3,30 (.130) dia.
Polarization	'D' shaped interface with five alternate positions.
Contact Insertion	No tool required. Suitable for automation.
Contact Extraction	Rear removable
Contact Retention	25 lbs. Minimum per contact
Wire Strip Length	5,59 (.220) to 5,33 (.210)

Materials and Finishes

Connector Housing	High temperature thermoplastic
Contacts	Copper alloy
Finish	Engaging area: Gold over nickel Crimp/P.C. tail area: Tin/lead over nickel
Environmental Seal	High temperature silicone elastomer

Contact Cavity Arrangement

Face View - Engaging Face of Plug

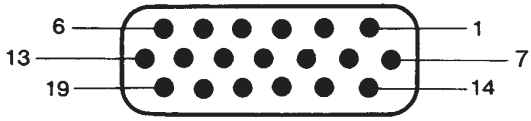

Size B
19 Contacts

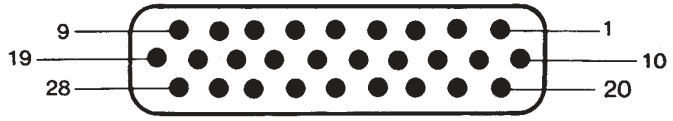

Size C
28 Contacts

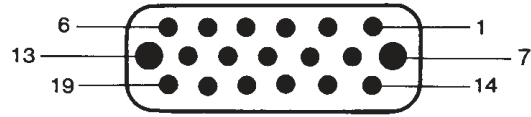

Power Version*

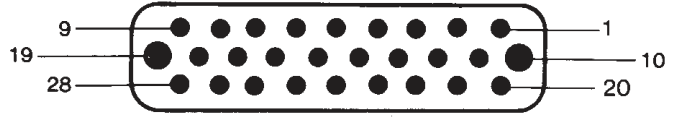

Power Version*

*Contact Cannon

Polarization

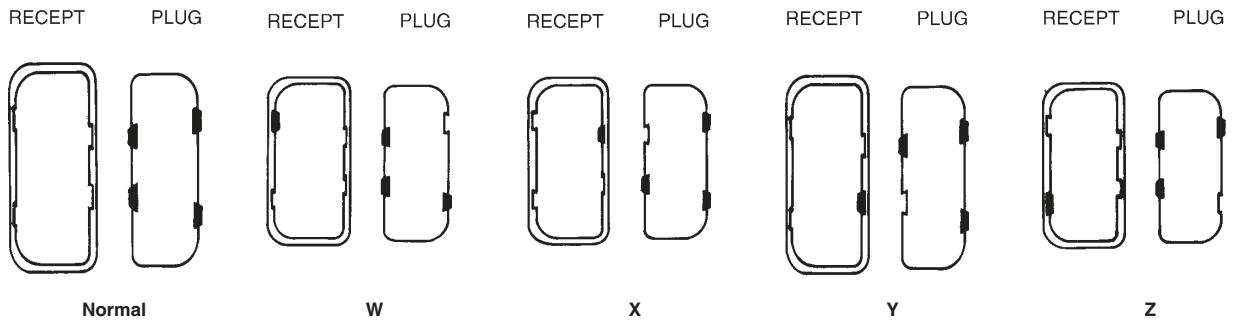

Endbells

Connectors are supplied with endbell assemblies.

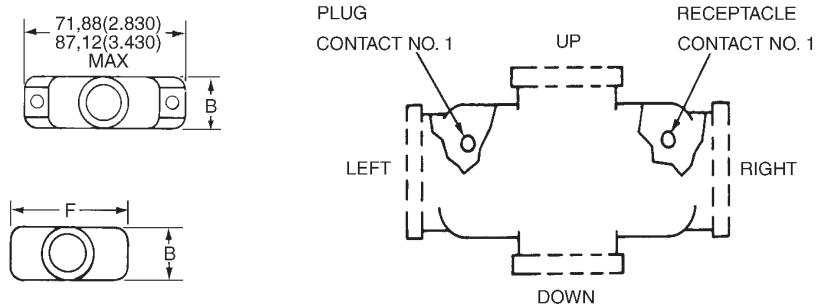

Part number by Shell Size	B Max.	F Max.	Cable Entry I.D.
SLEB	26,16 (1.030)	50,80 (2.000)	14,73 (.580)
SLEC	26,16 (1.030)	66,04 (2.600)	19,81 (.780)

Plug, In-line (Cable-to-Cable)

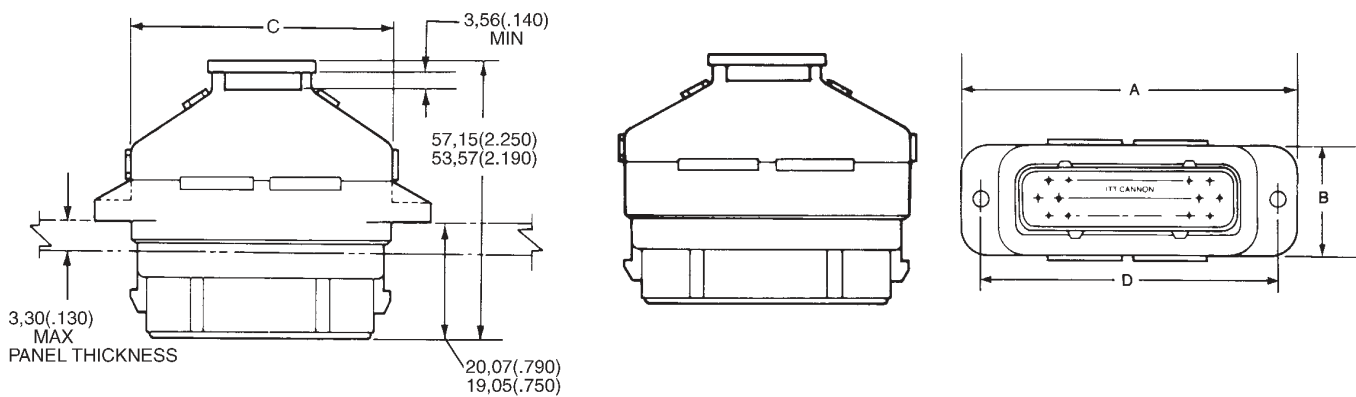

With Flange Endbell (Plug Only)

Note: Plugs are supplied with endbell assemblies.

Shell Size	Number of Contacts	Part Number*	Nomenclature	A Max.	C Max.	D ±0,38 (.015)
SLEB	19	130409-0000*	SLEB19S2SF	71,88 (2.830)	47,50 (1.870)	59,05 (2.325)
SLEB	19	130409-0001*	SLEB19S2S	71,88 (2.830)	47,50 (1.870)	59,05 (2.325)
SLEB	19	130409-0002*	SLEB19S2L	71,88 (2.830)	47,50 (1.870)	59,05 (2.325)
SLEB	19	130409-0003*	SLEB19S2R	71,88 (2.830)	47,50 (1.870)	59,05 (2.325)
SLEB	19	130409-0004*	SLEB19S2U	71,88 (2.830)	47,50 (1.870)	59,05 (2.325)
SLEB	19	130409-0005*	SLEB19S2D	71,88 (2.830)	47,50 (1.870)	59,05 (2.325)
SLEC	28	130413-0000	SLEC28S2SF	87,11 (3.430)	62,74 (2.470)	74,29 (2.925)
SLEC	28	130413-0001	SLEC28S2S	87,11 (3.430)	62,74 (2.470)	74,29 (2.925)
SLEC	28	130413-0002	SLEC28S2L	87,11 (3.430)	62,74 (2.470)	74,29 (2.925)
SLEC	28	130413-0003	SLEC28S2R	87,11 (3.430)	62,74 (2.470)	74,29 (2.925)
SLEC	28	130413-0004	SLEC28S2U	87,11 (3.430)	62,74 (2.470)	74,29 (2.925)
SLEC	28	130413-0005	SLEC28S2D	87,11 (3.430)	62,74 (2.470)	74,29 (2.925)

*Select polarization, see page 25.



Receptacle, In-line (Cable-to-Cable)

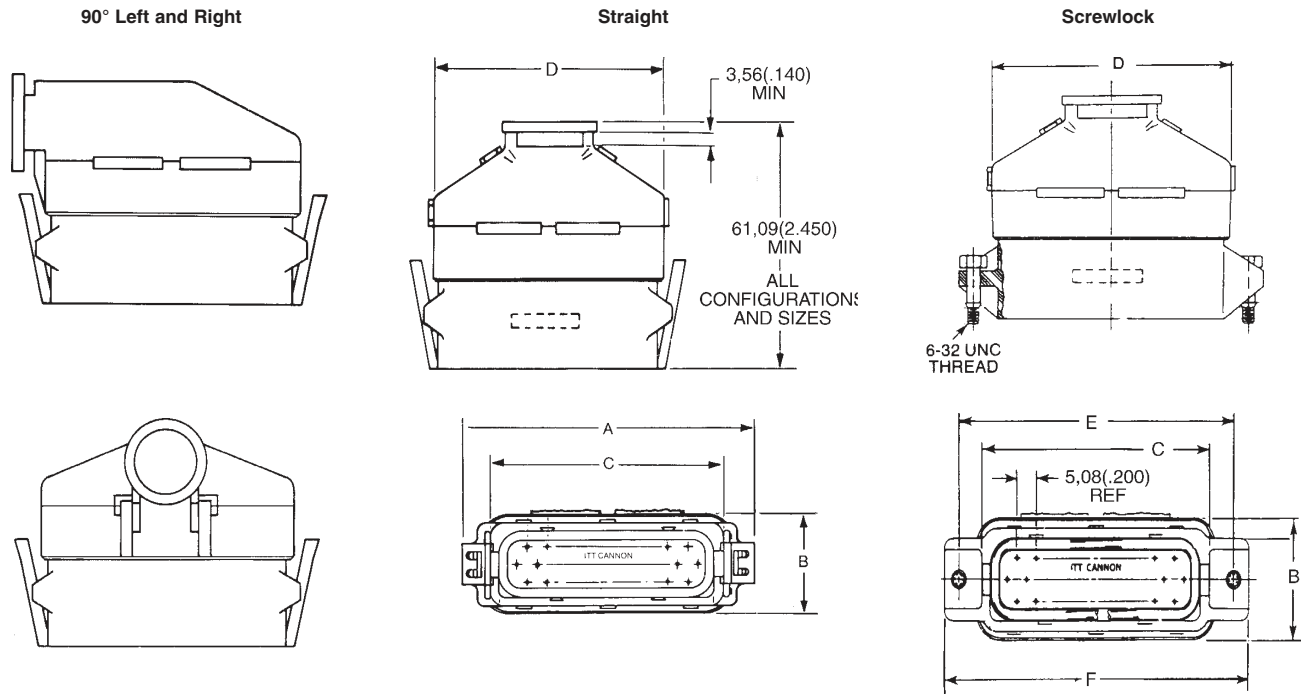

Note: Receptacles are supplied with endbell assemblies.

Shell Size	Number of Contacts	Part Number*	Nomenclature	A Max.	C Max.	D Max.	±0,38 (.015)	E F Max.
SLEB	19	130408-0000*	SLEB19P4S	59,44 (2.340)	44,07 (1.735)	50,58 (2.000)	55,87 (2.200)	64,25 (2.530)
SLEB	19	130408-0001*	SLEB19P4L	59,44 (2.340)	44,07 (1.735)	50,58 (2.000)	55,87 (2.200)	64,25 (2.530)
SLEB	19	130408-0002*	SLEB19P4R	59,44 (2.340)	44,07 (1.735)	50,58 (2.000)	55,87 (2.200)	64,25 (2.530)
SLEB	19	130408-0003*	SLEB19P4U	59,44 (2.340)	44,07 (1.735)	50,58 (2.000)	55,87 (2.200)	64,25 (2.530)
SLEB	19	130408-0004*	SLEB19P4D	59,44 (2.340)	44,07 (1.735)	50,58 (2.000)	55,87 (2.200)	64,25 (2.530)
SLEB	19	130408-0010*	SLEB19P4SG	59,44 (2.340)	44,07 (1.735)	50,58 (2.000)	55,87 (2.200)	64,25 (2.530)
SLEB	19	130408-0011*	SLEB19P4UG	59,44 (2.340)	44,07 (1.735)	50,58 (2.000)	55,87 (2.200)	64,25 (2.530)
SLEB	19	130408-0012*	SLEB19P4DG	59,44 (2.340)	44,07 (1.735)	50,58 (2.000)	55,87 (2.200)	64,25 (2.530)
SLEC	28	130412-0000	SLEC28P4S	76,45 (3.010)	59,31 (2.335)	66,04 (2.600)	71,11 (2.800)	79,49 (3.130)
SLEC	28	130412-0001	SLEC28P4L	76,45 (3.010)	59,31 (2.335)	66,04 (2.600)	71,11 (2.800)	79,49 (3.130)
SLEC	28	130412-0002	SLEC28P4R	76,45 (3.010)	59,31 (2.335)	66,04 (2.600)	71,11 (2.800)	79,49 (3.130)
SLEC	28	130412-0003	SLEC28P4U	76,45 (3.010)	59,31 (2.335)	66,04 (2.600)	71,11 (2.800)	79,49 (3.130)
SLEC	28	130412-0004	SLEC28P4D	76,45 (3.010)	59,31 (2.335)	66,04 (2.600)	71,11 (2.800)	79,49 (3.130)
SLEC	28	130412-0010	SLEC28P4SG	76,45 (3.010)	59,31 (2.335)	66,04 (2.600)	71,11 (2.800)	79,49 (3.130)
SLEC	28	130412-0011	SLEC28P4UG	76,45 (3.010)	59,31 (2.335)	66,04 (2.600)	71,11 (2.800)	79,49 (3.130)
SLEC	28	130412-0012	SLEC28P4DG	76,45 (3.010)	59,31 (2.335)	66,04 (2.600)	71,11 (2.800)	79,49 (3.130)

*Select polarization, see page 23.

Plug, PCB, Straight

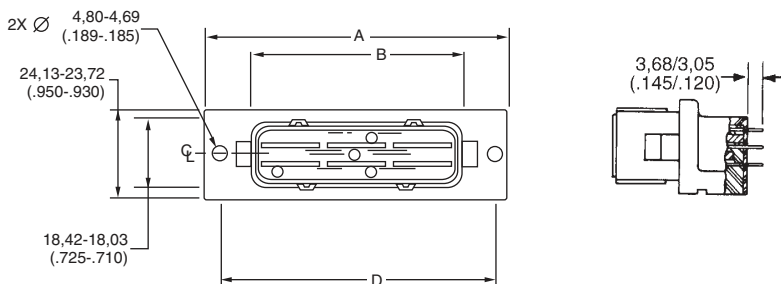

Panel Cutout

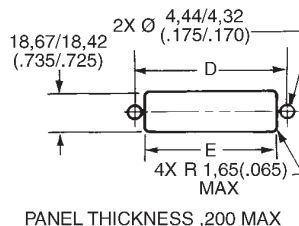

PANEL THICKNESS .200 MAX

Shell Size	Number of Contacts	Part Number*	Nomenclature	A Max.	B Max.	D Max.	E Max.
SLEB	19	130411-0000*	SLEB19T3P	63,50 (2.500)	74,94 (3.100)	56,13 (2.210)	47,62 (1.875)
SLEB	19	130411-0001*	SLEB19T3PM	63,50 (2.500)	74,94 (3.100)	56,13 (2.210)	47,62 (1.875)
SLEB	19	130411-0002*	SLEB19T3PN	63,50 (2.500)	74,94 (3.100)	56,13 (2.210)	47,62 (1.875)
SLEB	19	130411-0004*	SLEB19T3E	63,50 (2.500)	74,94 (3.100)	56,13 (2.210)	47,62 (1.875)
SLEB	19	130411-0005*	SLEB19T3	63,50 (2.500)	74,94 (3.100)	56,13 (2.210)	47,62 (1.875)
SLEC	28	130415-0000	SLEC28T3P	78,94 (3.108)	54,61 (2.150)	71,37 (2.810)	62,86 (2.475)
SLEC	28	130415-0001	SLEC28T3PM	78,94 (3.108)	54,61 (2.150)	71,37 (2.810)	62,86 (2.475)
SLEC	28	130415-0002	SLEC28T3PN	78,94 (3.108)	54,61 (2.150)	71,37 (2.810)	62,86 (2.475)
SLEC	28	130415-0004	SLEC28T3PE	78,94 (3.108)	54,61 (2.150)	71,37 (2.810)	62,86 (2.475)
SLEC	28	130415-0005	SLEC28T3	78,94 (3.108)	54,61 (2.150)	71,37 (2.810)	62,86 (2.475)

*Select polarization, see page 23.

Recommended PCB Layout, Straight

SLE B19 (19 contacts)

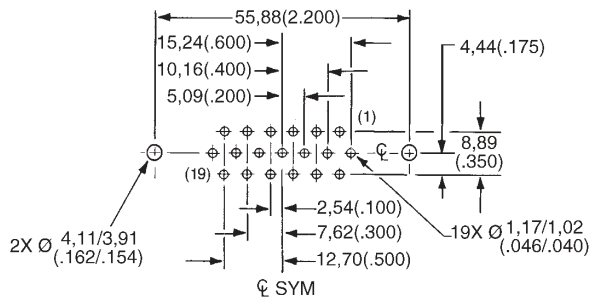

SLE C28 (28 contacts)

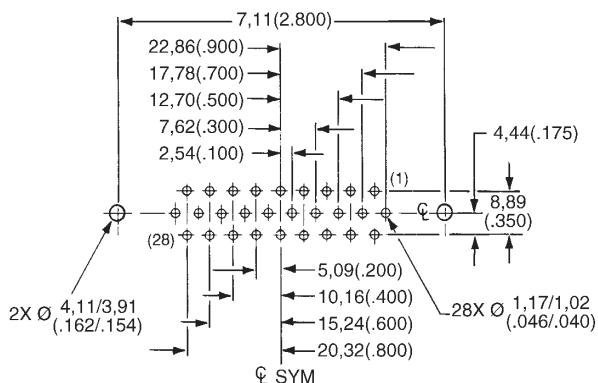

Dimensions shown in mm
Specifications and dimensions subject to change

www.ittcannon.com

Plug, PCB, 90°

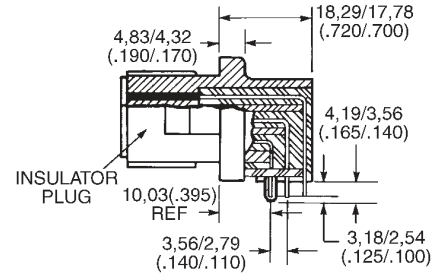
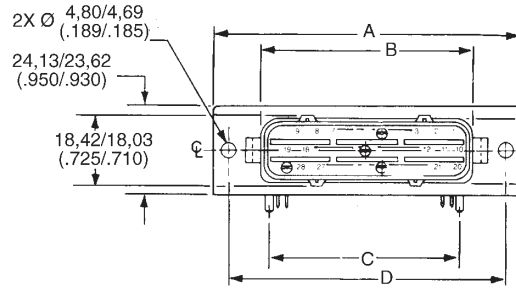

Panel Cutout

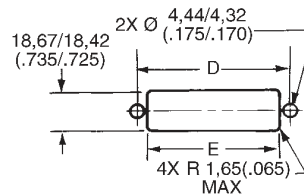

PANEL THICKNESS .200 MAX

Shell Size	Number of Contacts	Part Number*	Nomenclature	A Max.	B Max.	C Max.	D Max.	E Max.
SLEB	19	130410-0000*	SLEB19N3P	63,50 (2.500)	74,94 (3.100)	35,81 (1.410)	56,13 (2.210)	47,62 (1.875)
SLEB	19	130410-0001*	SLEB19N3PM	63,50 (2.500)	74,94 (3.100)	35,81 (1.410)	56,13 (2.210)	47,62 (1.875)
SLEB	19	130410-0002*	SLEB19N3PN	63,50 (2.500)	74,94 (3.100)	35,81 (1.410)	56,13 (2.210)	47,62 (1.875)
SLEB	19	130410-0004*	SLEB19N3	63,50 (2.500)	74,94 (3.100)	35,81 (1.410)	56,13 (2.210)	47,62 (1.875)
SLEC	28	130414-0000	SLEC28N3P	78,94 (3.108)	54,61 (2.150)	51,05 (2.010)	71,37 (2.810)	62,86 (2.475)
SLEC	28	130414-0001	SLEC28N3PM	78,94 (3.108)	54,61 (2.150)	51,05 (2.010)	71,37 (2.810)	62,86 (2.475)
SLEC	28	130414-0002	SLEC28N3PN	78,94 (3.108)	54,61 (2.150)	51,05 (2.010)	71,37 (2.810)	62,86 (2.475)
SLEC	28	130414-0004	SLEC28N3	78,94 (3.108)	54,61 (2.150)	51,05 (2.010)	71,37 (2.810)	62,86 (2.475)

*Select polarization, see page 23.

Recommended PCB Layout, 90°

SLE B19 (19 contacts)

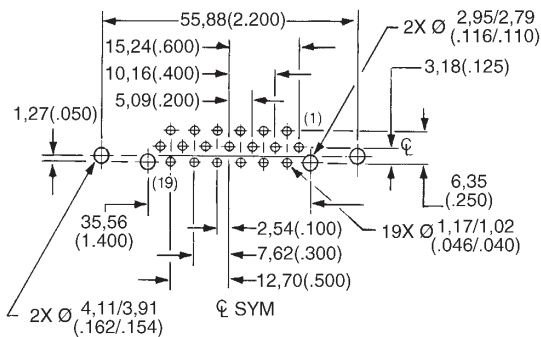

SLE C28 (28 contacts)

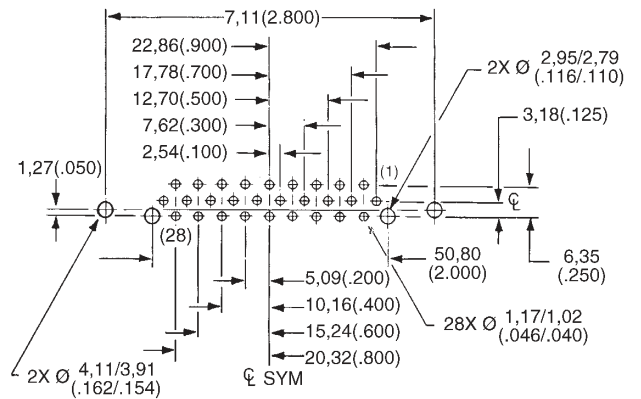

Dimensions shown in mm
 Specifications and dimensions subject to change

Contacts, Stamped, 5 and 13 Amp

Socket (use in plugs)

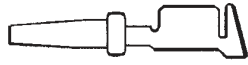

Hooded Socket

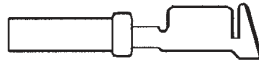

Pin (use in receptacles)

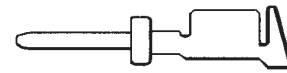

Hooded Socket

Reeled

Description	Socket Part Number	Pin Part Number	Socket Part Number	Number of Contacts
5 A	110238-1016 (030-2480-007)	110238-0446 (030-2464-007)	110238-04888 (030-2480-000)	4,500
13 A		110238-2004 (030-2464-003)	110238-2003 (030-2480-003)	4,000

Accessories

Sealing Plug



Material: Thermoplastic, Color: Natural
Part Number: 225-0093-000

Female Screw Lock



Order 2 per connector
Material: Steel
Finish: Zinc
Part Number: 265-0061-000

Latch Clip Retainer



Bail Latch For Redundant Latch Applications

SLEB	029-0281-000
SLEC	029-0281-001

Test Methods

Insulation Resistance	MIL-STD-1344	Method 3003.1
Dielectric Withstanding Voltage	MIL-STD-1344	Method 3001.1
Contact Resistance	MIL-STD-1344	Method 3004.1
Low Level Contact Resistance	MIL-STD-1344	Method 3002.1
Crimp Tensile Strength	MIL-STD-1344	Method 2003.1
Contact Retention	MIL-STD-1344	Method 2007.1
Mating Separating Force	MIL-STD-1344	Method 2013.1
Durability	MIL-STD-1344	Method 2016
Temperature Life	MIL-STD-202	Method 108 Condition D
Mechanical Shock	MIL-STD-202	Method 213 Condition I
Maintenance Aging	MIL-STD-1344	Method 2002.1
Vibration	MIL-STD-1344	Method 2005.1 Condition VI 20 Hours/Axis
Sand and Dust	MIL-STD-202	Method 110
Salt and Spray	MIL-STD-202	Method 101 Condition A
Humidity	MIL-STD-202	Method 106
Steam Cleaning/Pressure Wash	SAE	Proposed

Extraction Tool

Contact Extraction Tool
Part Number: 274-7068-001
Tip Part Number: 323-9519-000



A Standard CET - SLE/SLC is available for extraction of the individual crimp contacts. Insertion tool is not required.

Insertion/Extraction Instructions for Crimp Contacts

Insertion Tool

No insertion tool is required. The contact is easily snapped in from the rear of the connector manually.



1. Move to the rear of the connector so that the contact cavities can be identified.



2. Insert a crimp terminated assembly into a selected cavity.



3. Continue the forward movement until and audible snap can be felt and heard. Slight pull in the opposite direction will confirm complete insertion.

Extraction



1. Open the CET - SLE Extraction tool and place it over the insulation of the wire.



2. Using a straight motion forward, insert the tool along the wire until it bottoms against the connector. (Do not use a screwing motion - damage will result.)



3. While the extraction tool is in place, simply pull the wire/contact assembly out.



4. Remove the extraction tool. Extraction is complete.

Hand Crimp Tool Operation



Hand Crimp Tool - CCT - SLC / SLE
Part Number: 995-0002-232

The CCT-SLC/SLE hand crimp tool is designed to crimp individual SLC/SLE contacts on wire sizes 16, 18, and 20 AWG. Each cycle is ratchet-controlled (The tool must be completely closed before it can be reopened) to assure a satisfactory crimp each time. Over and under crimps are eliminated.

This tool is for use when the requirement is for low to moderate volume quantities, and for on-site applications where semi-automatic tools cannot be practically used.



1. Cycle the CCT - SLE / SLC hand tool to the open position.



2. While pressing upward on the locator spring, insert the contact with tails upward completely into the locator.



3. When correctly positioned the contact should be located beyond flush with the edge of the CCT - SLE / SLC and positioned in the concave polished split level crimp.



4. Partially (usually the first click) Cycle the hand tool assuring that the upward thrusting tails of the contact has started engaging with the top jaw of the tool. (There is a slight tendency for the contact to roll out of vertical alignment.)



5. Insert the pre-stripped wire into the crimp area of the contact and completely cycle the tool.



6. While pressing upward on the locator spring withdraw the crimp termination.



7. The result will be a perfect termination.



8. Note that there are no unterminated wire strands, and that some strand ends can be seen at the forward edge of the crimp. Also note the insulation is gripped by the smaller secondary crimp. Distortion is at a minimum, both axially and laterally - no sharp edges.

Wire Stripping

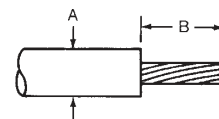

5 and 13 A Contact		
Tolerance	A	B
Low	2,41 (.095)	5,33 (.210)
High	3,30 (.130)	5,59 (.220)

Lease Automatic Tooling - North America*

ABT-607 Pneumatic Crimper



The ABT-607 is a pneumatic powered and controlled machine. It is designed for customers with moderate volume. This machine is designed to semi-automatically crimp stamped and formed contacts onto pre-stripped stranded or single conductor electrical wire. This machine will accommodate size 34 thru 12 AWG wire and is actuated by the use of a foot pedal.

Machine Crimp Rate:
800 per hour

Power Requirements:
Pneumatic = 100 psi, 2 cu. ft. per min.

ABT-500 UCCD



The ABT-500 Universal Cannon Crimp Die, is a flywheel driven, electronically controlled machine that is designed to semi-automatically crimp stamped and formed contacts on stranded or single conductor, pre-stripped wire. This machine will accommodate size 34 thru 12 WG wire. The machine is actuated by the use of a foot pedal.

Machine Crimp Rate:
1300 per hour

Power Requirements:
Electrical = 115VAC, 60Hz, 20A

ABT-620 UCCS



The ABT-620 Universal Cannon Crimper/Stripper is a pneumatic powered, microprocessor controlled machine. It is designed to semi-automatically strip insulation from stranded or single conductor electrical wire and attach a stamped and formed contact by crimping. The machine will accommodate 34 thru 12 AWG wire. Primary application of the machine is the termination of jacketed cable where the individual leads cannot be stripped by fully automated equipment. The ABT-620 UCCS operates automatically upon insertion of a wire or it can be switched over to foot pedal operation if desired.

Machine Crimp Rate:
1200+ per hour

Power Requirements:
Electrical = 115VAC, 60Hz, 20A
Pneumatic = 80 psi, 3 cu. ft. per min.

* For other geographical regions, contact Cannon for details.

Crimp Pot Cross Section

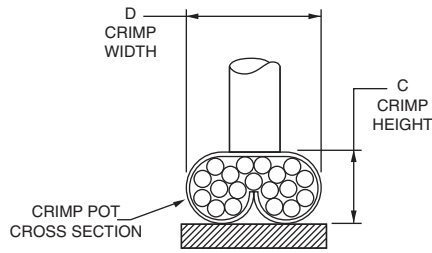

The wire crimp heights listed are only reference and valid for the correspondingly listed wire size, wire plating and wire stranding.

The wire crimp tensile values must be used to assure the performance of crimped contacts.

For wire crimp information not listed in this table, please contact Cannon.

Crimp Height and Width

	Wire Gauge (AWG)					
	16		18		20	
	C*	D Ref.	C*	D Ref.	C*	D Ref.
Signal (5A)	.064*	.082	.056*	.080	.054*	.080
Power (13A)	.066*	.082	.062*	.080	.058*	.080

* Hand Tools are ± .002 and machines are ± .001

Insulation Height and Width

	Wire Gauge (AWG)					
	16		18		20	
	Height Max	Width Max**	Height Max	Width Max**	Height Max	Width Max**
Signal (5A)	.110	.115**	.105	.110**	.105	.110**
Power (13A)	.110	.115**	.105	.110**	.105	.110**

** Measurements are taken without crimping wire insulation.

Crimp Tensile Strength

Wire Trim Dimension



Wire Size (AWG)	16	18	20
Tensile Min (lbs)	35 lbs.	25 lbs.	20lbs.



Test Parameters

SLC Products are designed to meet Cannon specifications CS-206, CS-210, and CS-216. Items of most general interest to users are designers are listed below.

Test Description	Reference Paragraph	Requirements																																							
Environmental Sealing	3.2.3.5 3.2.3.6 3.2.3.7 3.2.3.8 3.2.3.9 3.2.3.10	Sand and Dust MIL-STD-202 Method 110 Test Condition A 5% salt spray 96 hours 10 cycles of 24 hours, 90-98% humidity Steam Cleaning/Pressure Wash 95°C, 375 Cycles 750 PSIG Solvent Resistance/Immersion (see 3.2.3.9) Thermal Shock 100 Cycles -40°C to +125°C ± 3°C																																							
Contact Crimp Tensile Strength	3.2.2.1	The minimum tensile load required to separate the wire from the contact, either by pulling the wire out of the crimp joint or by breaking the wire within the crimp joint shall not be less than the applicable limits as specified. Wire breakage or contact damage not due to crimping at less than tensile loads shall not constitute a failure. <table border="1" style="margin-left: auto; margin-right: auto;"> <thead> <tr> <th>Wire Size AWG</th> <th>Crimp Tensile Strength, Pounds Minimum</th> </tr> </thead> <tbody> <tr> <td>16</td> <td>35</td> </tr> <tr> <td>18</td> <td>25</td> </tr> <tr> <td>20</td> <td>20</td> </tr> </tbody> </table>	Wire Size AWG	Crimp Tensile Strength, Pounds Minimum	16	35	18	25	20	20																															
Wire Size AWG	Crimp Tensile Strength, Pounds Minimum																																								
16	35																																								
18	25																																								
20	20																																								
Insulation Resistance	3.2.1.1	Mated and wired connectors shall exhibit an insulation resistance greater than 100 megohms between all contacts. This limit shall apply after exposure to each environment including salt solution immersion. Tests shall be performed at 100 VDC ± 10%.																																							
Dielectric Withstanding Voltage	3.2.1.2	Wired and mated connectors shall show no evidence of breakdown between adjacent contacts when tested at 1000 VDC ± 5%. Connectors shall meet this requirement after exposure to each environment. Current leakage shall be less than 1.0 milliamp.																																							
Low Level Contact Resistance	3.2.1.4	The low level contact resistance of mated contacts shall be less than 10 milliohms when measured across the contacts and crimp joints. The test current shall be a maximum of 100 milliamps with an open circuit test voltage of 20 millivolts maximum.																																							
Mechanical Shock	3.2.3.3	Connectors shall be subjected to three shocks in each direction applied along the three mutually perpendicular axes of the connector test specimen for a total of 12 shocks. Each shock shall consist of a terminal peak sawtooth pulse with a peak value of 100 g's and a duration of 6 milliseconds.																																							
Vibration	3.2.3.4	Connectors shall be subjected to random vibration in accordance with MIL-STD-1344, Method 2005.1, test condition VI for 20 hours along each of the following three axes: <table border="1" style="margin-left: auto; margin-right: auto;"> <thead> <tr> <th>Direction</th> <th>Grms</th> </tr> </thead> <tbody> <tr> <td>Transverse axis of connector (Y)</td> <td>22.8</td> </tr> <tr> <td>Longitudinal axis of connector (Z)</td> <td>12.2</td> </tr> <tr> <td>Mating axis</td> <td>10.2</td> </tr> </tbody> </table> Electrical continuity of the connectors shall be monitored during the last 20 minutes sweep in each axis with a test current of 100 milliamps or less and a test voltage less than 2VDC. Electrical discontinuities in excess of 10 microseconds shall be cause of failure.	Direction	Grms	Transverse axis of connector (Y)	22.8	Longitudinal axis of connector (Z)	12.2	Mating axis	10.2																															
Direction	Grms																																								
Transverse axis of connector (Y)	22.8																																								
Longitudinal axis of connector (Z)	12.2																																								
Mating axis	10.2																																								
Durability	3.2.2.5	Connectors shall be subjected to 25 cycles of mating and unmating at room temperature. Following this test there shall be no evidence of damage to the contacts, contact plating, connector housing or seals which may prove detrimental to reliable performance of the connector.																																							
Contact	3.2.2.2	Contacts shall not be displaced greater than 0.030 inches from the connector body when a force of 10 pounds is applied. When this test follows maintenance again the same contacts shall be tested.																																							
Maintenance Aging	3.2.2.3	Shall consist of subjecting each wired receptacle to 4 cycles of removal and reinsertion of 20% of the contacts or a minimum of 6 per connector with approved tooling.																																							
Mating and Separating Force	3.2.2.4	The maximum force required to mate the plug and receptacle shall be 25 pounds. The maximum force required to separate the plug and receptacle shall be 15 pounds. The rate of travel shall be one inch per minute.																																							
Solvent Resistance Immersion	3.2.2.9	Connectors shall be subjected to the following fluids at the temperature and length of time specified. Following the fluid dip or immersion, the connectors shall be immersed to a depth of 2 to 12 inches in a 5% salt-water solution for 24 hours at room temperature. At the completion of the salt-water immersion test, while still immersed, the connectors shall meet the insulation resistance requirement specified herein. <table border="1" style="margin-left: auto; margin-right: auto;"> <thead> <tr> <th>Fluid</th> <th>Method</th> <th>Temperature</th> </tr> </thead> <tbody> <tr> <td>No. 2 Diesel Fluid</td> <td>Immersion (2)</td> <td>140°F</td> </tr> <tr> <td>Methyl Alcohol</td> <td>Dip (1)</td> <td>Room Temperature</td> </tr> <tr> <td>Antifreeze</td> <td></td> <td></td> </tr> <tr> <td>- Prestone</td> <td>Immersion (2)</td> <td>180°F</td> </tr> <tr> <td>- 50% Water/50% Ethylene Glycol</td> <td>Immersion (2)</td> <td>180°F</td> </tr> <tr> <td>Degreaser</td> <td></td> <td></td> </tr> <tr> <td>- Gunk</td> <td>Dip (1)</td> <td>Room Temperature</td> </tr> <tr> <td>- Mineral Spirits</td> <td>Dip (1)</td> <td>Room Temperature</td> </tr> <tr> <td>Paint (Oil Base)</td> <td>Immersion (2)</td> <td>Room Temperature</td> </tr> <tr> <td>Lubricating Oil (SAE 10 W40)</td> <td>Immersion (2)</td> <td>200°F</td> </tr> <tr> <td>Brake Fluid (Delco Supreme)</td> <td>Dip (1)</td> <td>Room Temperature</td> </tr> <tr> <td>Transmission Fluid fully submerged and pressurized @ 7 psi. (Dextron)</td> <td>Dip (1)</td> <td>Room Temperature</td> </tr> </tbody> </table> (1) Dip: Connectors shall withstand a one second dip and a three minute air dry for a total of 80 cycles. (2) Immersion: Connectors shall withstand immersion for one hour.	Fluid	Method	Temperature	No. 2 Diesel Fluid	Immersion (2)	140°F	Methyl Alcohol	Dip (1)	Room Temperature	Antifreeze			- Prestone	Immersion (2)	180°F	- 50% Water/50% Ethylene Glycol	Immersion (2)	180°F	Degreaser			- Gunk	Dip (1)	Room Temperature	- Mineral Spirits	Dip (1)	Room Temperature	Paint (Oil Base)	Immersion (2)	Room Temperature	Lubricating Oil (SAE 10 W40)	Immersion (2)	200°F	Brake Fluid (Delco Supreme)	Dip (1)	Room Temperature	Transmission Fluid fully submerged and pressurized @ 7 psi. (Dextron)	Dip (1)	Room Temperature
Fluid	Method	Temperature																																							
No. 2 Diesel Fluid	Immersion (2)	140°F																																							
Methyl Alcohol	Dip (1)	Room Temperature																																							
Antifreeze																																									
- Prestone	Immersion (2)	180°F																																							
- 50% Water/50% Ethylene Glycol	Immersion (2)	180°F																																							
Degreaser																																									
- Gunk	Dip (1)	Room Temperature																																							
- Mineral Spirits	Dip (1)	Room Temperature																																							
Paint (Oil Base)	Immersion (2)	Room Temperature																																							
Lubricating Oil (SAE 10 W40)	Immersion (2)	200°F																																							
Brake Fluid (Delco Supreme)	Dip (1)	Room Temperature																																							
Transmission Fluid fully submerged and pressurized @ 7 psi. (Dextron)	Dip (1)	Room Temperature																																							
Temperature Life	3.2.3.1	Connectors shall be subjected to a temperature of 125°C ± 3°C for a period of 1000 hours. At the end of the temperature soak period and after removal from the chamber, the connectors shall meet the insulation resistance and dielectric withstanding voltage requirements specified herein. Connectors shall be operated at rated current throughout the duration of the temperature life test. Upon removal from the chamber at the conclusion of the test, the connectors shall show no visual signs of damage, which may be detrimental to the performance of the connector.																																							
Thermal Cycling	3.2.3.2	Connectors shall be subjected to 100 thermal cycles from -40°C to +125°C. One cycle shall consist of the transitions from room temperature to -40°C to +125°C, and from 125°C to room temperature. One cycle shall be accomplished in a three-hour period with a minimum stabilization period of 15 minutes at each temperature extreme. The chamber temperature transition rate shall be a minimum of 1.30°C per minute and a maximum of 6.00°C per minute.																																							

Crimp Pot Cross Section

The Vector connector offers low cost, light weight, environmental sealing with maximum space savings. High terminal density enable harnessing of both power (wire size 14-12 AWG) and signal (wire size 20-16 AWG) terminals within a single housing.

Secondary Terminal Locking

A single wedge provides secondary lock of all terminals reducing labor associated with wedge insertion. Assembly is fast and easy.

Positive Mating

The unique trapezoidal shape of the connector housing assures polarization and reliability by preventing incorrect mating or damage caused by mismatching. The dual latch assures reliable mating.

In-Line Design

An in-line design assures quick and simultaneous connection of terminals as well as versatility through partial loading of contacts when a full complement is not needed.



Features and Benefits

- Lightweight connector eliminates bulky components from your sensors, motors, and actuators
- Quick and simple assembly with hand-insertable contacts lowers your manufacturing costs
- Interfacial and individual wire seals provide superior sealing characteristics
- Available in signal (13 A) and power (25 A) versions for maximum rating flexibility

Product Specifications

Contact Resistance	20mΩ maximum
Insulation Resistance	100MΩ minimum (USCAR)
Current Rating	13 A signal continuous at 150°C all contacts, 2 position 25 A power continuous at 150°C all contacts, 5 position and 10 position only
Dielectric Withstanding Voltage	1000 Vrms AC at sea level
Applicable Cannon Specification	CS-211
Operating Temperature	Gold Contacts: -40°C to +150°C Tin Lead Contacts: -40°C to +105°C
Crimp Contacts	Semi-automatic or hand crimpable with individual wire seals
Wire Size	Signal: 20 - 16 AWG Power: 14 - 12 AWG
Wire Insulation Sealing Range	Signal: 1,29 (.051) to 2,80 (.110) Power: 2,03 (.0780) to 4,21 (.166)
Polarization	Trapezoidal interface
Contact Insertion	No tool required. Suitable for automation.
Contact Extraction	Rear Removable
Contact Retention	25 lbs. Minimum per contact
Wire Strip Length	Signal: 3,81 (.150) to 4,31 (.170) Power: 4,83 (.190) to 5,33 (.210)

Materials and Finishes

Connector Housing	High temperature thermoplastic
Environmental Seal	High temperature silicone elastomer
Contact Finish	Engaging area: Tin lead over nickel or selective gold optional Crimp area: Tin lead over nickel



Plug, Vector In-Line (Cable-to-Cable)

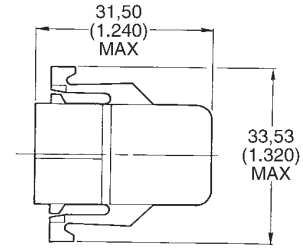
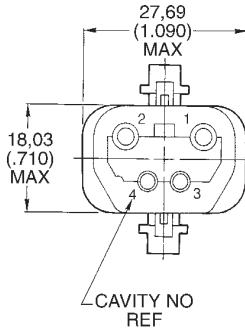

Description	Part Number	Reel Number	Insul. O.D.
Housing Recept., 4 pos.	083-1001-000	-	-
Secondary Lock, Socket Wedge	317-1803-000	-	-
Terminal, Signal	031-8719-121	121668-0202	-
Terminal, Power	031-8717-140	121688-0120	-
Wire Seal, Signal	980-0008-387	-	2,06 - 1,29 (.081 - .051)
Wire Seal, Power	980-0008-392	-	3,60 - 2,81 (.142 - .111)

For additional sizes, contact Cannon.

Receptacle, Vector In-Line (Cable-to-Cable)

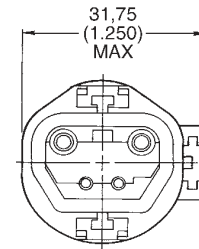
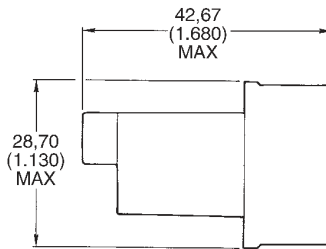

Description	Part Number	Reel Number	Insul. O.D.
Housing Recept., 4 pos.	083-1000-000	-	-
Secondary Lock, Pin Wedge	317-1802-000	-	-
Terminal, Signal	330-8673-104	121668-0122	-
Terminal, Power	330-8672-233	121688-0020	-
Interfacial Seal	273-3038-000	-	-
Wire Seal, Signal	980-0008-388	-	2,080 - 2,03 (.110 - .080)
Wire Seal, Power	980-0008-393	-	4,21 - 3,50 (.166 - .138)

Additional Part Numbers

Description	Insul. O.D. 2,06 - 1,29 (.081 - .051)	Insul. O.D. 2,42 - 2,26 (.095 - .089)	Insul. O.D. 2,80 - 2,03 (.110 - .080)
Wire Seal, Power	980-0008-389	980-0008-391	980-0008-390

Crimp Tool

Part Number: 140110-0000

Reliable, Cost effective crimp tooling is available for termination of power and signal contacts.



Dimensions shown in mm
Specifications and dimensions subject to change

www.ittcannon.com



Product Safety Information

THIS NOTE MUST BE READ IN CONJUNCTION WITH THE PRODUCT DATA SHEET/CATALOG. FAILURE TO OBSERVE THE ADVICE IN THIS INFORMATION SHEET AND THE OPERATING CONDITIONS SPECIFIED IN THE PRODUCT DATA SHEET/CATALOG COULD RESULT IN HAZARDOUS SITUATIONS.

1. MATERIAL CONTENT AND PHYSICAL FORM

Electrical connectors do not usually contain hazardous materials. They contain conducting and non-conducting materials and can be divided into two groups.

- a) Printed circuit types and low cost audio types which employ all plastic insulators and casings.
- b) Rugged, Fire Barrier and High Reliability types with metal casings and either natural rubber, synthetic rubber, plastic or glass insulating materials. Contact materials vary with type of connector and also application and are usually manufactured from either: Copper, copper alloys, nickel, alumel, chromel or steel. In special applications, other alloys may be specified.

2. FIRE CHARACTERISTICS AND ELECTRIC SHOCK HAZARD

There is no fire hazard when the connector is correctly wired and used within the specified parameters. Incorrect wiring or assembly of the connector or careless use of metal tools or conductive fluids, or transit damage to any of the component parts may cause electric shock or burns. Live circuits must not be broken by separating mated connectors as this may cause arcing, ionization and burning. Heat dissipation is greater at maximum resistance in a circuit. Hot spots may occur when resistance is raised locally by damage, e.g. cracked or deformed contacts, broken strands of wire. Local overheating may also result from the use of the incorrect application tools or from poor quality soldering or slack screw terminals. Overheating may occur if the ratings in the product Data Sheet/Catalog are exceeded and can cause breakdown of insulation and hence electric shock. If heating is allowed to continue it intensifies by further increasing the local resistance through loss of temper of spring contacts, formation of oxide film on contacts and wires and leakage currents through carbonization of insulation and tracking paths. Fire can then result in the presence of combustible materials and

this may release noxious fumes. Overheating may not be visually apparent. Burns may result from touching overheated components.

3. HANDLING

Care must be taken to avoid damage to any component parts of electrical connectors during installation and use. Although there are normally no sharp edges, care must be taken when handling certain components to avoid injury to fingers. Electrical connectors may be damaged in transit to the customers, and damage may result in creation of hazards. Products should therefore be examined prior to installation/use and rejected if found to be damaged.

4. DISPOSAL

Incineration of certain materials may release noxious or even toxic fumes.

5. APPLICATION

Connectors with exposed contacts should not be selected for use on the current supply side of an electrical circuit, because an electric shock could result from touching exposed contacts on an unmated connector. Voltages in excess of 30 V ac or 42.5 V dc are potentially hazardous and care should be taken to ensure that such voltages cannot be transmitted in any way to exposed metal parts of the connector body. The connector and wiring should be checked, before making live, to have no damage to metal parts or insulators, no solder blobs, loose strands, conducting lubricants, swarf, or any other undesired conducting particles. Circuit resistance and continuity check should be made to make certain that there are no high resistance joints or spurious conducting paths. Always use the correct application tools as specified in the Data Sheet/Catalog. Do not permit untrained personnel to wire, assemble or tamper with connectors. For operation voltage please see appropriate national regulations.

IMPORTANT GENERAL INFORMATION

(i) Air and creepage paths/Operating voltage. The admissible operating voltages depend on the individual applications and the valid national and other applicable safety regulations. For this reason the air and creepage path data are only reference values. Observe reduction of air and creepage paths due to PC board and/or harnessing.

(ii) Temperature

All information given are temperature limits. The operation temperature depends on the individual application.

(iii) Other important information

Cannon continuously endeavors to improve their products. Therefore, Cannon products may deviate from the description, technical data and shape as shown in this catalog and data sheets.

“Engineered for life” is a registered trademark of ITT Industries, ©2005. All other trademarks or registered trademarks are property of their respective owners. All data subject to change without notice.

Product Warranty

ITT Cannon, a Division of ITT Industries, Inc. manufactures the highest quality products available in the marketplace; however these products are intended to be used in accordance with the specifications in this publication. Any use or application that deviates from the stated operating specifications is not recommended and may be unsafe. No information and data contained in this publication shall be construed to create any liability on the part of Cannon. Any new issue of this publication shall automatically invalidate and supersede any and all previous issues. A limited warranty applies to Cannon products. Except for obligations assumed by Cannon under this warranty, Cannon shall not be liable for any loss, damage, cost of repairs, incidental or consequential damages of any kind, whether or not based on express or implied warranty, contract, negligence or strict liability arising in connection with the design, manufacture, sale, use or repair of the products. Product availability, prices and delivery dates are exclusively subject to our respective order confirmation form; the same applies to orders based on development samples delivered. This publication is not to be construed as an offer. It is intended merely as an invitation to make an offer. By this publication, Cannon does not assume responsibility or any liability for any patent infringements or other rights of third parties which may result from its use. Reprinting this publication is generally permitted, indicating the source. However, Cannon's prior consent must be obtained in all cases.





ITT

Connector Product Locations

With manufacturing facilities, sales representatives and distributors located worldwide, please visit our website at www.ittcannon.com for a complete listing and to find the office nearest you.

GERMANY

Cannonstrasse 1
Weinstadt, 71384
phone: 49.7151.699.0
fax: 49.7151.699.217

HONG KONG

Unit 901 & 912, West Tower
Shun Tak Center
168-200 Connaught Road
Central
phone: 852.2732.2720
fax: 852.2732.2919

ITALY

Via Pietro Panzeri 10
Milano, 20123
phone: 39.2.58180.1
fax: 39.2.8372036

UK

Jays Close, Viabes Estate
Basingstoke, RG22 4BA
phone: 44.1256.311200
fax: 44.1256.323356

USA

666 East Dyer Road
Santa Ana, CA 92705
toll free: 1.800.854.3028
phone: 1.714.557.4700
fax: 1.714.628.2142

"Engineered for life" is a registered trademark of ITT Industries. ©2005. All other trademarks or registered trademarks are property of their respective owners. All data subject to change without notice.

www.ittcannon.com

SLC 05-Sept