

LOC	DIST	REVISIONS				
CM	00	REV	DESCRIPTION	DATE	DWN	APVD
		AS1	REVISED PER ECO-11-005027	11MAR11	RK	HMR

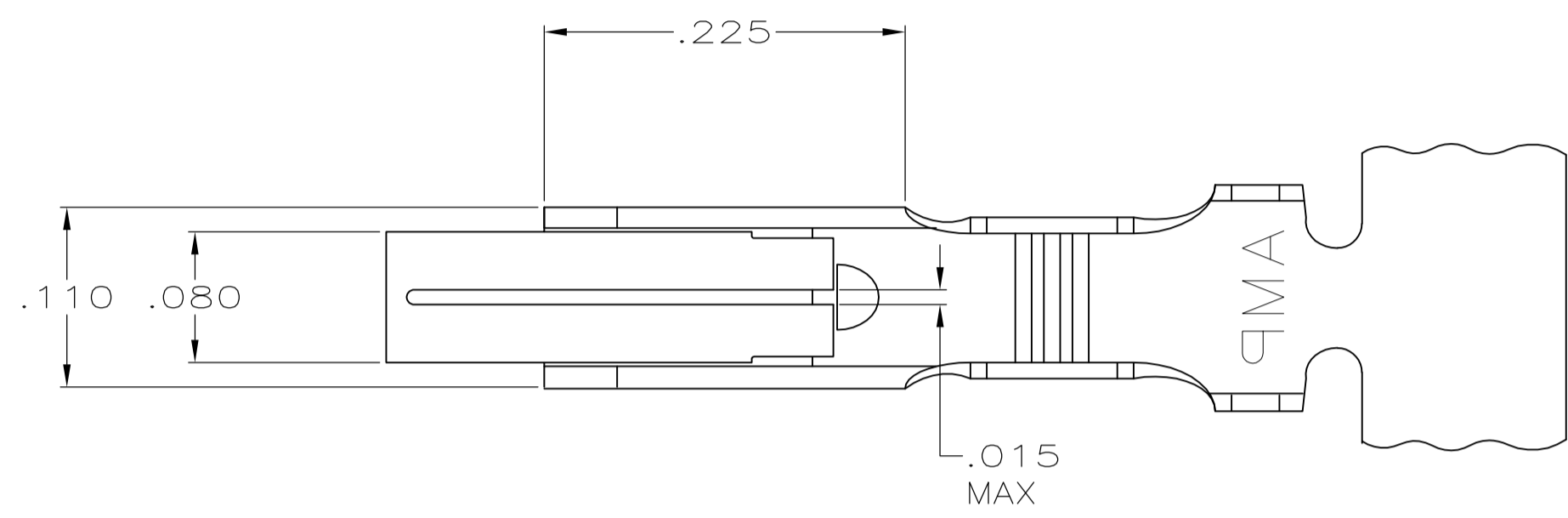

- 1 .000080 - .000200 TIN OVER .000050 MIN NICKEL
- 2 INSULATION RANGE: .100 DIA MAX. WIRE RANGE :24-18 AWG (0.02 - 0.9 MM<sup>2</sup>).
- 3 .000080 - .000200 TIN-LEAD OVER .000050 MIN NICKEL
- 4 .000050 NICKEL OVERALL WITH .000030 MIN GOLD IN THE LOCALIZED GOLD PLATE AREA (LGPA).

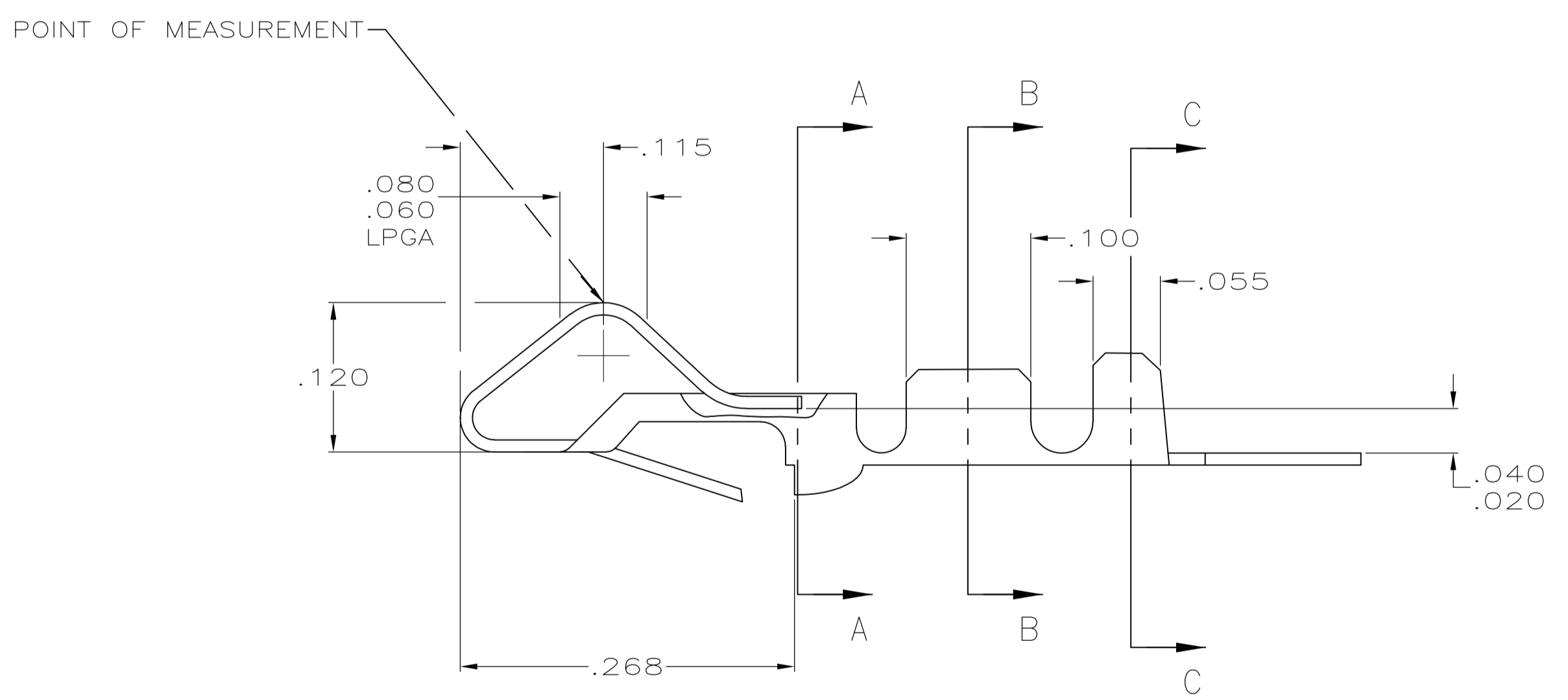
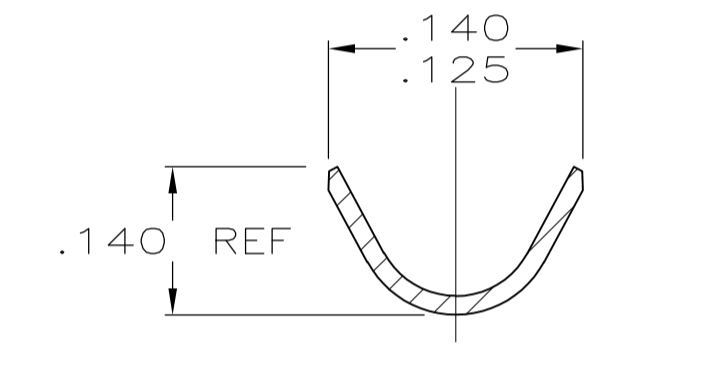
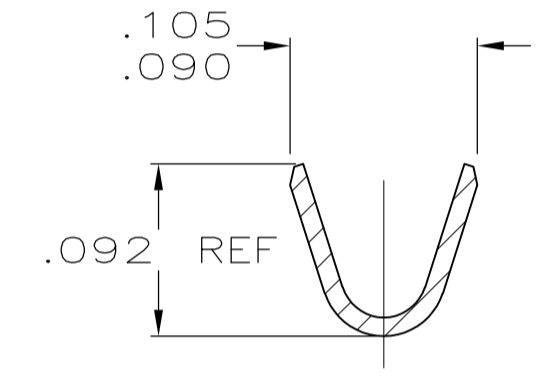
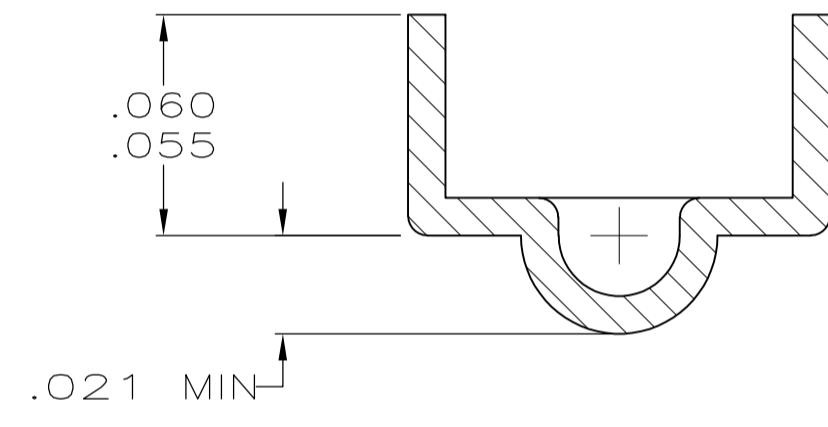

NOTES	FINISH	MATERIAL	PART NO.
-	1	.012 BRASS	3-61668-1
-	4	.012 PH BRZ	61668-4
-	PRE-TIN	.012 PH BRZ	61668-2
-	3	.012 BRASS	61668-1

THIS DRAWING IS A CONTROLLED DOCUMENT.

DWN: S. CARPENTER 21AUG2003  
CHK: J. ELLIS 21AUG2003

APVD: J. ELLIS 21AUG2003

NAME: CONTACT, BIFURCATED LEAF

PRODUCT SPEC: APPLICATION SPEC

SIZE: A1 CAGE CODE: 00779 DRAWING NO: 61668

WEIGHT: RESTRICTED TO: -

CUSTOMER DRAWING SCALE: 10:1 SHEET: 1 OF 1 REV: AS1