

Automotive IPD Series

2ch High Side Switch

BV2HM050EFV-C

General Description

BV2HM050EFV-C is a 2ch high side switch for automotive application. It has a built in hiccup mode overcurrent protection function, thermal shutdown protection function, open load detection function, under voltage lockout function. It is equipped with diagnostic output function for abnormality detection.

Features

- AEC-Q100 Qualified^(Note 1)
- Built in Hiccup Mode Overcurrent Protection Function (OCP)
- Built-in Thermal Shutdown Protection Function (TSD)
- Built-in Open Load Detection Function (OLD)
- Built-in Under Voltage Lockout Function (UVLO)
- Low On-Resistance $R_{ON} = 50\text{ m}\Omega$ (Typ)
- Monolithic Power Management IC with the Control Block (CMOS) and Power MOSFET Mounted on a Single Chip

(Note 1) Grade1

Key Specifications

- Power Supply Voltage Operating Range: 6 V to 28 V
- ON-Resistance ($T_j = 25\text{ }^\circ\text{C}$): 50 m Ω (Typ)
- Overcurrent Value: 5 A (Min)
- Standby Current ($T_j = 25\text{ }^\circ\text{C}$): 0.5 μA (Max)
- Active Clamp Energy ($T_j = 25\text{ }^\circ\text{C}$): 140 mJ

Package

HTSSOP-B20

W (Typ) x D (Typ) x H (Max)

6.5 mm x 6.4 mm x 1.0 mm

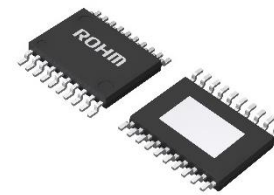

HTSSOP-B20

Application

- Resistance Load, Inductance Load and Capacitance Load for Automotive Application

Typical Application Circuit

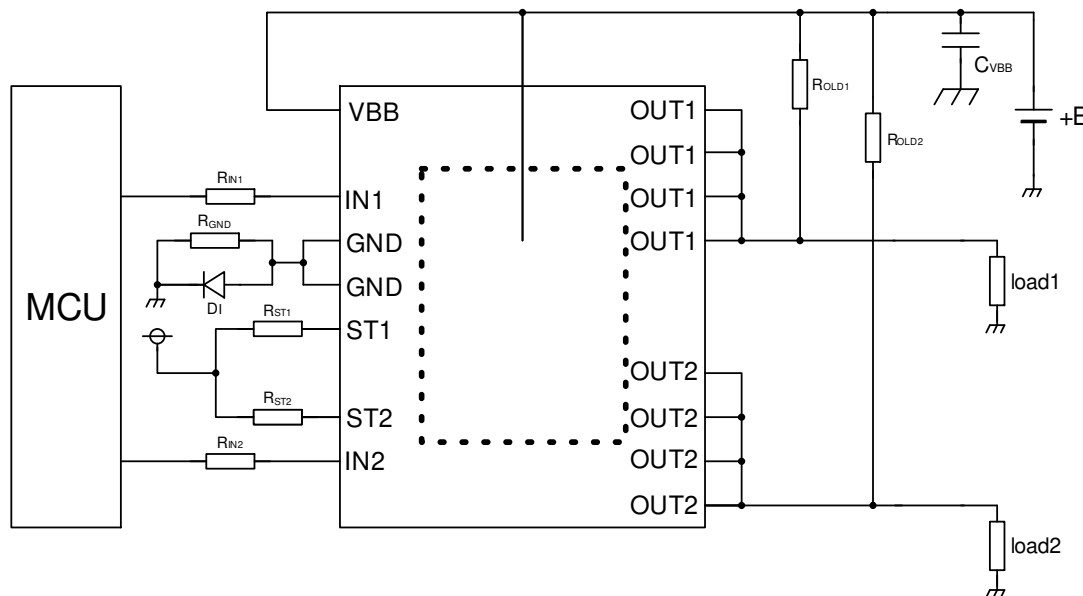

Figure 1. Application Circuit

Contents

General Description	1
Features.....	1
Application	1
Key Specifications	1
Package.....	1
Typical Application Circuit	1
Contents	2
Pin Configuration	3
Pin Description.....	3
Block Diagram	4
Definition.....	4
Absolute Maximum Ratings	5
Recommended Operating Conditions.....	6
Thermal Resistance.....	6
Electrical Characteristics.....	10
Typical Performance Curves.....	11
Measurement Circuits.....	16
Measurement Conditions for Time Items	19
Timing Chart	20
Description of Blocks	20
Applications Example	23
I/O Equivalence Circuits.....	24
Operational Notes.....	25
Ordering Information.....	27
Marking Diagram	27
Physical Dimension and Packing Information	28
Revision History.....	29

Pin Configuration

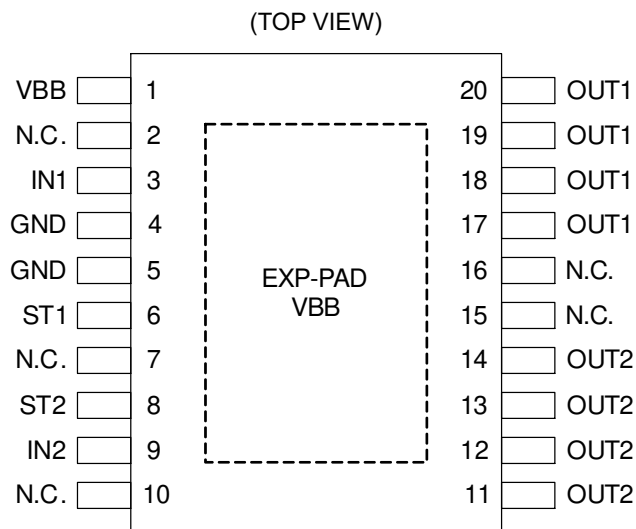

Figure 2. Pin Configuration

Pin Description

Pin No.	Pin Name	Function
1	VBB	Power input pin, switch input pin
2	N.C.	-
3	IN1	Channel 1 Input pin. Pull-down resistor is connected internally.
4	GND	Ground pin
5	GND	Ground pin
6	ST1	Channel 1 Self-diagnostic output pin
7	N.C.	-
8	ST2	Channel 2 Self-diagnostic output pin
9	IN2	Channel 2 Input pin. Pull-down resistor is connected internally.
10	N.C.	-
11 to 14	OUT2	Channel 2 Switch output pin
15	N.C.	-
16	N.C.	-
17 to 20	OUT1	Channel 1 Switch output pin
EXP-PAD	VBB	Power input pin, switch input pin

Block Diagram

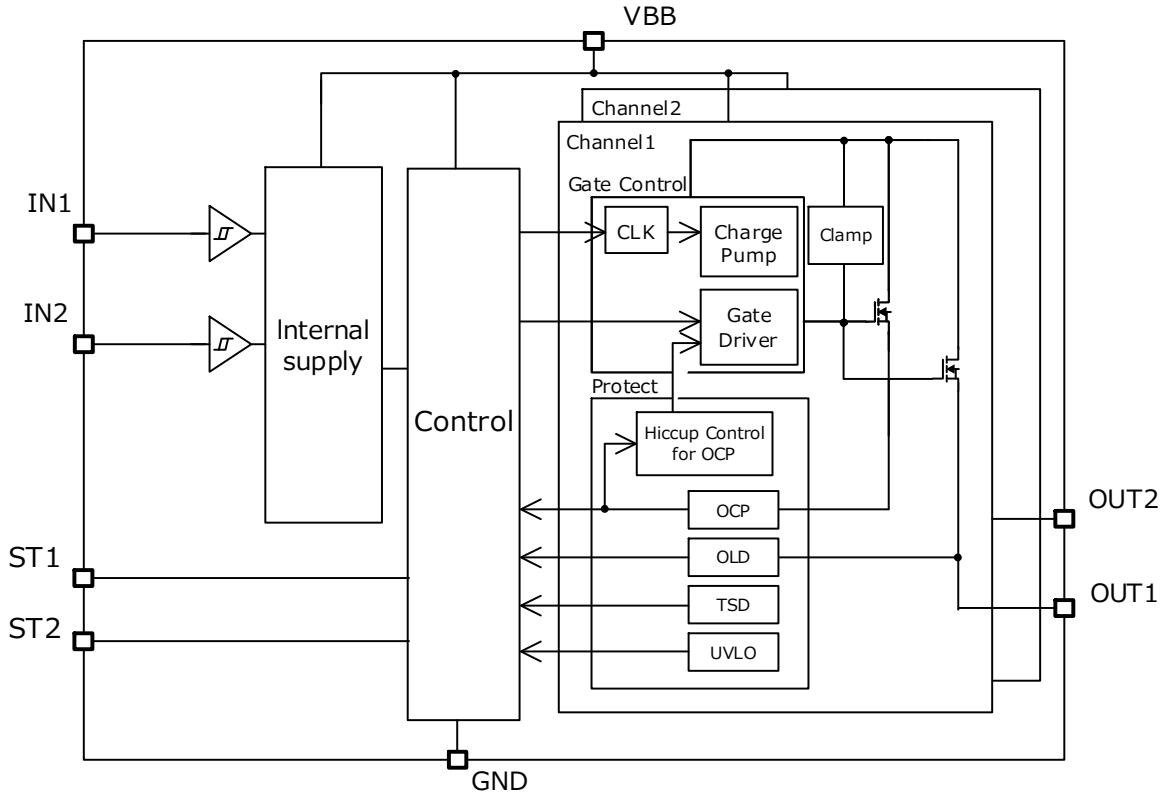

Figure 3. Block Diagram

Definition

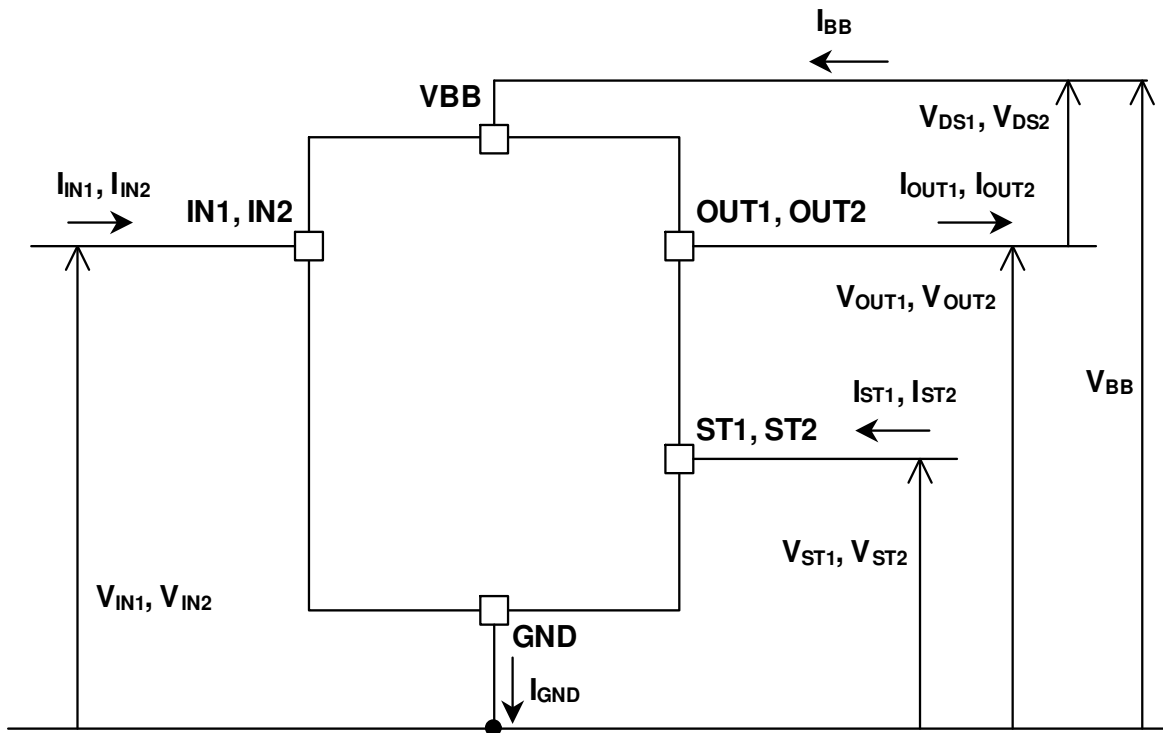

Figure 4. Voltage and Current Definition

Absolute Maximum Ratings (Ta = 25 °C)

Parameter	Symbol	Rating	Unit
VBB - OUT Voltage	V _{DS}	-0.3 to Internal clamp ^(Note 1)	V
Power Supply Voltage	V _{BB}	-0.3 to +40	V
Input Voltage	V _{IN1} , V _{IN2}	-0.3 to +7.0	V
Input Current	I _{IN1} , I _{IN2}	-2.0 to +2.0	mA
Diagnostic Output Voltage	V _{ST1} , V _{ST2}	-0.3 to +7.0	V
Output Current	I _{OUT1} , I _{OUT2}	11.0 (Overcurrent Value I _{OC}) ^(Note 2)	A
Junction Temperature Width	T _J	-40 to +150	°C
Storage Temperature Range	T _{stg}	-55 to +150	°C
Maximum Junction Temperature	T _{jmax}	150	°C
Active Clamp Energy ^{(Note 3) (Note 4)} (Single Pulse, T _J = 25 °C)	E _{AS}	140	mJ
Active Clamp Energy ^{(Note 3) (Note 4)} (Single Pulse, T _J = 150 °C)	E _{AS}	65	mJ
Supply Voltage for Short Circuit Protection ^{(Note 4) (Note 5)}	V _{BBLIM}	28	V

(Note 1) Internally limited by output clamp voltage.
 (Note 2) When overcurrent flows, output is turned off. (Output self-restarts after a certain time.)
 (Note 3) Maximum active clamp energy using Single Pulse of I_{OUT(START)} = 2 A and V_{BB} = 14 V.
 (Note 4) Not 100 % tested.
 (Note 5) Maximum power supply voltage that can detect short circuit protection.

- Caution 1:** Operating the IC over the absolute maximum ratings may damage the IC. The damage can either be a short circuit between pins or an open circuit between pins and the internal circuitry. Therefore, it is important to consider circuit protection measures, such as adding a fuse, in case the IC is operated over the absolute maximum ratings.
- Caution 2:** Should by any chance the maximum junction temperature rating be exceeded the rise in temperature of the chip may result in deterioration of the properties of the chip. In case of exceeding this absolute maximum rating, design a PCB with thermal resistance taken into consideration by increasing board size and copper area so as not to exceed the maximum junction temperature rating.
- Caution 3:** When IC turns off with an inductive load, reverse energy is generated. This energy can be calculated by the following equation:

$$E_L = \frac{1}{2} \times L \times I_{OUT(START)}^2 \times \left(1 - \frac{V_{BB}}{V_{BB} - V_{DS}}\right)$$

Where:
 L is the inductance of the inductive load.
 I_{OUT(START)} is the output current at the time of turning off.

The BV2HM050EFV-C integrates the active clamp function to internally absorb the reverse energy E_L which is generated when the inductive load is turned off. When the active clamp operates, the thermal shutdown function does not work. Decide a load so that the reverse energy E_L is active clamp energy E_{AS} (refer to Figure 5. Active Clamp Energy vs Output Current) or under when inductive load is used.

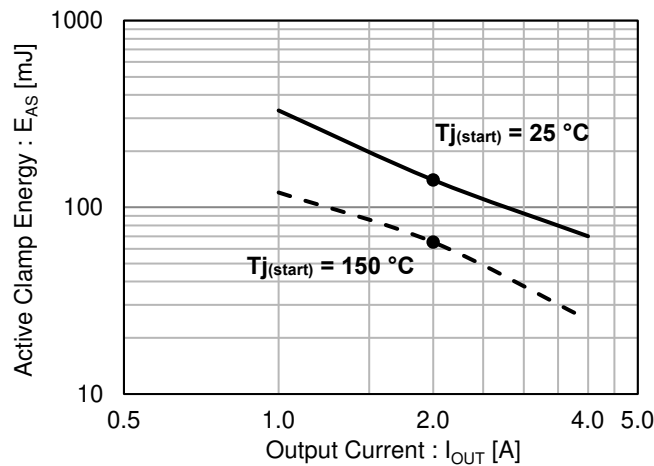

Figure 5. Active Clamp Energy vs Output Current

Recommended Operating Conditions

Parameter	Symbol	Min	Typ	Max	Unit
Operating Power Supply Voltage	V _{BB}	6	14	28	V
Operating Temperature	T _{opr}	-40	+25	+150	°C
Operating Frequency (Input Voltage 50 % Duty)	f _{IN}	-	-	1	kHz

Thermal Resistance *(Note 1)*

Parameter	Symbol	Typ	Unit	Condition
HTSSOP-B20				
Between Junction and Surroundings Temperature Thermal Resistance	θ _{JA}	108.1	°C/W	1s <i>(Note 2)</i>
		42.4	°C/W	2s <i>(Note 3)</i>
		33.1	°C/W	2s2p <i>(Note 4)</i>

(Note 1) The thermal impedance is based on JESD51-2A (Still-Air) standard. It is used the chip of BV2HM050EFV-C

(Note 2) JESD51-3 standard FR4 114.3 mm x 76.2 mm x 1.57 mm 1-layer (1s)

(Top copper foil: ROHM recommended footprint + wiring to measure, 2 oz. copper.)

(Note 3) JESD51-5 standard FR4 114.3 mm x 76.2 mm x 1.60 mm 2-layer (2s)

(Top copper foil: ROHM recommended Footprint + wiring to measure

Copper foil area on the reverse side of PCB: 74.2 mm x 74.2 mm, copper (top & reverse side) 2 oz.)

(Note 4) JESD51-5 / -7 standard FR4 114.3 mm x 76.2 mm x 1.60 mm 4-layers (2s2p)

(Top copper foil: ROHM recommended Footprint + wiring to measure

2 inner layers and copper foil area on the reverse side of PCB: 74.2 mm x 74.2 mm, copper (top & reverse side / inner layers) 2 oz / 1 oz.)

■ PCB Layout 1 layer (1s)

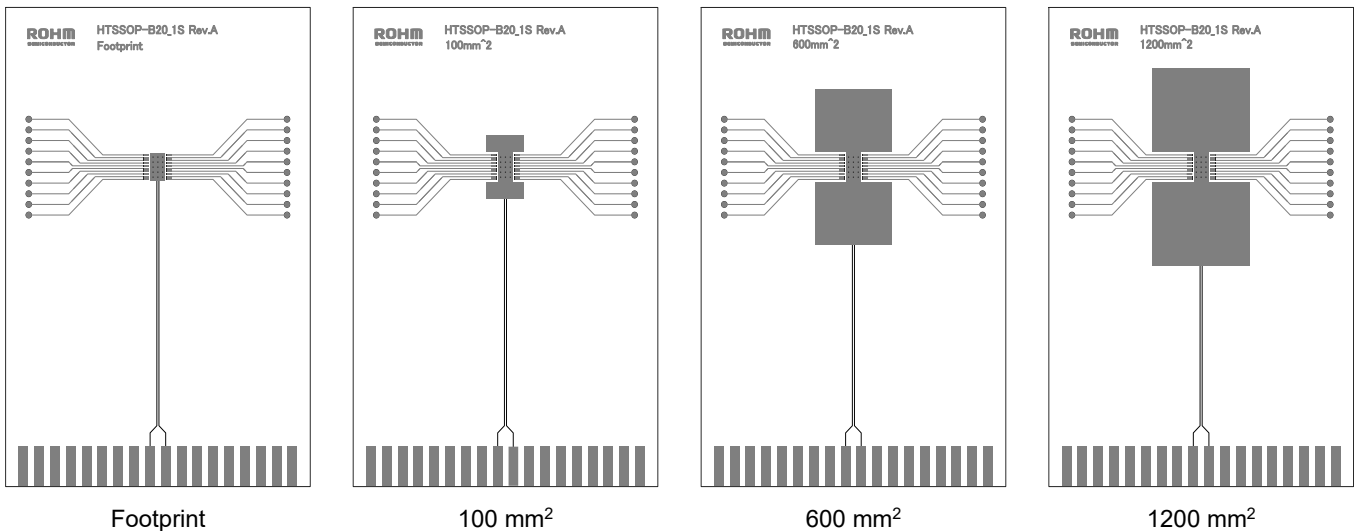

Figure 6. PCB Layout 1 layer (1s)

Dimension	Value
Board finish thickness	1.57 mm
Board dimension	76.2 mm x 114.3 mm
Board material	FR4
Copper thickness	0.070 mm (Cu: 2oz)
Copper foil area	Footprint / 100 mm ² / 600 mm ² / 1200 mm ²

Thermal Resistance – continued

■ PCB Layout 2 layers (2s)

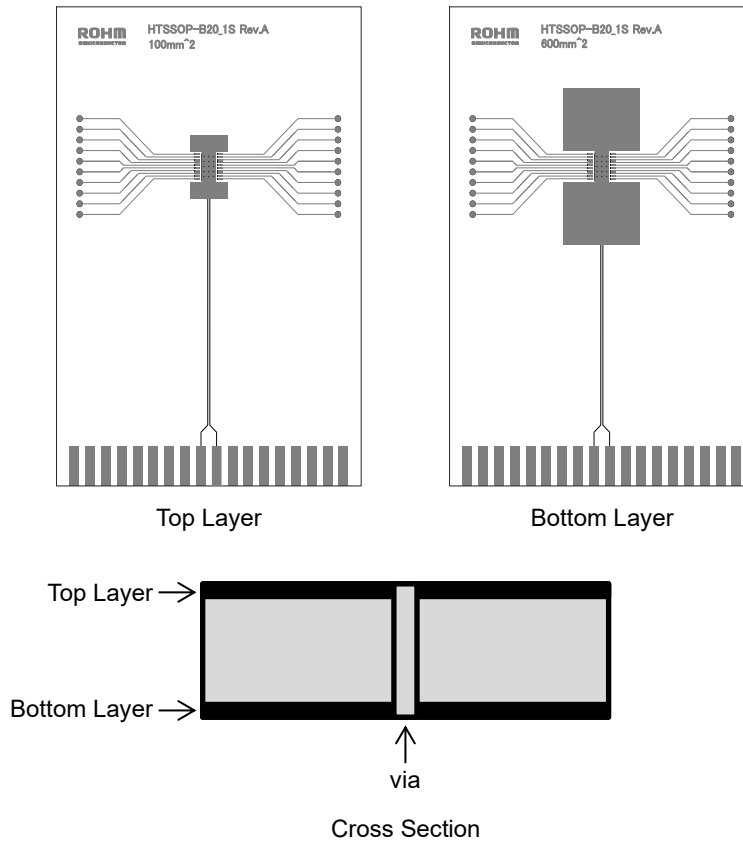

Figure 7. PCB Layout 2 layers (2s)

Dimension	Value
Board finish thickness	1.60 mm
Board dimension	76.2 mm x 114.3 mm
Board material	FR4
Copper thickness (Top / Bottom layers)	0.070 mm (Cu: 1oz + Plating)
Thermal vias separation / diameter	1.2 mm / 0.3 mm

Thermal Resistance – continued

■ PCB Layout 4 layers (2s2p)

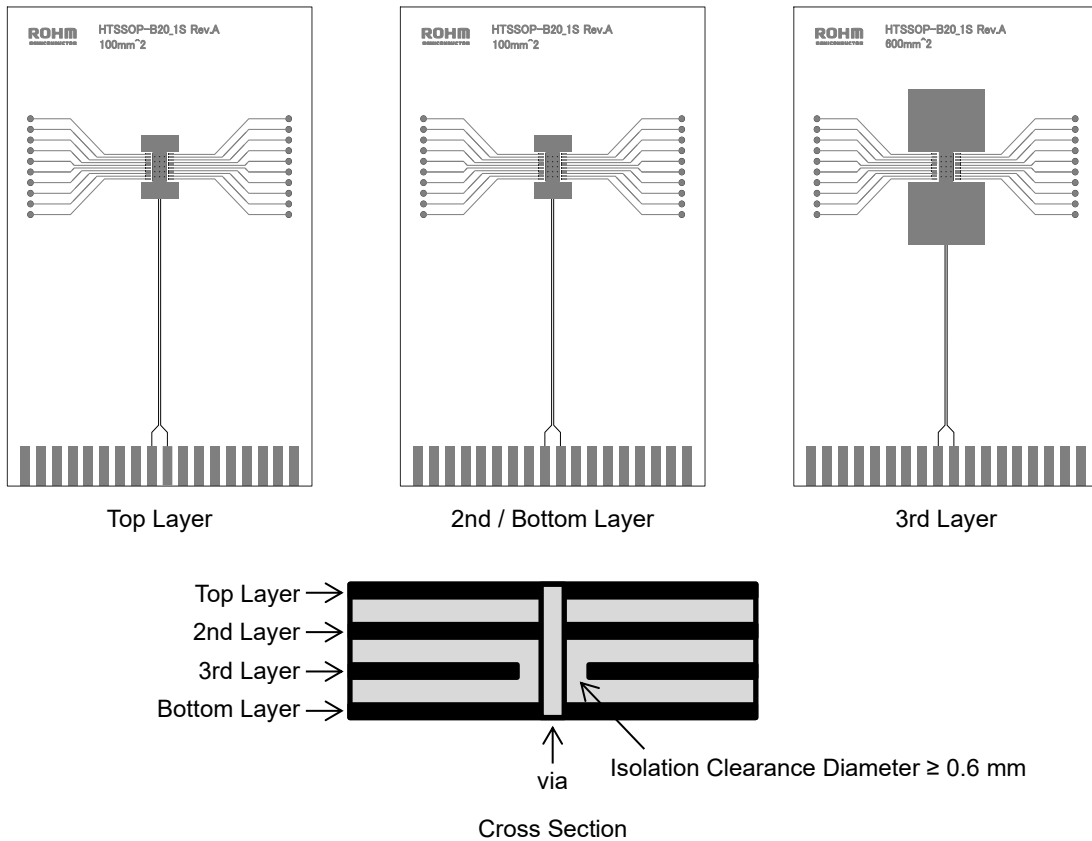

Figure 8. PCB Layout 4 layers (2s2p)

Dimension	Value
Board finish thickness	1.60 mm
Board dimension	76.2 mm x 114.3 mm
Board material	FR4
Copper thickness (Top / Bottom layers)	0.070 mm (Cu: 1oz + Plating)
Copper thickness (Inner layers)	0.035 mm
Thermal vias separation / diameter	1.2 mm / 0.3 mm

Thermal Resistance – continued

■ Transient Thermal Resistance (Single Pulse)

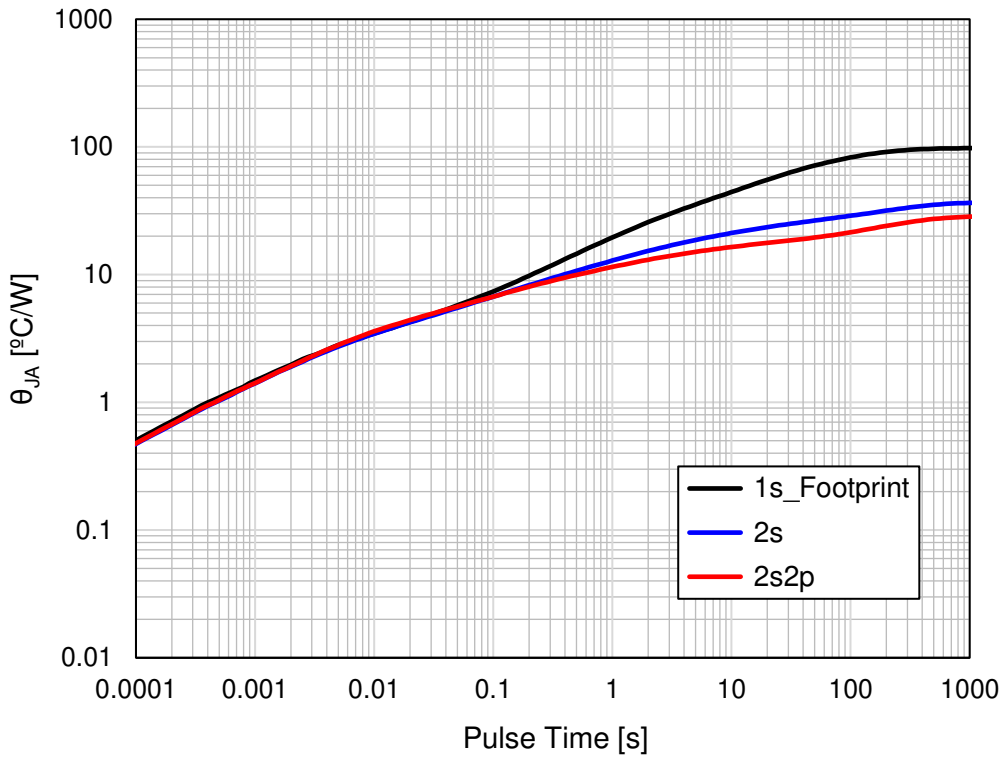

Figure 9. Transient Thermal Resistance

■ Thermal Resistance (θ_{JA} vs Copper foil area- 1s)

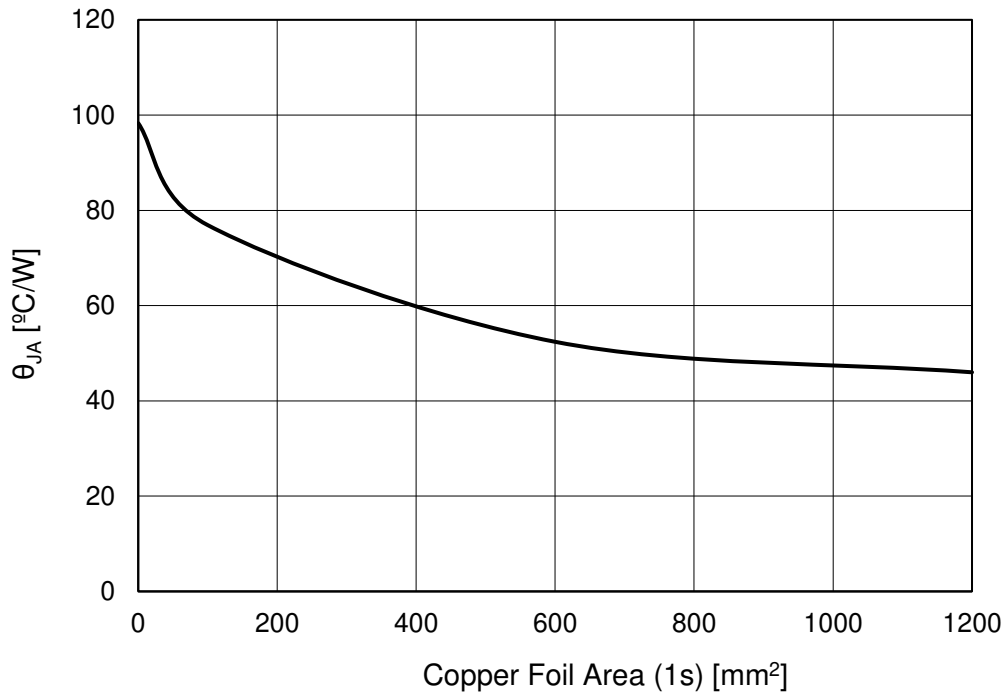

Figure 10. Thermal Resistance

Electrical Characteristics (unless otherwise specified $V_{BB} = 6\text{ V to }28\text{ V}$, $T_j = -40\text{ °C to }+150\text{ °C}$)

Parameter	Symbol	Limit			Unit	Conditions
		Min	Typ	Max		
[Power Supply]						
Standby Current	I _{BBL1}	-	-	0.5	μA	V _{BB} = 14 V, V _{IN} = 0 V, V _{OUT} = 0 V, T _j = 25 °C
	I _{BBL2}	-	-	20	μA	V _{BB} = 14 V, V _{IN} = 0 V, V _{OUT} = 0 V, T _j = 150 °C
Operating Current	I _{BBH}	-	5	10	mA	V _{BB} = 14 V, V _{IN} = 5 V, V _{OUT} = Open
UVLO Detection Voltage	V _{UVLO}	-	-	5.0	V	
UVLO Hysteresis Voltage	V _{UVHYS}	-	-	1.0	V	
[Input (V _{IN1} , V _{IN2})]						
High Level Input Voltage	V _{INH}	2.1	-	-	V	
Low Level Input Voltage	V _{INL}	-	-	0.9	V	
Input Hysteresis Voltage	V _{HYS}	-	0.3	-	V	
High Level Input Current	I _{INH}	-	50	150	μA	V _{IN} = 5 V
Low Level Input Current	I _{INL}	-10	-	+10	μA	V _{IN} = 0 V
[Power MOS Output]						
Output ON Resistance	R _{ON1}	-	50	65	mΩ	V _{BB} = 8 V to 18 V, T _j = 25 °C
	R _{ON2}	-	-	115	mΩ	V _{BB} = 8 V to 18 V, T _j = 150 °C
	R _{ON3}	-	-	90	mΩ	V _{BB} = 6 V, T _j = 25 °C
Output Leak Current	I _{OUTL1}	-	-	0.5	μA	V _{IN} = 0 V, V _{OUT} = 0 V, T _j = 25 °C
	I _{OUTL2}	-	-	20	μA	V _{IN} = 0 V, V _{OUT} = 0 V, T _j = 150 °C
Output Slew Rate when ON	SR _{ON}	0.05	0.20	0.50	V/μs	V _{BB} = 14 V, R _L = 6.5 Ω
Output Slew Rate when OFF	SR _{OFF}	0.05	0.20	0.50	V/μs	V _{BB} = 14 V, R _L = 6.5 Ω
Output Propagation Delay Time when ON	t _{OUTON}	-	70	160	μs	V _{BB} = 14 V, R _L = 6.5 Ω
Output Propagation Delay Time when OFF	t _{OUTOFF}	-	70	160	μs	V _{BB} = 14 V, R _L = 6.5 Ω
Output Clamp Voltage	V _{DSCLP}	45	50	55	V	V _{IN} = 0 V, I _{OUT} = 10 mA
[Diagnostics]						
Diagnostic Output Low Voltage	V _{STL}	-	-	0.5	V	I _{ST} = 1 mA
Diagnostic Output Leak Current	I _{STL}	-	-	10	μA	V _{ST} = 5 V
Diagnostic Output Propagation Delay Time when ON	t _{STON}	10	50	100	μs	
Diagnostic Output Propagation Delay Time when OFF	t _{STOFF}	125	300	500	μs	
[Protection Circuit]						
Overcurrent Value	I _{OC}	5	8	11	A	V _{OUT} = 0 V
Overcurrent Detection ON Time	t _{OCON}	-	10	40	μs	V _{OUT} = 0 V
Overcurrent Detection OFF Time	t _{OCOFF}	1.0	2.5	4.0	ms	
Open Load Detection Voltage	V _{OLD}	2.0	3.0	4.0	V	
Open Load Detection Sink Current	I _{OLD}	-	20	60	μA	V _{IN} = 0 V, V _{OUT} = 5 V
Thermal Shutdown Detection Temperature (Note 1)	T _{TSDDET}	160	185	210	°C	
Thermal Shutdown Release Temperature (Note 1)	T _{TSDREL}	150	-	-	°C	
Thermal Shutdown Hysteresis Temperature (Note 1)	T _{TSDHYS}	-	10	-	°C	

(Note 1) Not 100 % tested.

Typical Performance Curves

(Unless otherwise specified $V_{BB} = 14\text{ V}$, $V_{IN} = 5\text{ V}$, $T_j = 25\text{ }^\circ\text{C}$)

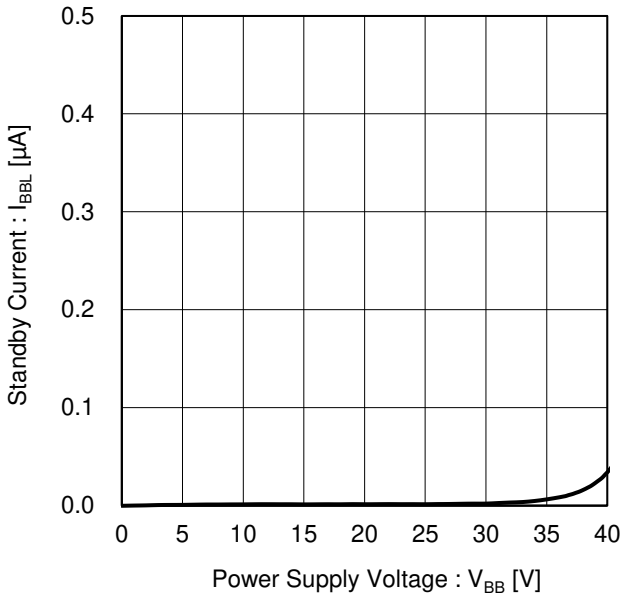

Figure 11. Standby Current vs Power Supply Voltage

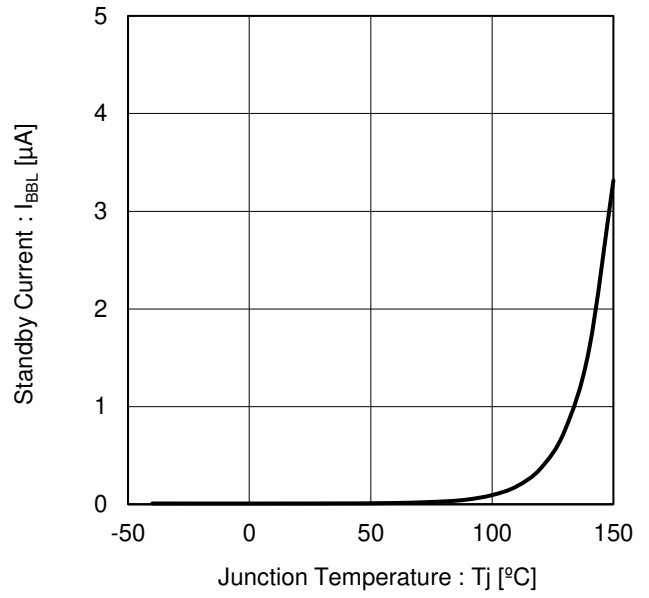

Figure 12. Standby Current vs Junction Temperature

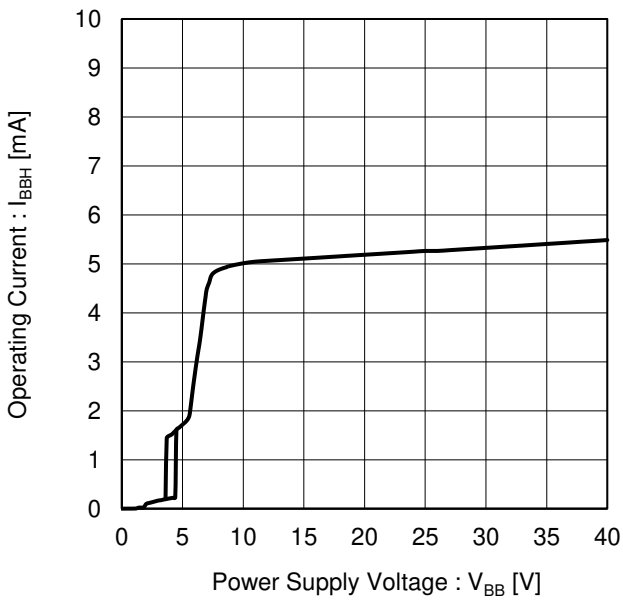

Figure 13. Operating Current vs Power Supply Voltage

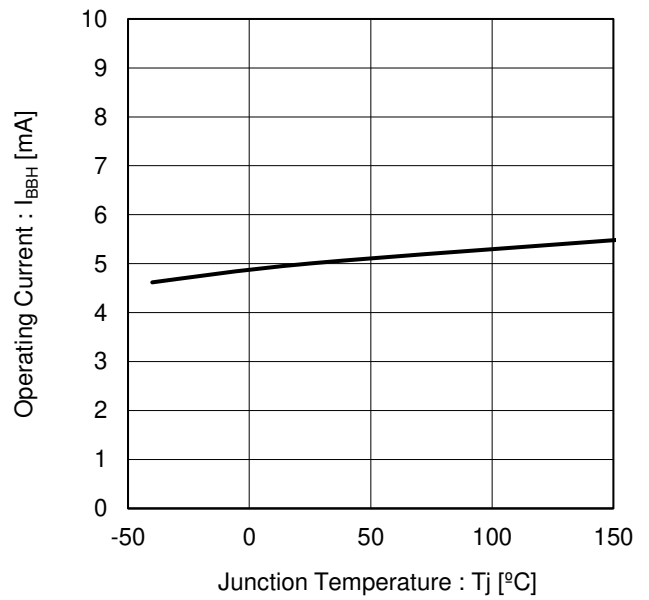

Figure 14. Operating Current vs Junction Temperature

Typical Performance Curves - continued

(Unless otherwise specified $V_{BB} = 14\text{ V}$, $V_{IN} = 5\text{ V}$, $T_j = 25\text{ }^\circ\text{C}$)

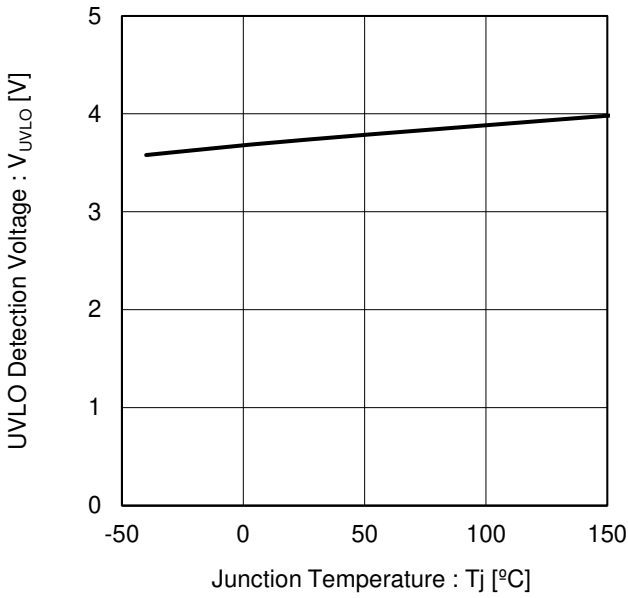

Figure 15. UVLO Detection Voltage vs Junction Temperature

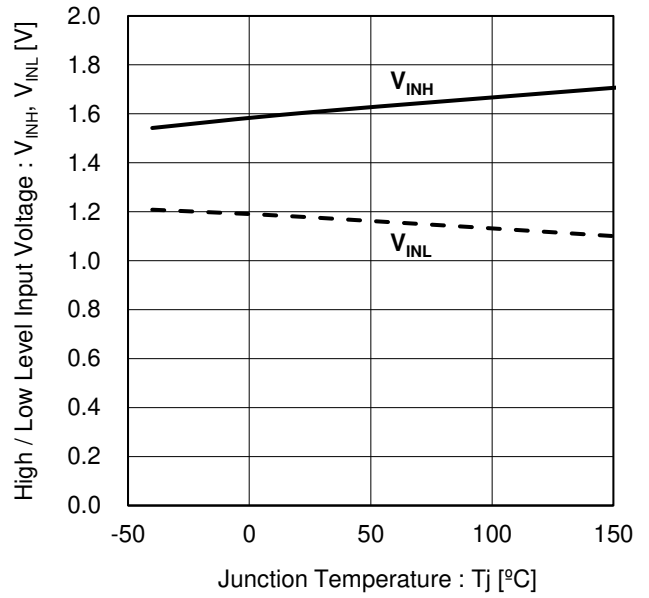

Figure 16. High / Low Level Input Voltage vs Junction Temperature

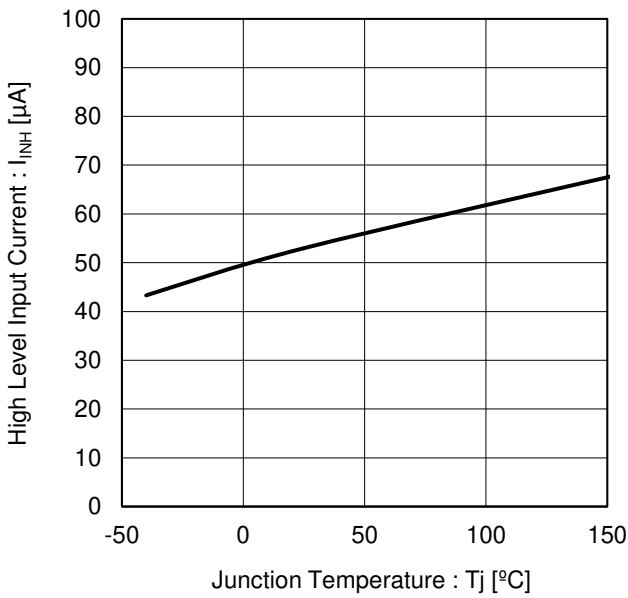

Figure 17. High Level Input Current vs Junction Temperature

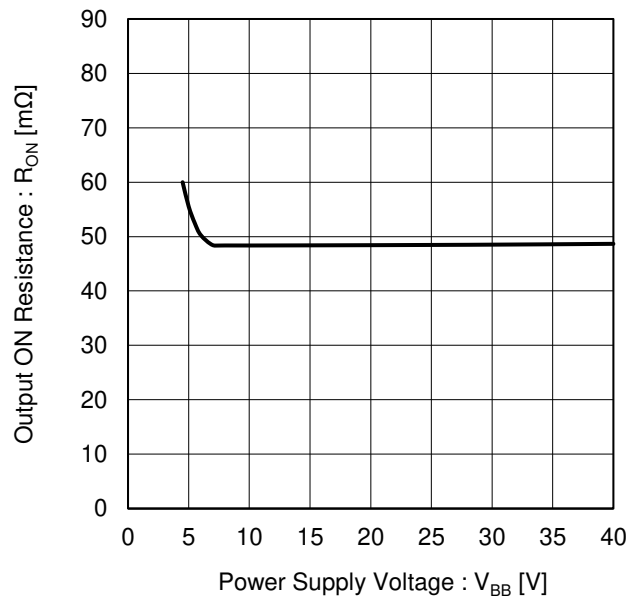

Figure 18. Output ON Resistance vs Power Supply Voltage

Typical Performance Curves - continued

(Unless otherwise specified $V_{BB} = 14\text{ V}$, $V_{IN} = 5\text{ V}$, $T_j = 25\text{ }^\circ\text{C}$)

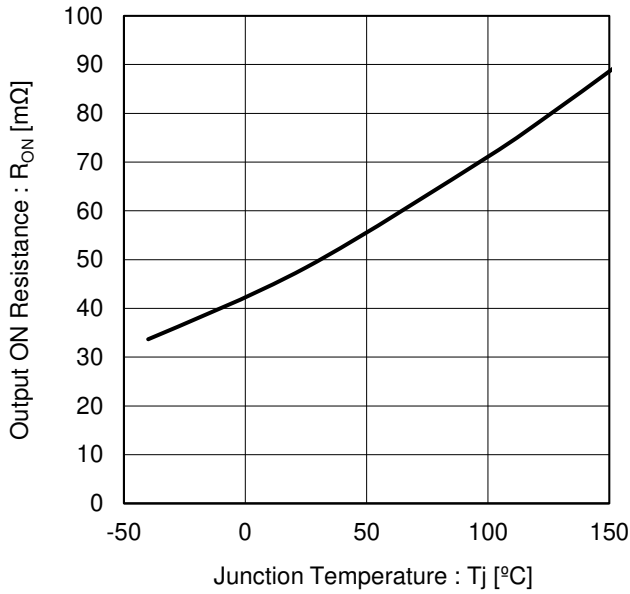

Figure 19. Output ON Resistance vs Junction Temperature

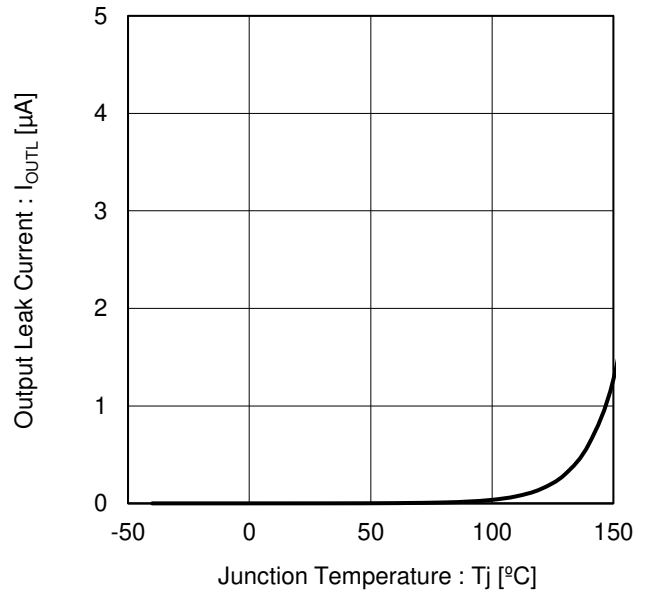

Figure 20. Output Leak Current vs Junction Temperature

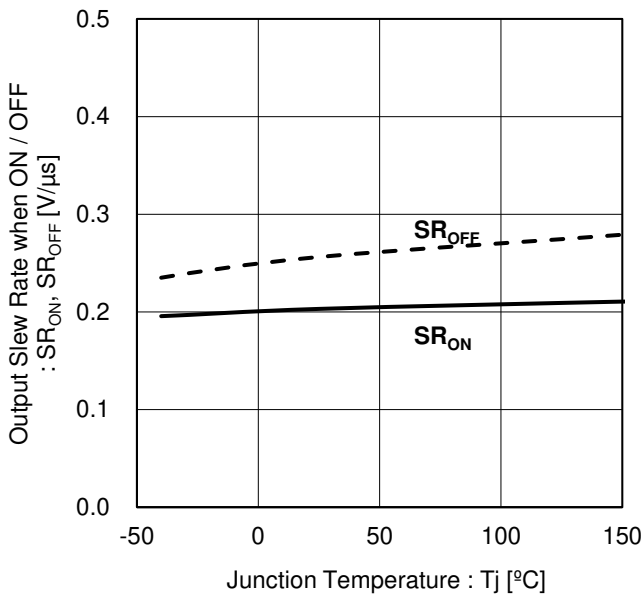

Figure 21. Output Slew Rate when ON / OFF vs Junction Temperature

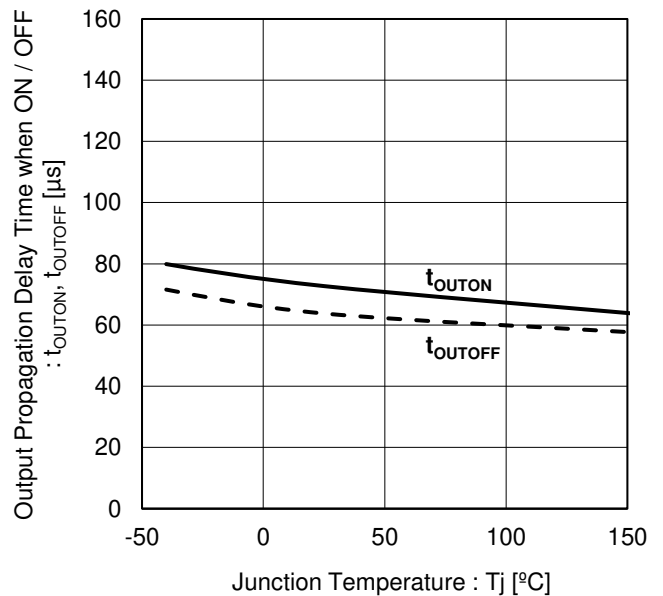

Figure 22. Output Propagation Delay Time when ON / OFF vs Junction Temperature

Typical Performance Curves - continued

(Unless otherwise specified $V_{BB} = 14\text{ V}$, $V_{IN} = 5\text{ V}$, $T_j = 25\text{ }^\circ\text{C}$)

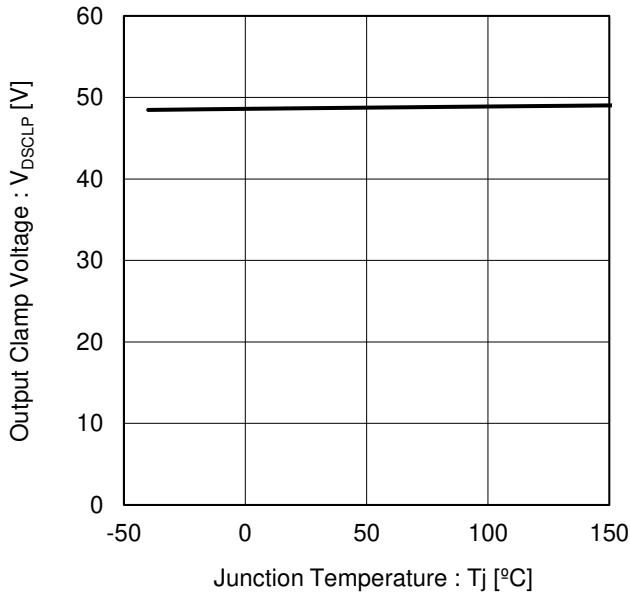

Figure 23. Output Clamp Voltage vs Junction Temperature

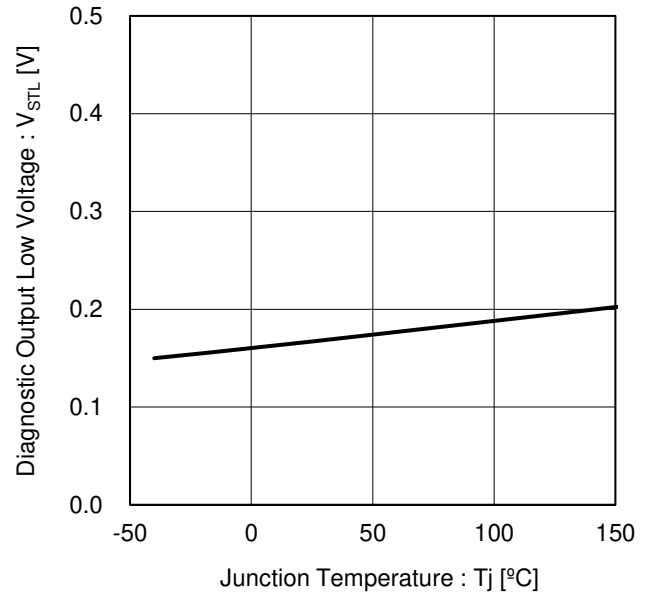

Figure 24. Diagnostic Output Low Voltage vs Junction Temperature

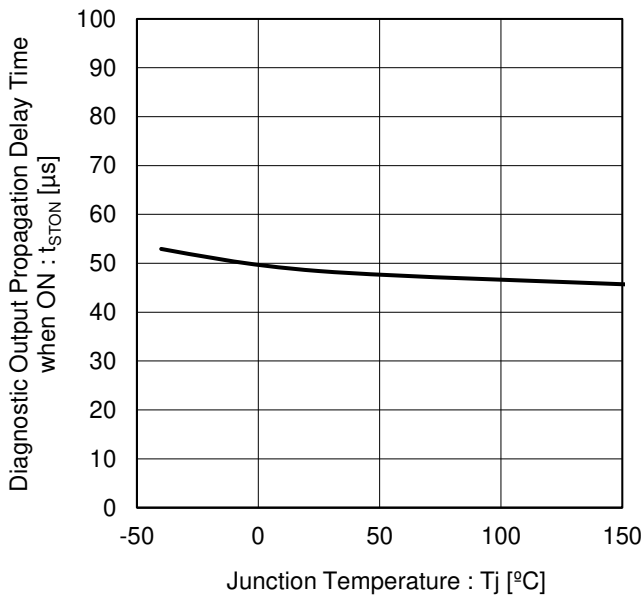

Figure 25. Diagnostic Output Propagation Delay Time when ON vs Junction Temperature

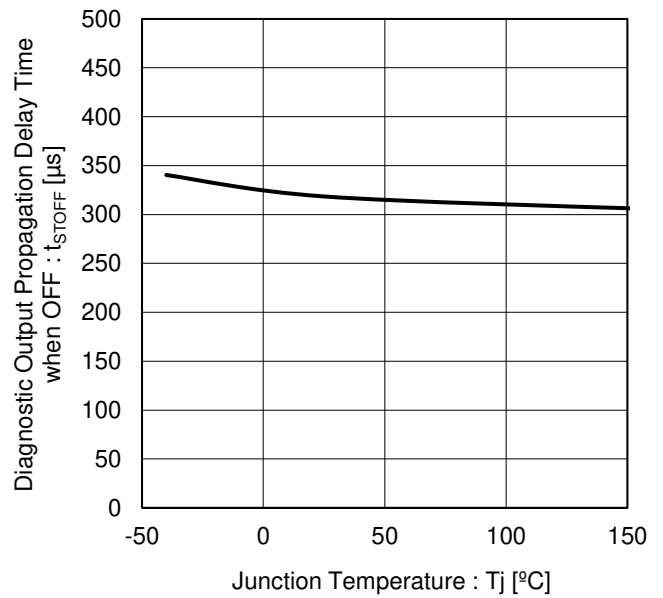

Figure 26. Diagnostic Output Propagation Delay Time when OFF vs Junction Temperature

Typical Performance Curves - continued

(Unless otherwise specified $V_{BB} = 14\text{ V}$, $V_{IN} = 5\text{ V}$, $T_j = 25\text{ }^\circ\text{C}$)

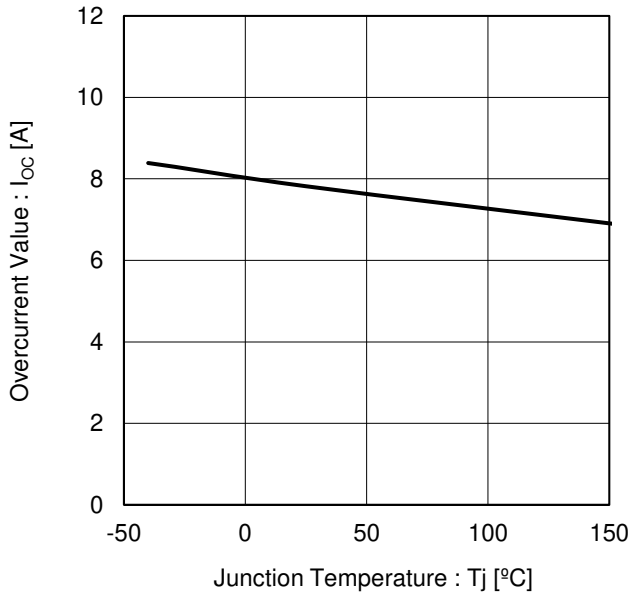

Figure 27. Overcurrent Value vs Junction Temperature

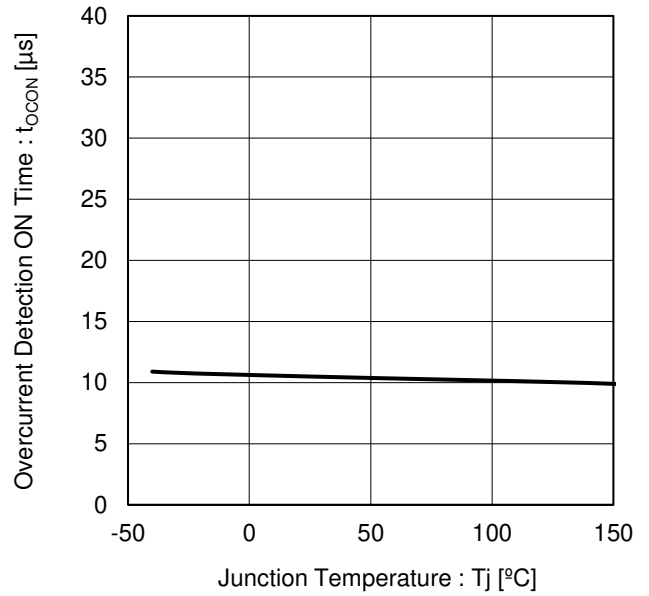

Figure 28. Overcurrent Detection ON Time vs Junction Temperature

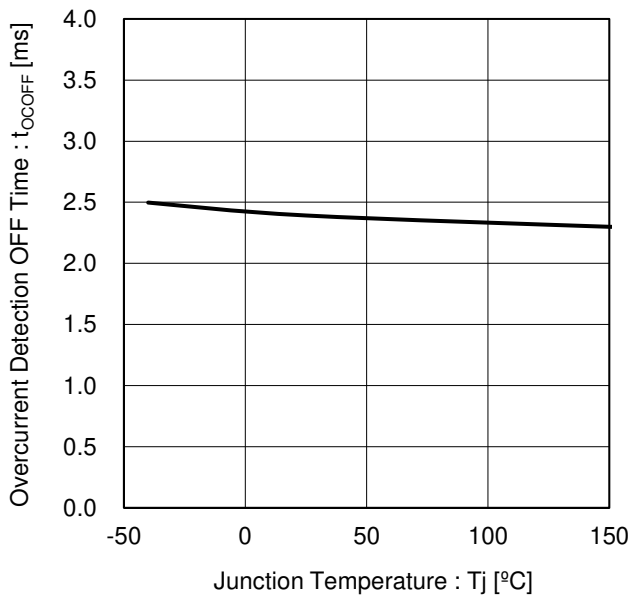

Figure 29. Overcurrent Detection OFF Time vs Junction Temperature

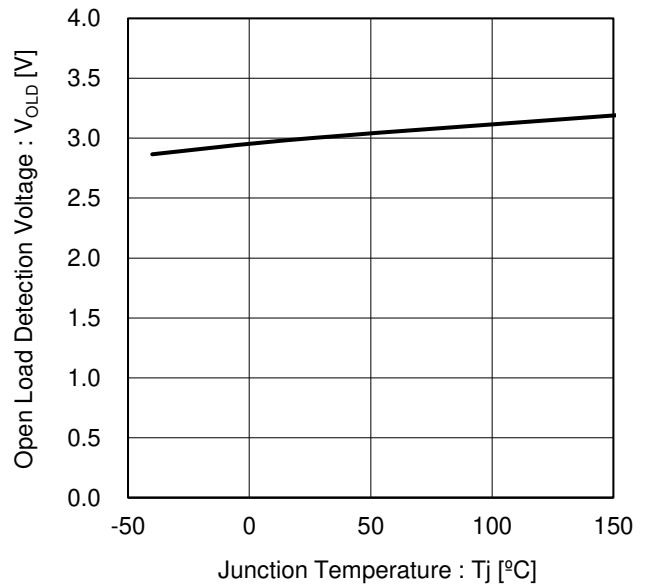

Figure 30. Open Load Detection Voltage vs Junction Temperature

Measurement Circuits

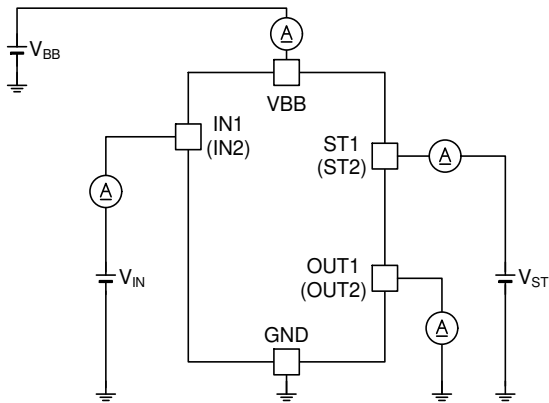

Figure 31. Standby Current
 Low Level Input Current
 Output Leak Current
 Diagnostic Output Leak Current

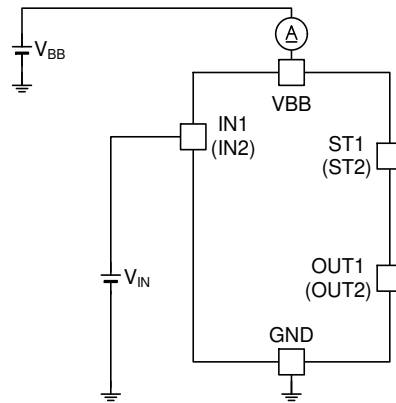

Figure 32. Operating Current

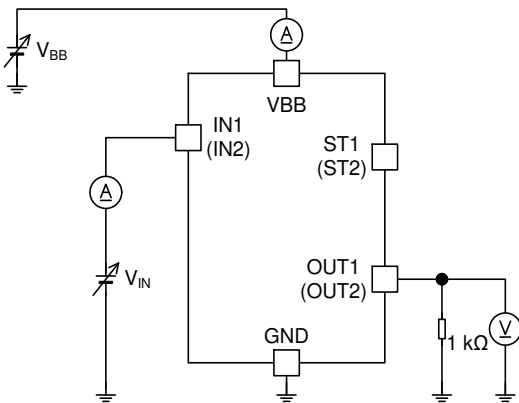

Figure 33. UVLO Detection / Hysteresis Voltage
 High / Low Level Input Voltage
 Input Hysteresis Voltage
 High Level Input Current
 Thermal Shutdown Detection
 / Release / Hysteresis Temperature

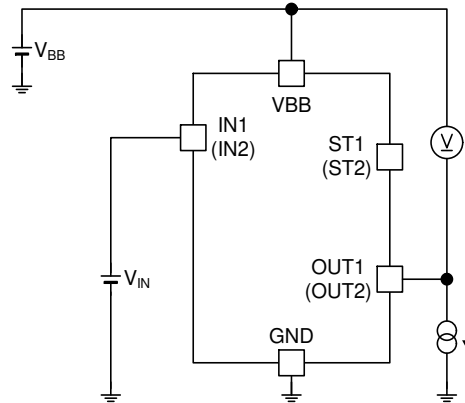

Figure 34. Output ON Resistance
 Output Clamp Voltage

Measurement Circuits - continued

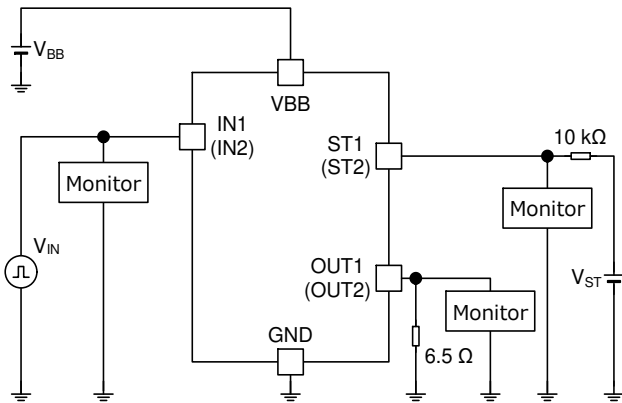

Figure 35. Output Slew Rate when ON / OFF
Output Propagation Delay Time when ON / OFF
Diagnostic Output Propagation Delay Time when ON

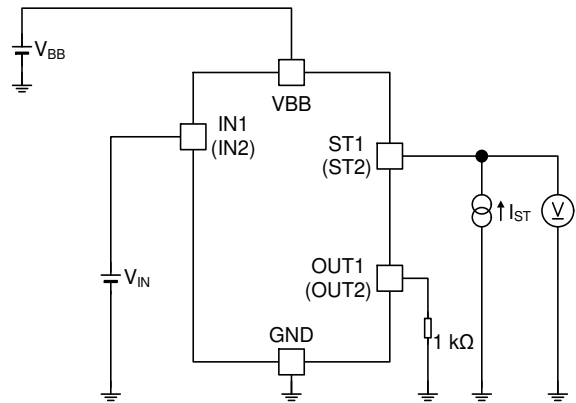

Figure 36. Diagnostic Output Low Voltage

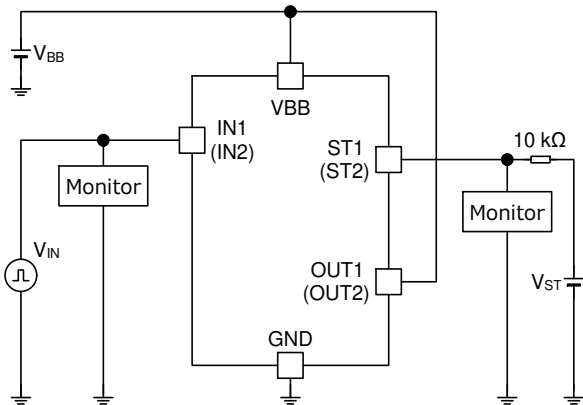

Figure 37. Diagnostic Output Propagation Delay Time when OFF

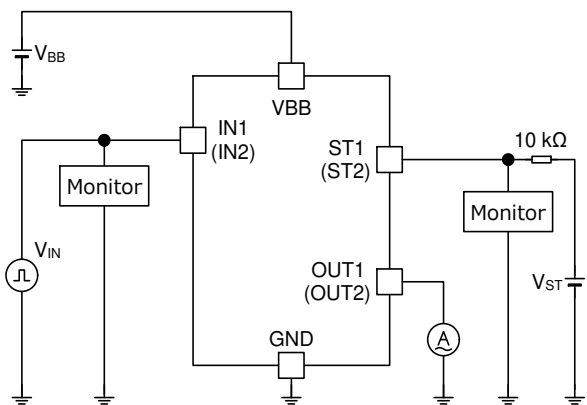

Figure 38. Overcurrent Value
Overcurrent Detection ON / OFF Time

Measurement Circuits - continued

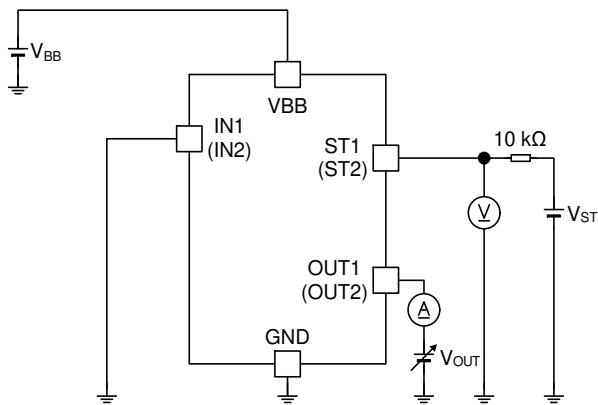

Figure 39. Open Load Detection Voltage
Open Load Detection Sink Current

Measurement Conditions for Time Items

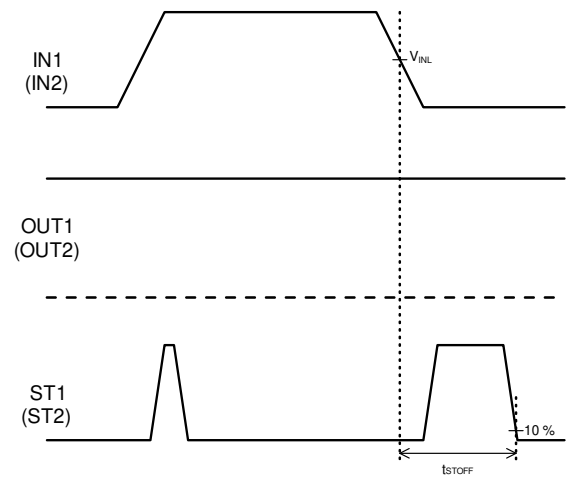
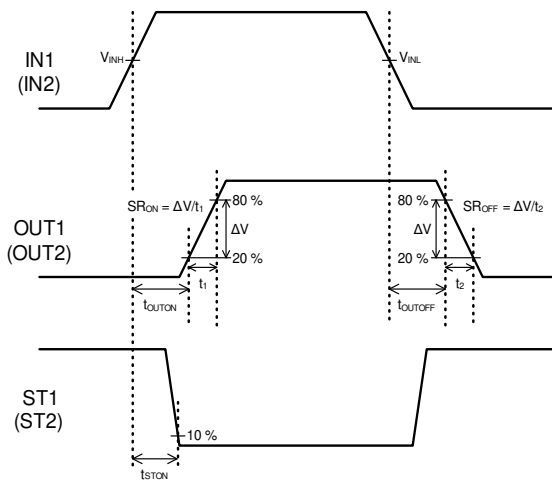

Figure 40. Output Slew Rate when ON / OFF
 Output Propagation Delay Time when ON / OFF
 Diagnostic Output Propagation Delay Time when ON

Figure 41. Diagnostic Output Propagation Delay Time when OFF

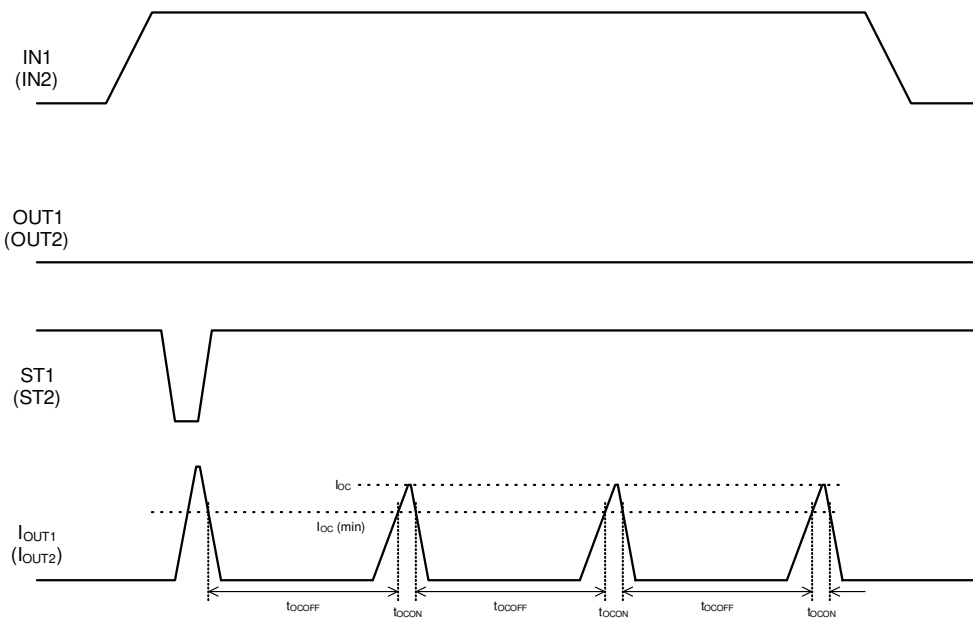

Figure 42. Overcurrent Value
 Overcurrent Detection ON / OFF Time

Timing Chart

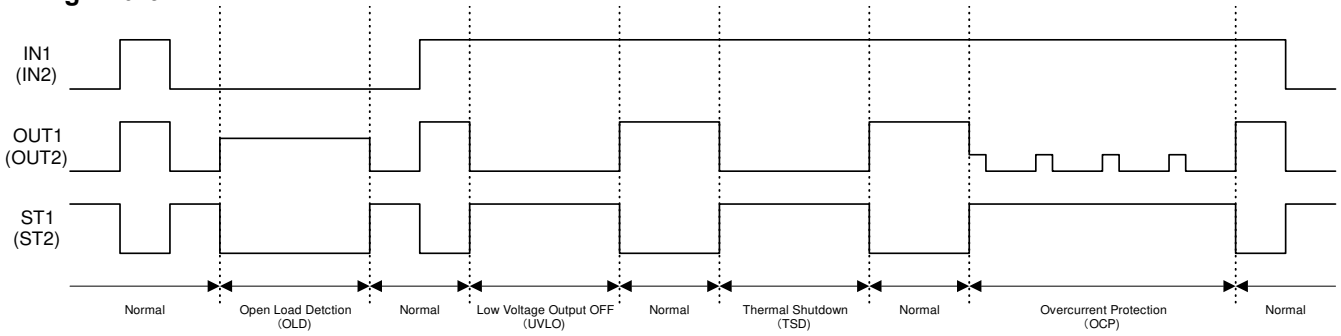

Figure 43. Timing Chart

Description of Blocks

1. Protection Functions

Table 1. Detection and Release Conditions and Diagnostic Output of Each Protection Function^(Note 1)

Mode		Detection / Release Conditions	Input Voltage V _{INx}	Diagnostic Output V _{STx}
Normal Condition	Standby	-	Low	High
	Operating	-	High	Low
Open Load Detect (OLD)		Detect V _{OUTx} ≥ 3.0 V (Typ)	Low	Low
		Release V _{OUTx} ≤ 2.2 V (Typ)	Low	High
Under Voltage Lockout (UVLO)		Detect V _{BB} ≤ 5.0 V (Max)	High	High
		Release V _{BB} ≥ 6.0 V (Max)	High	Low
Thermal Shutdown Protection (TSD) ^(Note 2)		Detect T _j ≥ 185 °C (Typ)	High	High
		Release T _j ≤ 175 °C (Typ)	High	Low
Overcurrent Protection (OCP)		Detect I _{OUTx} ≥ 6 A (Typ)	High	High
		Release I _{OUTx} < 6 A (Typ)	High	Low

(Note 1) x = 1, 2 and this is the same for x in the following sentence.

(Note 2) Thermal shutdown is automatically restored to normal operation.

This IC has a built-in protection detection function as mentioned above and outputs the condition with diagnostic output pin STx.

In normal condition, when input voltage V_{INx} is switched from Low to High, diagnostic output V_{STx} turns from High to Low. Inversely, when V_{INx} is switched from High to Low, V_{STx} turns from Low to High.

In protection function detected condition, V_{STx} is High when V_{INx} is High, and V_{STx} is Low when V_{INx} is Low. And after detecting protection function, this IC self-restarts and operation becomes normal if above release condition is satisfied.

2. Overcurrent Protection (Output ground fault detection)

This IC has a built-in hiccup mode overcurrent protection function. When the output pin (OUTx) outputs overcurrent, the output of Channel x is turned off and diagnostic output V_{STx} becomes High. After Overcurrent Detection OFF Time (t_{ocOFF}) from turn-off, output self-restarts and operation becomes normal if overcurrent doesn't flow. When overcurrent flows after the self-restart, output is turned off again. So, if the condition that causes overcurrent continues, output repeats ON and OFF periodically. And in this time V_{STx} keeps High.

And output current can exceed Overcurrent Value I_{oc} depending on the condition of impedance connected to V_{BB}, OUT pins.

3. Thermal Shutdown Protection

This IC has a built-in thermal shutdown protection function. When the chip temperature of POWER-MOS unit for Channel x in this IC exceeds 185 °C (Typ), the output of Channel x is turned OFF and diagnostic output V_{STx} becomes High.

When the chip temperature of POWER-MOS unit for Channel x goes below 175 °C (Typ), output self-restarts and operation becomes normal.

Description of Blocks - continued

4. Open Load Detection

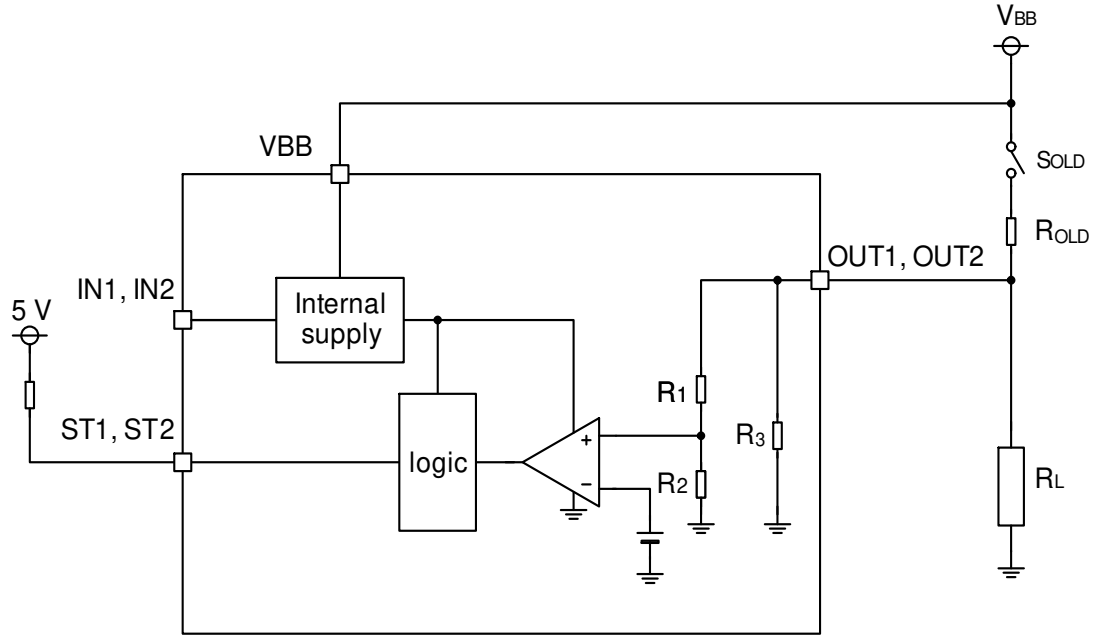

Figure 44. Open Load Detection Block Diagram

This IC has a built-in Open Load Detection function. By connecting an external resistance R_{OLD} between power supply pin (V_{BB}) and output pin ($OUTx$), when output load (R_L) is disconnected during input voltage V_{INx} is Low, diagnostic output V_{STx} becomes Low.

To reduce the standby current of the system, inserting a switch S_{OLD} is recommended.

The value of R_{OLD} is decided based on below formula.

$$R_{OLD} < V_{BBMIN} \times 37.5 \times 10^3 - 150 \times 10^3 \text{ } [\Omega]$$

$$\left(= V_{BBMIN} \times \frac{R_{MIN}}{V_{OLDMAX}} - R_{MIN} \text{ } [\Omega] \right)$$

Where:

V_{BBMIN} is the minimum value of power supply voltage (V_{BB}).

V_{OLDMAX} is the maximum value of Open Load Detection Voltage (V_{OLD}).

R_{MIN} is the minimum value of combined resistance of internal resistors R_1 , R_2 and R_3 .

Description of Blocks - continued

5. Other Protection

5.1 GND Open Protection

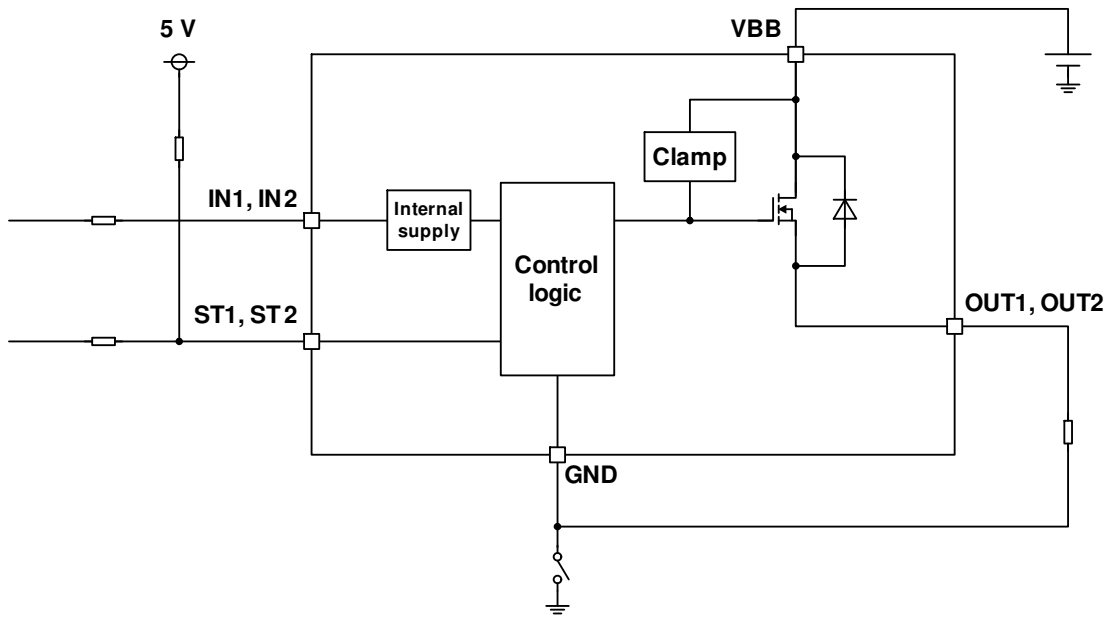

Figure 45. GND Open Protection Block Diagram

When GND of the IC is open, the output is switched OFF regardless of the input voltage V_{INx} . However, diagnostic output V_{STx} is not flagged. The active clamp operates when GND become open during driving inductive load.

5.2 MCU I/O Protection

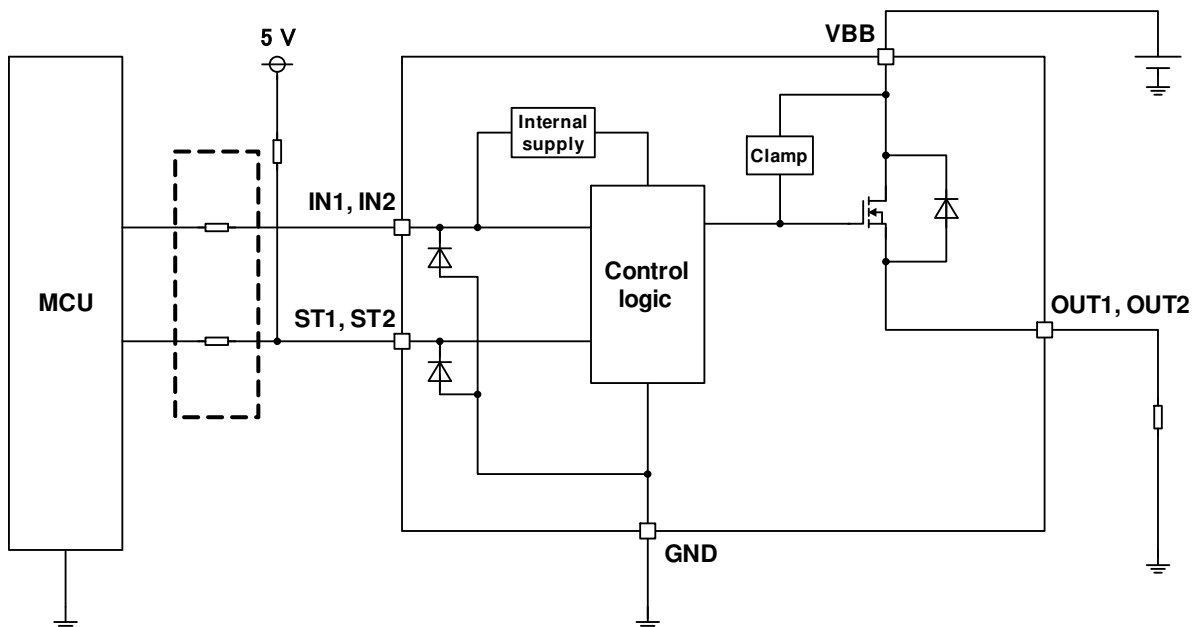
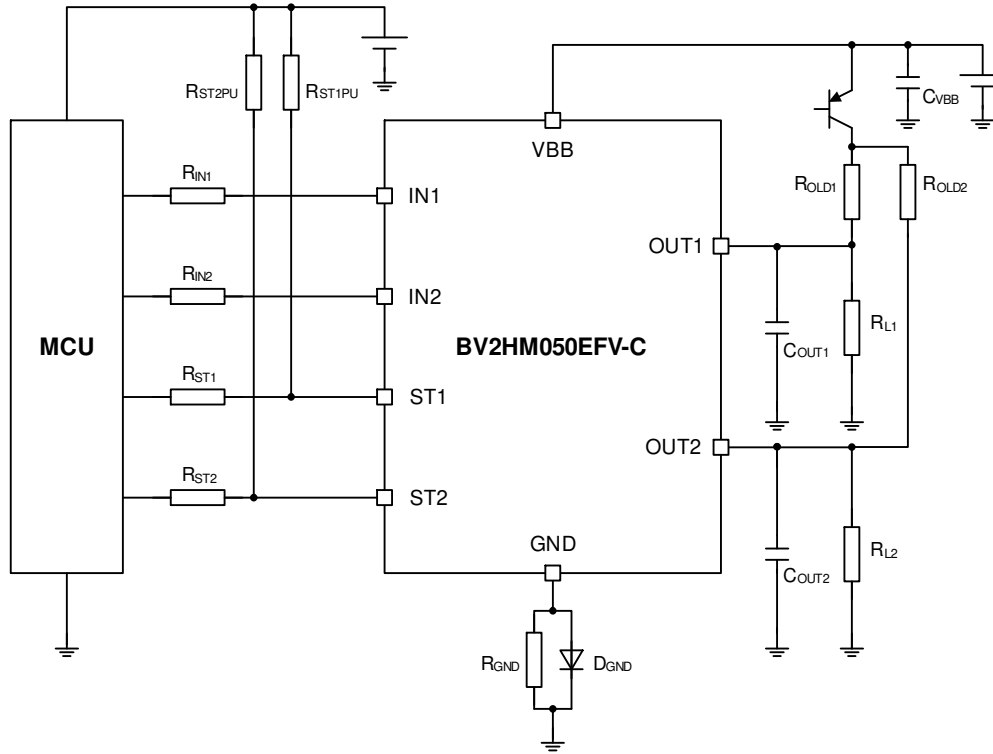

Figure 46. MCU I/O Protection Diagram

Negative surge voltage to input pin (IN1, IN2) or diagnostic output pin (ST1, ST2) may cause damage to the MCU's I/O pins. In order to prevent those damages, it is recommended to insert limiting resistors between IC pins and MCU.

Applications Example



Symbol	Value	Purpose
R_{IN1}, R_{IN2}	1 k Ω	Limit resistance for negative surge
R_{ST1}, R_{ST2}	1 k Ω	Limit resistance for negative surge
R_{ST1PU}, R_{ST2PU}	10 k Ω	Pull up resistance for diagnostic output The ST1 and ST2 pins are open drain output and pull up these pins to MCU power supply.
C_{VBB}	10 μ F	Filter for battery line voltage spike
R_{GND}	1 k Ω	Current limit resistance for reverse battery connection
D_{GND}	-	Protection diode for BV2HM050EFV-C against reverse battery connection
R_{OLD1}, R_{OLD2}	2 k Ω	Resistance for open load detection
C_{OUT1}, C_{OUT2}	1000 pF	Filter for radiation noise from outside of BV2HM050EFV-C
R_{L1}, R_{L2}	-	Output load

I/O Equivalence Circuits

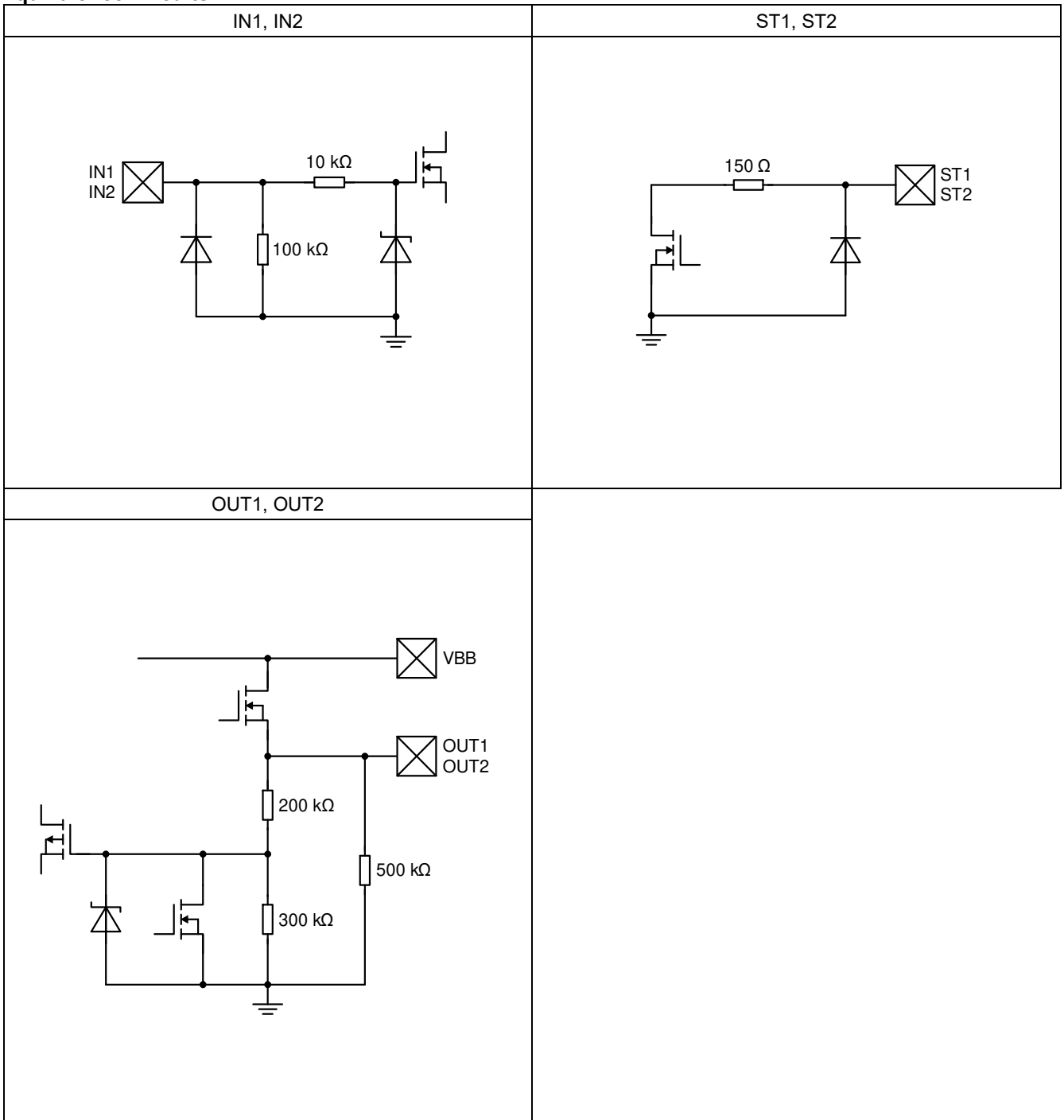

Operational Notes

1. Reverse Connection of Power Supply

Connecting the power supply in reverse polarity can damage the IC. Take precautions against reverse polarity when connecting the power supply, such as mounting an external diode between the power supply and the IC's power supply pins.

2. Power Supply Lines

Design the PCB layout pattern to provide low impedance supply lines. Furthermore, connect a capacitor to ground at all power supply pins. Consider the effect of temperature and aging on the capacitance value when using electrolytic capacitors.

3. Ground Voltage

Except for pins the output and the input of which were designed to go below ground, ensure that no pins are at a voltage below that of the ground pin at any time, even during transient condition.

4. Ground Wiring Pattern

When using both small-signal and large-current ground traces, the two ground traces should be routed separately but connected to a single ground at the reference point of the application board to avoid fluctuations in the small-signal ground caused by large currents. Also ensure that the ground traces of external components do not cause variations on the ground voltage. The ground lines must be as short and thick as possible to reduce line impedance.

5. Recommended Operating Conditions

The function and operation of the IC are guaranteed within the range specified by the recommended operating conditions. The characteristic values are guaranteed only under the conditions of each item specified by the electrical characteristics.

6. Inrush Current

When power is first supplied to the IC, it is possible that the internal logic may be unstable and inrush current may flow instantaneously due to the internal powering sequence and delays, especially if the IC has more than one power supply. Therefore, give special consideration to power coupling capacitance, power wiring, width of ground wiring, and routing of connections.

7. Testing on Application Boards

When testing the IC on an application board, connecting a capacitor directly to a low-impedance output pin may subject the IC to stress. Always discharge capacitors completely after each process or step. The IC's power supply should always be turned off completely before connecting or removing it from the test setup during the inspection process. To prevent damage from static discharge, ground the IC during assembly and use similar precautions during transport and storage.

8. Inter-pin Short and Mounting Errors

Ensure that the direction and position are correct when mounting the IC on the PCB. Incorrect mounting may result in damaging the IC. Avoid nearby pins being shorted to each other especially to ground, power supply and output pin. Inter-pin shorts could be due to many reasons such as metal particles, water droplets (in very humid environment) and unintentional solder bridge deposited in between pins during assembly to name a few.

9. Unused Input Pins

Input pins of an IC are often connected to the gate of a MOS transistor. The gate has extremely high impedance and extremely low capacitance. If left unconnected, the electric field from the outside can easily charge it. The small charge acquired in this way is enough to produce a significant effect on the conduction through the transistor and cause unexpected operation of the IC. So unless otherwise specified, unused input pins should be connected to the power supply or ground line.

10. Ceramic Capacitor

When using a ceramic capacitor, determine a capacitance value considering the change of capacitance with temperature and the decrease in nominal capacitance due to DC bias and others.

11. Thermal Shutdown Function (TSD)

This IC has a built-in thermal shutdown function that prevents heat damage to the IC. Normal operation should always be within the IC's maximum junction temperature rating. If however the rating is exceeded for a continued period, the junction temperature (T_j) will rise which will activate the TSD function that will turn OFF power output pins. When the T_j falls below the TSD threshold, the circuits are automatically restored to normal operation.

Note that the TSD function operates in a situation that exceeds the absolute maximum ratings and therefore, under no circumstances, should the TSD function be used in a set design or for any purpose other than protecting the IC from heat damage.

Operational Notes – continued**12. Over Current Protection Function (OCP)**

This IC incorporates an integrated overcurrent protection function that is activated when the load is shorted. This protection function is effective in preventing damage due to sudden and unexpected incidents. However, the IC should not be used in applications characterized by continuous operation or transitioning of the protection function.

13. Active Clamp Operation

The IC integrates the active clamp function to internally absorb the reverse energy E_L which is generated when the inductive load is turned off. When the active clamp operates, the thermal shutdown function does not work. Decide a load so that the reverse energy E_L is active clamp energy E_{AS} (refer to Figure 5. Active Clamp Energy vs Output Current) or under when inductive load is used.

14. Open Power Supply Pin

When the power supply pin (VBB) becomes open at ON (IN = High), the output is switched to OFF regardless of input voltage. If an inductive load is connected, the active clamp operates when VBB is open and becomes the same potential as that on the ground. At this time, the output voltage drops down to -50 V (Typ).

15. Open GND Pin

When the GND pin becomes open at ON (IN = High), the output is switched to OFF regardless of input voltage. If an inductive load is connected, the active clamp operates when the GND pin is open.

16. OUT Pin Voltage

Ensure that keep OUT pin voltage less than ($V_{BB} + 0.3\text{ V}$) at any time, even during transient condition. And ensure that OUT pin voltage is more than ($GND - 0.3\text{ V}$) when this IC is turned ON. Otherwise malfunction or other problems can occur.

17. Same Pin Connection

Connect all VBB pins, GND pins, OUT1 pins, OUT2 pins to same line respectively.

Ordering Information

B V 2 H M 0 5 0 E F V

C E 2

Part Number

Package
EFV: HTSSOP-B20

Product Rank
C: Automotive product
Packaging and Forming Specification
E2: Embossed tape and reel

Marking Diagram

HTSSOP-B20 (TOP VIEW)

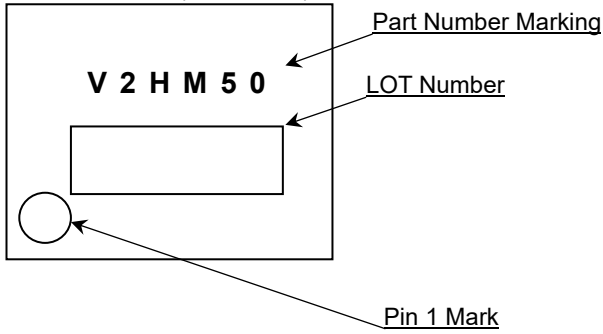

Physical Dimension and Packing Information

Package Name	HTSSOP-B20
--------------	------------

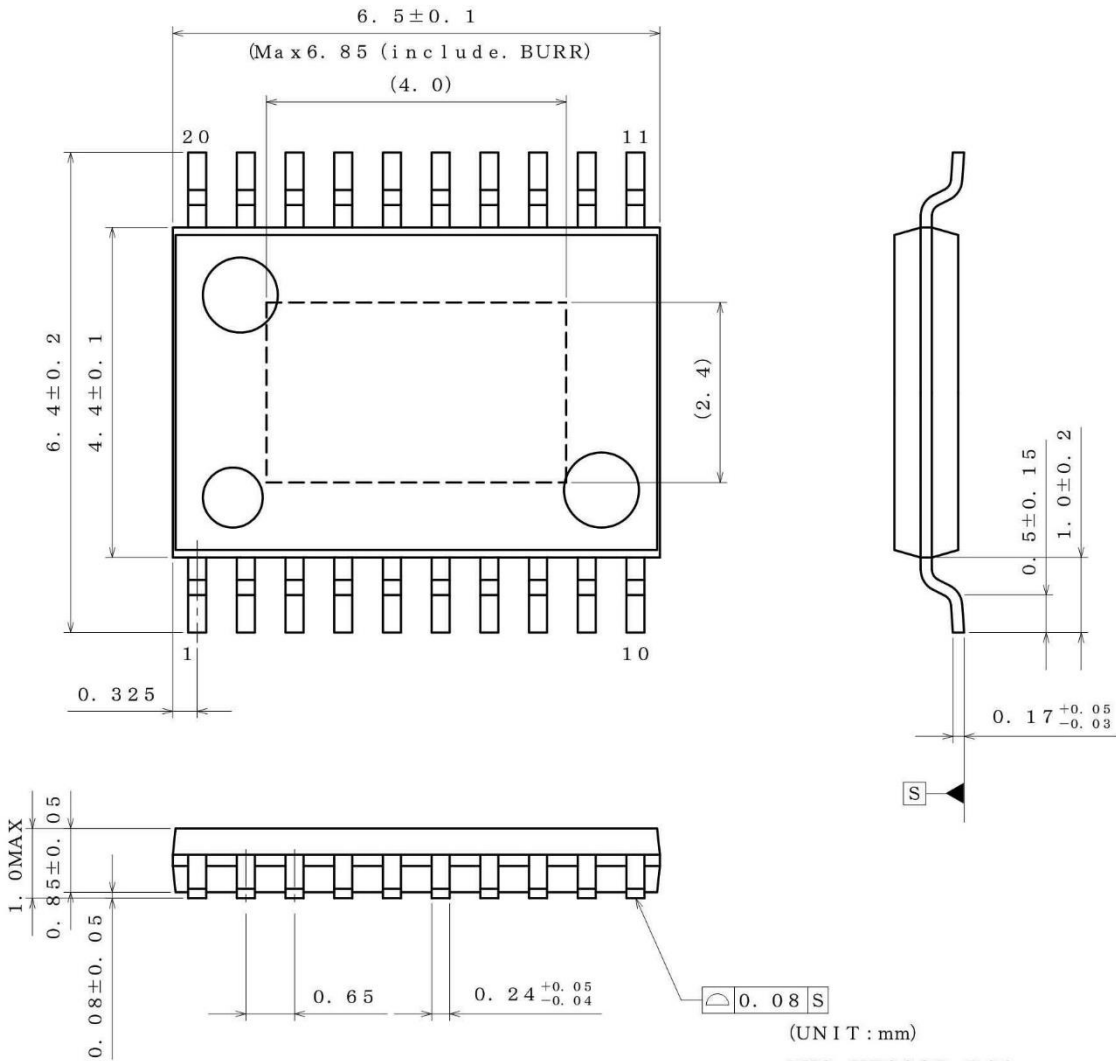

(UNIT : mm)
 PKG : HTSSOP-B20
 Drawing No. EX192-5002

< Tape and Reel Information >

Tape	Embossed carrier tape
Quantity	2500pcs
Direction of feed	E2 The direction is the pin 1 of product is at the upper left when you hold reel on the left hand and you pull out the tape on the right hand

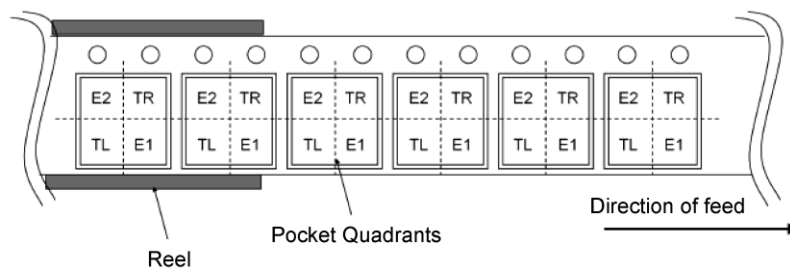

Revision History

Date	Revision	Changes
20.Jan.2022	001	New Release
31.Oct.2022	002	Page 27 Ordering Information The Description of "Part Number" is added.
31.Jan.2023	003	Page 5 Absolute Maximum Ratings Figure 5 is changed. Page 9 Thermal Resistance The vertical axis name in Figure 10 is corrected. Page 26 Operational Notes 14.Open Power Supply Pin The value of output clamp voltage is changed.

Notice

Precaution on using ROHM Products

1. If you intend to use our Products in devices requiring extremely high reliability (such as medical equipment ^(Note 1), aircraft/spacecraft, nuclear power controllers, etc.) and whose malfunction or failure may cause loss of human life, bodily injury or serious damage to property ("Specific Applications"), please consult with the ROHM sales representative in advance. Unless otherwise agreed in writing by ROHM in advance, ROHM shall not be in any way responsible or liable for any damages, expenses or losses incurred by you or third parties arising from the use of any ROHM's Products for Specific Applications.

(Note1) Medical Equipment Classification of the Specific Applications

JAPAN	USA	EU	CHINA
CLASS III	CLASS III	CLASS II b	CLASS III
CLASS IV		CLASS III	

2. ROHM designs and manufactures its Products subject to strict quality control system. However, semiconductor products can fail or malfunction at a certain rate. Please be sure to implement, at your own responsibilities, adequate safety measures including but not limited to fail-safe design against the physical injury, damage to any property, which a failure or malfunction of our Products may cause. The following are examples of safety measures:
 - [a] Installation of protection circuits or other protective devices to improve system safety
 - [b] Installation of redundant circuits to reduce the impact of single or multiple circuit failure
3. Our Products are not designed under any special or extraordinary environments or conditions, as exemplified below. Accordingly, ROHM shall not be in any way responsible or liable for any damages, expenses or losses arising from the use of any ROHM's Products under any special or extraordinary environments or conditions. If you intend to use our Products under any special or extraordinary environments or conditions (as exemplified below), your independent verification and confirmation of product performance, reliability, etc. prior to use, must be necessary:
 - [a] Use of our Products in any types of liquid, including water, oils, chemicals, and organic solvents
 - [b] Use of our Products outdoors or in places where the Products are exposed to direct sunlight or dust
 - [c] Use of our Products in places where the Products are exposed to sea wind or corrosive gases, including Cl₂, H₂S, NH₃, SO₂, and NO₂
 - [d] Use of our Products in places where the Products are exposed to static electricity or electromagnetic waves
 - [e] Use of our Products in proximity to heat-producing components, plastic cords, or other flammable items
 - [f] Sealing or coating our Products with resin or other coating materials
 - [g] Use of our Products without cleaning residue of flux (Exclude cases where no-clean type fluxes is used. However, recommend sufficiently about the residue.); or Washing our Products by using water or water-soluble cleaning agents for cleaning residue after soldering
 - [h] Use of the Products in places subject to dew condensation
4. The Products are not subject to radiation-proof design.
5. Please verify and confirm characteristics of the final or mounted products in using the Products.
6. In particular, if a transient load (a large amount of load applied in a short period of time, such as pulse, is applied, confirmation of performance characteristics after on-board mounting is strongly recommended. Avoid applying power exceeding normal rated power; exceeding the power rating under steady-state loading condition may negatively affect product performance and reliability.
7. De-rate Power Dissipation depending on ambient temperature. When used in sealed area, confirm that it is the use in the range that does not exceed the maximum junction temperature.
8. Confirm that operation temperature is within the specified range described in the product specification.
9. ROHM shall not be in any way responsible or liable for failure induced under deviant condition from what is defined in this document.

Precaution for Mounting / Circuit board design

1. When a highly active halogenous (chlorine, bromine, etc.) flux is used, the residue of flux may negatively affect product performance and reliability.
2. In principle, the reflow soldering method must be used on a surface-mount products, the flow soldering method must be used on a through hole mount products. If the flow soldering method is preferred on a surface-mount products, please consult with the ROHM representative in advance.

For details, please refer to ROHM Mounting specification

Precautions Regarding Application Examples and External Circuits

1. If change is made to the constant of an external circuit, please allow a sufficient margin considering variations of the characteristics of the Products and external components, including transient characteristics, as well as static characteristics.
2. You agree that application notes, reference designs, and associated data and information contained in this document are presented only as guidance for Products use. Therefore, in case you use such information, you are solely responsible for it and you must exercise your own independent verification and judgment in the use of such information contained in this document. ROHM shall not be in any way responsible or liable for any damages, expenses or losses incurred by you or third parties arising from the use of such information.

Precaution for Electrostatic

This Product is electrostatic sensitive product, which may be damaged due to electrostatic discharge. Please take proper caution in your manufacturing process and storage so that voltage exceeding the Products maximum rating will not be applied to Products. Please take special care under dry condition (e.g. Grounding of human body / equipment / solder iron, isolation from charged objects, setting of Ionizer, friction prevention and temperature / humidity control).

Precaution for Storage / Transportation

1. Product performance and soldered connections may deteriorate if the Products are stored in the places where:
 - [a] the Products are exposed to sea winds or corrosive gases, including Cl₂, H₂S, NH₃, SO₂, and NO₂
 - [b] the temperature or humidity exceeds those recommended by ROHM
 - [c] the Products are exposed to direct sunshine or condensation
 - [d] the Products are exposed to high Electrostatic
2. Even under ROHM recommended storage condition, solderability of products out of recommended storage time period may be degraded. It is strongly recommended to confirm solderability before using Products of which storage time is exceeding the recommended storage time period.
3. Store / transport cartons in the correct direction, which is indicated on a carton with a symbol. Otherwise bent leads may occur due to excessive stress applied when dropping of a carton.
4. Use Products within the specified time after opening a humidity barrier bag. Baking is required before using Products of which storage time is exceeding the recommended storage time period.

Precaution for Product Label

A two-dimensional barcode printed on ROHM Products label is for ROHM's internal use only.

Precaution for Disposition

When disposing Products please dispose them properly using an authorized industry waste company.

Precaution for Foreign Exchange and Foreign Trade act

Since concerned goods might be fallen under listed items of export control prescribed by Foreign exchange and Foreign trade act, please consult with ROHM in case of export.

Precaution Regarding Intellectual Property Rights

1. All information and data including but not limited to application example contained in this document is for reference only. ROHM does not warrant that foregoing information or data will not infringe any intellectual property rights or any other rights of any third party regarding such information or data.
2. ROHM shall not have any obligations where the claims, actions or demands arising from the combination of the Products with other articles such as components, circuits, systems or external equipment (including software).
3. No license, expressly or implied, is granted hereby under any intellectual property rights or other rights of ROHM or any third parties with respect to the Products or the information contained in this document. Provided, however, that ROHM will not assert its intellectual property rights or other rights against you or your customers to the extent necessary to manufacture or sell products containing the Products, subject to the terms and conditions herein.

Other Precaution

1. This document may not be reprinted or reproduced, in whole or in part, without prior written consent of ROHM.
2. The Products may not be disassembled, converted, modified, reproduced or otherwise changed without prior written consent of ROHM.
3. In no event shall you use in any way whatsoever the Products and the related technical information contained in the Products or this document for any military purposes, including but not limited to, the development of mass-destruction weapons.
4. The proper names of companies or products described in this document are trademarks or registered trademarks of ROHM, its affiliated companies or third parties.

General Precaution

1. Before you use our Products, you are requested to carefully read this document and fully understand its contents. ROHM shall not be in any way responsible or liable for failure, malfunction or accident arising from the use of any ROHM's Products against warning, caution or note contained in this document.
2. All information contained in this document is current as of the issuing date and subject to change without any prior notice. Before purchasing or using ROHM's Products, please confirm the latest information with a ROHM sales representative.
3. The information contained in this document is provided on an "as is" basis and ROHM does not warrant that all information contained in this document is accurate and/or error-free. ROHM shall not be in any way responsible or liable for any damages, expenses or losses incurred by you or third parties resulting from inaccuracy or errors of or concerning such information.