

9.5 GHz Surface Mount Low-Pass Filter

L095XG9S

DESCRIPTION

DLI introduces its new high frequency surface mountable catalog low pass filters. These LPF's incorporate DLI's high dielectric ceramic materials which provide small size and minimal performance variation over temperature. The catalog LPF's are offered in a variety of frequency bands, which offers a drop in solution for high frequency attenuation.

FEATURES

- Small Size
- Fully Shielded Component
- Solder Surface Mountable
- Moisture Sensitivity Level: MSL1
- Frequency Stable over Temperature
- Operating & Storage Temp: -55°C to +125°C
- Characteristic Impedance: 50Ω

SPECIFICATIONS*

Parameter	Frequency (GHz)	Min	Typ.	Max
Insertion Loss* (dB)	DC - 9		0.75	2.0
Return Loss (dB)		15	22	
High side Rejection (dB)	11.5 - 32	30		
CW Input Power (W)**	DC - 9			12.5
$\theta_{JC} \left(\frac{^{\circ}C}{W} \right)$	-		6	
Size (LxWxH)		0.220 x 0.140 x 0.118 in 5.59 x 3.56 x 3.00 mm		

*Electrical specifications based on typical probed performance at room temperature. Insertion loss shall vary ± 0.5 dB over temperature.

**Power rating assumes the component will be mounted to a PCB with good thermally conducting ground via's as outlined in the recommended PCB layout that are connected to an adequate heat sink. Max power is based on 125°C base temperature.

Typical Measured Performance

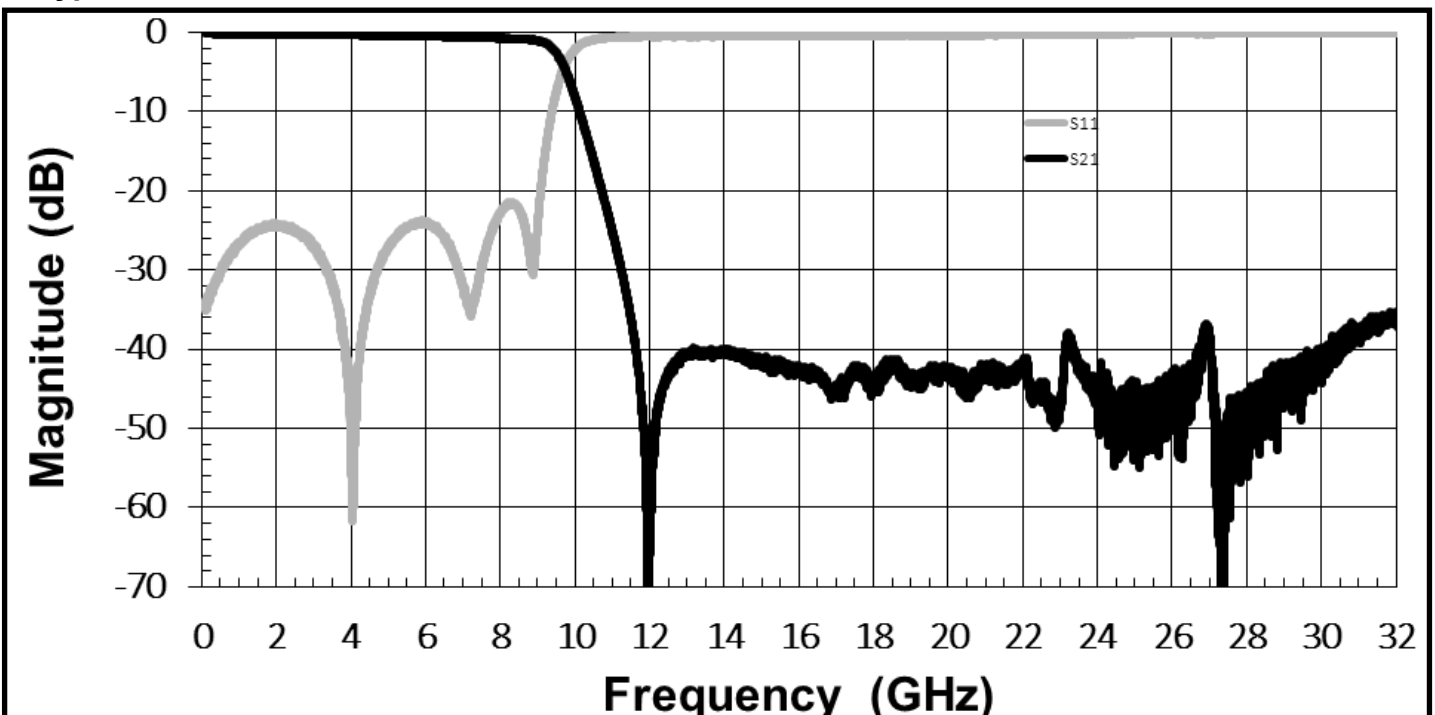

9.5 GHz Surface Mount Low-Pass Filter

L095XG9S

Physical Dimensions

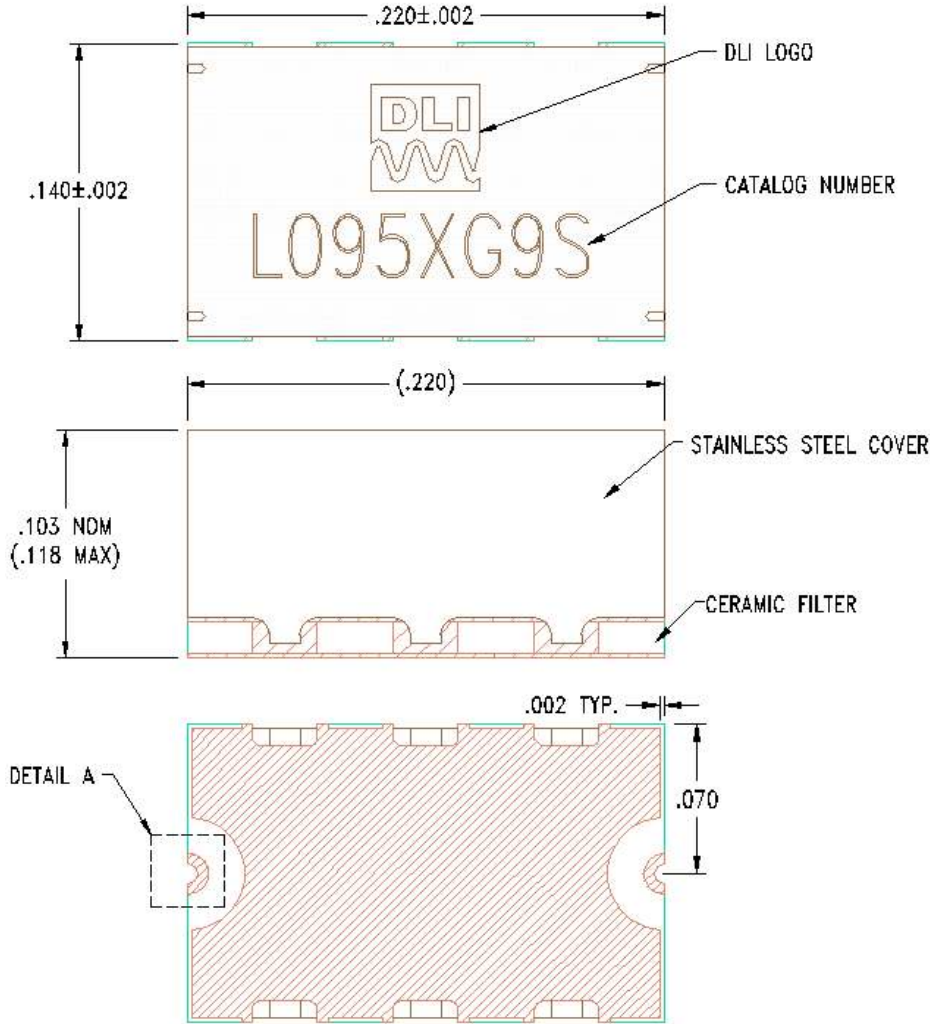

Units = inches

Packaging and Ordering information:

To request Tape and Reel packaging, please order part number **L095XG9S-T**

DETAIL A
(2 PLACES)

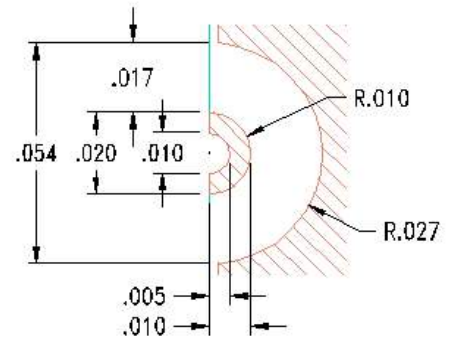

Recommended PCB Layout

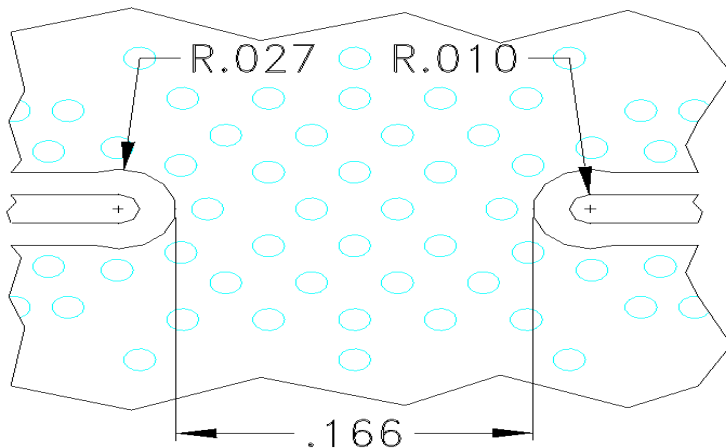

- 50Ω trace dimensions are application specific.
- Ensure adequate grounding beneath the filter.

