

## Charge Pump DC-to-DC Converter

### Features

- Wide Operating Range
  - 3V to 18V
- Increased Output Current (40mA)
- Pin Compatible with ICL7662/SI7661/TC7660/LTC1044
- No External Diodes Required
- Low Output Impedance @  $I_L = 20\text{mA}$ 
  - $40\Omega$  Typ.
- No Low-Voltage Terminal Required
- CMOS Construction
- Available in 8-Pin PDIP and 8-Pin Cerdip Packages

### Applications

- Laptop Computers
- Disk Drives
- Process Instrumentation
- $\mu\text{P}$ -based Controllers

### Device Selection Table

Part Number	Package	Operating Temp. Range
TC7662ACPA	8-Pin PDIP	0°C to +70°C
TC7662AEPA	8-Pin PDIP	-40°C to +85°C
TC7662AIJA	8-Pin Cerdip	-25°C to +85°C
TC7662AMJA	8-Pin Cerdip	-55°C to +125°C

### Package Type

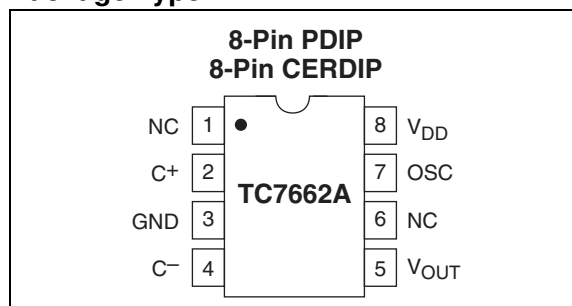

### General Description

The TC7662A is a pin-compatible upgrade to the industry standard TC7660 charge pump voltage converter. It converts a +3V to +18V input to a corresponding -3V to -18V output using only two low-cost capacitors, eliminating inductors and their associated cost, size and EMI. In addition to a wider power supply input range (3V to 18V versus 1.5V to 10V for the TC7660), the TC7662A can source output currents as high as 40mA. The on-board oscillator operates at a nominal frequency of 12kHz. Operation below 12kHz (for lower supply current applications) is also possible by connecting an external capacitor from OSC to ground.

The TC7662A directly is recommended for designs requiring greater output current and/or lower input/output voltage drop. It is available in 8-pin PDIP and Cerdip packages in commercial and extended temperature ranges.

# TC7662A

## Functional Block Diagram

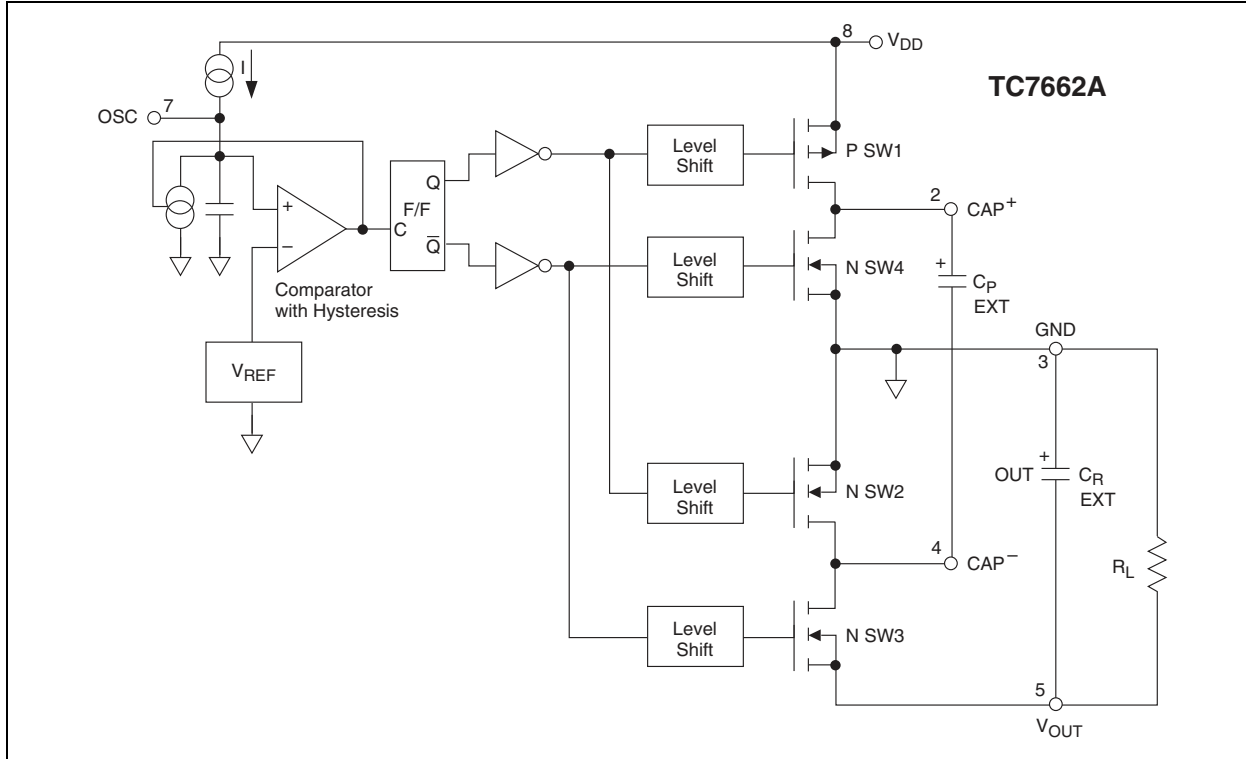

## 1.0 ELECTRICAL CHARACTERISTICS

### Absolute Maximum Ratings\*

Supply Voltage $V_{DD}$ to GND.....	+18V
Input Voltage (Any Pin) .....	$(V_{DD} + 0.3)$ to $(V_{SS} - 0.3)$
Current into Any Pin.....	10mA
Output Short Circuit .....	Continuous (at 5.5V Input)
ESD Protection .....	$\pm 2000V$
Package Power Dissipation ( $T_A \leq 70^\circ C$ )	
8-Pin CERDIP .....	800mW
8-Pin PDIP .....	730mW
Package Thermal Resistance	
CPA, EPA $\theta_{JA}$ .....	140°C/W
IJA, MJA $\theta_{JA}$ .....	90°C/W
Operating Temperature Range	
C Suffix.....	0°C to +70°C
I Suffix .....	-25°C to +85°C
E Suffix.....	-40°C to +85°C
M Suffix .....	-55°C to +125°C
Storage Temperature Range.....	-65°C to +150°C

Stresses above those listed under "Absolute Maximum Ratings" may cause permanent damage to the device. These are stress ratings only and functional operation of the device at these or any other conditions above those indicated in the operation sections of the specifications is not implied. Exposure to Absolute Maximum Rating conditions for extended periods may affect device reliability.

### TC7662A ELECTRICAL SPECIFICATIONS

Electrical Characteristics: $V_{DD} = 15V$ , $T_A = +25^\circ C$ , Test circuit (Figure 3-1) unless otherwise noted.						
Symbol	Parameter	Min	Typ	Max	Units	Test Conditions
$V_{DD}$	Supply Voltage	3	—	18	V	
$I_S$	Supply Current	—	—	—	$\mu A$	$R_L = \infty$ $V_{DD} = +15V$ $0^\circ C \leq T_A \leq +70^\circ C$ $-55^\circ C \leq T_A \leq +125^\circ C$
		—	510	700		
		—	560	—		
		—	650	—		$V_{DD} = +5V$
		—	190	—		$0^\circ C \leq T_A \leq +70^\circ C$
		—	210	—		$-55^\circ C \leq T_A \leq +125^\circ C$
		—	210	—		
$R_O$	Output Source Resistance	—	40	50	$\Omega$	$I_L = 20mA$ , $V_{DD} = +15V$ $I_L = 40mA$ , $V_{DD} = +15V$ $I_L = 3mA$ , $V_{DD} = +5V$
		—	50	60		
		—	100	125		
$F_{OSC}$	Oscillator Frequency	—	12	—	kHz	
$P_{EFF}$	Power Efficiency	93	97	—	%	$V_{DD} = +15V$ $R_L = 2k\Omega$
		—	—	—		
$V_{EFF}$	Voltage Efficiency	99	99.9	—	%	$V_{DD} = +15V$ $R_L = \infty$
		—	—	—		Over operating temperature range.
		96	—	—		

# TC7662A

---

---

## 2.0 PIN DESCRIPTIONS

The descriptions of the pins are listed in Table 2-1.

**TABLE 2-1: PIN FUNCTION TABLE**

Pin No. (8-Pin PDIP, CERDIP)	Symbol	Description
1	NC	No connection.
2	C <sup>+</sup>	Charge pump capacitor positive terminal.
3	GND	Ground terminal.
4	C <sup>-</sup>	Charge pump capacitor negative terminal.
5	V <sub>OUT</sub>	Output voltage.
6	NC	No connection.
7	OSC	Oscillator control input. Bypass with an external capacitor to slow the oscillator.
8	V <sub>DD</sub>	Power supply positive voltage input.

## 3.0 DETAILED DESCRIPTION

The TC7662A is a capacitive charge pump (sometimes called a switched-capacitor circuit), where four MOSFET switches control the charge and discharge of a capacitor.

The functional block diagram shows how the switching action works. SW1 and SW2 are turned on simultaneously, charging  $C_P$  to the supply voltage,  $V_{DD}$ . This assumes that the ON resistance of the MOSFETs in series with the capacitor produce a charging time (3 time constants) less than the ON time provided by the oscillator frequency, as shown:

$$3 (R_{DS(ON)} C_P) < C_P / (0.5 f_{OSC}).$$

In the next cycle, SW1 and SW2 are turned OFF and, after a very short interval with all switches OFF (preventing large currents from occurring due to cross conduction), SW3 and SW4 are turned ON. The charge in  $C_P$  is then transferred to  $C_R$ , but with the polarity inverted. In this way, a negative voltage is derived.

An oscillator supplies pulses to a flip-flop that is fed to a set of level shifters. These level shifters then drive each set of switches at one-half the oscillator frequency.

The oscillator has a pin that controls the frequency of oscillation. Pin 7 can have a capacitor added that is connected to ground. This will lower the frequency of the oscillator by adding capacitance to the internal timing capacitor of the TC7662A. (See Typical Characteristics – Oscillator Frequency vs.  $C_{OSC}$ .)

**FIGURE 3-1: TC7662A TEST CIRCUIT**

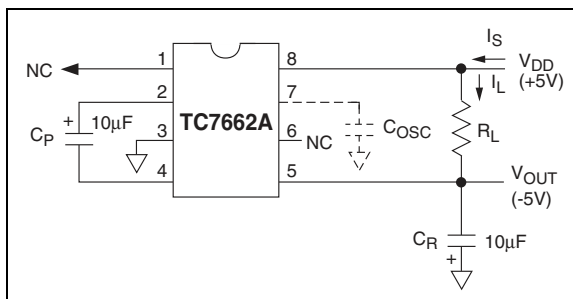

## 3.1 Theoretical Power Efficiency Considerations

In theory, a voltage converter can approach 100% efficiency if certain conditions are met:

1. The drive circuitry consumes minimal power.
2. The output switches have extremely low ON resistance and virtually no offset.
3. The impedances of the pump and reservoir capacitors are negligible at the pump frequency.

The TC7662A approaches these conditions for negative voltage conversion if large values of  $C_P$  and  $C_R$  are used.

**Note:** Energy is lost only in the transfer of charge between capacitors if a change in voltage occurs.

The energy lost is defined by:

$$E = 1/2 C_P (V_1^2 - V_2^2)$$

$V_1$  and  $V_2$  are the voltages on  $C_P$  during the pump and transfer cycles. If the impedances of  $C_P$  and  $C_R$  are relatively high at the pump frequency (refer to Figure 3-1), compared to the value of  $R_L$ , there will be a substantial difference in voltages  $V_1$  and  $V_2$ . Therefore, it is desirable not only to make  $C_R$  as large as possible to eliminate output voltage ripple, but also to employ a correspondingly large value for  $C_P$  in order to achieve maximum efficiency of operation.

## 3.2 Dos and Don'ts

- Do not exceed maximum supply voltages.
- Do not short circuit the output to  $V^+$  supply for voltages above 5.5V for extended periods; however, transient conditions including start-up are okay.
- When using polarized capacitors in the inverting mode, the + terminal of  $C_P$  must be connected to pin 2 of the TC7662A and the + terminal of  $C_R$  must be connected to GND (pin 3).
- If the voltage supply driving the TC7662A has a large source impedance (25-30 ohms), then a 2.2µF capacitor from pin 8 to ground may be required to limit the rate of rise of the input voltage to less than 2V/µsec.

# TC7662A

## 4.0 TYPICAL APPLICATIONS

### 4.1 Simple Negative Voltage Converter

The majority of applications will undoubtedly utilize the TC7662A for generation of negative supply voltages. Figure 4-1 shows typical connections to provide a negative supply where a positive supply of +3V to +18V is available.

**FIGURE 4-1: SIMPLE NEGATIVE CONVERTER AND ITS OUTPUT EQUIVALENT**

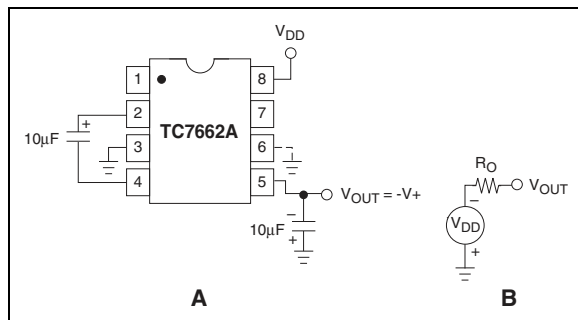

The output characteristics of the circuit in Figure 4-1 are those of a nearly ideal voltage source in series with a resistance as shown in Figure 4-1b. The voltage source has a value of  $-(V_{DD})$ . The output impedance ( $R_O$ ) is a function of the ON resistance of the internal MOS switches (shown in the Functional Block Diagram), the switching frequency, the value of  $C_P$  and  $C_R$ , and the ESR (equivalent series resistance) of  $C_P$  and  $C_R$ . A good first order approximation for  $R_O$  is:

$$R_O \cong 2(R_{SW1} + R_{SW2} + ESR_{CP}) + 2(R_{SW3} + R_{SW4} + ESR_{CR}) + \frac{1}{f_{PUMP} \times C_P} + ESR_{CR}$$

( $f_{PUMP} = \frac{f_{OSC}}{2}$ ,  $R_{SWX} =$  MOSFET switch resistance)

Combining the four  $R_{SWX}$  terms as  $R_{SW}$ , we see that:

$$R_O \cong 2 \times R_{SW} + \frac{1}{f_{PUMP} \times C_P} + 4 \times ESR_{CP} + ESR_{CR}$$

$R_{SW}$ , the total switch resistance, is a function of supply voltage and temperature (See Section 5.0, Typical Characteristics "Output Source Resistance" graphs), typically  $23\Omega$  at  $+25^\circ\text{C}$  and 5V. Careful selection of  $C_P$  and  $C_R$  will reduce the remaining terms, minimizing the output impedance. High value capacitors will reduce the  $1/(f_{PUMP} \times C_P)$  component, and low ESR capacitors will lower the ESR term. Increasing the oscillator frequency will reduce the  $1/(f_{PUMP} \times C_P)$  term, but may have the side effect of a net increase in output impedance when  $C_P > 10\mu\text{F}$  and there is not enough time to fully charge the capacitors every cycle. In a typical application when  $f_{OSC} = 12\text{kHz}$  and  $C = C_P = C_R = 10\mu\text{F}$ :

$$R_O \cong 2 \times 23 + \frac{1}{(5 \times 12^3 \times 10 \times 10^{-6})} + 4 \times ESR_{CP} + ESR_{CR}$$

$$R_O \cong (46 + 20 + 5 \times ESR_C)\Omega$$

Since the ESRs of the capacitors are reflected in the output impedance multiplied by a factor of 5, a high value could potentially swamp out a low  $1/(f_{PUMP} \times C_P)$  term, rendering an increase in switching frequency or filter capacitance ineffective. Typical electrolytic capacitors may have ESRs as high as  $10\Omega$ .

## 4.2 Output Ripple

ESR also affects the ripple voltage seen at the output. The total ripple is determined by 2 voltages, A and B, as shown in Figure 4-2. Segment A is the voltage drop across the ESR of  $C_R$  at the instant it goes from being charged by  $C_P$  (current flowing into  $C_R$ ) to being discharged through the load (current flowing out of  $C_R$ ). The magnitude of this current change is  $2 \times I_{OUT}$ , hence the total drop is  $2 \times I_{OUT} \times ESR_{CR}$  volts. Segment B is the voltage change across  $C_R$  during time  $t_2$ , the half of the cycle when  $C_R$  supplies current to the load. The drop at B is  $I_{OUT} \times t_2 / C_R$  volts. The peak-to-peak ripple voltage is the sum of these voltage drops:

$$V_{RIPPLE} \cong \left( \frac{1}{2 \times f_{PUMP} \times C_R} + 2 \times ESR_{CR} \times I_{OUT} \right)$$

**FIGURE 4-2: OUTPUT RIPPLE**

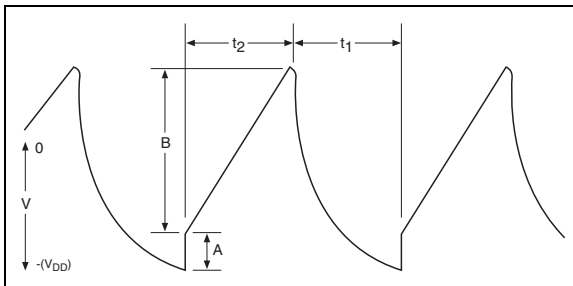

## 4.3 Paralleling Devices

Any number of TC7662A voltage converters may be paralleled to reduce output resistance (Figure 4-3). The reservoir capacitor,  $C_R$ , serves all devices, while each device requires its own pump capacitor,  $C_P$ . The resultant output resistance would be approximately:

$$R_{OUT} = \frac{R_{OUT} \text{ (of TC7662A)}}{n \text{ (number of devices)}}$$

## 4.4 Cascading Devices

The TC7662A may be cascaded as shown (Figure 4-4) to produce larger negative multiplication of the initial supply voltage. However, due to the finite efficiency of each device, the practical limit is 10 devices for light loads. The output voltage is defined by:

$$V_{OUT} = -n (V_{IN})$$

where  $n$  is an integer representing the number of devices cascaded. The resulting output resistance would be approximately the weighted sum of the individual TC7662A  $R_{OUT}$  values.

**FIGURE 4-3: PARALLELING DEVICES LOWERS OUTPUT IMPEDANCE**

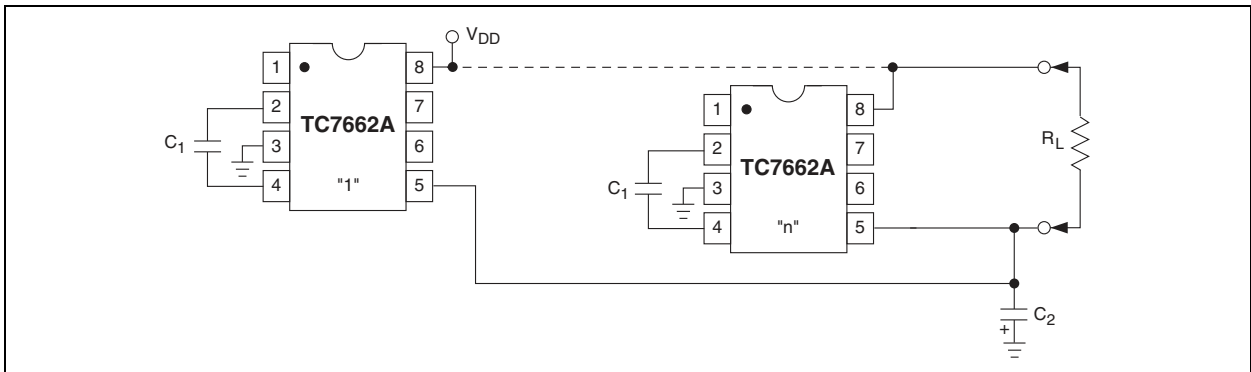

**FIGURE 4-4: INCREASED OUTPUT VOLTAGE BY CASCADING DEVICES**

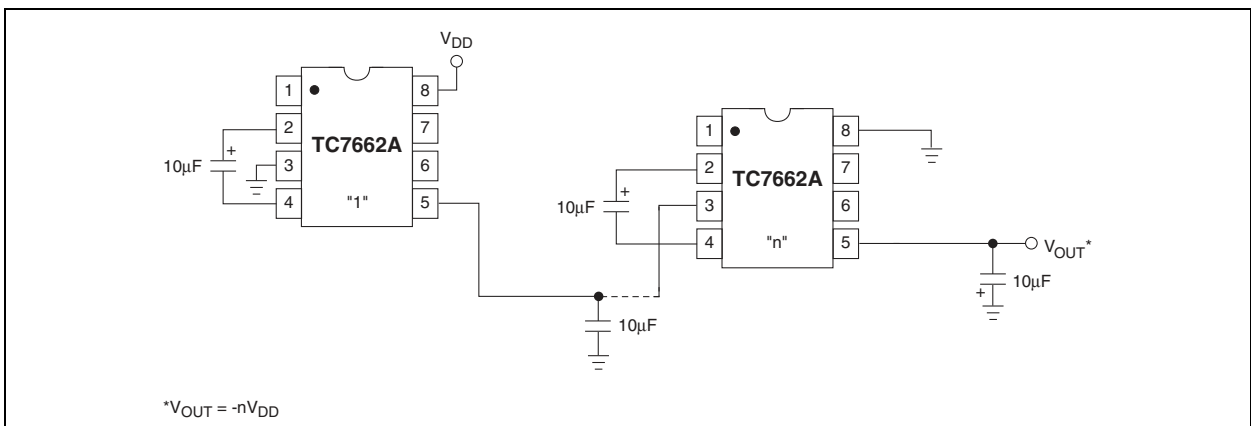

# TC7662A

## 4.5 Changing the TC7662A Oscillator Frequency

It is possible to increase the conversion efficiency of the TC7662A at low load levels by lowering the oscillator frequency. This reduces the switching losses, and is shown in Figure 4-5. However, lowering the oscillator frequency will cause an undesirable increase in the impedance of the pump ( $C_P$ ) and reservoir ( $C_R$ ) capacitors; this is overcome by increasing the values of  $C_P$  and  $C_R$  by the same factor that the frequency has been reduced. For example, the addition of a 100pF capacitor between pin 7 (OSC) and  $V_{DD}$  will lower the oscillator frequency to 2kHz from its nominal frequency of 12kHz (multiple of 6), and thereby necessitate a corresponding increase in the value of  $C_P$  and  $C_R$  (from 10 $\mu$ F to 68 $\mu$ F).

**FIGURE 4-5: LOWERING OSCILLATOR FREQUENCY**

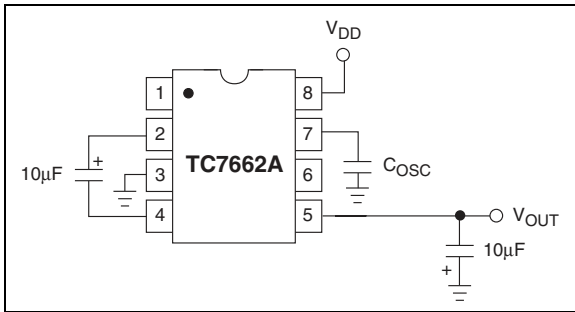

## 4.6 Positive Voltage Doubling

The TC7662A may be employed to achieve positive voltage doubling using the circuit shown in Figure 4-6. In this application, the pump inverter switches of the TC7662A are used to charge  $C_P$  to a voltage level of  $V_{DD} - V_F$  (where  $V_{DD}$  is the supply voltage and  $V_F$  is the forward voltage on  $C_P$  plus the supply voltage ( $V_{DD}$ ) applied through diode  $D_2$  to capacitor  $C_R$ ). The voltage thus created on  $C_R$  becomes  $(2 V_{DD}) - (2 V_F)$ , or twice the supply voltage minus the combined forward voltage drops of diodes  $D_1$  and  $D_2$ .

The source impedance of the output ( $V_{OUT}$ ) will depend on the output current, but for  $V_{DD} = 5V$  and an output current of 10 mA, it will be approximately 60 $\Omega$ .

**FIGURE 4-6: POSITIVE VOLTAGE MULTIPLIER**

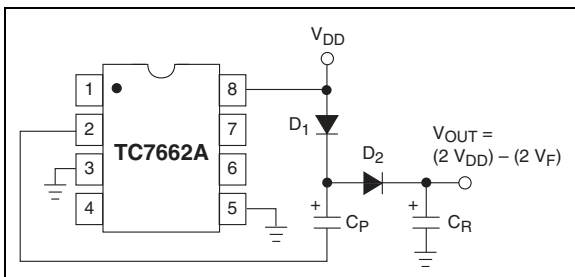

## 4.7 Combined Negative Voltage Conversion and Positive Supply Multiplication

Figure 4-7 combines the functions shown in Figure 4-1 and Figure 4-6 to provide negative voltage conversion and positive voltage doubling simultaneously. This approach would be, for example, suitable for generating +9V and -5V from an existing +5V supply. In this instance, capacitors  $C_1$  and  $C_3$  perform the pump and reservoir functions, respectively, for the generation of the negative voltage, while capacitors  $C_2$  and  $C_4$  are pump and reservoir, respectively, for the doubled positive voltage. There is a penalty in this configuration which combines both functions, however, in that the source impedances of the generated supplies will be somewhat higher due to the finite impedance of the common charge pump driver at pin 2 of the device.

**FIGURE 4-7: COMBINED NEGATIVE CONVERTER AND POSITIVE DOUBLER**

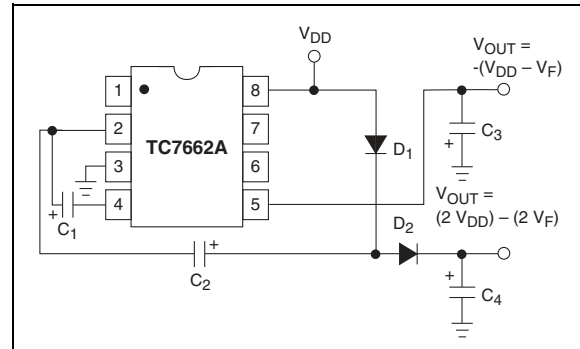

## 4.8 Voltage Splitting

The same bidirectional characteristics can be used to split a higher supply in half, as shown in Figure 4-8. The combined load will be evenly shared between the two sides. Because the switches share the load in parallel, the output impedance is much lower than in the standard circuits, and higher currents can be drawn from the device. By using this circuit, and then the circuit of Figure 4-4, +15V can be converted (via +7.5V and -7.5V) to a nominal -15V, though with rather high series resistance (~250 $\Omega$ ).

**FIGURE 4-8: SPLITTING A SUPPLY IN HALF**

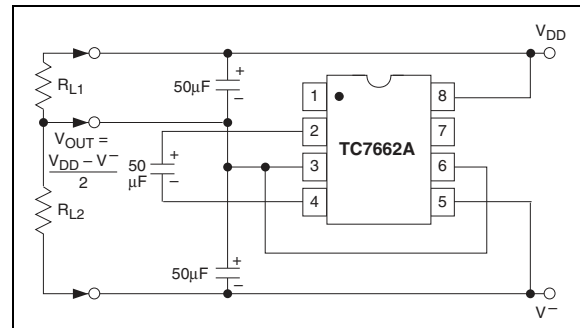



## 5.0 TYPICAL CHARACTERISTICS

**Note:** The graphs and tables provided following this note are a statistical summary based on a limited number of samples and are provided for informational purposes only. The performance characteristics listed herein are not tested or guaranteed. In some graphs or tables, the data presented may be outside the specified operating range (e.g., outside specified power supply range) and therefore outside the warranted range.

Circuit of Figure 3-1,  $C_P = C_R = 10\mu\text{F}$ ,  $C_{ESRCP} \approx C_{ESRCR} \approx 1\Omega$ ,  $T_A = 25^\circ\text{C}$  unless otherwise noted.

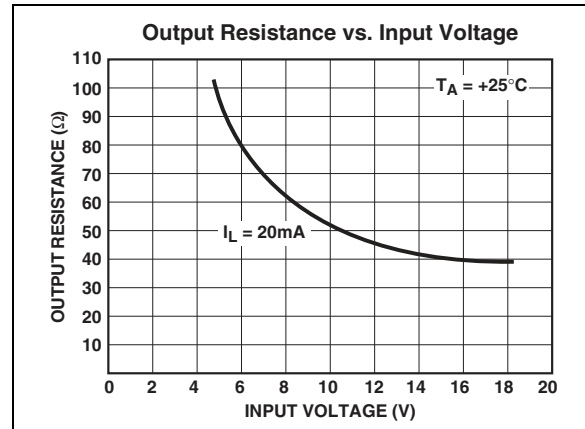
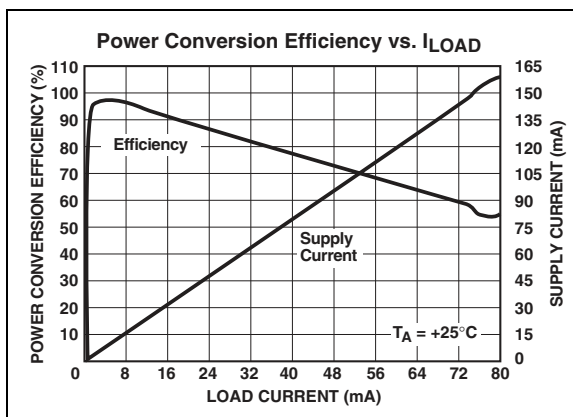
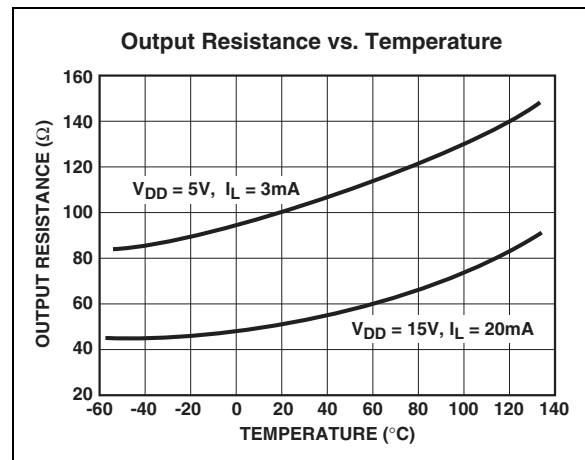
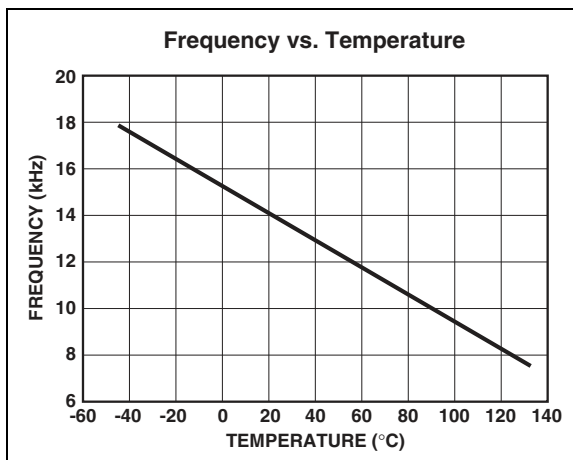
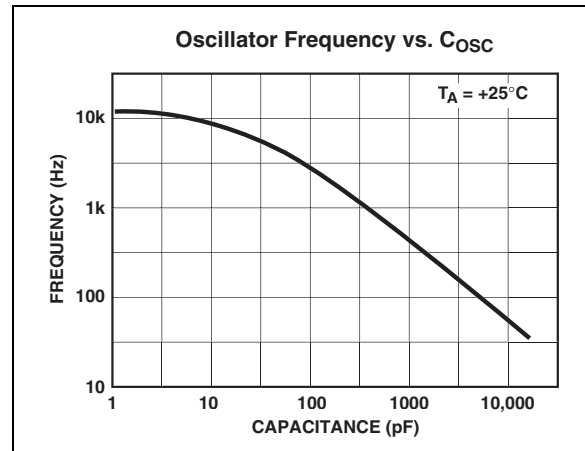
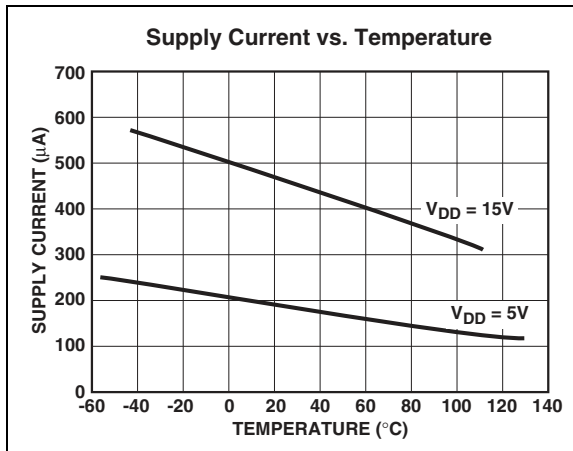

# TC7662A

## 6.0 PACKAGING INFORMATION

### 6.1 Package Marking Information

Package marking data not available at this time.

### 6.2 Package Dimensions

**Note:** For the most current package drawings, please see the Microchip Packaging Specification located at <http://www.microchip.com/packaging>

#### 8-Pin Plastic DIP

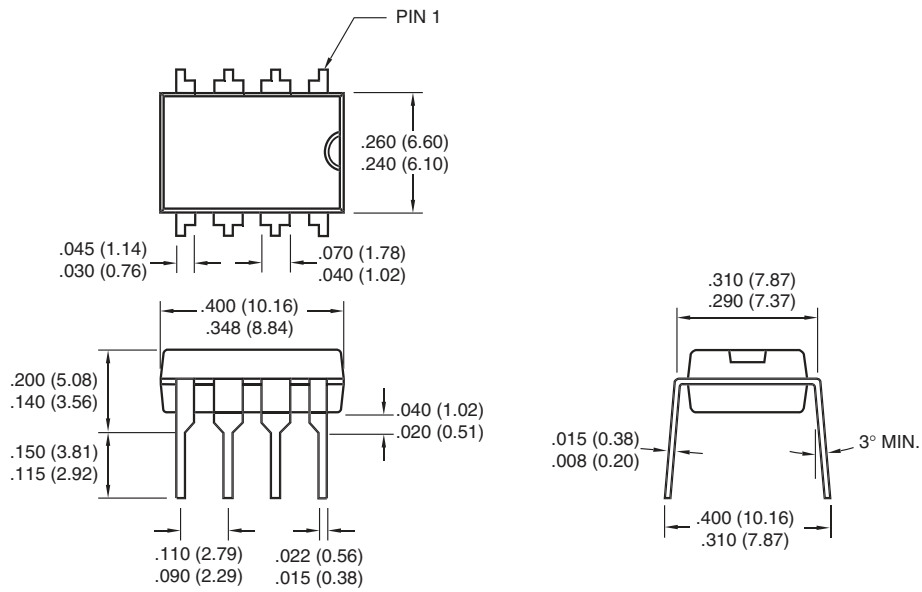

Dimensions: inches (mm)

**Note:** For the most current package drawings, please see the Microchip Packaging Specification located at <http://www.microchip.com/packaging>

## 8-Pin CDIP (Narrow)

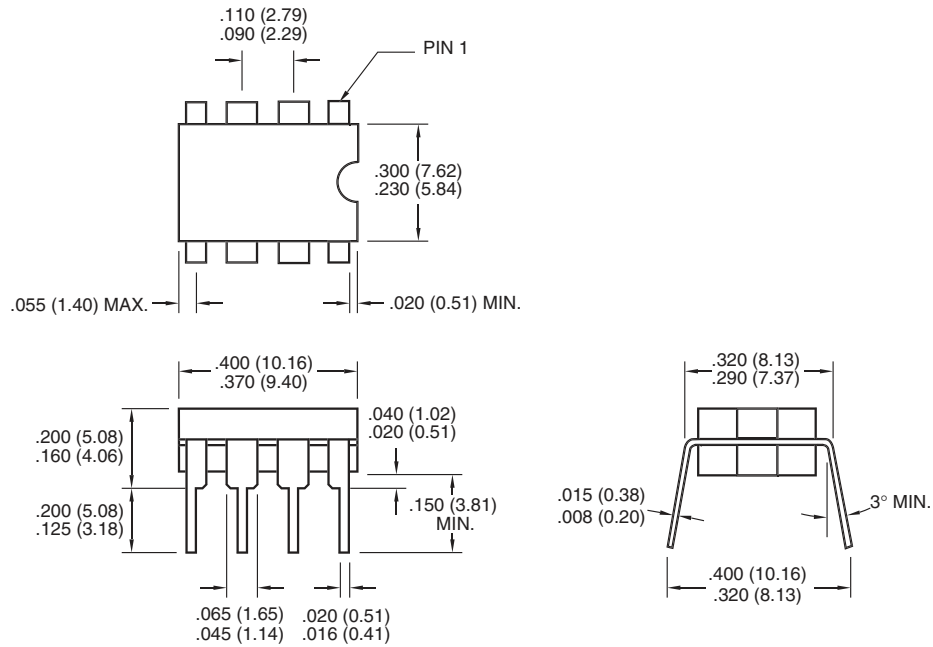

Dimensions: inches (mm)

# TC7662A

---

---

## 7.0 REVISION HISTORY

### Revision B (December 2012)

Added a note to each package outline drawing.

## **Sales and Support**

### **Data Sheets**

Products supported by a preliminary Data Sheet may have an errata sheet describing minor operational differences and recommended workarounds. To determine if an errata sheet exists for a particular device, please contact one of the following:

1. Your local Microchip sales office
2. The Microchip Worldwide Site ([www.microchip.com](http://www.microchip.com))

Please specify which device, revision of silicon and Data Sheet (include Literature #) you are using.

### **New Customer Notification System**

Register on our web site ([www.microchip.com/cn](http://www.microchip.com/cn)) to receive the most current information on our products.

# TC7662A

---

---

NOTES:

---

**Note the following details of the code protection feature on Microchip devices:**

- Microchip products meet the specification contained in their particular Microchip Data Sheet.
- Microchip believes that its family of products is one of the most secure families of its kind on the market today, when used in the intended manner and under normal conditions.
- There are dishonest and possibly illegal methods used to breach the code protection feature. All of these methods, to our knowledge, require using the Microchip products in a manner outside the operating specifications contained in Microchip's Data Sheets. Most likely, the person doing so is engaged in theft of intellectual property.
- Microchip is willing to work with the customer who is concerned about the integrity of their code.
- Neither Microchip nor any other semiconductor manufacturer can guarantee the security of their code. Code protection does not mean that we are guaranteeing the product as “unbreakable.”

Code protection is constantly evolving. We at Microchip are committed to continuously improving the code protection features of our products. Attempts to break Microchip's code protection feature may be a violation of the Digital Millennium Copyright Act. If such acts allow unauthorized access to your software or other copyrighted work, you may have a right to sue for relief under that Act.

---

Information contained in this publication regarding device applications and the like is provided only for your convenience and may be superseded by updates. It is your responsibility to ensure that your application meets with your specifications. MICROCHIP MAKES NO REPRESENTATIONS OR WARRANTIES OF ANY KIND WHETHER EXPRESS OR IMPLIED, WRITTEN OR ORAL, STATUTORY OR OTHERWISE, RELATED TO THE INFORMATION, INCLUDING BUT NOT LIMITED TO ITS CONDITION, QUALITY, PERFORMANCE, MERCHANTABILITY OR FITNESS FOR PURPOSE. Microchip disclaims all liability arising from this information and its use. Use of Microchip devices in life support and/or safety applications is entirely at the buyer's risk, and the buyer agrees to defend, indemnify and hold harmless Microchip from any and all damages, claims, suits, or expenses resulting from such use. No licenses are conveyed, implicitly or otherwise, under any Microchip intellectual property rights.

**Trademarks**

The Microchip name and logo, the Microchip logo, dsPIC, FlashFlex, KEELOQ, KEELOQ logo, MPLAB, PIC, PICmicro, PICSTART, PIC<sup>32</sup> logo, rPIC, SST, SST Logo, SuperFlash and UNI/O are registered trademarks of Microchip Technology Incorporated in the U.S.A. and other countries.

FilterLab, Hampshire, HI-TECH C, Linear Active Thermistor, MTP, SEEVAL and The Embedded Control Solutions Company are registered trademarks of Microchip Technology Incorporated in the U.S.A.

Silicon Storage Technology is a registered trademark of Microchip Technology Inc. in other countries.

Analog-for-the-Digital Age, Application Maestro, BodyCom, chipKIT, chipKIT logo, CodeGuard, dsPICDEM, dsPICDEM.net, dsPICworks, dsSPEAK, ECAN, ECONOMONITOR, FanSense, HI-TIDE, In-Circuit Serial Programming, ICSP, Mindi, MiWi, MPASM, MPF, MPLAB Certified logo, MPLIB, MPLINK, mTouch, Omniclient Code Generation, PICC, PICC-18, PICDEM, PICDEM.net, PICkit, PICtail, REAL ICE, rLAB, Select Mode, SQI, Serial Quad I/O, Total Endurance, TSHARC, UniWinDriver, WiperLock, ZENA and Z-Scale are trademarks of Microchip Technology Incorporated in the U.S.A. and other countries.

SQTP is a service mark of Microchip Technology Incorporated in the U.S.A.

GestIC and ULPP are registered trademarks of Microchip Technology Germany II GmbH & Co. & KG, a subsidiary of Microchip Technology Inc., in other countries.

All other trademarks mentioned herein are property of their respective companies.

© 2001-2012, Microchip Technology Incorporated, Printed in the U.S.A., All Rights Reserved.

 Printed on recycled paper.

ISBN: 9781620768426

**QUALITY MANAGEMENT SYSTEM**  
**CERTIFIED BY DNV**  
**== ISO/TS 16949 ==**

*Microchip received ISO/TS-16949:2009 certification for its worldwide headquarters, design and wafer fabrication facilities in Chandler and Tempe, Arizona; Gresham, Oregon and design centers in California and India. The Company's quality system processes and procedures are for its PIC<sup>®</sup> MCUs and dsPIC<sup>®</sup> DSCs, KEELOQ<sup>®</sup> code hopping devices, Serial EEPROMs, microperipherals, nonvolatile memory and analog products. In addition, Microchip's quality system for the design and manufacture of development systems is ISO 9001:2000 certified.*



# MICROCHIP

## Worldwide Sales and Service

### AMERICAS

**Corporate Office**  
2355 West Chandler Blvd.  
Chandler, AZ 85224-6199  
Tel: 480-792-7200  
Fax: 480-792-7277  
Technical Support:  
<http://www.microchip.com/support>  
Web Address:  
[www.microchip.com](http://www.microchip.com)

**Atlanta**  
Duluth, GA  
Tel: 678-957-9614  
Fax: 678-957-1455

**Boston**  
Westborough, MA  
Tel: 774-760-0087  
Fax: 774-760-0088

**Chicago**  
Itasca, IL  
Tel: 630-285-0071  
Fax: 630-285-0075

**Cleveland**  
Independence, OH  
Tel: 216-447-0464  
Fax: 216-447-0643

**Dallas**  
Addison, TX  
Tel: 972-818-7423  
Fax: 972-818-2924

**Detroit**  
Farmington Hills, MI  
Tel: 248-538-2250  
Fax: 248-538-2260

**Indianapolis**  
Noblesville, IN  
Tel: 317-773-8323  
Fax: 317-773-5453

**Los Angeles**  
Mission Viejo, CA  
Tel: 949-462-9523  
Fax: 949-462-9608

**Santa Clara**  
Santa Clara, CA  
Tel: 408-961-6444  
Fax: 408-961-6445

**Toronto**  
Mississauga, Ontario,  
Canada  
Tel: 905-673-0699  
Fax: 905-673-6509

### ASIA/PACIFIC

**Asia Pacific Office**  
Suites 3707-14, 37th Floor  
Tower 6, The Gateway  
Harbour City, Kowloon  
Hong Kong  
Tel: 852-2401-1200  
Fax: 852-2401-3431

**Australia - Sydney**  
Tel: 61-2-9868-6733  
Fax: 61-2-9868-6755

**China - Beijing**  
Tel: 86-10-8569-7000  
Fax: 86-10-8528-2104

**China - Chengdu**  
Tel: 86-28-8665-5511  
Fax: 86-28-8665-7889

**China - Chongqing**  
Tel: 86-23-8980-9588  
Fax: 86-23-8980-9500

**China - Hangzhou**  
Tel: 86-571-2819-3187  
Fax: 86-571-2819-3189

**China - Hong Kong SAR**  
Tel: 852-2943-5100  
Fax: 852-2401-3431

**China - Nanjing**  
Tel: 86-25-8473-2460  
Fax: 86-25-8473-2470

**China - Qingdao**  
Tel: 86-532-8502-7355  
Fax: 86-532-8502-7205

**China - Shanghai**  
Tel: 86-21-5407-5533  
Fax: 86-21-5407-5066

**China - Shenyang**  
Tel: 86-24-2334-2829  
Fax: 86-24-2334-2393

**China - Shenzhen**  
Tel: 86-755-8864-2200  
Fax: 86-755-8203-1760

**China - Wuhan**  
Tel: 86-27-5980-5300  
Fax: 86-27-5980-5118

**China - Xian**  
Tel: 86-29-8833-7252  
Fax: 86-29-8833-7256

**China - Xiamen**  
Tel: 86-592-2388138  
Fax: 86-592-2388130

**China - Zhuhai**  
Tel: 86-756-3210040  
Fax: 86-756-3210049

### ASIA/PACIFIC

**India - Bangalore**  
Tel: 91-80-3090-4444  
Fax: 91-80-3090-4123

**India - New Delhi**  
Tel: 91-11-4160-8631  
Fax: 91-11-4160-8632

**India - Pune**  
Tel: 91-20-2566-1512  
Fax: 91-20-2566-1513

**Japan - Osaka**  
Tel: 81-6-6152-7160  
Fax: 81-6-6152-9310

**Japan - Tokyo**  
Tel: 81-3-6880-3770  
Fax: 81-3-6880-3771

**Korea - Daegu**  
Tel: 82-53-744-4301  
Fax: 82-53-744-4302

**Korea - Seoul**  
Tel: 82-2-554-7200  
Fax: 82-2-558-5932 or  
82-2-558-5934

**Malaysia - Kuala Lumpur**  
Tel: 60-3-6201-9857  
Fax: 60-3-6201-9859

**Malaysia - Penang**  
Tel: 60-4-227-8870  
Fax: 60-4-227-4068

**Philippines - Manila**  
Tel: 63-2-634-9065  
Fax: 63-2-634-9069

**Singapore**  
Tel: 65-6334-8870  
Fax: 65-6334-8850

**Taiwan - Hsin Chu**  
Tel: 886-3-5778-366  
Fax: 886-3-5770-955

**Taiwan - Kaohsiung**  
Tel: 886-7-213-7828  
Fax: 886-7-330-9305

**Taiwan - Taipei**  
Tel: 886-2-2508-8600  
Fax: 886-2-2508-0102

**Thailand - Bangkok**  
Tel: 66-2-694-1351  
Fax: 66-2-694-1350

### EUROPE

**Austria - Wels**  
Tel: 43-7242-2244-39  
Fax: 43-7242-2244-393

**Denmark - Copenhagen**  
Tel: 45-4450-2828  
Fax: 45-4485-2829

**France - Paris**  
Tel: 33-1-69-53-63-20  
Fax: 33-1-69-30-90-79

**Germany - Munich**  
Tel: 49-89-627-144-0  
Fax: 49-89-627-144-44

**Italy - Milan**  
Tel: 39-0331-742611  
Fax: 39-0331-466781

**Netherlands - Drunen**  
Tel: 31-416-690399  
Fax: 31-416-690340

**Spain - Madrid**  
Tel: 34-91-708-08-90  
Fax: 34-91-708-08-91

**UK - Wokingham**  
Tel: 44-118-921-5869  
Fax: 44-118-921-5820

11/29/12