

QPO-2 Low Voltage Output Ripple Attenuator

Description

The QPO-2 output ripple attenuator SiP uses active filtering to reduce supply output ripple and noise (PARD) by over 30 dB from 1 kHz to 500 kHz. The QPO-2 is biased through the VAUX input and filters an input voltage range of 0.3 Vdc to 5.5 Vdc while supporting load currents as high as 20 A. The VAUX input range is 7 V to 12 V with a minimum required difference between VAUX and QPO OUT of 7 V. Output regulation is maintained by using either the remote sense or the trim adjustment of the power supply. The product can be used in an open loop configuration when ripple and noise reduction are the main objective and load regulation is not as critical. The QPO-2 architecture improves transient response and ensures quiet point-of-load regulation when used with most switching power supplies. The performance waveform in figure 2 is an example of the ripple reduction and transient load improvement the QPO-2 can provide using a 3.3V brick style converter.

Applications

- Distributed Point of Load Power Systems
- Sensors Requiring Low Noise Power
- Medical Instrumentation

Features of the QPO-2

- >30 dB PARD attenuation, 1 kHz to 500 kHz
- >20 dB PARD attenuation, 50 Hz to 500 Hz (1)
- 20 A rating over a 0.3-5.5 Vdc operating range
- Supports precise point-of load regulation
- 90-95% efficiency with load vs. headroom trim
- User selectable performance optimization of the attenuation, power dissipation & transient load response
- Peak detector function optimizes headroom for ripple amplitude variation automatically
- 25 x 25 x 4.5 mm SiP (System-in-a-Package)
- Low profile LGA package
- Closed loop control improves transient response of most DC-DC converters and power supplies
- Reduces required number of output capacitors to support dynamic loads.
- Patents Pending

Note 1: For off-line supplies 20 dB attenuation can be achieved down to 50 Hz with additional capacitance added from the VREF pin to REFGND.

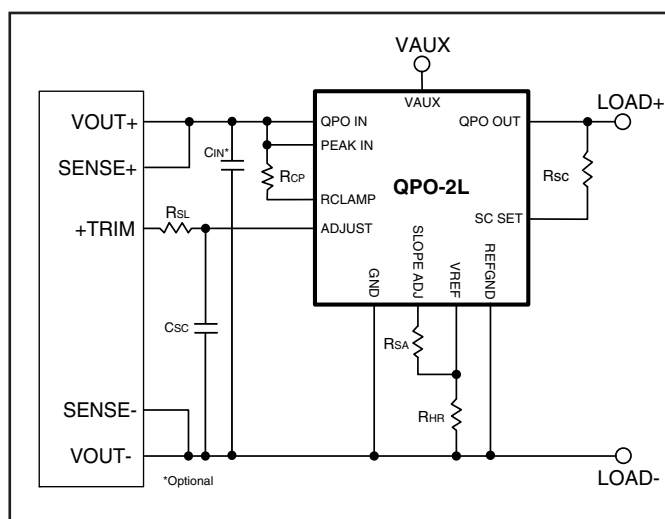

Figure 1 – ADJUST/Trim supports applications that don't require remote sense.

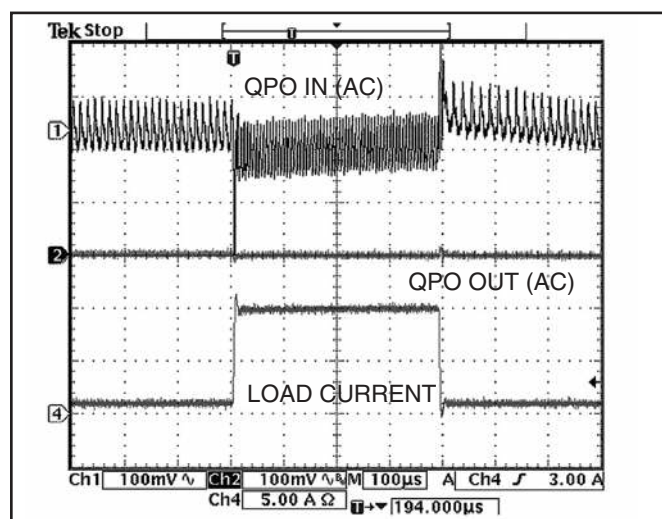

Figure 2 – Typical performance with a 3.3 Volt converter, showing 1 to 10 A load step.

End of Life

Absolute Maximum Ratings – Exceeding these parameters may result in permanent damage to the product.

Pins	Parameter	Notes	Min	Max	Units
VAUX to Gnd	Input voltage	Continuous	-0.5	13.2	Vdc
All others to Gnd REFGND	Input voltage	Continuous	-.05	6	Vdc
VAUX to Gnd	Input bias current			50	mAdc
QPOin to QPOout	Input to output current	10 seconds @ 25°C		25	Adc
Package	Power dissipation	Pd= ILoad x Vhr		4	W
Package	Operating temperature	PCB to QPO Interface	-40	100	°C
Package	Thermal resistance	Free Air	50		°C/W
Package	Thermal resistance	PCB Layout Fig. 12	12		°C/W
Package	Storage temperature		-40	125	°C
Package	Re-flow temperature	20 second exposure @ (4)		212	°C

Electrical Characteristics – Parameter limits apply over the operating temp. range unless otherwise noted.

Symbol	Parameter	Notes	Min	Max	Units
ILoad	Operating load current range	No Internal Current Limit (2)	0.01 (3)	20	Adc
VQPOOUT	Output voltage range	Continuous	0.3	5.5	Vdc
VHR	Headroom voltage range	See Applications Detail For Setting	75	425	mVdc
IAUX	VAUX input current		10	20	mA
Vtout	Transient response-step load change of 10A@<1A/usec	Vhr=375mV Cin=200uF Iload=1A @ t=0 See Figure 2 example	50		mVdc
Vnout	Output noise	Input PARD=100mVpp 50-500kHz Cvref=25uF		10	mVpp
				5	mVrms
Iscout	SC output current accuracy	See applications detail for setting	-2	+2	%
Iscout	SC output source current	Input current from QPOIN to Gnd		10	mA

Note 2: User must protect the load path and limit the steady state load current to be less than the absolute maximum of 20 Amps.

Note 3: User must provide a minimum load current of greater than 10mA at the output of the QPO-2.

Note 4: RoHS compliant product maximum peak temperature is 245°C for 20 seconds.

Pad Descriptions

Pad Number	Name	Description
1, 19, 20	GND	Input ground
2	SLOPE ADJ	Rsa resistor connection allows setting of slope of headroom voltage vs. load (mV/A)
3	VREF	Input to the active filter, setting the output voltage at the QPOOUT pins
4	REFGND	Ground reference for the VREF pin (critical low noise connection)
5	SC SET	Rsc resistor connection allows setting of the SC/trim current applied to the converter trim input.
6, 7, 8, 17	QPOOUT	Output pins
9	VAUX	Input bias voltage
10	RCLAMP	External resistor to program VREF quick-charge level at start-up
11, 12, 13, 14, 18	QPOIN	Input pins (critical thermal path to remove heat from the package, see PCB suggested layout Fig.13)
15	PEAK IN	Ripple Peak Detector Input
16	ADJUST	A current source that mirrors the current through Rsc and drives a converter's SC/TRIM pin.

LGA Pattern

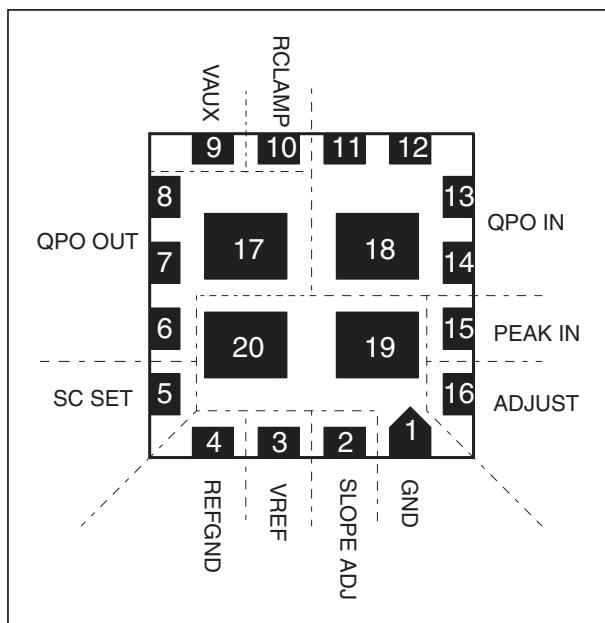

Product Highlights

Picor's QPO-2, System-in-a-Package (SiP) output ripple attenuator, is easy to apply and provides the user with features that can be tailored to optimize the product's performance to meet their system needs. It uses active filtering to achieve greater than 30 dB of attenuation of Periodic And Random Deviation (PAR) over the frequency range of 1 kHz to 500 kHz. For converters running off-line with greater low frequency output ripple, the attenuation can be extended to be greater than 20 dB down at 50 Hz by connecting a 25 uF capacitor between the VREF and REFGRD pins.

The QPO-2 operates over an output voltage range of 0.3 to 5.5 Vdc and requires an external input bias voltage of 7 volts above the QPO output for proper operation. It is compatible with most switching power supplies and converters and regulates the output load by using either a converter's remote sensing feature or the SC/trim function of the QPO-2 with the converter. The SC/Trim feature will correct the converter's output voltage to compensate for the headroom voltage drop of the filter if remote sensing is not available or not preferred. The QPO-2 SC function works with converters that feature a positive reference trim adjustment by sourcing correction current into the trim reference pins commonly found on many power supplies. The QPO-2 can also be used when remote sense or SC/trim is not possible. In this mode of operation the QPO-2 will still provide greater than 30 dB of ripple and noise attenuation but DC errors will not be corrected for once the converter and headroom voltages are set, resulting in reduced load and transient performance.

The QPO-2's closed loop architecture greatly improves load transient response of the converter while ensuring steady-state precise point of load voltage regulation. The headroom setting of the filter dramatically reduces the capacitance needed at the converter output to provide the equivalent transient performance and ripple reduction. Figure 2 demonstrates how the product can be an ideal solution for noise sensitive applications providing ripple and noise reduction and improved output regulation with high current transient load demands.

Functional Description

The QPO-2 is an active power filter that provides conducted differential attenuation of power supply output PAR. It is design to be inserted between the output of the supply and the load, providing closed loop regulation through remote sensing or by means of the SC/Trim feature of supplies having a positive referenced based trim capability and is set by RSC. The core of the design is a high bandwidth closed loop function that forces the QPOOUT pins to be equal to the VREF pin. The VREF pin is a filtered ratio metric representation of the input voltage that is determined by the RHR value selection. The voltage difference between the input to the QPO-2 and VREF pin is defined as the headroom voltage VHR. The filter time constant of the VREF pin determines the low frequency attenuation response of the QPO-2. The high frequency attenuation response is determined by the roll-off characteristics of the active loop. To speed up the charging of the Vref pin the RCP resistor can be used to clamp the pin just below the steady state regulation point avoiding excessive delay and headroom during start-up.

The QPO-2 has a current sensing function that creates a voltage at the Slope Adjust pin that is proportional with the load current. This feature can be used to improve the efficiency of the filter when supply ripple amplitude reduces with increasing load as with Vicor products. By selecting the appropriate R_{SA} resistor value the slope of the headroom reduction versus load can be set. The effect of this function is to reduce the headroom voltage by the amount determined by the R_{SA} value resulting in reduced power dissipation and increased efficiency as compared to a fixed headroom setting.

There is also a Peak Detection function that adds the input peak of the ripple voltage to the headroom voltage. The QPO-2 will track the input ripple adjusting the headroom within the dynamic range of the filter as the peak of the ripple changes. The peak of the ripple will automatically be summed with the DC setting of the headroom voltage. This feature in combination with the slope adjust feature allows the user to optimize the initial headroom voltage and overall efficiency required for their specific application.

Remote Sense Application Circuit Schematic

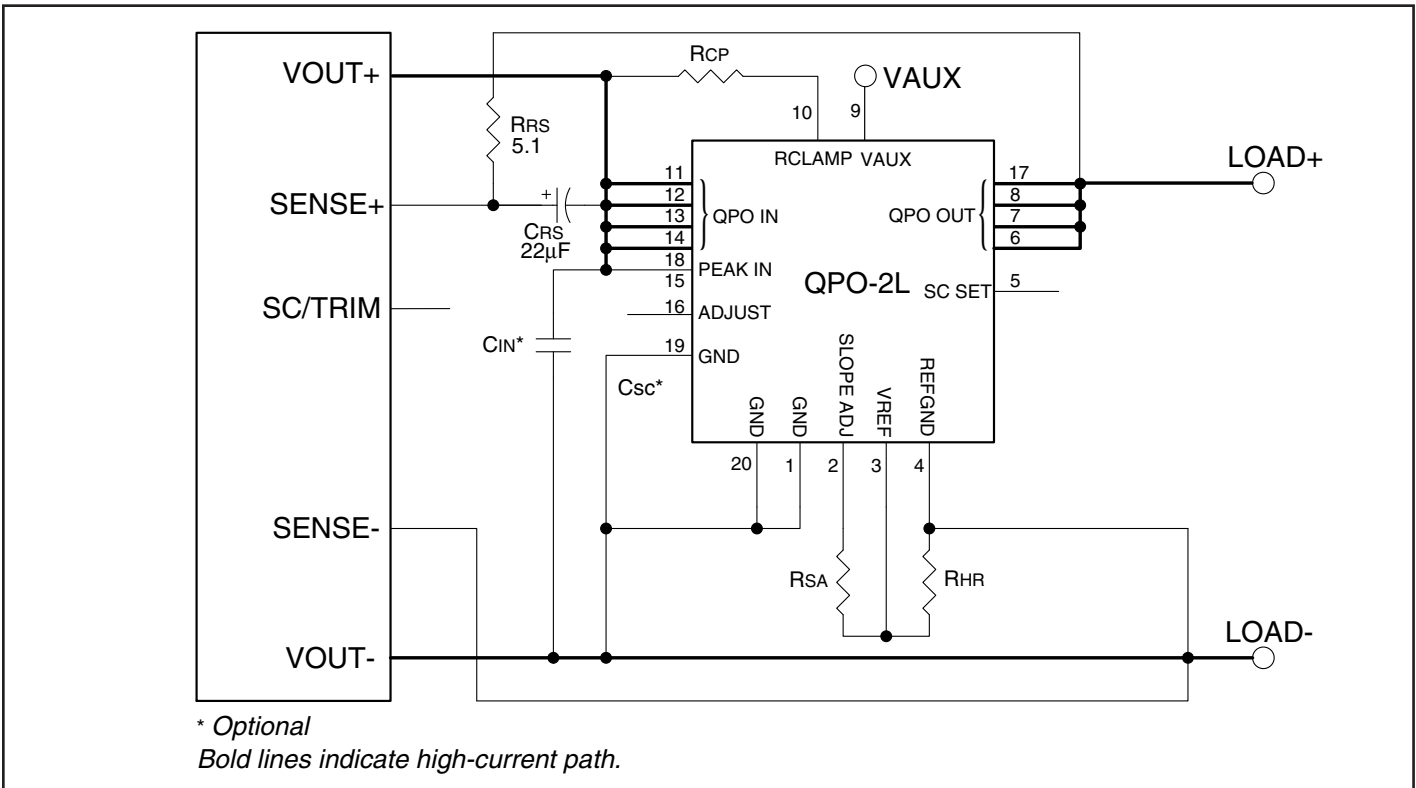

Figure 3 – Use this circuit for applications requiring remote sensing. Components marked * are optional, see text.

SC/Trim Application Circuit Schematic

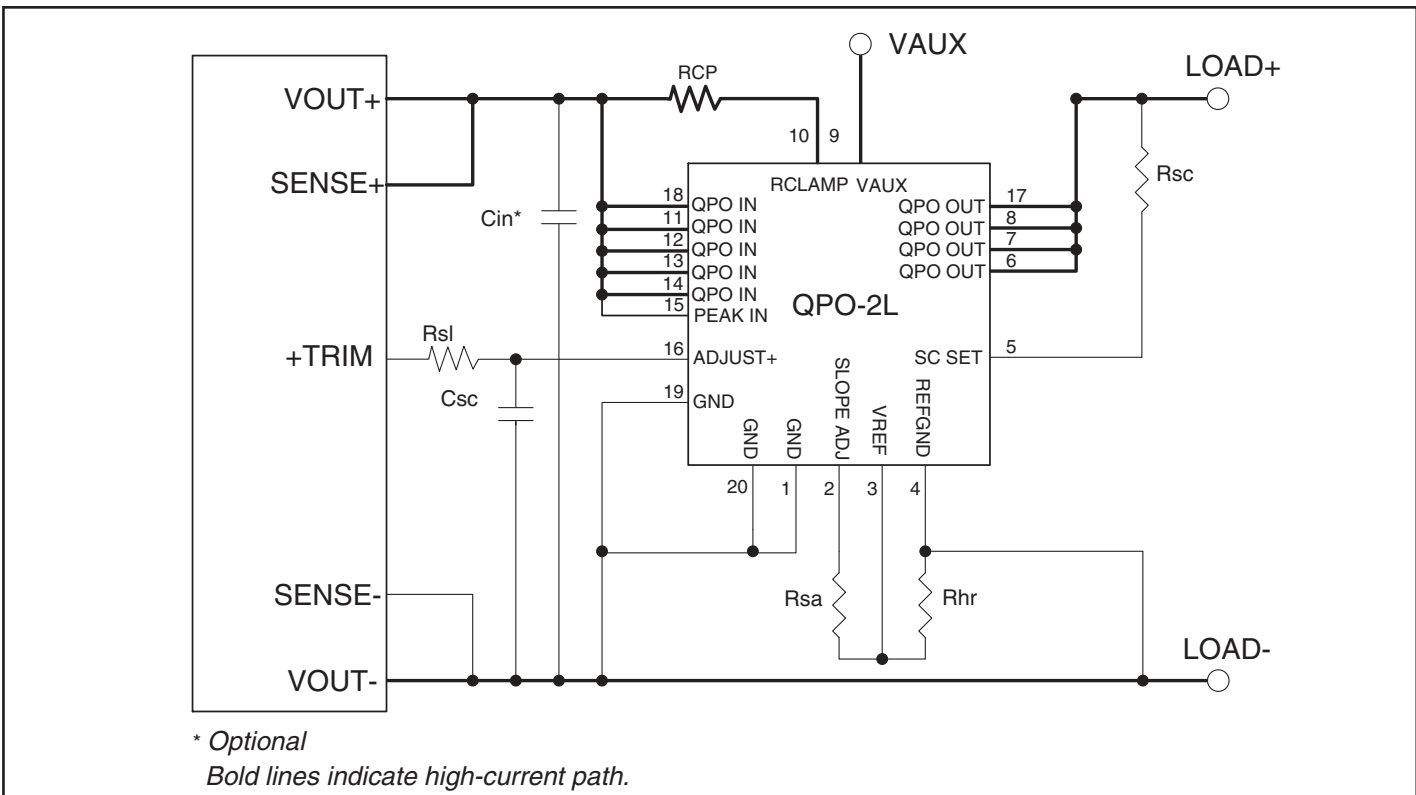

Figure 4 – Simplest application of QPO-2 when the SC/Trim pin is available, see text.

Application of the QPO-2

This product can be used over a 0.3 Vdc to 5.5 Vdc output voltage range using either the remote sense or the voltage trim feature of the selected converter. These circuit configurations are shown in Figures 3 and 4.

In either configuration, the source output voltage will increase to accommodate the headroom voltage of the QPO-2 filter in order to maintain the load voltage at the required level. In the case where remote sense or SC/Trim use is not possible the QPO-2 can still be used to provide PARD attenuation with the DC loss of the headroom voltage at the load. If the supply output can be trimmed up, the headroom voltage drop of the QPO-2 can be compensated for at a given load. Further DC correction for load variation at the QPO-2 output will occur only within the supply's control loop. The QPO-2's output will be controlled to the voltage present at the VREF pin in this open loop filter configuration.

The user must decide on the control mode to be used and to select the appropriate circuit configuration for that mode. They must take into consideration the effects of the headroom setting and power dissipation versus PARD attenuation. The majority of the power dissipation of the QPO-2 is the product of the headroom voltage times the load current and must always be less than 4 watts. The dynamic headroom range of the QPO-2 is 75 mv to 425 mv as long as the maximum power is not exceeded. It is important that the user understands the range of expected ripple and transient performance of their power source to properly bias and utilize the QPO features. The objective is to maximize attenuation and minimize dissipation while staying within the QPO-2 dynamic operating range. Knowing the worst case maximum steady state ripple, output impedance and transient response time of the power source will determine the minimum required headroom of the QPO-2, which is set by the value of R_{HR} . See figure 5 below for the safe operating power curve.

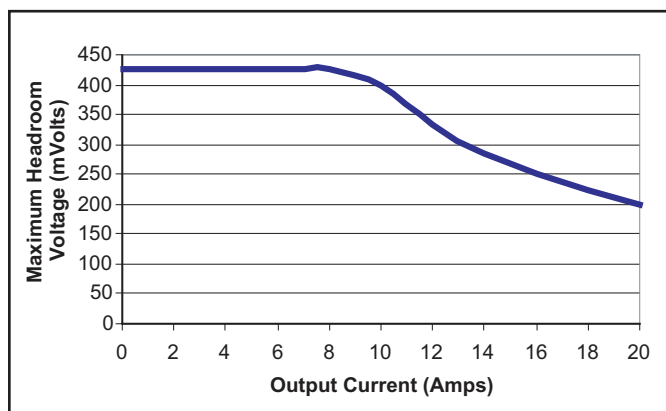

Figure 5 – Safe operating power curve.

If the peak detector option is enabled the headroom will automatically increase by the peak of the ripple amplitude from the setting determined by R_{HR} . This makes the initial headroom setting less critical because the headroom and dynamic range will track the peak of the ripple, maintaining the required QPO-2 biasing to actively attenuate. Caution must be taken such that the added peak detection headroom does not cause power dissipation in excess of 4 watts. The time constant of this feature is roughly 30 ms in response to ripple amplitude changes. This feature can be enabled by connecting the PEAKIN pin to the QPOIN pins and disabled by putting a resistor between QPOIN and the PEAKIN pin as shown in Figure 6.

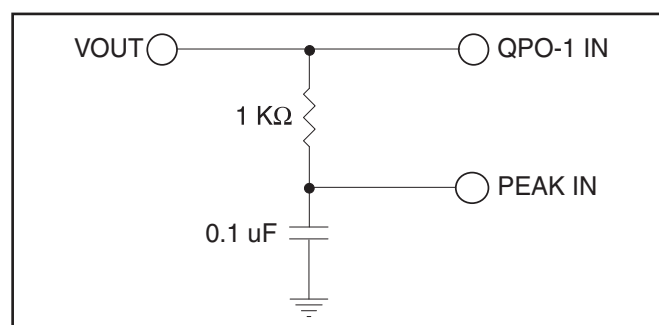

Figure 6 – Peak detect disable circuit.

Conversely the optional slope adjust feature will reduce the headroom proportional to load current depending on the R_{SA} value selected. This will reduce the maximum ripple range so this feature is most useful when the converter ripple amplitude decreases with increased load current. The feature can be enabled by selecting the proper R_{SA} value as described in the headroom slope adjust section of the datasheet and effectively disabled by using $R_{SA} = 100 \text{ Kohms}$.

Figure 7 shows the relationship of the headroom voltage versus attenuation of the QPO-2 for a 3.3 volt output with a 15 amp load. This relationship is relatively constant over the full output voltage rating of the product so this graph can be used for the 0.3 V to 5.5 V range when selecting the headroom voltage. The value of headroom resistor will be dependent on desired output and headroom voltages. The selection of the final headroom voltage should be based on the maximum expected ripple, desired attenuation, based on the curves in Figure 7, and the transient response time of the converter. Formulas for SC current setting resistor, R_{SC} and the R_{CP} clamp setting resistor, are provided in their respective sections. The headroom range indicated in Figure 7 shows that increasing the headroom voltage will increase the attenuation, up to a point of diminishing returns, over the range of 10 kHz to over 1 Mhz. With an external 25 μF

End of Life

capacitor connected between the VREF and REFUND pins the low frequency attenuation from 10 Hz to 10 kHz will reduce by roughly 10 dB. Review the following transient considerations below before selecting the operating headroom. The R_{HR} resistor value is determined by using the following formula.

$$R_{HR} = \frac{QPO_{OUT}}{V_{HR} + 15 \text{ mV}} * 2.5 \text{ k}\Omega$$

where; R_{HR} is headroom setting resistor value,

QPO_{OUT} is the expected voltage on the QPO's output,

V_{HR} is the target headroom voltage for the desired range of attenuation.

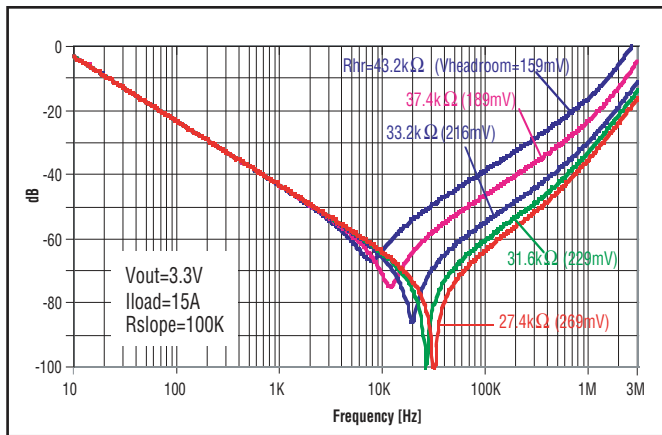

Figure 7 – Attenuation curves without slope adjust.

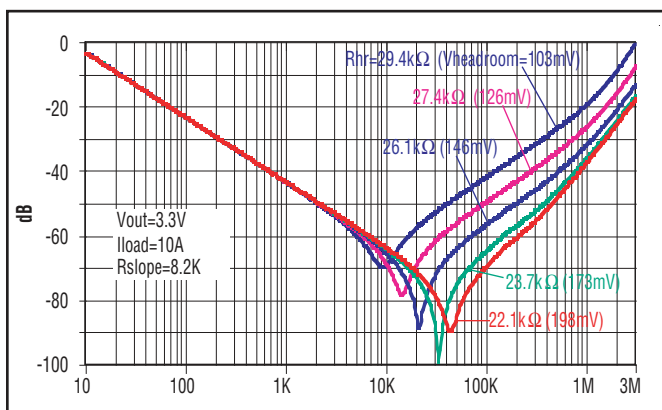

Figure 8 – Attenuation Curves Using Slope Adjust Feature

To ensure sufficient headroom during transient load changes, a greater headroom voltage than what would normally be set based on maximum ripple should be considered. To provide margin to cover the instantaneous drop in the converter output and the line drops, additional headroom will be needed. In the example shown in Figure 2 an additional 75 mV was included with the headroom voltage value selected from the graph in Figure 7 to cover the instantaneous drop in the supply output during the 10 Amp step as explained below.

In Figure 2, a maximum load of 10 Amps allowed for the R_{HR} value to be calculated to provide 375 mV of headroom to avoid exceeding 4 Watts. In this example, based on the attenuation graph in Figure 7, 300 mV of headroom is the point of diminishing returns so the maximum attenuation would be achieved at the fundamental ripple frequency. To stay within the dynamic range required by the active loop during a transient, a total of 375 mV was used in the formula to determine the R_{HR} resistor value. The peak detector will dynamically add 30 mV (derived from the 60 mV peak to peak input ripple) to the static headroom setting providing the total dynamic headroom of typically 405 mV with the detector enabled.

The input capacitance to the QPO-2 will provide the transient load current keeping the QPO_{OUT} at the VREF voltage until the converter loop responds to regulate the load. During this time the transient load current capability can be approximated by the formula below. The capacitance C_{IN} may be within the power supply that is used or supplemented by external capacitance. Consideration of the power supply's sensitivity to additional output capacitance and stability must be understood before additional capacitance is added for transient performance enhancement.

$$I = \frac{V_{HR}}{2Tr} * C_{IN}$$

where; C_{IN} = Input capacitance (assuming low ESR/ceramic type) at the QPO-2 input,

I = Step load current change,

Tr = Converter response time,

V_{HR} = headroom voltage.

The output voltage drop for a given supply during a transient load step will be reduced at the output of the QPO-2, effectively multiplying the C_{IN} capacitance by the ratio of V_{IN}/V_{OUT} which is typically greater than a factor of 10.

The line inductance from the output of the QPO-2 to the load should be minimized. This inductance will cause voltage spikes and ringing proportional to the inductance and the rate of change in the transient load current. This effect is outside the control of the QPO-2 and may require low ESR capacitance placed at the switching load when long lines exist between the QPO-2 output and reference ground and load. The rate of load change should be less than 1 Amp per microsecond to minimize excessive voltage ringing during the di/dt. The line inductance between the power supply output and QPO input should also follow low inductance layout practices.

The user must be aware of the converter's over-voltage set point and not create a headroom voltage that will cause a shutdown condition. For this reason it is recommended that the QPO-2 be used with power supplies running at the factory pre-set voltages or in a trimmed down configuration.

SC/Trim Adjustment

The RSC resistor is tied between QPOOUT and SC SET pin and controls the correction current used to trim the converter to compensate for the headroom voltage. The value for the SC SET resistor is calculated by the following equation:

$$R_{SC} = \frac{R_{IN} * V_{OUT}}{I_{RPT}}$$

where; R_{sc} is SC SET resistor value,

R_{IN} is the input resistance of the SC or TRIM input of the converter (4)

V_{OUT} is the desired QPO output voltage,

I_{RPT} is the pre-trimmed reference of the SC or TRIM.

This feature can be used in conjunction with an initially trimmed down supply.

Note 4: When applicable consider the equivalent impedance of the SC/Trim pin after a trimmed down adjustment has been made to the supply. Use the power supply manufacturer's trim down procedure by connecting a resistor from the SC/Trim pin to ground.

The active loop performance of the QPO-2 has been optimized to provide adequate phase margin over a worse case load impedance range. Loading the QPO-2 directly with low ESR ceramic capacitance however will significantly reduce the phase margin and is not recommended. The effects of the typical distributed inductance of the load path will mitigate the reduction in phase margin when low ESR ceramic capacitors are dispersed about the load path. Tantalum and Electrolytic capacitors are higher ESR components and are not a concern for phase margin.

When using the QPO as shown in Figure 4 the CSC capacitor creates a soft starting of the headroom correction current being sourced into the SC/Trim input of the converter, preventing the output from tripping the over voltage function while the QPO-2 output reaches regulation. The QPO-2 ramp up time is typically 5 to 10 milliseconds. The CSC value will be supply dependent but is typically around 1 to 10 μ F.

The R_{SL} resistor provides a means to isolate the SC/Trim pin of the converter from CSC as well as limit the correction current to a level below what will cause an OVP trip condition during start up. The compliance of the SC output current source is QPOIN plus 10 volts so the R_{SL} formula below can be used to limit the worst-case correction current below the maximum trim up specification of the converter being used. Note the correction current set by R_{sc} must always be lower than the I_{SCMAX} current after the start-up settling time interval for proper headroom correction.

$$R_{SL} = \frac{QPO_{IN} + 10 V}{I_{SCMAX}}$$

Headroom Slope Adjustment

This feature can be used to allow more headroom at lighter loads increasing the delta voltage available to improve transient load capability, while approximating constant power dissipation of the QPO-2 over the full load range. The slope of this curve is set by the slope adjust resistor R_{SA} . Figure 9 shows the relationship of headroom resistance versus power dissipation for a load current of 10 Amps. The same data is plotted in Figure 10 with the slope adjust feature reducing the headroom by 150 mV over the load range of 1 to 10 A, for a typical range of R_{HR} values with a 3.3 volt output. The headroom setting R_{HR} value was selected at the minimum load condition while enabling the slope function using an R_{SA} value of 8.2 k. This feature is useful in improving the QPO-2 efficiency

End of Life

when using switching power supplies that have decreasing ripple with increasing load current, like Vicor converters. Figure 8 shows the headroom voltage vs. load with different headroom resistors with $R_{SA} = 8.2 \text{ k}$.

The slope adjust feature can be effectively disabled, providing relatively constant headroom versus load, by using an R_{SA} of 100k. The user can optimize performance based on the expected variation in load current and the desired power dissipation range. The formula below should be used to calculate the R_{SA} value for the desired headroom versus current slope. If the peak detector is enabled, the peak of the ripple will be added back to the headroom at a given load condition.

$$R_{SA} = 0.05(V/A) * \frac{\Delta I_{OUT}}{\Delta V_{HR}} * 2.5 \text{ k}\Omega$$

where: I_{OUT} = Maximum load current change,

V_{HR} = Change in headroom desired over the load range,

R_{SA} = Slope adjust resistor value,

Example: For a 5 A maximum load and a 150mV reduction in headroom.

$$R_{SA} = 0.05(V/I) * \frac{5 \text{ A}}{0.15 \text{ V}} * 2.5 \text{ k}\Omega = 4.167 \text{ k}\Omega$$

Figures 9 and 10 demonstrate the attenuation versus power dissipation relationship with different headroom resistor values with corresponding increasing power dissipation at a fixed 10 A load. The low frequency attenuation is flat with changing headroom as indicated by the 50 Hz line. The active attenuation is dependent on the headroom voltage and correlates to the attenuation curves presented previously.

Figure 10 shows the increase in attenuation that can be gained by using the slope adjust feature setting higher headroom at lower loads while limiting the power dissipation with reduced headroom at higher loads staying within the 4 Watt limitation of the package. As stated previously this will also increase the transient capability with a load step providing more delta voltage across the filter at lower loads.

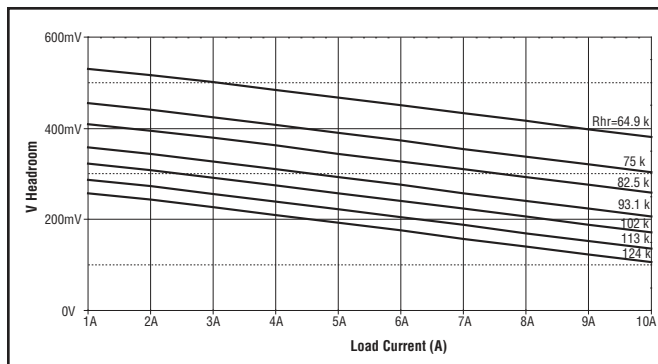

Figure 8 – Effect of slope adjust on headroom value with increasing current and $R_{SA} = 8.2 \text{ k}$.

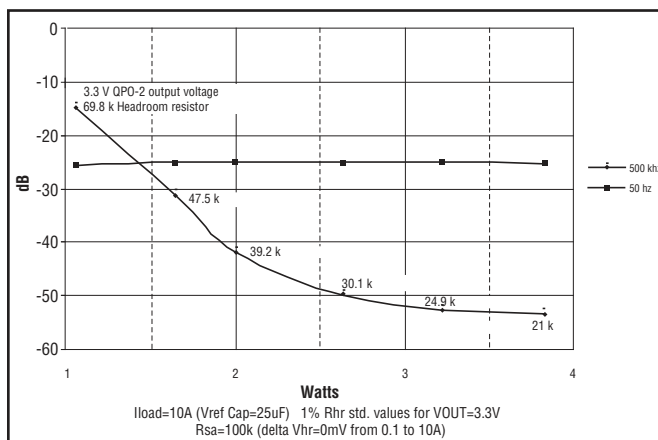

Figure 9 – Power dissipation vs. RHR (Headroom voltage)

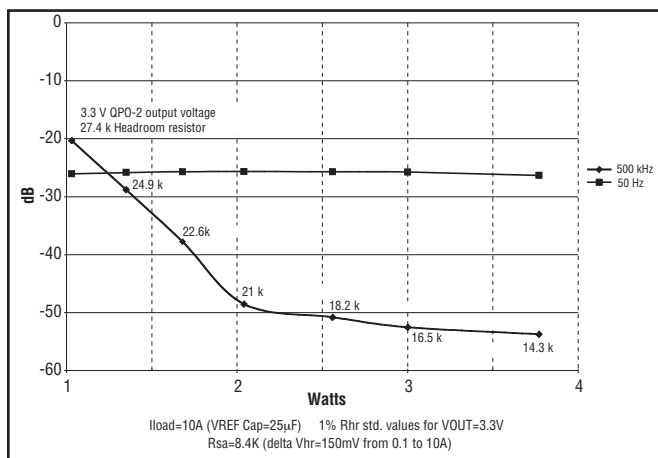

Figure 10 – Power dissipation vs. RHR (Headroom voltage) with 150 mV of slope adjust.

Headroom Start-up Clamp Feature

This feature allows for pre-charging the Vref capacitance to the level just below the steady state headroom voltage. It reduces the time for the QPO_{OUT} to reach the desired regulation voltage and converter output overshoot that results in the delay through the QPO filter during start-up. The following formula can be used to calculate the RCP resistor value to set the clamp at 90% of the final output value. To set the clamp voltage to different percentages of the output substitute the 0.90 with the desired factor.

$$R_{CP} = \frac{100k * (V_{QPO_{IN}} - 0.90 * V_{QPO_{OUT}})}{0.90 * V_{QPO_{OUT}}} \quad \square$$

The following is a summary of typical configurations that a user can select for the QPO-2.

- No slope adjust, no peak detect, fixed headroom, attenuation vs headroom graph in Figure 7 apply
- No slope adjust, peak detector enabled, headroom will increase by the peak of the ripple amplitude
- Slope adjust enabled, no peak detect, headroom will decrease with the increase in load current
- Slope adjust enabled, peak detector enabled, headroom will vary with ripple amplitude and load variations

The attributes of these features have been explained in this datasheet. The optimum use of them requires an understanding of the characteristics of the power supply to be filtered.

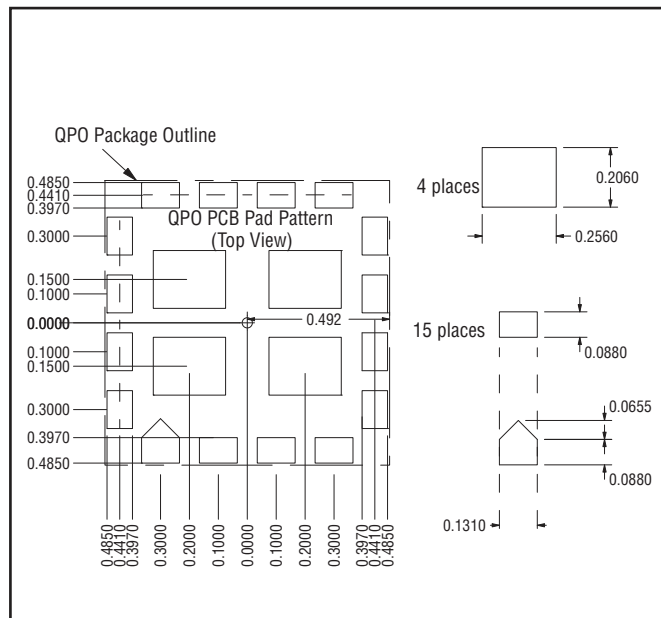

Figure 11 - Recommended PCB receptor patterns. (dimensions in inches)

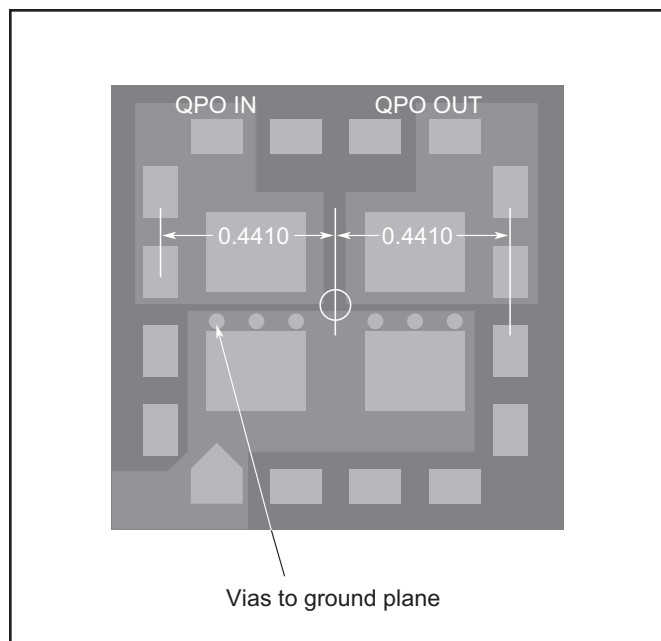

Figure 12 - Recommended PCB copper lands for low thermal resistance.

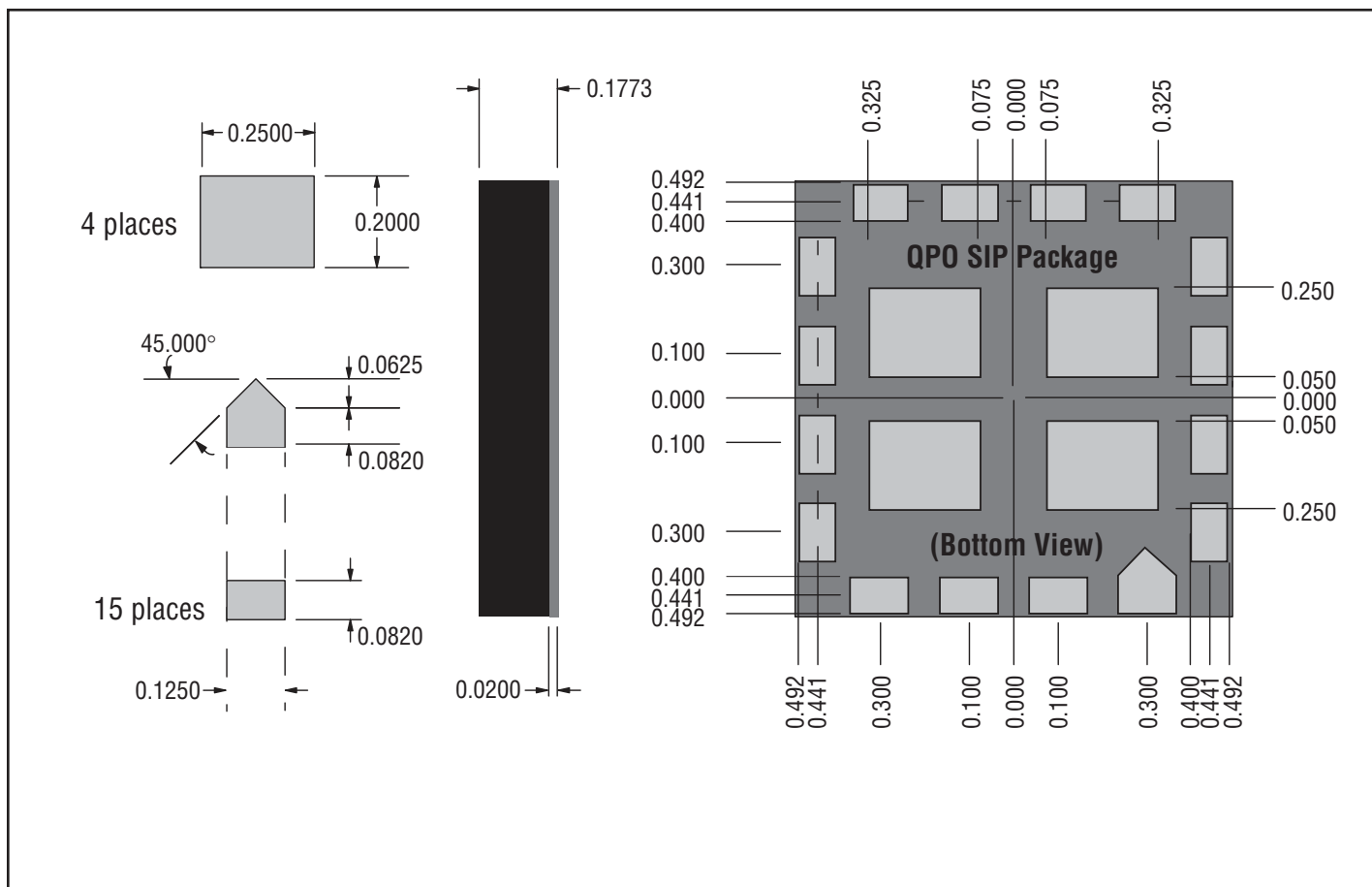

Figure 13 - Package dimensions (dimensions in inches)

Post Solder Cleaning

Picor lidded QP SIPs are not hermetically sealed and must not be exposed to liquid, including but not limited to cleaning solvents, aqueous washing solutions or pressurized sprays.

When soldering, it is recommended that no-clean flux solder be used, as this will insure that potentially corrosive mobile ions will not remain on, around, or under the module following the soldering process.

For applications requiring water wash compatibility the "-01" open frame version should be used.

Ordering Information

Part Number	Description
QPO-2LZ	QPO-2 LGA Package, RoHS Compliant
QPO-2LZ-01	QPO-2 LGA, RoHS Compliant Open Frame Package

End of Life

Vicor's comprehensive line of power solutions includes high-density AC-DC & DC-DC modules and accessory components, fully configurable AC-DC & DC-DC power supplies, and complete custom power systems.

Information furnished by Vicor is believed to be accurate and reliable. However, no responsibility is assumed by Vicor for its use. No license is granted by implication or otherwise under any patent or patent rights of Vicor. Vicor components are not designed to be used in applications, such as life support systems, wherein a failure or malfunction could result in injury or death. All sales are subject to Vicor's Terms and Conditions of Sale, which are available upon request.

Specifications are subject to change without notice.



Vicor Corporation
25 Frontage Road
Andover, MA, USA 01810
Tel: 800-735-6200
Fax: 978-475-6715

Email

Vicor Express: vicorexp@vicr.com
Technical Support: apps@vicr.com