



NOTES: UNLESS OTHERWISE SPECIFIED

1. THIS COMPONENT CONFORMS TO UL60950, UL FILE NO. IS: E216117.

	WARNING: THIS COMPONENT IS RECOGNIZED BY ONE OR MORE SAFETY AGENCIES SUCH AS UL, VDE, CSA AND/OR TUV. ALL ENGINEERING CHANGES MUST HAVE PRIOR APPROVAL BY THE DESIGN CENTER QUALITY DEPARTMENT FOR SAFETY AGENCY COMPLIANCE.	ECN APPROVAL: QA APPROVAL: DATE:

2. **NOTICE:** THIS IS A RoHS COMPLIANT COMPONENT/PRODUCT. ALL ENGINEERING CHANGES MUST HAVE PRIOR APPROVAL BY THE DESIGN CENTER.

	NOTICE: THIS IS A RoHS COMPLIANT COMPONENT/PRODUCT. ALL ENGINEERING CHANGES MUST HAVE PRIOR APPROVAL BY THE DESIGN CENTER.

3. PLASTIC HOUSING: THERMOPLASTIC MATERIAL WITH FLAMMABILITY RATING UL 94V-0 OR BETTER.
4. CONTACT BASE MATERIAL: PHOSPHOR BRONZE.
5. CONTACTS UNDERPLATE: 50 MICROINCHES DUCTILE NICKEL.
6. CONTACTS PLATING: 30 MICROINCHES GOLD PLATING.
7. SOLDER TAIL PLATING MATERIAL: 150-300 MICROINCHES 100% TIN, MATTE FINISH.
8. METAL SHIELD: NICKEL PLATING ON COPPER ALLOY.
9. JACK CAVITY CONFORMS TO FCC RULES AND REGULATIONS PART 68 SUBPART F.
10. PCB PLATING: ENIG
11. SOLDERABILITY: CONFORMS TO ANSI/J-STD-002, IPC/EIA J-STD-003A.
12. OPERATING TEMPERATURE: 0°C TO +70°C
13. STORAGE TEMPERATURE: -20°C TO +125°C
14. JEDEC MOISTURE: LEVEL 1.
15. DIMENSIONS ARE IN INCHES [MILLIMETERS] WITH THE FOLLOWING TOLERANCES: [MILLIMETERS] ARE FOR REFERENCE ONLY.
 .XX= ±0.02 [±0.5]
 .XXX= ±0.010 [±0.25]

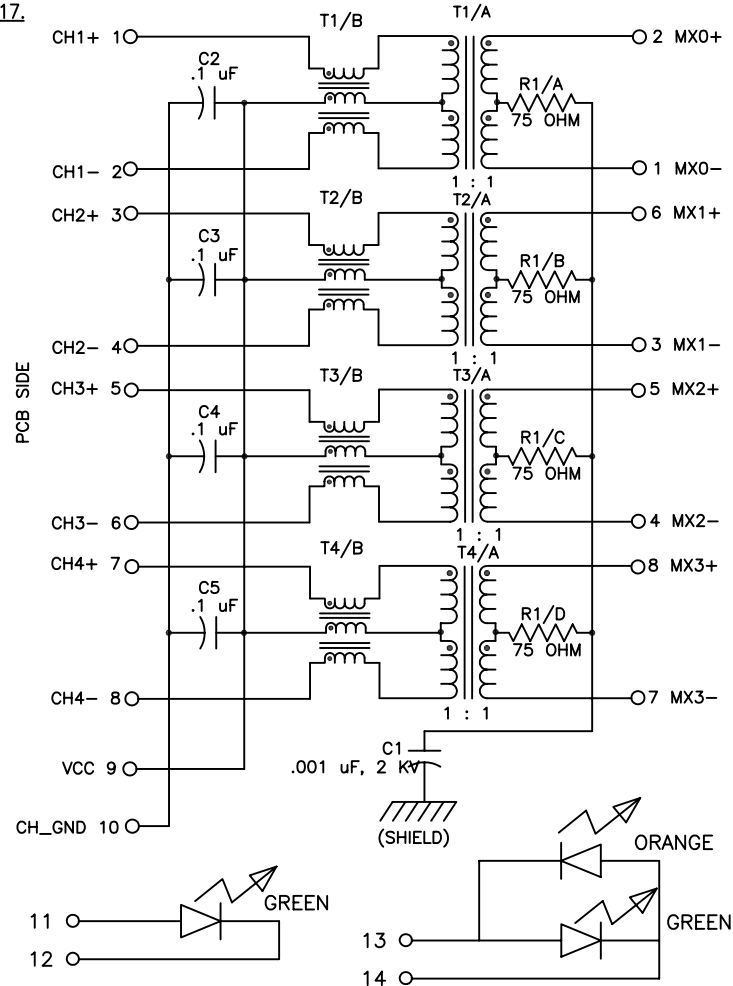

SCHEMATIC

ELECTRICAL CHARACTERISTICS AT +25°C UNLESS OTHERWISE SPECIFIED (FOR REFERENCE ONLY. USED FOR CUSTOMER INFORMATION.)

PARAMETER	SPECIFICATIONS	
OPERATING TEMP	0°C - 70°C	
URNS RATIO	1 : 1 ±2%	
POLARITY	PER SCHEMATIC	
INSERTION LOSS	100 KHz	1-125 MHz
	-1.2 dB MAX	-0.2-0.002*f ^{1.4} dB MAX
RETURN LOSS (Z OUT = 100 OHM ±15%)	.1-40 MHz	40-100 MHz
	-16 dB MIN	-10+20*LOG ₁₀ (f/80 MHz) dB MIN
INDUCTANCE (OCL) (MEDIA SIDE, 0°C-70°C)	350 uH MIN (MEASURED AT 100 KHz, 100 mVRMS AND WITH 8 mA DC BIAS)	
	1 MHz	10-100 MHz
CROSSTALK, ADJACENT CHANNELS	-50 dB MIN	-55+22*LOG ₁₀ (f/10) dB MIN
	2 MHz	30-200 MHz
COMMON MODE REJECTION RATIO	-50 dB MIN	-15+20*LOG ₁₀ (f/200) dB MIN
	1500 VRMS MIN @ 60 SECONDS	

NOTE: f IS FREQUENCY IN MHZ.

EMMITTED COLOR	GREEN	GREEN	ORANGE
WAVELENGTH (nm)	568 nm	568 nm	610 nm
BRIGHTNESS (mCD)	12 TYP. @ 20mA	8.5 TYP. @ 20mA	6.0 TYP. @ 20mA
VIEWING ANGLE	100°	100°	100°
POWER DISSIPATION (Pd)	68 mW MAX	100 mW MAX	80 mW MAX
DC FORWARD CURRENT	150 mA MAX	150 mA MAX	150 mA MAX
FORWARD VOLTAGE (Vf)	2.2 TO 2.7 VOLTS	2.2 TO 2.6 VOLTS	2.0 TO 2.6 VOLTS

BI-COLOR

© Copyright, 2011. Pulse Electronics Corp. All rights reserved. Drawing specifications subject to change without notice. (06/10/11)

PULSE CONFIDENTIAL & PROPRIETARY	PRODUCT DESCRIPTION	PS DRAWING	SHEET:	DWG. NO./ PART NO.	REV.
	CONN,RJ45,1X6,1GD,1:1,TY	PS-2098.004-K	1	JG0-0070NL	M11

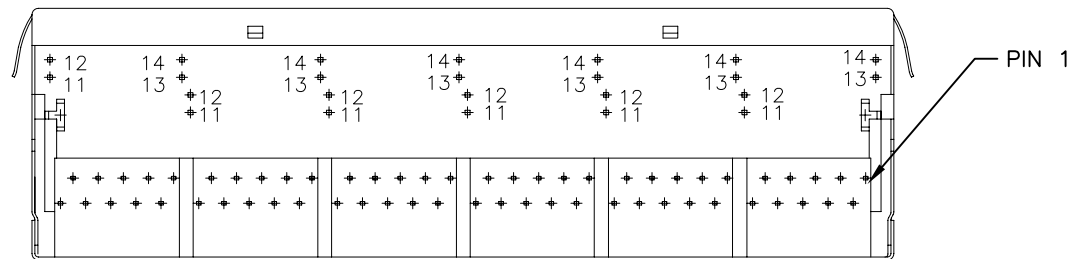
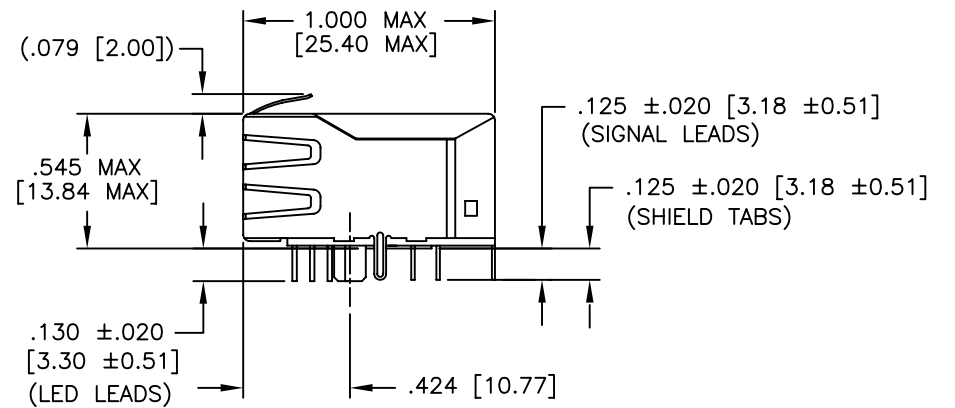
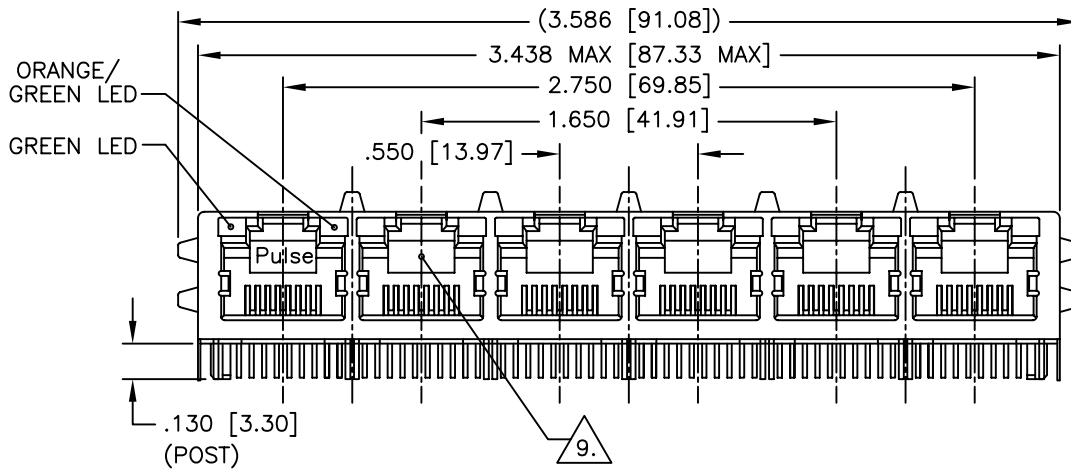
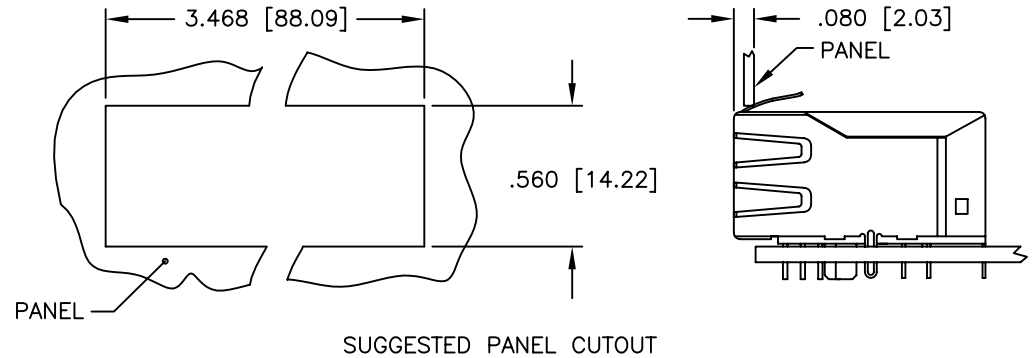
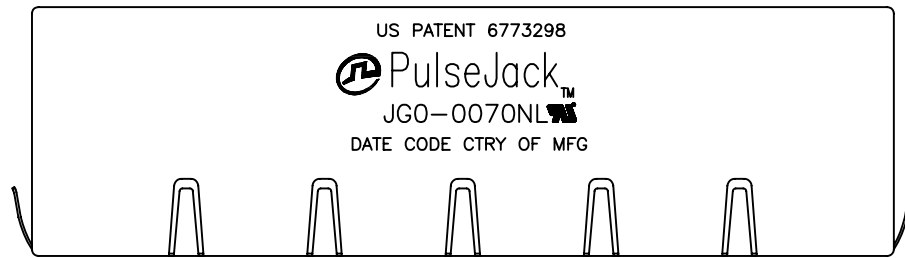

© Copyright, 2011. Pulse Electronics Corp. All rights reserved. Drawing specifications subject to change without notice. (06/10/11)

PULSE CONFIDENTIAL & PROPRIETARY	PRODUCT DESCRIPTION	PS DRAWING	SHEET:	DWG. NO./ PART NO.	REV.
	CONN,RJ45,1X6,1GD,1:1,TY	PS-2098.004-K	2	JGO-0070NL	M11

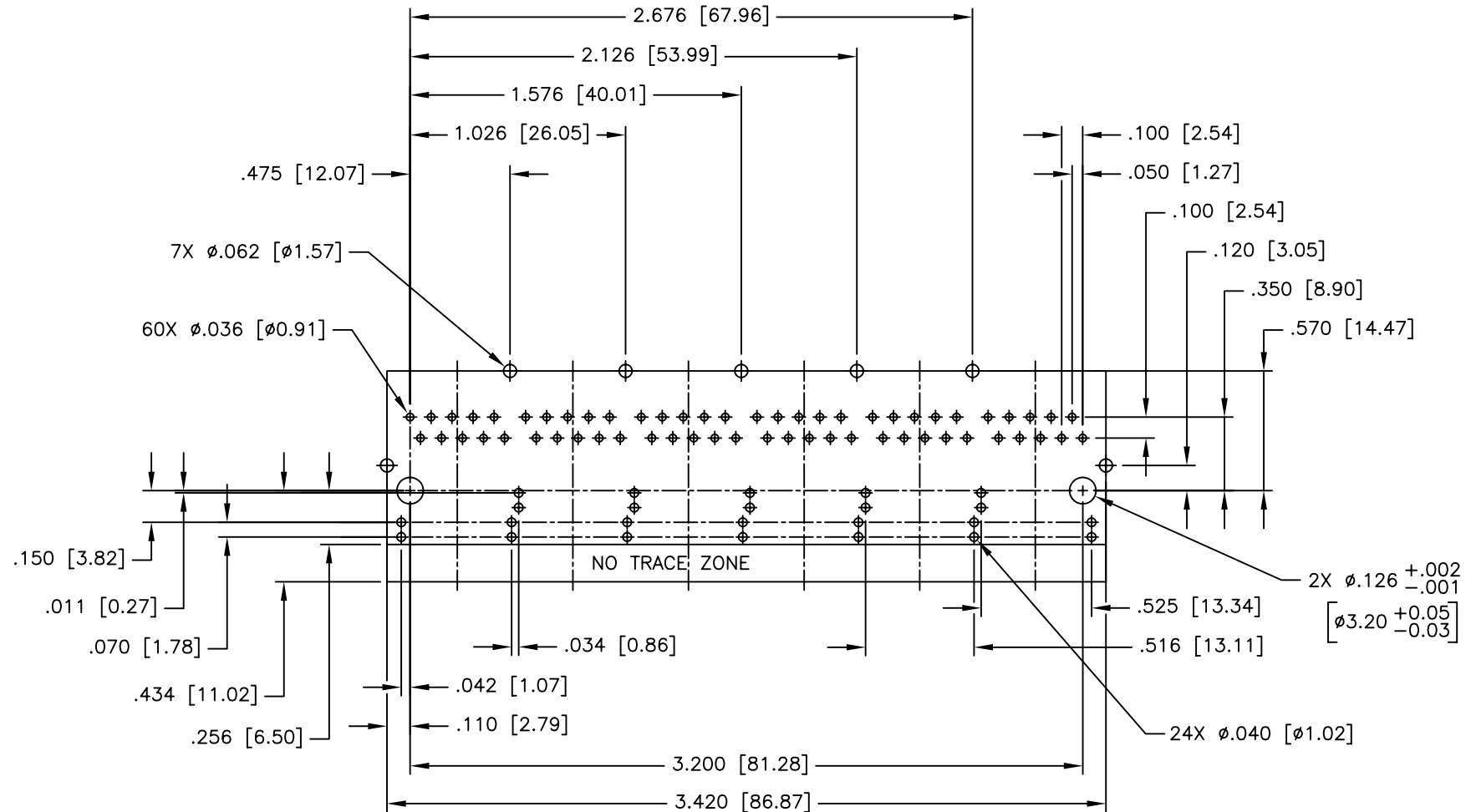

SUGGESTED FOOTPRINT (COMPONENT SIDE SHOWN)
DIMENSIONAL TOLERANCE: (UNLESS OTHERWISE SPECIFIED)
.XXX ± 0.003 [X.XX ± 0.08]

© Copyright, 2011. Pulse Electronics Corp. All rights reserved. Drawing specifications subject to change without notice. (06/10/11)

PULSE CONFIDENTIAL & PROPRIETARY	PRODUCT DESCRIPTION	PS DRAWING	SHEET:	DWG. NO./ PART NO.	REV.
	CONN,RJ45,1X6,1GD,1:1,TY	PS-2098.004-K	3	JG0-0070NL	M11