

High-performance MEMS audio sensor: fully differential analog bottom-port microphone

Datasheet - production data



Features

- Single supply voltage operation
- Fully differential output
- Omnidirectional sensitivity
- High signal-to-noise ratio
- High bandwidth
- Package compliant with reflow soldering
- High RF immunity
- ECOPACK®, RoHS, and “Green” compliant

Description

The MP23AB01DH is a compact, low-power microphone built with a capacitive sensing element and an IC interface.

The sensing element, capable of detecting acoustic waves, is manufactured using a specialized silicon micromachining process to produce audio sensors.

The MP23AB01DH has sensitivity of 38 dB ± 1 dB, an acoustic overload point of 135 dB SPL with minimum 65 dB signal-to-noise ratio.

The MP23AB01DH has fully differential output in order to minimize common mode noise.

The MP23AB01DH is available in a package compliant with reflow soldering and is guaranteed to operate over an extended temperature range from -40 °C to +85 °C.

Table 1: Device summary

Order code	Temp. range (°C)	Package	Packing
MP23AB01DH	-40 to +85	(3.35 x 2.5 x 0.98) mm	Tray
MP23AB01DHTR	-40 to +85	(3.35 x 2.5 x 0.98) mm	Tape and reel

Contents

1 Pin description 3

2 Acoustic and electrical specifications 4

 2.1 Acoustic and electrical characteristics..... 4

 2.2 Frequency response 5

3 Absolute maximum ratings..... 6

4 Application recommendations 7

 4.1 MP23AB01DH schematic hints 7

5 Package information 8

 5.1 Soldering information 8

 5.2 RHLGA 4-lead package information..... 9

6 Reliability tests 10

7 Revision history 11

1 Pin description

Figure 1: Pin connections

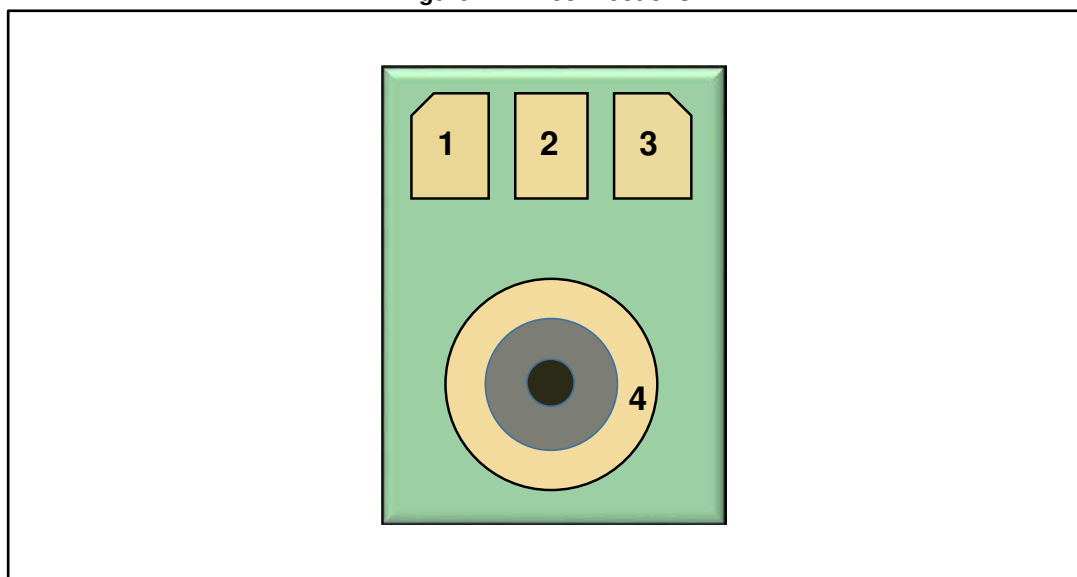

Table 2: Pin description

Pin number	Pin name	Function
1	Vdd	Power supply
2	Output-	Negative output signal
3	Output+	Positive output signal
4	Ground	Ground

2 Acoustic and electrical specifications

2.1 Acoustic and electrical characteristics

The values listed in the table below are specified for Vdd = 2.7 V, No Load, Tamb = 25 °C unless otherwise specified.

Table 3: Acoustic and electrical characteristics

Symbol	Parameter	Test condition	Min.	Typ. ⁽¹⁾	Max.	Unit
Vdd	Supply voltage		2.3	2.7	3.6	V
Idd	Current consumption				250	μA
So	Sensitivity	@1 kHz (0 dB = 1 V/Pa)	-39	-38	-37	dBV
SNR	Signal-to-noise ratio	A-weighted (20 Hz - 20 kHz)	65			dB(A)
PSR	Power supply rejection	100 mVpp sine wave @217 Hz		-100		dB
AOP	Acoustic overload point			135		dB SPL
Zout	Output impedance				400	Ω
Cload	Load capacitance				150	pF
Rload	Load resistance		30			κΩ
Top	Operating temperature range		-40		+85	°C

Notes:

⁽¹⁾Typical specifications are not guaranteed.

Table 4: Typical distortion specifications at 1 kHz sine wave input

Parameter	Test condition	Typ. value
THD+N	94 dB SPL	< 0.2%
	110 dB SPL	< 0.5%
	120 dB SPL	< 3%
	130 dB SPL	< 5%

2.2 Frequency response

Figure 2: Typical free-field frequency response normalized at 1 kHz

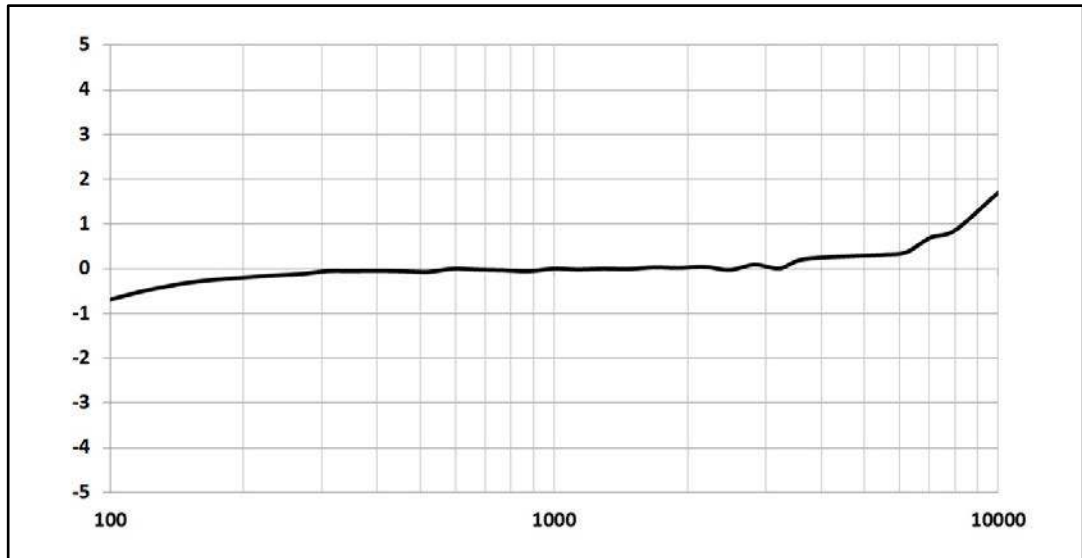

3 Absolute maximum ratings

Stresses above those listed as “Absolute maximum ratings” may cause permanent damage to the device. This is a stress rating only and functional operation of the device under these conditions is not implied. Exposure to maximum rating conditions for extended periods may affect device reliability.

Table 5: Absolute maximum ratings

Symbol	Ratings	Maximum value	Unit
V _{DD}	Supply voltage	-0.5 to 4.8	V
T _{STG}	Storage temperature range	-40 to +105	°C
ESD	(HBM) ANSI/ESDA/JEDEC JS001	±2000	V
ESD	(MM) EIA/JESD22-A115	±200	V
ESD	(CDM) JESD22-C101	±750	V
ESD ⁽¹⁾	Per IEC61000-4-2, 3 discharges, 150 pF, 330 Ω direct contact to housing. MIC must be at zero potential before each discharge.	±8000	V

Notes:

⁽¹⁾Bypass capacitor 200 nF or 1 μF (better), is definitely recommended for ESD main clamp integrity.



This device is sensitive to mechanical shock, improper handling can cause permanent damage to the part.



This device is sensitive to electrostatic discharge (ESD), improper handling can cause permanent damage to the part.

4 Application recommendations

4.1 MP23AB01DH schematic hints

Figure 3: MP23AB01DH electrical connections and external component values

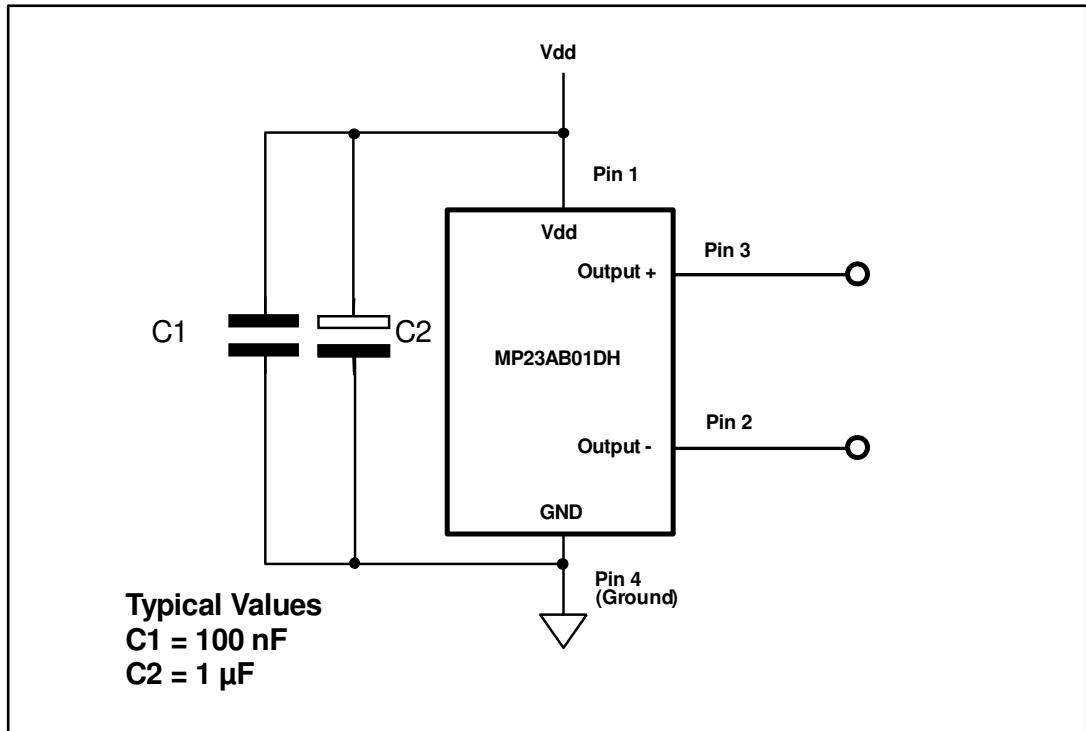

5 Package information

In order to meet environmental requirements, ST offers these devices in different grades of ECOPACK® packages, depending on their level of environmental compliance. ECOPACK® specifications, grade definitions and product status are available at: www.st.com. ECOPACK® is an ST trademark.

5.1 Soldering information

Figure 4: Recommended soldering profile limits

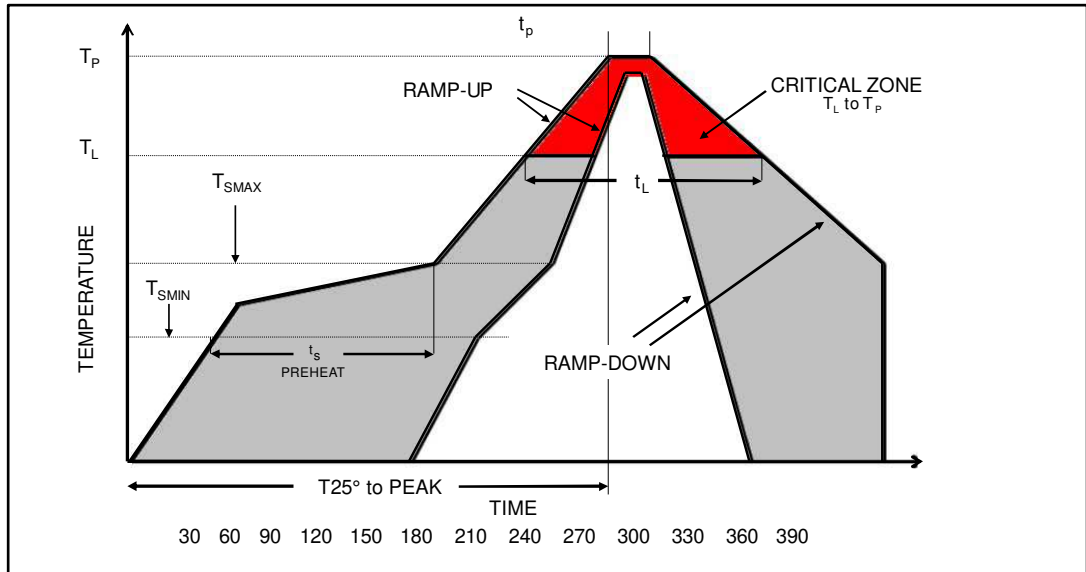
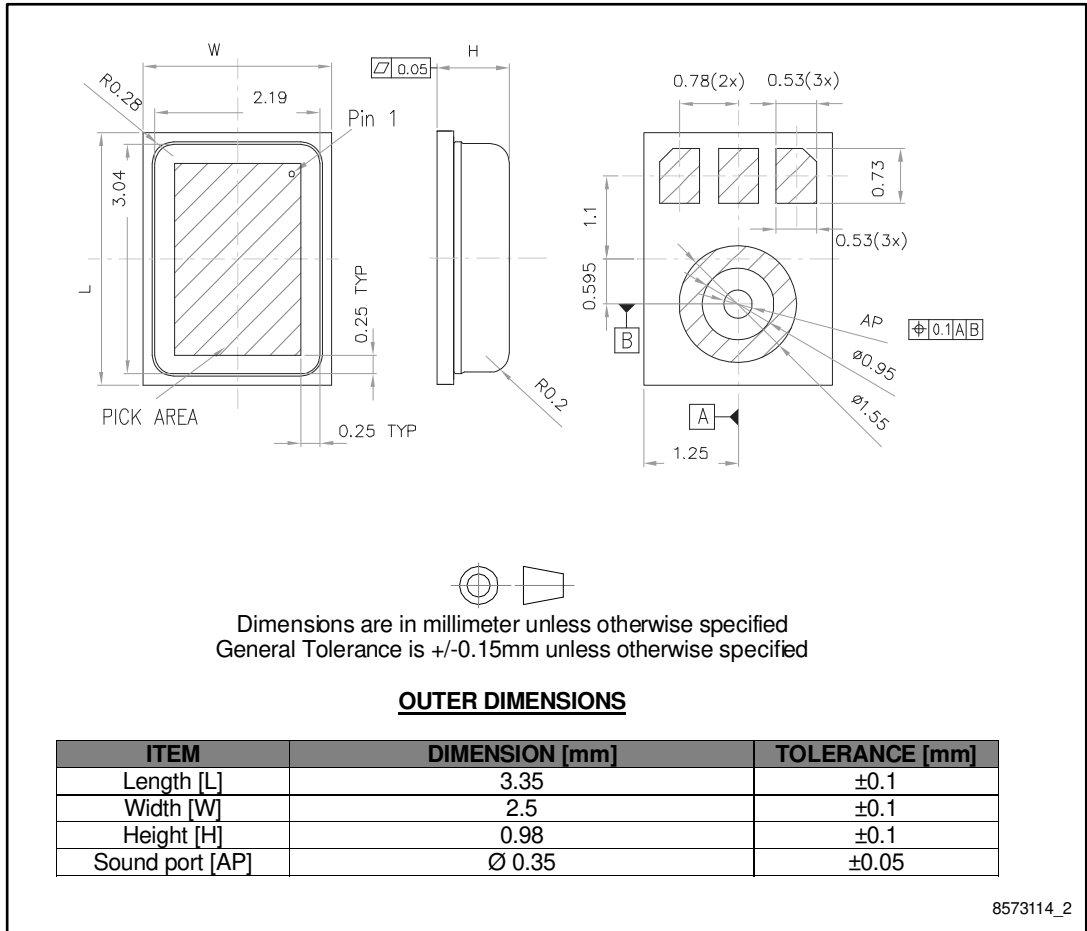

Table 6: Recommended soldering profile limits

Description	Parameter	Pb free
Average ramp rate	T_L to T_P	3 °C/sec max
Preheat	T_{SMIN} T_{SMAX} t_s	150 °C 200 °C 60 sec to 120 sec
Ramp-up rate	T_{SMAX} to T_L	
Time maintained above liquidus temperature Liquidus temperature	t_L T_L	60 sec to 150 sec 217 °C
Peak temperature	T_P	260 °C max
Time within 5 °C of actual peak temperature		20 sec to 40 sec
Ramp-down rate		6 °C/sec max
Time 25 °C ($t = 25$ °C) to peak temperature		8 minutes max

5.2 RHLGA 4-lead package information

Figure 5: RHLGA metal cap 4-lead (3.35 x 2.5 x 0.98 mm) package outline and mechanical dimensions



6 Reliability tests

The device passed all reliability tests on three different assembly lots under the following conditions given in the table below.

Table 7: Tests and summary of results

Test name	Description	Conditions
HTOL: High Temperature Operating Life	The device is stressed in dynamic configuration, approaching the operative max. absolute ratings in terms of junction temperature, load current, internal power dissipation.	Vdd(max) = 3.6 V; Tamb = 125 °C JESD22a108
HTS: High Temperature Storage	The device is stored in an unbiased condition at the maximum temperature allowed by the package materials, sometimes higher than the maximum operative temperature.	Ta = 125 °C JESD22a103
PC (JL3): Preconditioning (solder simulation)	The device is submitted to a typical temperature profile used for surface mounting, after controlled moisture absorption	
TC: Temperature Cycling	The device is submitted to cycled temperature excursions, between a hot and a cold chamber in air atmosphere	Ta Cycling: -40 °C ±125 °C JESD22a104
ESD (HBM): Electrostatic Discharge (Human Body Model)	The device is submitted to a high voltage peak on all his pins simulating ESD stress according to different simulation models.	Voltage ±2000 V JEDEC / JESD22-A114E
ESD (MM): Electrostatic Discharge (Machine Model)		Voltage ±200 V JEDEC/JESD-A115-A
ESD (CDM): Electrostatic Discharge (Charged Device Model)		Voltage ±750 V ANSI / ESD STM 5.3.1 ESDA
LU (CI): Latch-up (Overvoltage and Current Injection)	The device is submitted to a direct current forced/sunk into the input/output pins. Removing the direct current, no change in the supply current must be observed.	Current injection ±200 mA Overvoltage 1.5 x Vmax EIA/JESD78
THB: Temperature Humidity Bias	The device is biased in static configuration minimizing its internal power dissipation, and stored at controlled conditions for ambient temperature and relative humidity.	Vdd(nom) = 2.7 V T = 85 °C / RH = 85% JESD22a108
LTS: Low Temperature Storage	The device is stored in an unbiased condition at the min. temperature allowed by the package materials, sometimes lower than the min. op. temp	Ta = -40 °C JESD22a119
MS: Mechanical Shock	The device is submitted to 10000 g / 0.1 ms 5 shocks for each axis.	10000 g / 0.1 ms 5 shocks for each axis, under bias MIL STD 883MIL

7 Revision history

Table 8: Document revision history

Date	Revision	Changes
17-Nov-2016	1	Initial release
31-Aug-2017	2	Updated <i>Figure 3: "MP23AB01DH electrical connections and external component values"</i>

IMPORTANT NOTICE – PLEASE READ CAREFULLY

STMicroelectronics NV and its subsidiaries ("ST") reserve the right to make changes, corrections, enhancements, modifications, and improvements to ST products and/or to this document at any time without notice. Purchasers should obtain the latest relevant information on ST products before placing orders. ST products are sold pursuant to ST's terms and conditions of sale in place at the time of order acknowledgement.

Purchasers are solely responsible for the choice, selection, and use of ST products and ST assumes no liability for application assistance or the design of Purchasers' products.

No license, express or implied, to any intellectual property right is granted by ST herein.

Resale of ST products with provisions different from the information set forth herein shall void any warranty granted by ST for such product.

ST and the ST logo are trademarks of ST. All other product or service names are the property of their respective owners.

Information in this document supersedes and replaces information previously supplied in any prior versions of this document.

© 2017 STMicroelectronics – All rights reserved