

【1. 適用範囲 SCOPE】

本仕様書は、_____ 殿 に納入する

_____ PicoBlade 1.25 電線対基板 コネクタ (1列 TH R/A 金めっき品) _____ について規定する。

This product specification covers the performance requirements for PicoBlade 1.25 WIRE TO BOARD CONNECTOR (SINGLE-ROW TH R/A GOLD PLATING TYPE) series for use by _____.

【2. 製品名称及び型番 PRODUCT NAME AND PART NUMBER】

| 製品名称 Product Name | | 金めっき厚 Gold Plating Thickness | 製品型番 Part Number | 図面番号 Drawing Number |
|---|-----------------------|---------------------------------|---------------------|------------------------|
| リセプタクル クリンプターミナル Receptacle Crimp Terminal | AWG #28-#32 | FLASH | 500588020 | 500580000-SD 000 |
| | | 0.38 micro-meters MIN | 500588025 | |
| | AWG #26-#28 | FLASH | 500798020 | 500790000-SD 000 |
| | | 0.38 micro-meters MIN | 500798025 | |
| リセプタクル ハウジング Receptacle Housing | | | 51021 * * 00 | 510210000-SD 000 |
| プラグ アセンブリ (ライトアングルタイプ) Plug Assembly (Right Angle type) | FLASH | | 53048 * * 60 | 530480000-SD 000 |
| | 0.38 micro-meters MIN | | 53048 * * 50 | |

* : 図面参照 Refer to the drawing.

取扱についてはコネクタ取扱説明書510210000-AS PS 000参照願います。
Instruction manual : Refer to Application specification 510210000-AS PS 000

THIS DOCUMENT CONTAINS INFORMATION THAT IS PROPRIETARY TO MOLEX ELECTRONIC TECHNOLOGIES, LLC AND SHOULD NOT BE USED WITHOUT WRITTEN PERMISSION

| REVISION DESCRIPTION | REVISED | | | PRODUCT SPECIFICATION FOR PICOBLADE 1.25 W/B TH RA TYPE GOLD PLATING CONNECTOR | | | | | |
|----------------------|----------|------|------------|---|--------------------------------|-----------------|----------|----------|---------|
| CHANGE NO. | 702978 | | | | | | | | |
| REVISED BY | QHE31 | DATE | 2022/03/11 | DOC TYPE | DOC TYPE DESCRIPTION | | DOC PART | SERIES | |
| REV APPR BY | SAKIYAMA | DATE | 2022/05/12 | PS | ENGINEERING SPECIFICATION WORD | | 000 | 51021 | |
| INITIAL RELEASE | | | | CUSTOMER | | DOCUMENT NUMBER | | REVISION | SHEET |
| INITIAL DRWN | SOBARA01 | DATE | 2017/10/12 | GENERAL | | 510210000-PS | | F | 1 OF 17 |
| INITIAL APPR | TKANEKO | DATE | 2018/10/30 | | | | | | |

【3. 定格及び適用電線 RATINGS AND APPLICABLE WIRES】

| 項目 Item | 規格 Standard | | |
|---|--------------------------------|-------|--|
| 最大許容電圧 Rated Voltage (MAX) | 125 V (実効値 rms) | | [AC(実効値 rms)rms/ DC] |
| 最大許容電流 及び適用電線 Rated Current (MAX) and Applicable wires | AWG #26 | 1.0 A | 被覆外径 ^{*4} Insulation Diameter ^{*4} 50058802* : ϕ 1.0mm MAX 50079802* : ϕ 1.04mm MAX |
| | AWG #28 | 1.0 A | |
| | AWG #30 | 1.0 A | |
| | AWG #32 | 0.8 A | |
| 使用温度範囲 ^{*1} Ambient Temperature Range ^{*1} | -40°C ~ +105°C ^{*2*3} | | |

*1: 基板実装後の無通電状態は、使用温度範囲が適用されます。

Non-operating connectors after reflow must follow the operating temperature range condition.

*2: 通電による温度上昇分も含む。Including terminal temperature rise.

*3: 適合電線も本使用温度範囲を満足すること。

Applicable wires must also meet the specified temperature range.

*4: 本仕様書は、端子のアプリケーションツール仕様を提供していません。適合アプリケーションツール仕様は Molex.comの端子型番ページからご参照ください。

Application Tooling Specification for terminals is not provided in this document. ATS for terminals can be available from respective terminal part number page in Molex.com.

参考許容電流 CURRENT DERATING REFERENCE INFORMATION

| AWG | 2-circuits | 8-circuits | 15-circuits |
|-----|-------------|-------------|-------------|
| | Current (A) | Current (A) | Current (A) |
| 26 | 2.5 | 1.5 | 1.0 |
| 28 | 2.0 | 1.5 | 1.0 |
| 30 | 1.5 | 1.0 | 1.0 |
| 32 | 1.5 | 1.0 | 0.8 |

1) 各電流値は参考となります。

Values are for REFERENCE ONLY

1) 閾値は温度上昇30°C以下としています。

Current deratings are based on not exceeding 30°C Temperature Rise.

2) 温度上昇の測定は圧着端子のバレル部にて実施しています。

Temperature Rise is measured in barrel area of crimp terminal.

3) 基板デザインにより温度上昇の結果が異なります。

PCB trace design can greatly affect temperature rise results.

4) 全極に通電し測定しています。

Data is for all circuits powered.

THIS DOCUMENT CONTAINS INFORMATION THAT IS PROPRIETARY TO MOLEX ELECTRONIC TECHNOLOGIES, LLC AND SHOULD NOT BE USED WITHOUT WRITTEN PERMISSION

| REVISION DESCRIPTION | REVISED | PRODUCT SPECIFICATION FOR PICOBLADE 1.25 W/B TH RA TYPE GOLD PLATING CONNECTOR | | | | | |
|----------------------|----------|---|------------|----------|--------------------------------|----------|---------|
| CHANGE NO. | 702978 | | | | | | |
| REVISED BY | QHE31 | DATE | 2022/03/11 | DOC TYPE | DOC TYPE DESCRIPTION | DOC PART | SERIES |
| REV APPR BY | SAKIYAMA | DATE | 2022/05/12 | PS | ENGINEERING SPECIFICATION WORD | 000 | 51021 |
| INITIAL RELEASE | | | | CUSTOMER | DOCUMENT NUMBER | REVISION | SHEET |
| INITIAL DRWN | SOBARA01 | DATE | 2017/10/12 | GENERAL | 51021000-PS | F | 2 OF 17 |
| INITIAL APPR | TKANEKO | DATE | 2018/10/30 | | | | |

【4. 性能 PERFORMANCE】

4-1. 電氣的性能 Electrical Performance

| 項目 Item | | 条件 Test Condition | 規格 Requirement |
|------------|--|--|---|
| 4-1-1 | 接触抵抗 Contact Resistance | コネクタを嵌合させ、開放電圧 20mV 以下、短絡電流 10mA 以下にて測定する。(JIS C5402-2-1) Mate connectors, and measure by dry circuit, 20mV MAX, 10mA MAX (JIS C5402-2-1) | 20 milliohms MAX |
| 4-1-2 | 絶縁抵抗 Insulation Resistance | コネクタを嵌合させ、隣接するターミナル間 及びターミナル、アース間に、DC 500V を印加し測定する。(JIS C5402-3-1/MIL-STD-202 試験法 302) Mate connectors, apply 500V DC between adjacent terminal or ground (JIS C5402-3-1/MIL-STD-202 Method 302) | 100 Megaohms MIN |
| 4-1-3 | 耐電圧 Dielectric Strength | コネクタを嵌合させ、隣接するターミナル間 及びターミナル、アース間に、AC(rms) 250V (実効値) を 1分間 印加する。(JIS C5402-4-1/MIL-STD-202 試験法 301) Mate connectors, apply 250V AC(rms) for 1 minute between adjacent terminal or ground. (JIS C5402-4-1/MIL-STD-202 Method 301) | 製品機能を損なう 異常なきこと No Damage on function |
| 4-1-4 | 圧着部接触抵抗 Contact Resistance on Crimped Portion | ターミナルに適合電線を圧着し、開放電圧20mV以下、短絡電流 10mA 以下にて測定する。 Crimp the applicable wire to the terminal, measured by dry circuit, 20mV MAX, 10 mA MAX. | 5 milliohms MAX |

THIS DOCUMENT CONTAINS INFORMATION THAT IS PROPRIETARY TO MOLEX ELECTRONIC TECHNOLOGIES, LLC AND SHOULD NOT BE USED WITHOUT WRITTEN PERMISSION

| REVISION DESCRIPTION | REVISED | PRODUCT SPECIFICATION FOR PICOBLADE 1.25 W/B TH RA TYPE GOLD PLATING CONNECTOR | | | | | |
|----------------------|----------|---|------------|----------|--------------------------------|----------|---------|
| CHANGE NO. | 702978 | | | | | | |
| REVISED BY | QHE31 | DATE | 2022/03/11 | DOC TYPE | DOC TYPE DESCRIPTION | DOC PART | SERIES |
| REV APPR BY | SAKIYAMA | DATE | 2022/05/12 | PS | ENGINEERING SPECIFICATION WORD | 000 | 51021 |
| INITIAL RELEASE | | | | CUSTOMER | DOCUMENT NUMBER | REVISION | SHEET |
| INITIAL DRWN | SOBARA01 | DATE | 2017/10/12 | GENERAL | 510210000-PS | F | 3 OF 17 |
| INITIAL APPR | TKANEKO | DATE | 2018/10/30 | | | | |

4-2. 機械的性能 Mechanical Performance

| 項目 Item | | 条件 Test Condition | 規格 Requirement | |
|------------|---|---|--------------------------------|---------------------|
| 4-2-1 | 挿入力 及び抜去力 Insertion and Withdrawal Force | 毎分 25±3mm の速さで挿入、抜去を 行う。 Insert and withdraw connectors at the speed rate of 25±3mm/minute. | 第 6 参照 Refer to paragraph 6 | |
| 4-2-2 | 圧着部引張強度 Crimping Pull out Force | 圧着されたターミナルを治具に固定し、 電線を軸方向に毎分25±3mmの速さで引 張る。 (JIS C5402-16-4) Fix the crimped terminal to the jig, apply axial pull out force on the wire at the speed rate of 25±3 mm/minute. (JIS C5402-16-4) | AWG #26 | 19.6 N {2.0kgf} MIN |
| | | | AWG #28 | 9.8 N {1.0kgf} MIN |
| | | | AWG #30 | 4.9 N {0.5kgf} MIN |
| | | | AWG #32 | 3.4 N {0.3kgf} MIN |
| 4-2-3 | 圧着端子挿入力 Crimp Terminal Insertion Force | 圧着されたターミナルをハウジングに挿入 する。 Insert the crimped terminal into the housing. | 4.9 N {0.5kgf} MAX | |
| 4-2-4 | 圧着端子保持力 Crimp Terminal Retention Force | 圧着されたターミナルをハウジングに装着 し、 電線を軸方向に毎分 25±3mm の速さで 引張る。 Apply axial pull out force to the terminal assembled in the housing at the speed rate of 25±3mm/minute. | 4.9 N {0.5kgf} MIN | |
| 4-2-5 | HDR端子保持力 Header Terminal Retention Force | ハウジングに圧入されたターミナルを毎分 25±3mm の速さで軸方向に押す。 Apply axial push out force at the speed rate of 25±3 mm/minute on the terminal assembled in the housing. | 4.9 N {0.5kgf} MIN | |

THIS DOCUMENT CONTAINS INFORMATION THAT IS PROPRIETARY TO MOLEX ELECTRONIC TECHNOLOGIES, LLC AND SHOULD NOT BE USED WITHOUT WRITTEN PERMISSION

| | | | | | | | |
|----------------------|----------|---|------------|----------|--------------------------------|----------|---------|
| REVISION DESCRIPTION | REVISED | PRODUCT SPECIFICATION FOR PICOBLADE 1.25 W/B TH RA TYPE GOLD PLATING CONNECTOR | | | | | |
| CHANGE NO. | 702978 | | | | | | |
| REVISED BY | QHE31 | DATE | 2022/03/11 | DOC TYPE | DOC TYPE DESCRIPTION | DOC PART | SERIES |
| REV APPR BY | SAKIYAMA | DATE | 2022/05/12 | PS | ENGINEERING SPECIFICATION WORD | 000 | 51021 |
| INITIAL RELEASE | | | | CUSTOMER | DOCUMENT NUMBER | REVISION | SHEET |
| INITIAL DRWN | SOBARA01 | DATE | 2017/10/12 | GENERAL | 51021000-PS | F | 4 OF 17 |
| INITIAL APPR | TKANEKO | DATE | 2018/10/30 | | | | |

4-3. 環境性能、その他 Environmental Performance and Others

| 項目 Item | | 条件 Test Condition | 規格 Requirement | |
|------------|---|---|----------------------------|---|
| 4-3-1 | 繰り返し挿抜 Repeated Insertion/ Withdrawal | 1分間10回以下の速さで、挿入、抜去を30回繰返す。 Insert and withdraw connectors 30 cycles repeatedly by rate of less than 10 cycles per minute. | 接触抵抗 Contact Resistance | 40 milliohms MAX |
| 4-3-2 | 温度上昇 Temperature Rise | コネクタを嵌合させ、全ての圧着端子を直列に接続し最大許容電流で熱平衡に達した時の温度上昇を測定する。(UL498) Mate connectors and all crimp terminals shall be connected in a direct series. The temperature rise shall be measured when the terminal reaches terminal equilibrium allowable current. (UL498) | 温度上昇 Temperature Rise | 30°C MAX |
| 4-3-3 | 耐振動性 Vibration | コネクタを嵌合させ、DC 1mA 通電状態にて、嵌合軸を含む互いに垂直な3方向に掃引割合 10~55~10 Hz/分、全振幅 1.5mm の振動を各2時間加える。(ケーブルは固定すること) (JIS C 60068-2-6/MIL-STD-202 試験法 201) Mate connectors and subject to the following vibration conditions, for a period of 2 hours in each of 3 mutually perpendicular axes, passing DC 1mA during the test. (Fix the cable at test.) Amplitude : 1.5mm P-P Frequency : 10~55~10 Hz in 1 minute. Duration : 2 hours in each X Y Z axes. (JIS C 60068-2-6/MIL-STD-202 Method 201) | 外観 Appearance | 製品機能を損なう異常なきこと No Damage on function |
| | | | 接触抵抗 Contact Resistance | 40 milliohms MAX |
| | | | 瞬断 Discontinuity | 1.0 microsecond MAX |
| 4-3-4 | 耐衝撃性 Mechanical Shock | コネクタを嵌合させ、DC 1mA 通電状態にて、テストパルス半周期、嵌合軸を含む互いに垂直な6方向に 490m/s ² { 50G }、作用時間 11msの衝撃を各3回、合計18回加える。 (JIS C60068-2-27/MIL-STD-202 試験法 213) Mate connectors and subject to the following shock conditions. 3 shocks shall be applied along 3 mutually perpendicular axes, passing DC 1 mA current during the test. (Total of 18 shocks) Test pulse : Half Sine Peak value : 490 m/s ² (50 G) Duration : 11 ms (JIS C60068-2-27/MIL-STD-202 Method 213) | 外観 Appearance | 製品機能を損なう異常なきこと No Damage on function |
| | | | 接触抵抗 Contact Resistance | 40 milliohms MAX |
| | | | 瞬断 Discontinuity | 1.0 microsecond MAX |

THIS DOCUMENT CONTAINS INFORMATION THAT IS PROPRIETARY TO MOLEX ELECTRONIC TECHNOLOGIES, LLC AND SHOULD NOT BE USED WITHOUT WRITTEN PERMISSION

| | | | | | | | |
|----------------------|----------|---|------------|----------|--------------------------------|----------|---------|
| REVISION DESCRIPTION | REVISED | PRODUCT SPECIFICATION FOR PICOBLADE 1.25 W/B TH RA TYPE GOLD PLATING CONNECTOR | | | | | |
| CHANGE NO. | 702978 | | | | | | |
| REVISED BY | QHE31 | DATE | 2022/03/11 | DOC TYPE | DOC TYPE DESCRIPTION | DOC PART | SERIES |
| REV APPR BY | SAKIYAMA | DATE | 2022/05/12 | PS | ENGINEERING SPECIFICATION WORD | 000 | 51021 |
| INITIAL RELEASE | | | | CUSTOMER | DOCUMENT NUMBER | REVISION | SHEET |
| INITIAL DRWN | SOBARA01 | DATE | 2017/10/12 | GENERAL | 51021000-PS | F | 5 OF 17 |
| INITIAL APPR | TKANEKO | DATE | 2018/10/30 | | | | |

| 項目 Item | | 条件 Test Condition | 規格 Requirement | |
|------------|------------------------|--|-------------------------------|---|
| 4-3-5 | 耐熱性 Heat Resistance | コネクタを嵌合させ、105±2°Cの雰囲気中に96時間放置後取り出し、1~2時間室温に放置する。 (JIS C60068-2-2/MIL-STD-202 試験法 108) Mate connectors and expose to 105±2°C for 96 hours. Upon completion of the exposure period, the test specimens shall be conditioned at ambient room conditions for 1 to 2 hours, after which the specified measurements shall be performed. (JIS C60068-2-2/MIL-STD-202 Method 108) | 外観 Appearance | 製品機能を損なう異常なきこと No Damage on function |
| | | | 接触抵抗 Contact Resistance | 40 milliohms MAX |
| 4-3-6 | 耐寒性 Cold Resistance | コネクタを嵌合させ、-40±3°Cの雰囲気中に96時間放置後取り出し、1~2時間室温に放置する。(JIS C60068-2-1) Mate connectors and expose to -40±3°C for 96 hours. Upon completion of the exposure period, the test specimens shall be conditioned at ambient room conditions for 1 to 2 hours, after which the specified measurements shall be performed. (JIS C60068-2-1) | 外観 Appearance | 製品機能を損なう異常なきこと No Damage on function |
| | | | 接触抵抗 Contact Resistance | 40 milliohms MAX |
| 4-3-7 | 耐湿性 Humidity | コネクタを嵌合させ、60±2°C、相対湿度90~95%の雰囲気中に96時間放置後取り出し、1~2時間室温に放置する。 (JIS C60068-2-78/MIL-STD-202 試験法 103) Mate connectors and expose to 60±2°C, relative humidity 90 to 95% for 96 hours. Upon completion of the exposure period, the test specimens shall be conditioned at ambient room conditions for 1 to 2 hours, after which the specified measurements shall be performed. (JIS C60068-2-78/MIL-STD-202 Method 103) | 外観 Appearance | 製品機能を損なう異常なきこと No Damage on function |
| | | | 接触抵抗 Contact Resistance | 40 milliohms MAX |
| | | | 絶縁抵抗 Insulation Resistance | 10 Megaohms MIN |
| | | | 耐電圧 Dielectric Strength | 4-1-3項を満足のこと Must meet 4-1-3 |

THIS DOCUMENT CONTAINS INFORMATION THAT IS PROPRIETARY TO MOLEX ELECTRONIC TECHNOLOGIES, LLC AND SHOULD NOT BE USED WITHOUT WRITTEN PERMISSION

| | | | | | | | |
|----------------------|----------|---|------------|----------|--------------------------------|----------|---------|
| REVISION DESCRIPTION | REVISED | PRODUCT SPECIFICATION FOR PICOBLADE 1.25 W/B TH RA TYPE GOLD PLATING CONNECTOR | | | | | |
| CHANGE NO. | 702978 | | | | | | |
| REVISED BY | QHE31 | DATE | 2022/03/11 | DOC TYPE | DOC TYPE DESCRIPTION | DOC PART | SERIES |
| REV APPR BY | SAKIYAMA | DATE | 2022/05/12 | PS | ENGINEERING SPECIFICATION WORD | 000 | 51021 |
| INITIAL RELEASE | | | | CUSTOMER | DOCUMENT NUMBER | REVISION | SHEET |
| INITIAL DRWN | SOBARA01 | DATE | 2017/10/12 | GENERAL | 51021000-PS | F | 6 OF 17 |
| INITIAL APPR | TKANEKO | DATE | 2018/10/30 | | | | |

| 項目 Item | | 条件 Test Condition | 規格 Requirement | |
|------------|----------------------------------|--|----------------------------------|---|
| 4-3-8 | 温度サイクル Temperature Cycling | コネクタを嵌合させ、 $-55\pm 3^{\circ}\text{C}$ に30分、 $+105\pm 2^{\circ}\text{C}$ に30分。これを1サイクルとし、5サイクル繰返す。但し、温度移行時間は5分以内とする。 試験後1~2時間 室温に放置する。 (JIS C60068-2-14) Mate connectors and subject to the following conditions for 5 cycles. Upon completion of the exposure period, the test specimens shall be conditioned at ambient room conditions for 1 to 2 hours, after which the specified measurements shall be performed. 5 cycles of : a) $-55\pm 3^{\circ}\text{C}$ 30 minutes b) $+105\pm 2^{\circ}\text{C}$ 30 minutes Shift time : Within 5 minutes (JIS C60068-2-14) | 外 観 Appearance | 製品機能を損なう異常なきこと No Damage on function |
| | | | 接 触 抵 抗 Contact Resistance | 40 milliohms MAX |
| 4-3-9 | 塩水噴霧 Salt Spray | コネクタを嵌合させ、 $35\pm 2^{\circ}\text{C}$ にて $5\pm 1\%$ 重量比の塩水を48±4時間噴霧し、試験後常温で水洗いした後、室温で乾燥させる。 (JIS C60068-2-11/MIL-STD-202 試験法101) Mate connectors and expose to the following salt mist conditions. Upon completion of the exposure period, salt deposits shall be removed by a gentle wash or dip in running water, after which the specified measurements shall be performed. NaCl solution Concentration : $5\pm 1\%$ Spray time : 48 ± 4 hours Ambient temperature : $35\pm 2^{\circ}\text{C}$ (JIS 60068-2-11/MIL-STD-202 Method 101) | 外 観 Appearance | 製品機能を損なう異常なきこと No Damage on function |
| | | | 接 触 抵 抗 Contact Resistance | 40 milliohms MAX |

THIS DOCUMENT CONTAINS INFORMATION THAT IS PROPRIETARY TO MOLEX ELECTRONIC TECHNOLOGIES, LLC AND SHOULD NOT BE USED WITHOUT WRITTEN PERMISSION

| | | | | | | | |
|----------------------|----------|---|------------|----------|--------------------------------|----------|---------|
| REVISION DESCRIPTION | REVISED | PRODUCT SPECIFICATION FOR PICOBLADE 1.25 W/B TH RA TYPE GOLD PLATING CONNECTOR | | | | | |
| CHANGE NO. | 702978 | | | | | | |
| REVISED BY | QHE31 | DATE | 2022/03/11 | DOC TYPE | DOC TYPE DESCRIPTION | DOC PART | SERIES |
| REV APPR BY | SAKIYAMA | DATE | 2022/05/12 | PS | ENGINEERING SPECIFICATION WORD | 000 | 51021 |
| INITIAL RELEASE | | | | CUSTOMER | DOCUMENT NUMBER | REVISION | SHEET |
| INITIAL DRWN | SOBARA01 | DATE | 2017/10/12 | GENERAL | 51021000-PS | F | 7 OF 17 |
| INITIAL APPR | TKANEKO | DATE | 2018/10/30 | | | | |

| 項目 Item | | 条件 Test Condition | 規格 Requirement | |
|------------|--------------------------------|--|-------------------------------|---|
| 4-3-10 | 耐亜硫酸ガス SO ₂ Gas | コネクタを嵌合させ、40±2°Cにて50±5ppmの亜硫酸ガス中に24時間放置する。 Mated connectors and expose to the conditions of 50±5ppm SO ₂ gas ambient temperature 40±2°C for 24 hours. | 外 観 Appearance | 製品機能を損なう異常なきこと No Damage on function |
| | | | 接 触 抵 抗 Contact Resistance | 40 milliohms MAX |
| 4-3-11 | 耐アンモニア性 NH ₃ Gas | コネクタを嵌合させ、濃度28%のアンモニア水を入れた容器中に40分間放置する。 (1Lに対して25mLの割合) Mated connectors and expose to the conditions of NH ₃ gas evaporating from 28% NH ₃ solution for 40 minutes. (Rate is 25ml per 1L) | 外 観 Appearance | 製品機能を損なう異常なきこと No Damage on function |
| | | | 接 触 抵 抗 Contact Resistance | 40 milliohms MAX |

THIS DOCUMENT CONTAINS INFORMATION THAT IS PROPRIETARY TO MOLEX ELECTRONIC TECHNOLOGIES, LLC AND SHOULD NOT BE USED WITHOUT WRITTEN PERMISSION

| | | | | | | | |
|----------------------|----------|---|------------|----------|--------------------------------|----------|---------|
| REVISION DESCRIPTION | REVISED | PRODUCT SPECIFICATION FOR PICOBLADE 1.25 W/B TH RA TYPE GOLD PLATING CONNECTOR | | | | | |
| CHANGE NO. | 702978 | | | | | | |
| REVISED BY | QHE31 | DATE | 2022/03/11 | DOC TYPE | DOC TYPE DESCRIPTION | DOC PART | SERIES |
| REV APPR BY | SAKIYAMA | DATE | 2022/05/12 | PS | ENGINEERING SPECIFICATION WORD | 000 | 51021 |
| INITIAL RELEASE | | | | CUSTOMER | DOCUMENT NUMBER | REVISION | SHEET |
| INITIAL DRWN | SOBARA01 | DATE | 2017/10/12 | GENERAL | 51021000-PS | F | 8 OF 17 |
| INITIAL APPR | TKANEKO | DATE | 2018/10/30 | | | | |

| 項目 Item | | 条件 Test Condition | 規格 Requirement | |
|------------|--|---|-----------------------|--|
| 4-3-12 | はんだ付け性 Solderability | <p>ターミナルまたはピンを本体取付け基準面より0.8mm迄、245±3°Cのはんだに3±0.5秒浸す。</p> <p>Dip terminal or pin into immerse the area up to 1.2mm from the bottom of the housing into solder molten at 245±3°C for 3±0.5 sec.</p> | 濡れ性 Solder Wetting | <p>ピンホールや隙間なく浸漬面積の95%以上</p> <p>95% of immersed area must show no voids, pin holes.</p> |
| 4-3-13 | はんだ耐熱性 Resistance to Soldering Heat | <p><u>ディップの場合</u> <u>Soldering bath method</u></p> <p>ターミナルまたはピンを本体取付け基準面より0.8mm迄、260±5°Cのはんだに10±0.5秒浸す。</p> <p>Dip terminal or pin into immerse the area up to 0.8mm from the bottom of the housing into solder molten at 260±5°C for 10±0.5 sec.</p> | 外観 Appearance | <p>端子ガタ、割れ等製品機能を損なう異常なきこと</p> <p>No Damage on function</p> |
| | | <p><u>手はんだ時</u> <u>(Reflow by Manual Soldering iron)</u></p> <p>370~400°Cのはんだゴテにて最大5秒加熱する。但し、端ピンに異常な加圧のないこと。</p> <p>Using a soldering iron (370~400°C for 5 seconds MAX) heat up. However, do not apply excessive pressure to either the terminals.</p> | | |

(): 参考規格 Reference Standard
 { }: 参考単位 Reference Unit

【5. 外観形状、寸法及び材質 PRODUCT SHAPE, DIMENSIONS AND MATERIALS】

5-1. 製品寸法及び材質 Dimensions and materials of product.

図面参照 Refer to the drawing.

THIS DOCUMENT CONTAINS INFORMATION THAT IS PROPRIETARY TO MOLEX ELECTRONIC TECHNOLOGIES, LLC AND SHOULD NOT BE USED WITHOUT WRITTEN PERMISSION

| | | | | | | | |
|----------------------|----------|---|------------|----------|--------------------------------|----------|---------|
| REVISION DESCRIPTION | REVISED | PRODUCT SPECIFICATION FOR PICOBLADE 1.25 W/B TH RA TYPE GOLD PLATING CONNECTOR | | | | | |
| CHANGE NO. | 702978 | | | | | | |
| REVISED BY | QHE31 | DATE | 2022/03/11 | DOC TYPE | DOC TYPE DESCRIPTION | DOC PART | SERIES |
| REV APPR BY | SAKIYAMA | DATE | 2022/05/12 | PS | ENGINEERING SPECIFICATION WORD | 000 | 51021 |
| INITIAL RELEASE | | | | CUSTOMER | DOCUMENT NUMBER | REVISION | SHEET |
| INITIAL DRWN | SOBARA01 | DATE | 2017/10/12 | GENERAL | 51021000-PS | F | 9 OF 17 |
| INITIAL APPR | TKANEKO | DATE | 2018/10/30 | | | | |

【6. 挿入力及び抜去力 INSERTION / WITHDRAWAL FORCE】

| 極数 No of CKT | 単位 Unit | 挿入力（最大値） Insertion force (MAX) | | | 抜去力（最小値） Withdrawal force (MIN) | | |
|--------------------|--------------|-----------------------------------|-----------------|-----------------|------------------------------------|-----------------|-----------------|
| | | 初回 1st | 6回目 6th | 30回目 30th | 初回 1st | 6回目 6th | 30回目 30th |
| 2 | N { kgf } | 19.6 { 2.0 } | 17.6 { 1.8 } | 15.6 { 1.6 } | 2.8 { 0.28 } | 2.3 { 0.23 } | 1.8 { 0.18 } |
| 3 | N { kgf } | 24.5 { 2.5 } | 22.5 { 2.3 } | 20.5 { 2.1 } | 3.0 { 0.30 } | 2.5 { 0.25 } | 2.0 { 0.20 } |
| 4 | N { kgf } | 29.4 { 3.0 } | 27.4 { 2.8 } | 25.4 { 2.6 } | 3.3 { 0.33 } | 2.8 { 0.28 } | 2.3 { 0.23 } |
| 5 | N { kgf } | 34.3 { 3.5 } | 32.3 { 3.3 } | 30.3 { 3.1 } | 3.8 { 0.38 } | 3.3 { 0.33 } | 2.8 { 0.28 } |
| 6 | N { kgf } | 39.2 { 4.0 } | 37.2 { 3.8 } | 35.2 { 3.6 } | 4.3 { 0.43 } | 3.8 { 0.38 } | 3.3 { 0.33 } |
| 7 | N { kgf } | 44.1 { 4.5 } | 42.1 { 4.3 } | 40.1 { 4.1 } | 4.7 { 0.48 } | 4.3 { 0.43 } | 3.8 { 0.38 } |
| 8 | N { kgf } | 49.0 { 5.0 } | 47.0 { 4.8 } | 45.0 { 4.6 } | 5.2 { 0.53 } | 4.7 { 0.48 } | 4.3 { 0.43 } |
| 9 | N { kgf } | 53.9 { 5.5 } | 51.9 { 5.3 } | 49.9 { 5.1 } | 5.5 { 0.56 } | 5.0 { 0.51 } | 4.5 { 0.46 } |
| 10 | N { kgf } | 58.8 { 6.0 } | 56.8 { 5.8 } | 54.8 { 5.6 } | 5.8 { 0.59 } | 5.3 { 0.54 } | 4.8 { 0.49 } |
| 11 | N { kgf } | 63.7 { 6.5 } | 61.7 { 6.3 } | 59.7 { 6.1 } | 6.1 { 0.62 } | 5.6 { 0.57 } | 5.1 { 0.52 } |
| 12 | N { kgf } | 68.6 { 7.0 } | 66.6 { 6.8 } | 64.6 { 6.6 } | 6.4 { 0.65 } | 5.9 { 0.60 } | 5.4 { 0.55 } |
| 13 | N { kgf } | 73.5 { 7.5 } | 71.5 { 7.3 } | 69.5 { 7.1 } | 6.7 { 0.68 } | 6.2 { 0.63 } | 5.7 { 0.58 } |
| 14 | N { kgf } | 78.4 { 8.0 } | 76.4 { 7.8 } | 74.4 { 7.6 } | 7.0 { 0.71 } | 6.5 { 0.66 } | 6.0 { 0.61 } |
| 15 | N { kgf } | 83.3 { 8.5 } | 81.3 { 8.3 } | 79.3 { 8.1 } | 7.3 { 0.74 } | 6.8 { 0.69 } | 6.3 { 0.64 } |

THIS DOCUMENT CONTAINS INFORMATION THAT IS PROPRIETARY TO MOLEX ELECTRONIC TECHNOLOGIES, LLC AND SHOULD NOT BE USED WITHOUT WRITTEN PERMISSION

| | | | | | | | |
|----------------------|----------|---|------------|----------|--------------------------------|----------|-------------|
| REVISION DESCRIPTION | REVISED | PRODUCT SPECIFICATION FOR PICOBLADE 1.25 W/B TH RA TYPE GOLD PLATING CONNECTOR | | | | | |
| CHANGE NO. | 702978 | | | | | | |
| REVISED BY | QHE31 | DATE | 2022/03/11 | DOC TYPE | DOC TYPE DESCRIPTION | DOC PART | SERIES |
| REV APPR BY | SAKIYAMA | DATE | 2022/05/12 | PS | ENGINEERING SPECIFICATION WORD | 000 | 51021 |
| INITIAL RELEASE | | | | CUSTOMER | DOCUMENT NUMBER | REVISION | SHEET |
| INITIAL DRWN | SOBARA01 | DATE | 2017/10/12 | GENERAL | 51021000-PS | F | 10 OF 17 |
| INITIAL APPR | TKANEKO | DATE | 2018/10/30 | | | | |

【7. 圧着端子取り扱い上の注意事項 INSTRUCTION UPON USAGE OF CRIMP TERMINAL】

1. 圧着端子取り扱いについて、AS-56000-001をご参照お願いします。
Please refer to AS-56000-001 for usage of CRIMP TERMINAL.

【8. 注記 NOTES.】

- 本製品のプラスチック部に黒点、気泡等が確認される場合や色合いが異なる場合（経年変化によるハウジングの変色を含む）が御座いますが、製品性能に影響は御座いません。
There is no influence in the product performance though the black spot or bubble etc. might be confirmed to the plastic part of this product and the shade might be different (discoloration by secular distortion etc.).
- 本製品のハウジング及びめっき表面に多少の傷が確認される場合がありますが、製品性能に問題御座いません。
A few scratches may be confirmed to the surface of the housing and the plating of this product, however, there is no problem in the product performance.
- 本製品のプラスチック部が紫外線により変色する場合がありますが、製品性能には問題御座いません。
Discoloration of the plastic part of this product can result from exposure to ultraviolet light. There is no problem in the product performance.
- コネクタの性能を損なう恐れがある為、コネクタの洗浄は、行わないでください。
Please do not conduct any washing process on the connectors because it may damage the product's function.
- 本製品をご使用時に取り付けられた電線・プリント基板の共振や、機器の回転構造や可動部分の動作によりコネクタ嵌合部（接点部）が常に動いてしまう状態での御使用は避けてください。
接触部の摺動磨耗等による 接触不良の原因となります。
従って、機器内で電線・プリント基板を固定し、共振を抑える等の処置をお願い致します。
Please do not use the connectors in a condition where the wire, PWB, or the contact area is experiencing a sympathetic vibration of wires and PWB, and constant movement of devices. This may cause a defect in the contact due to the contact area being worn down. Therefore, please fix wires and PWB on the chassis, and reduces sympathetic vibration.
- コネクタ嵌合状態で基板の持ち運び等コネクタに負荷が掛かる作業は行わないようにしてください。コネクタ破損等の原因となる場合が御座います。
Please do not do work that the load hangs in the connectors like the carrying of the substrate etc. with the connectors engages. There is a case where it causes the connectors damage etc.

THIS DOCUMENT CONTAINS INFORMATION THAT IS PROPRIETARY TO MOLEX ELECTRONIC TECHNOLOGIES, LLC AND SHOULD NOT BE USED WITHOUT WRITTEN PERMISSION

| REVISION DESCRIPTION | REVISED | PRODUCT SPECIFICATION FOR PICOBLADE 1.25 W/B TH RA TYPE GOLD PLATING CONNECTOR | | | | | | |
|----------------------|----------|---|------------|----------|--------------------------------|----------|-------------|-------|
| CHANGE NO. | 702978 | | | | | | | |
| REVISED BY | QHE31 | DATE | 2022/03/11 | DOC TYPE | DOC TYPE DESCRIPTION | DOC PART | SERIES | |
| REV APPR BY | SAKIYAMA | DATE | 2022/05/12 | PS | ENGINEERING SPECIFICATION WORD | 000 | 51021 | |
| INITIAL RELEASE | | | CUSTOMER | | DOCUMENT NUMBER | | REVISION | SHEET |
| INITIAL DRWN | SOBARA01 | DATE | 2017/10/12 | GENERAL | 510210000-PS | F | 11 OF 17 | |
| INITIAL APPR | TKANEKO | DATE | 2018/10/30 | | | | | |

7. 嵌合後、コネクタピッチ方向、スパン方向及び回転方向への負荷がかかるような動作またはセッ
トはしないでください。コネクタ破壊やはんだクラックを引き起こします。
After mated the connectors, please do not allow the PWBs to apply pressure on the connectors
in either the pitch direction, the span direction or rotational direction. It may cause damage to the
connectors and may crack the soldering.
8. 本製品及び加工工程品（仕掛品）や加工品（ハーネス等）の梱包及び輸送・保管時にはコネク
タに負荷が加わらないようご注意ください。変形、破損などの原因となり、コネクタの性能不
良の原因となります。Please try to prevent any external forces or shock from being applied to
the connectors while the cable assembly is in process, when it is being packaged, or while it is in
transportation. This may cause deformation and damage to the connectors and cause a defect
in the product's performance.
9. 本製品をご使用時には、1PIN当りの定格以上の電流を複数の回路に分岐しての使用は避けて
ください。When using this product, please ensure that the specification for rated current per
circuit is followed. Do not allow the sum of the current used on several circuits to exceed the
maximum allowable current.
10. 活電状態の電気回路で、挿入、抜去ができることを前提に作られておりません。スパーク等
による危険の発生、性能不良につながりますので、活電状態での挿入、抜去はしないでくだ
さい。
This product is not designed for the mating and unmating of the connectors to be performed
under the condition of an active electrical circuit. It may cause a spark and product defect if the
connectors are mated and unmated in this way.
11. コネクタに適用できる電線は、原則として錫めっきつき付軟銅撚り線です。
その他の電線の使用については別途ご確認ください。
The applicable wire for this connectors, in principle, is tin-plated copper stranded wire. Please
consult us and evaluate it in advance when using other wires.
12. コネクタに外力が加わらないようにクリアランスをあげた筐体構造にしてください。
Please keep enough clearance between connectors and chassis of your application in order not
to apply pressure on the connectors.
13. 電線の結束はコネクタから50mm以上のところで、電線に加わる力が均一になるようにしてく
ださい。ハーネス品で電線一本（又は特定の数本）に力が加わらない様にしてください。
Please tie the cable at least 50mm away from the edge of the connectors and try to ensure that
the force is applied evenly on all of the wires.
14. 治具等を使用して圧着端子を抜いた場合には、ランスが変形し強度が低下し端子を再装着後の
端子保持力が極端に低下します。そのため、圧着端子のリペアの際には新しいハウジングを必
ず使用してください。
When extracting a crimp terminal from the housing using a jig, it may deform the housing lance
and therefore reduce the terminal retention force enormously after re-inserting of the terminal.
Therefore, please ensure to use a new housing after repairing the crimp terminals.

THIS DOCUMENT CONTAINS INFORMATION THAT IS PROPRIETARY TO MOLEX ELECTRONIC TECHNOLOGIES, LLC AND SHOULD NOT BE USED WITHOUT WRITTEN PERMISSION

| REVISION DESCRIPTION | | REVISED | | PRODUCT SPECIFICATION FOR PICOBLADE 1.25 W/B TH RA TYPE GOLD PLATING CONNECTOR | | | | | |
|----------------------|----------|---------|------------|---|--------------------------------|-----------------|----------|----------|-------------|
| CHANGE NO. | 702978 | | | | | | | | |
| REVISED BY | QHE31 | DATE | 2022/03/11 | DOC TYPE | DOC TYPE DESCRIPTION | | DOC PART | SERIES | |
| REV APPR BY | SAKIYAMA | DATE | 2022/05/12 | PS | ENGINEERING SPECIFICATION WORD | | 000 | 51021 | |
| INITIAL RELEASE | | | | CUSTOMER | | DOCUMENT NUMBER | | REVISION | SHEET |
| INITIAL DRWN | SOBARA01 | DATE | 2017/10/12 | GENERAL | | 510210000-PS | | F | 12 OF 17 |
| INITIAL APPR | TKANEKO | DATE | 2018/10/30 | | | | | | |

15. ハーネス加工品及びコネクタ嵌合後の電線の引き回しの際、引張りによる力が加わりますと、接点部、結線部（圧着部）やロック部（端子ロック部）が損傷を受け、接触不良の原因となります。
電線の引回し配線をされる場合、コネクタに無理な外力が加わらないように、電線に緩みを持たせ、余裕を持たせる処置をしてください。
The cable assembly should not have a constant stress or pulling force applied on it when it is in the mated condition. This phenomenon may damage the contact area or wiring area (crimping). Therefore, when designing the wire positioning, please ensure that there is enough length of wire to avoid stress on the connectors.
16. 電線はまとめて軽くつかみ、ゆっくり、軸方向にまっすぐに引き抜いてください。また、斜めにこじりながら抜くことは避けてください。コネクタを破損させる恐れが御座います。
Please hold wires all together lightly and withdraw slowly, axially and straightly. Please avoid withdrawing them with an angle and roughly. That might cause damage to connector.
- 17.ハウジングのロック部やランス部などの可動部、及び端子を故意に変形させないでください。製品性能が満足出来ない原因となります。
Do not deform the movable part as lock part and lance part of Plug. HS'G and terminals on purpose. It would lead to product failure.
18. はんだ実装部の未はんだは、ターミナル脱落、ピン間ショート、ターミナル座屈、またコネクタ基板からの外れが懸念されます。従って全てのターミナルテール部にはんだ付けを行ってください。
If you leave any soldering area on this product open, there may be the possibility of a missing terminal short circuiting between pins, terminal buckling or the potential for the connectors to come off of the PWB. Therefore, please solder all of the terminals on the PWB.
19. 実装機によってコネクタに負荷が加わると変形、破損する場合がありますので事前にご確認ください。
If there is accidental contact with the connectors while it is going through the reflow machine, there may be deformation or damage caused to the connectors. Please check to prevent this.
20. 基板実装前後に端子に触らないでください。
Please do not touch the terminals before or after mounted the connectors onto the PWB.
21. 基板実装後に基板を直接積み重ねない様に注意してください。
Please do not stack the PWB directly after mounted the connectors on it.
22. 実装後において手はんだコテによるリペアを行なう際は、必ず仕様書掲載の条件以内で行なってください。条件を超えて実施した場合、端子の抜け、接点ギャップの変化、モールドの変形、熔融等が原因により破損の原因になります。
Please conduct it under the condition of the specifications when repairing by hand soldering iron after mounting. In the case of practicing beyond the condition, the backlash, the change in the contact gap, the deformation of the mold and the melting, etc. may cause damage.

THIS DOCUMENT CONTAINS INFORMATION THAT IS PROPRIETARY TO MOLEX ELECTRONIC TECHNOLOGIES, LLC AND SHOULD NOT BE USED WITHOUT WRITTEN PERMISSION

| REVISION DESCRIPTION | REVISED | PRODUCT SPECIFICATION FOR PICOBLADE 1.25 W/B TH RA TYPE GOLD PLATING CONNECTOR | | | | | |
|----------------------|----------|---|------------|----------|--------------------------------|----------|----------|
| CHANGE NO. | 702978 | | | | | | |
| REVISED BY | QHE31 | DATE | 2022/03/11 | DOC TYPE | DOC TYPE DESCRIPTION | DOC PART | SERIES |
| REV APPR BY | SAKIYAMA | DATE | 2022/05/12 | PS | ENGINEERING SPECIFICATION WORD | 000 | 51021 |
| INITIAL RELEASE | | | | CUSTOMER | DOCUMENT NUMBER | REVISION | SHEET |
| INITIAL DRWN | SOBARA01 | DATE | 2017/10/12 | GENERAL | 510210000-PS | F | 13 OF 17 |
| INITIAL APPR | TKANEKO | DATE | 2018/10/30 | | | | |

23. はんだコテによる手修正を行なう際、過度のはんだやフラックスを使用しないでください。はんだ上がりやフラックス上がりにより接触、機能不良に至る場合がございます。
When conducting manual repairs using a soldering iron, please do not use more solder and flux than needed. This may cause solder wicking and flux wicking issues, and it will eventually cause a contact defect and functional issues.
24. コネクタのみで基板を支えることは避け、コネクタ以外での基板固定対策を行ってください。
Please do not use the connectors alone to provide mechanical support for the PWB. Please ensure that there is a fixed structure on the phone chassis or other component support for the PWB.
25. 弊社の推奨基板パターン寸法を変更して設計を行なう際は、致命的な不良の原因にもなりますのであらかじめご相談ください。
In the case of changing our recommended board pattern size and designing, please consult in advance because it may cause a fatal defect.
26. 本品の一般性能確認はガラスエポキシ基板にて実施していますので、フレキシブル基板等の特殊な基板へ実装してご使用の際は、別途ご相談願います。
It is necessary to consult separately when mount product on a special PWB or FPC.

THIS DOCUMENT CONTAINS INFORMATION THAT IS PROPRIETARY TO MOLEX ELECTRONIC TECHNOLOGIES, LLC AND SHOULD NOT BE USED WITHOUT WRITTEN PERMISSION

| | | | | | | | |
|----------------------|----------|------|------------|---|--------------------------------|----------|-------------|
| REVISION DESCRIPTION | REVISED | | | PRODUCT SPECIFICATION FOR PICOBLADE 1.25 W/B TH RA TYPE GOLD PLATING CONNECTOR | | | |
| CHANGE NO. | 702978 | | | | | | |
| REVISED BY | QHE31 | DATE | 2022/03/11 | DOC TYPE | DOC TYPE DESCRIPTION | DOC PART | SERIES |
| REV APPR BY | SAKIYAMA | DATE | 2022/05/12 | PS | ENGINEERING SPECIFICATION WORD | 000 | 51021 |
| INITIAL RELEASE | | | | CUSTOMER | DOCUMENT NUMBER | REVISION | SHEET |
| INITIAL DRWN | SOBARA01 | DATE | 2017/10/12 | GENERAL | 51021000-PS | F | 14 OF 17 |
| INITIAL APPR | TKANEKO | DATE | 2018/10/30 | | | | |

27. コネクタを基板に対して垂直に真っ直ぐ挿入してください。斜めにしたりコジリを加えたりしないでください。
 ※コネクタを保持するにはコンタクトに触れることの無い様に御注意ください。
 ※コネクタを基板に対して垂直に保持した状態で真っ直ぐに基板穴へソルダーテールを挿入してください。
 ※基板穴とソルダーテールがずれる方向や斜めに傾く様な力を加えないでください。
 ※無理に斜め挿入を行った場合、ピンの変形、抜けが生じ、コネクタが破損する恐れがあります
 Load the connector into the PWB straight down. Do not tilt or squeeze the connector in wrong directions.※When touching the connector, be sure not to touch the contacts.
 ※Load the solder tails straightly into the PWB.※Do not apply force in such directions that would damage the solder tails.
 ※In case you push the solder tails in such directions, the pin deformations and pin fallout would occur and damage the connector.

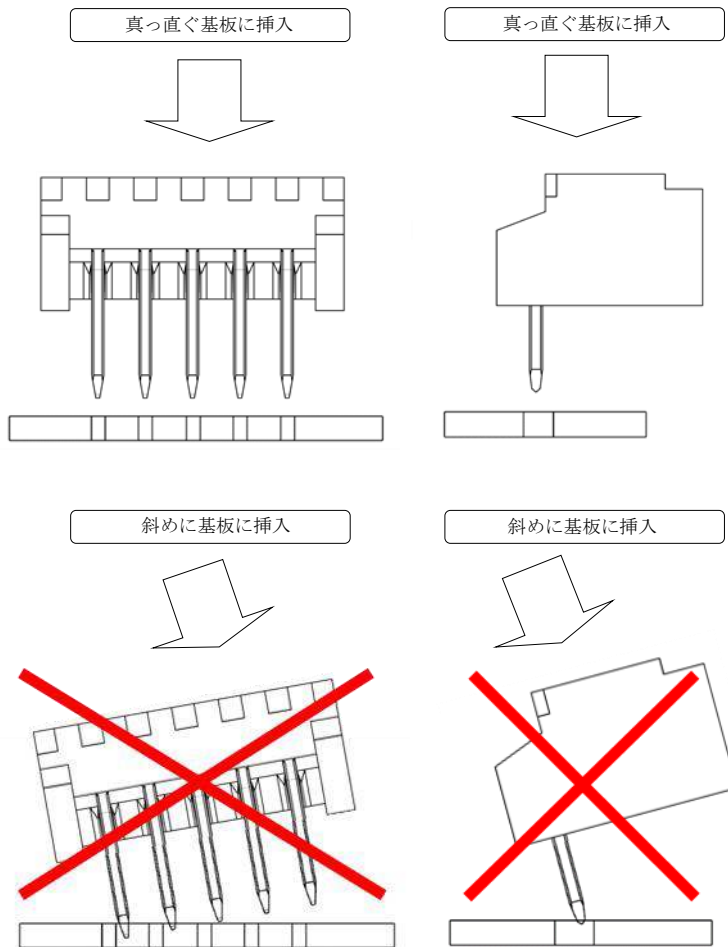

THIS DOCUMENT CONTAINS INFORMATION THAT IS PROPRIETARY TO MOLEX ELECTRONIC TECHNOLOGIES, LLC AND SHOULD NOT BE USED WITHOUT WRITTEN PERMISSION

| | | | | | | | |
|----------------------|----------|---------|------------|---|--------------------------------|----------|-------------|
| REVISION DESCRIPTION | | REVISED | | PRODUCT SPECIFICATION FOR PICOBLADE 1.25 W/B TH RA TYPE GOLD PLATING CONNECTOR | | | |
| CHANGE NO. | | 702978 | | | | | |
| REVISED BY | QHE31 | DATE | 2022/03/11 | DOC TYPE | DOC TYPE DESCRIPTION | DOC PART | SERIES |
| REV APPR BY | SAKIYAMA | DATE | 2022/05/12 | PS | ENGINEERING SPECIFICATION WORD | 000 | 51021 |
| INITIAL RELEASE | | | | CUSTOMER | DOCUMENT NUMBER | REVISION | SHEET |
| INITIAL DRWN | SOBARA01 | DATE | 2017/10/12 | GENERAL | 51021000-PS | F | 15 OF 17 |
| INITIAL APPR | TKANEKO | DATE | 2018/10/30 | | | | |

28. 嵌合は極力嵌合軸に沿って平行に行ってください。その際、リセハウジングとプラグの外壁同士を合せる様に位置決めした後に押し込み、コネクタ同士が突き当たる（完全嵌合位置）まで真っ直ぐ押し込んでください。斜めの嵌合になる場合は 10° 以下の角度でリセハウジングとプラグの外壁同士を軽く当て、位置決めした後に嵌合してください。尚、コネクタ同士を過度に傾けた状態で嵌合を行いますと、ハウジングが破壊する恐れがありますのでこのような嵌合はお避けください。
Please do the mating as much as possible to along to mating axis. At this time, positioning each side of external faces of receptacle housing and plug and push to mating until both connectors strikes each other (complete mating position). In the case of diagonal mating, touch with external faces with receptacle housing and plug under the angle of 10°lightly, and push to mating in order to avoid the connector break.

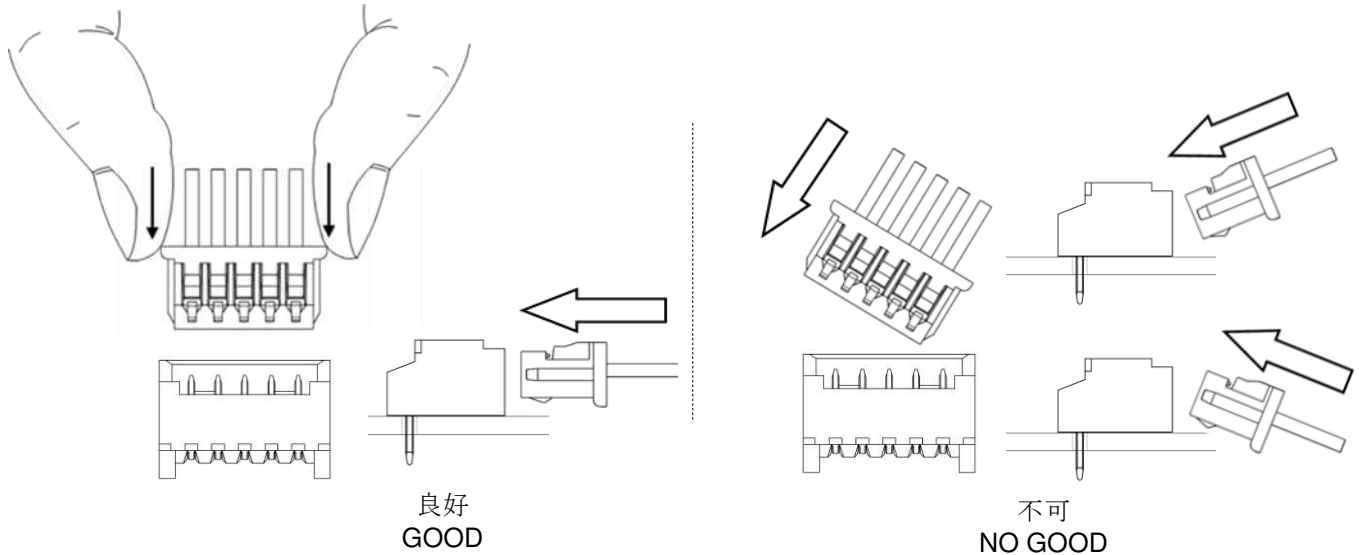

29. 本製品のハウジング材料は耐熱性ポリアミドを使用しており、ハウジングの吸水状態、或いは、はんだ付け条件によっては、リフローはんだ付け時にハウジング表面に「ふくれ」が発生する可能性があります。この「ふくれ」に関しましては、ポリアミド材の物性変化を伴うものではなく、製品機能を損なうものではありません。

The housing material of this product is made from a high heat resistant polyamide. The soldering condition and the water absorption properties of the housing material may cause blistering on the housing surface. Because this blister is not caused by property change, it does not damage the product's features.

30. 本製品のリセプタクルハウジング材料はポリアミドを使用しており、吸水状態によって挿抜力・挿入感が変わります。過度な吸水により、挿入時に嵌合相手と若干干渉する場合や、クリック感が弱くなる場合がありますが、製品性能、機能には問題ございません。

Because the receptacle housing material of this product is using polyamide, the water absorption status of the housing material might change insertion force, withdrawal force, or the feeling of insertion. Its excessive water absorption may cause to interfere with insertion a little bit or to weaken the click feeling of the lock when mating. However it does not damage the product's features and functions.

THIS DOCUMENT CONTAINS INFORMATION THAT IS PROPRIETARY TO MOLEX ELECTRONIC TECHNOLOGIES, LLC AND SHOULD NOT BE USED WITHOUT WRITTEN PERMISSION

| | | | | | | | |
|----------------------|----------|---------|------------|---|--------------------------------|----------|-------------|
| REVISION DESCRIPTION | | REVISED | | PRODUCT SPECIFICATION FOR PICOBLADE 1.25 W/B TH RA TYPE GOLD PLATING CONNECTOR | | | |
| CHANGE NO. | | 702978 | | | | | |
| REVISED BY | QHE31 | DATE | 2022/03/11 | DOC TYPE | DOC TYPE DESCRIPTION | DOC PART | SERIES |
| REV APPR BY | SAKIYAMA | DATE | 2022/05/12 | PS | ENGINEERING SPECIFICATION WORD | 000 | 51021 |
| INITIAL RELEASE | | | | CUSTOMER | DOCUMENT NUMBER | REVISION | SHEET |
| INITIAL DRWN | SOBARA01 | DATE | 2017/10/12 | GENERAL | 51021000-PS | F | 16 OF 17 |
| INITIAL APPR | TKANEKO | DATE | 2018/10/30 | | | | |

【9. 接触抵抗測定箇所 CONTACT RESISTANCE MEASURING POINT】

接触抵抗 Contact Resistance
 $m\Omega = V/A$

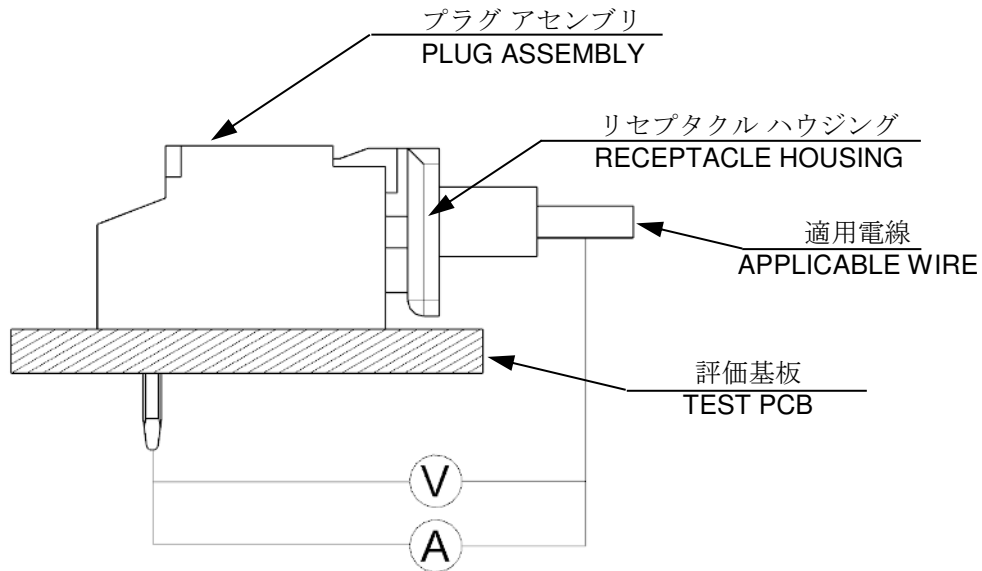

THIS DOCUMENT CONTAINS INFORMATION THAT IS PROPRIETARY TO MOLEX ELECTRONIC TECHNOLOGIES, LLC AND SHOULD NOT BE USED WITHOUT WRITTEN PERMISSION

| | | | | | | | |
|----------------------|----------|---|------------|----------|--------------------------------|----------|-------------|
| REVISION DESCRIPTION | REVISED | PRODUCT SPECIFICATION FOR PICOBLADE 1.25 W/B TH RA TYPE GOLD PLATING CONNECTOR | | | | | |
| CHANGE NO. | 702978 | | | | | | |
| REVISED BY | QHE31 | DATE | 2022/03/11 | DOC TYPE | DOC TYPE DESCRIPTION | DOC PART | SERIES |
| REV APPR BY | SAKIYAMA | DATE | 2022/05/12 | PS | ENGINEERING SPECIFICATION WORD | 000 | 51021 |
| INITIAL RELEASE | | | | CUSTOMER | DOCUMENT NUMBER | REVISION | SHEET |
| INITIAL DRWN | SOBARA01 | DATE | 2017/10/12 | GENERAL | 510210000-PS | F | 17 OF 17 |
| INITIAL APPR | TKANEKO | DATE | 2018/10/30 | | | | |