

# Power Common Mode Chokes



## ACMP-3225 Series

Request Samples



Check Inventory



3.2 x 2.5 x 2.2 mm  
RoHS/RoHS II Compliant  
MSL Level = 1

### Features

- Commercial Grade
- PPAP ready and supported
- Excellent impedance characteristics
- Rated current up to 1.0A
- Compact size

### Applications

- DC power line common mode noise suppression.
- Switch Mode Power Supplies and regulators
- Variable Frequency Drives
- AC/DC power rectifiers

### Electrical Specifications

Part Number	Impedance ( $\Omega$ ) @100MHz	DCR (m $\Omega$ )	Rated Current (A)	Rated Voltage (Vdc)	Withstand Voltage (Vdc)	Insulation Resistance (M $\Omega$ )
	Typ. $\pm 25\%$	Max	Max	Max	Max	Min
ACMP-3225-900	90	50	1.0	50	125	10
ACMP-3225-601	600	200	1.0	50	125	10
ACMP-3225-102	1000	300	0.4	50	125	10

**Rated Current is based on an Irms temperature rise of 40°C**

**Operating Temperature: -40°C to +125°C (Including self-heating)**

**Storage (in original packaging): <40°C, <60% RH**

**ACMP-3225 Series is RoHS Compliant and Pb free**

# Power Common Mode Chokes



**ACMP-3225 Series**

Request Samples



Check Inventory



3.2 x 2.5 x 2.2 mm  
RoHS/RoHS II Compliant  
MSL Level = 1

## Electrical Specifications (Cont'd)

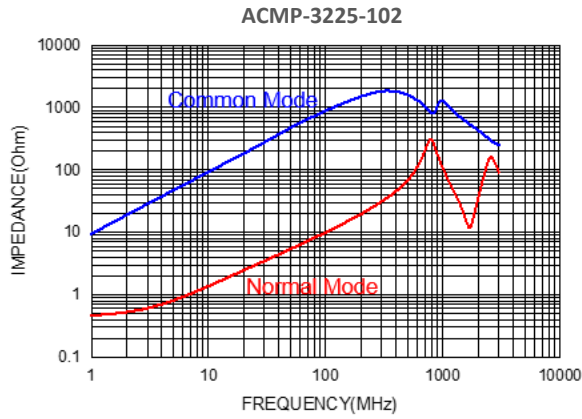
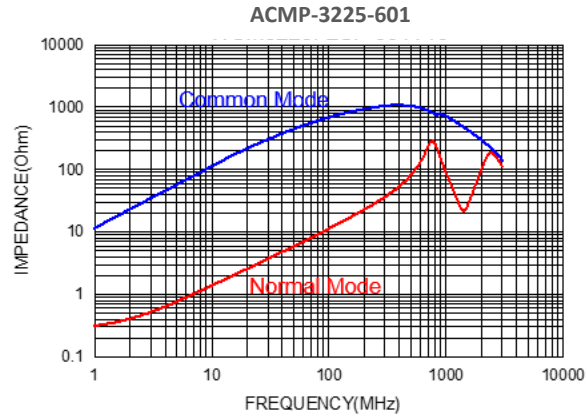
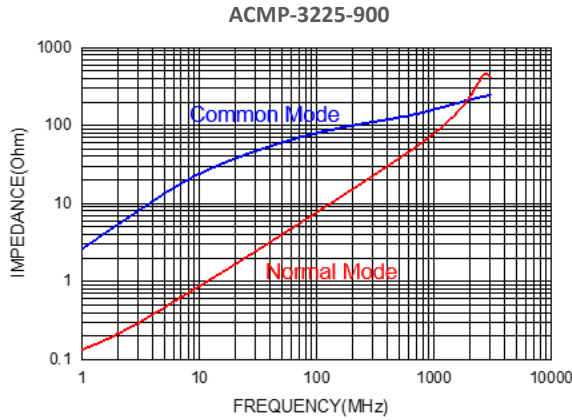

# Power Common Mode Chokes



ACMP-3225 Series

Request Samples



Check Inventory



3.2 x 2.5 x 2.2 mm  
**RoHS/RoHS II Compliant**  
 MSL Level = 1

## Mechanical Specifications

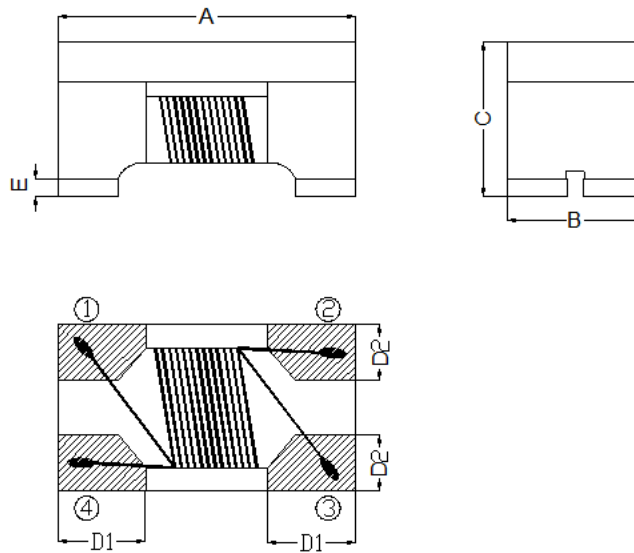

A	B	C	D1	D2	E
3.2 ± 0.2	2.5 ± 0.2	2.2 ± 0.2	0.8 ± 0.1	0.9 ± 0.1	0.15 ± 0.1

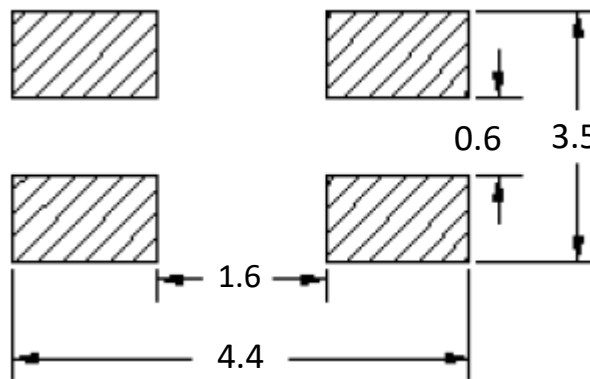

### Recommended Layout

Dimensions: mm

# Power Common Mode Chokes



**ACMP-3225 Series**

Request Samples



Check Inventory



3.2 x 2.5 x 2.2 mm  
**RoHS/RoHS II Compliant**  
 MSL Level = 1

## Schematic

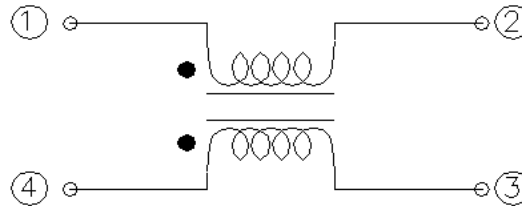

## Materials

Description	Specification
Core	Ferrite core
Wire	Enameled copper wire
Terminal	Ag/Ni/Sn

## Part Identification

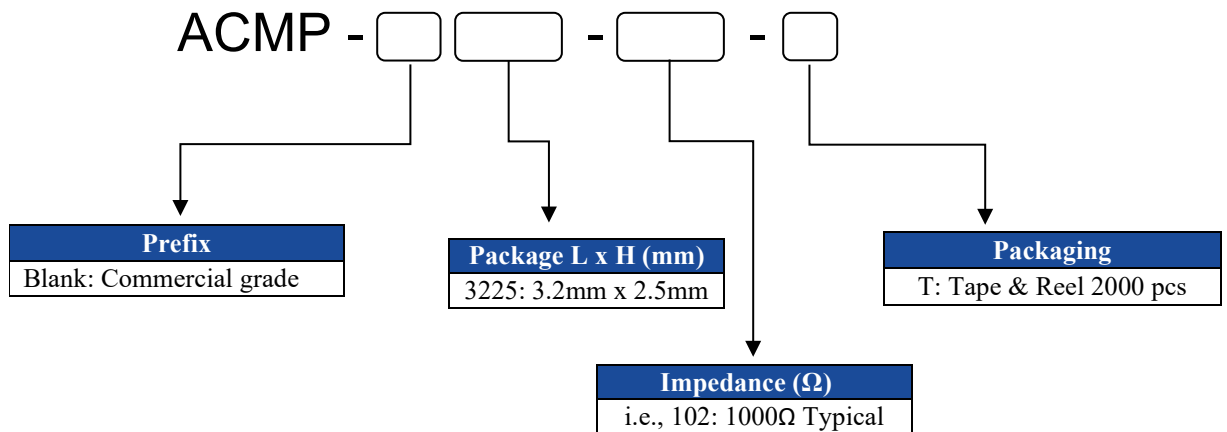

# Power Common Mode Chokes



ACMP-3225 Series

Request Samples



Check Inventory



3.2 x 2.5 x 2.2 mm  
 RoHS/RoHS II Compliant  
 MSL Level = 1

## Reflow Profile

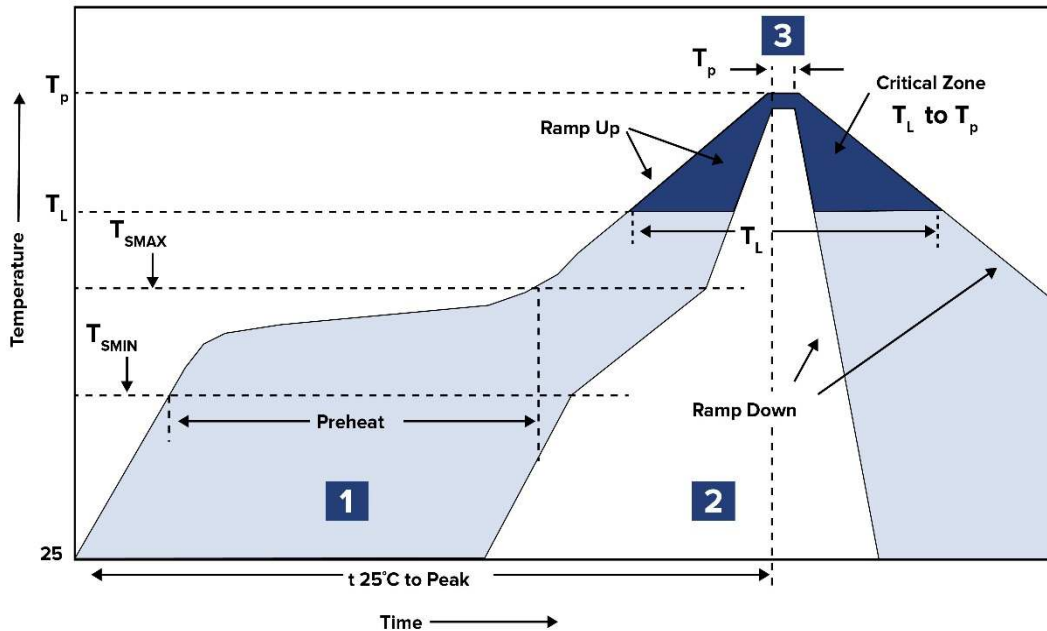

Zone	Description	Temperature	Times
1	Preheat	$T_{SMIN} \sim T_{SMAX}$ 150°C ~ 200°C	60 ~ 120 sec.
2	Reflow	$T_L$ 217°C	60 ~ 150 sec.
3	Peak heat	$T_P$ 250°C Max.	< 30 Sec.

3 °C/Sec. Max Ramp up rate

# Power Common Mode Chokes



**ACMP-3225 Series**

Request Samples



Check Inventory



**3.2 x 2.5 x 2.2 mm**  
**RoHS/RoHS II Compliant**  
**MSL Level = 1**

## Packing

**Tape & Reel: 2000pcs/reel**

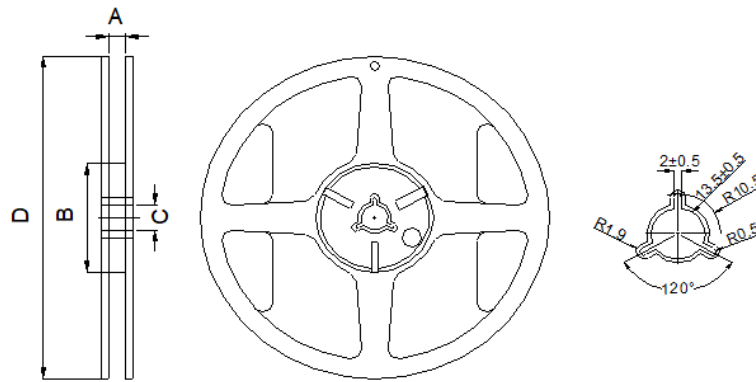

7"x8mm

A	B	C	D
9.0 ± 0.50	60.0 ± 2.0	13.5 ± 0.50	178 ± 2.0

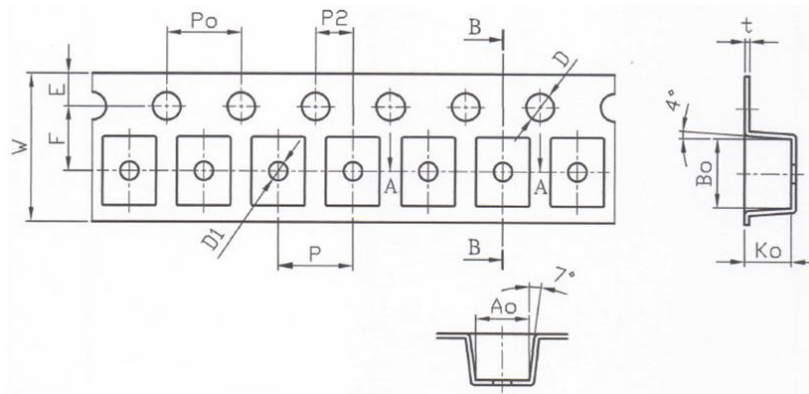

W	P	P0	P2	D	E	F	A0	B0	K0
8.0 ± 0.10	4.0 ± 0.10	4.0 ± 0.10	2.0 ± 0.10	1.5 ± 0.10	1.75 ± 0.10	3.5 ± 0.10	2.88 ± 0.10	3.72 ± 0.10	2.5 ± 0.10

**Dimensions: mm**

**ATTENTION:** Abracon LLC's products are COTS – Commercial-Off-The-Shelf products; suitable for Commercial, Industrial and, where designated, Automotive Applications. Abracon's products are not specifically designed for Military, Aviation, Aerospace, Life-dependent Medical applications or any application requiring high reliability where component failure could result in loss of life and/or property. For applications requiring high reliability and/or presenting an extreme operating environment, written consent and authorization from Abracon LLC is required. Please contact Abracon LLC for more information.



5101 Hidden Creek Ln Spicewood TX 78669  
 Phone: 512-371-6159 | Fax: 512-351-8858  
 For terms and conditions of sales, please visit:  
[www.abracon.com](http://www.abracon.com)

**REVISION: IR 06-29-22**

ABRACON IS  
 ISO9001-2015  
 CERTIFIED