

THIS DRAWING IS UNPUBLISHED. RELEASED FOR PUBLICATION  
 © COPYRIGHT - By - ALL RIGHTS RESERVED.

LOC	DIST	REVISIONS			
P	LTR	DESCRIPTION	DATE	DWN	APVD
G	14	G1	REVISED PER ECO-11-004820	11MAR11	RK HMR

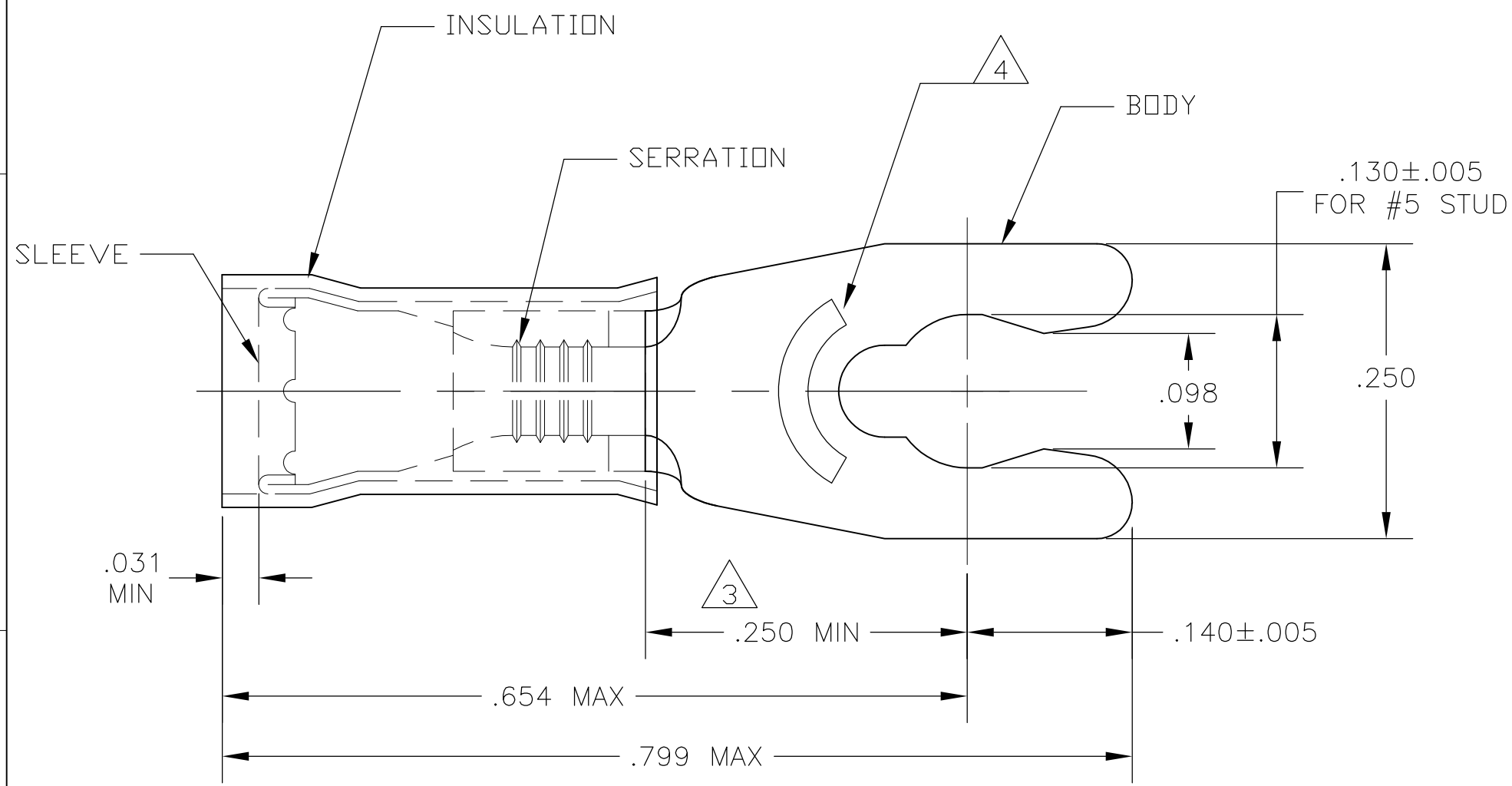

- 1 FOR .080-.125 WIRE INSULATION DIA
- 2 TONGUE MATERIAL THK = .031±.002
- 3 APPLIES FROM THE METAL EDGE OF THE BARREL TO THE CENTER OF THE STUD
- 4 MARKING 22-18 FOR MILITARY, COMMERCIAL RANGE 22-16

QTY	DESCRIPTION	MATERIAL & FINISH	PART NO
100	LOOSE PIECE, BOX	BODY: PHOS BRONZE PER ASTM-B103 TIN PLATE PER ASTM-B545	8-52928-1
5,000	52928 ON TAPE	SLEEVE: COPPER PER ASTM-B152	52928-1
1	WIRE TERMINAL	INSULATION: NYLON PER ASTM-D4066 TYPE 1, COLOR: RED	52928

THIS DRAWING IS A CONTROLLED DOCUMENT.		DWN jr_ruth 09MAR10	<b>STE</b> TE Connectivity	
DIMENSIONS: INCHES		CHK TOM MICHIELUTTI 09MAR10		
TOLERANCES UNLESS OTHERWISE SPECIFIED:		APVD TOM MICHIELUTTI 09MAR10	NAME WIRE TERMINAL, PIDG, SPRING SPADE WIRE SIZE: 22-16	
0 PLC ± - 1 PLC ± - 2 PLC ± .008 3 PLC ± - 4 PLC ± - ANGLES ± 5°		PRODUCT SPEC -	RESTRICTED TO -	
MATERIAL SEE TABLE		FINISH SEE TABLE	APPLICATION SPEC -	SIZE A3
		WEIGHT -	CAGE CODE 00779	DRAWING NO C-52928
CUSTOMER DRAWING			SCALE 8:1	SHEET 1 OF 1
			REV G1	