

200 mA 42 V Ultra Low Supply Current Voltage Regulator for Automotive Applications

No. EC-520-200422

OVERVIEW

The R1525x is a low supply current voltage regulator featuring 200mA output current and up to 42 V input voltage. By providing excellent noise immunity to externally generated RF noise, this device is suitable for the automotive power source for car accessories and control unit used under the electromagnetic environment.

KEY BENEFITS

- Achieves low-supply current of 2.2 μ A (Typ.) with the LDO at maximum rating 50 V (Peak Inrush Voltage: 60 V).
- Ensures the design margin by the output voltage with high-accuracy of $\pm 0.6\%$ ($T_a = 25^\circ\text{C}$).
- Protects the output voltage variations in high-frequency noise band (10MHz to 1GHz).

KEY SPECIFICATIONS

- Input Voltage Range: 3.5 V to 42.0 V
- Maximum Rating: 50 V
(Peak Inrush Voltage: 60 V@200ms or less)
- Operating Temperature Range: -40°C to 125°C
- Supply Current: Typ. 2.2 μ A (Typ. 0.1 μ A at Standby)
- Dropout Voltage: Typ. 0.6 V ($I_{OUT} = 200$ mA, $V_{OUT} = 5.0$ V)
- Output Voltage Range: 1.8 V, 2.5 V, 2.8 V, 3.0 V, 3.3 V, 3.4 V, 5.0 V, 5.5 V, 6.0 V, 6.4 V, 7.5 V, 8.0 V, 8.5 V, 9.0 V, 10.0 V, 10.5V, 11.0 V, 12.0 V
- Output Voltage Accuracy: $\pm 0.6\%$ ($T_a = 25^\circ\text{C}$)
 $\pm 1.6\%$ ($-40^\circ\text{C} \leq T_a \leq 125^\circ\text{C}$)
- Input Stability: Typ. 0.01%/V ($V_{SET} + 1$ V $\leq V_{IN} \leq 42$ V)
- Short-circuit Protection: Limited to Typ. 80 mA
- Overcurrent Protection: Limited to Typ. 350 mA
- Thermal Shutdown: Detected at Typ. 160°C

CHARACTERISTICS

Noise Immunity Characteristic

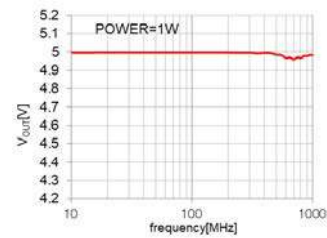

TYPICAL APPLICATIONS

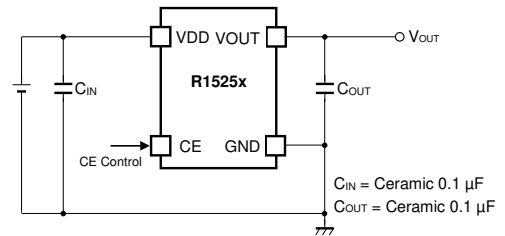

PACKAGES (unit: mm)



SOT-23-5
2.9 x 2.8 x 1.1

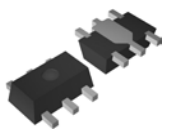

SOT-89-5
4.5 x 4.35 x 1.5



HSOP-6J
5.02 x 6.0 x 1.5

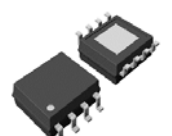

HSOP-8E
5.2 x 6.2 x 1.45

APPLICATIONS

- Power source for accessories such as car audios, car navigation systems, and ETC systems
- Power source for ECUs such as EV inverter and battery charge control unit

R1525x

No. EC-520-200422

SELECTION GUIDE

The set output voltage, the package type, and the quality class are user-selectable.

Selection Guide

Product Name	Package	Quantity per Reel	Pb Free	Halogen Free
R1525NxxxB-TR-#E	SOT-23-5	3,000 pcs	Yes	Yes
R1525HxxxB-T1-#E	SOT-89-5	1,000 pcs	Yes	Yes
R1525SxxxB-E2-#E	HSOP-6J	1,000 pcs	Yes	Yes
R1525SxxxH-E2-#E	HSOP-8E	1,000 pcs	Yes	Yes

xxx : Specify the set output voltage (V_{SET})

1.8 V (018) / 2.5 V (025) / 2.8 V (028) / 3.0 V (030) / 3.3 V (033) / 3.4 V (034) / 5.0 V (050) /
5.5 V (055) / 6.0 V (060) / 6.4 V (064) / 7.5 V (075) / 8.0 V (080) / 8.5 V (085) / 9.0 V (090)
10.0 V (100) / 10.5V (105) / 11.0 V (110) / 12.0 V (120)

: Quality Class

#	Operating Temperature Range	Test Temperature
A	-40°C to 125°C	25°C, High
K	-40°C to 125°C	Low, 25°C, High

BLOCK DIAGRAM

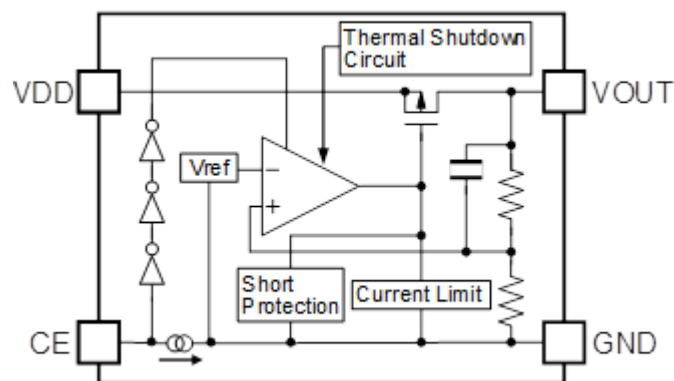

R1525x Block Diagram

PIN DESCRIPTIONS

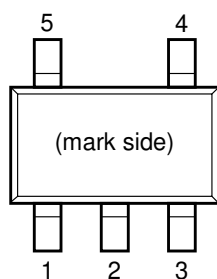

R1525N (SOT-23-5) Pin Configuration

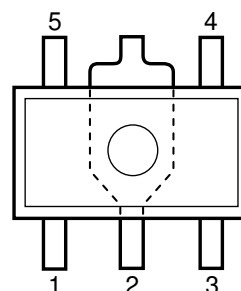

R1525H (SOT-89-5) Pin Configuration

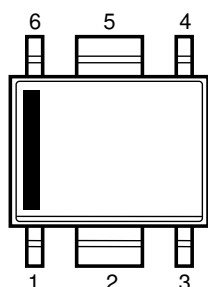

R1525S (HSOP-6J) Pin Configuration

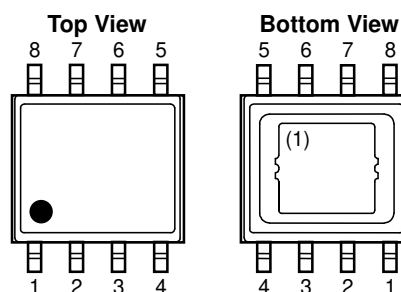

R1525S (HSOP-8E) Pin Configuration

R1525N Pin Description

Pin No.	Pin Name	Description
1	GND ⁽²⁾	Ground Pin
2	GND ⁽²⁾	Ground Pin
3	CE	Chip Enable Pin (Active-high)
4	VOUT	Output Pin
5	VDD	Input Pin

R1525H Pin Description

Pin No.	Pin Name	Description
1	VOUT	Output Pin
2	GND ⁽²⁾	Ground Pin
3	CE	Chip Enable Pin (Active-high)
4	GND ⁽²⁾	Ground Pin
5	VDD	Input Pin

⁽¹⁾ The tab on the bottom of the package enhances thermal performance and is electrically connected to GND (substrate level). It is recommended that the tab be connected to the ground plane on the board, or otherwise be left open.

⁽²⁾ The GND pin must be wired together when it is mounted on board.

R1525x

No. EC-520-200422

R1525S (HSOP-6J) Pin Description

Pin No.	Pin Name	Description
1	VOUT	Output Pin
2	GND ⁽¹⁾	Ground Pin
3	CE	Chip Enable Pin (Active-high)
4	GND ⁽¹⁾	Ground Pin
5	GND ⁽¹⁾	Ground Pin
6	VDD	Input Pin

R1525S (HSOP-8E) Pin Description

Pin No.	Pin Name	Description
1	VOUT	Output Pin
2	NC	No Connection
3	NC	No Connection
4	CE	Chip Enable Pin (Active-high)
5	GND	Ground Pin
6	NC	No Connection
7	NC	No Connection
8	VDD	Input Pin

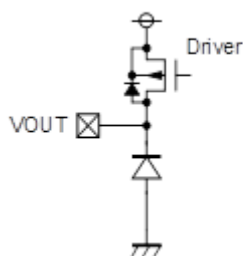
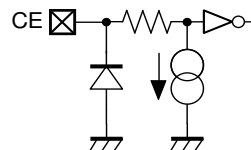
Pin Equivalent Circuit Diagrams**VOUT Pin Equivalent Circuit Diagram****CE Pin Equivalent Circuit Diagram**

⁽¹⁾ The GND pins are connected to each other on the board.

ABSOLUTE MAXIMUM RATINGS

Absolute Maximum Ratings

Symbol	Parameter	Rating	Unit	
V_{IN}	Input Voltage	-0.3 to 50	V	
V_{IN}	Peak Inrush Voltage ⁽¹⁾	60	V	
V_{CE}	CE Pin Input Voltage	-0.3 to 50	V	
V_{OUT}	Output Voltage	-0.3 to $V_{IN} + 0.3 \leq 50$	V	
I_{OUT}	Output Current	300	mA	
P_D	Power Dissipation ⁽²⁾ (JEDEC STD. 51-7)	SOT-23-5	830	mW
		SOT-89-5	3200	
		HSOP-6J	3400	
		HSOP-8E	3600	
T_j	Junction Temperature	-40 to 150	°C	
T_{stg}	Storage Temperature Range	-55 to 150	°C	

ABSOLUTE MAXIMUM RATINGS

Electronic and mechanical stress momentarily exceeded absolute maximum ratings may cause permanent damage and may degrade the life time and safety for both device and system using the device in the field. The functional operation at or over these absolute maximum ratings is not assured.

RECOMMENDED OPERATING CONDITIONS

Recommended Operating Conditions

Symbol	Parameter	Rating	Unit
V_{IN}	Input Voltage	3.5 to 42	V
T_a	Operating Temperature Range	-40 to 125	°C

RECOMMENDED OPERATING CONDITONS

All of electronic equipment should be designed that the mounted semiconductor devices operate within the recommended operating conditions. The semiconductor devices cannot operate normally over the recommended operating conditions, even if they are used over such conditions by momentary electronic noise or surge. And the semiconductor devices may receive serious damage when they continue to operate over the recommended operating conditions.

⁽¹⁾ Duration: 200 ms or less

⁽²⁾ Refer to *POWER DISSIPATION* for detailed information.

R1525x

No. EC-520-200422

ELECTRICAL CHARACTERISTICS

$C_{IN} = C_{OUT} = 0.1 \mu\text{F}$, unless otherwise noted.

The specifications surrounded by are guaranteed by design engineering at $-40^\circ\text{C} \leq T_a \leq 125^\circ\text{C}$.

R1525x (-AE) Electrical Characteristics

($T_a = 25^\circ\text{C}$)

Symbol	Parameter	Conditions		Min.	Typ.	Max.	Unit
I_{SS}	Supply Current	$V_{IN} = 14 \text{ V}$ $I_{OUT} = 0 \text{ mA}$	$V_{SET} \leq 5.0 \text{ V}$		2.2	6.5	μA
			$5.0 \text{ V} < V_{SET}$		2.5	6.8	
$I_{standby}$	Supply Current	$V_{IN} = 42 \text{ V}, V_{CE} = 0 \text{ V}$			0.1	1.0	μA
V_{OUT}	Output Voltage	$V_{SET} + 1 \text{ V}^{(1)} \leq V_{IN} \leq 42 \text{ V}, I_{OUT} = 1 \text{ mA}$	$T_a = 25^\circ\text{C}$	$\times 0.994$		$\times 1.006$	V
			$-40^\circ\text{C} \leq T_a \leq 125^\circ\text{C}$	×0.984		×1.016	
$\frac{\Delta V_{OUT}}{\Delta I_{OUT}}$	Load Regulation	$V_{IN} = V_{SET} + 3.0 \text{ V}$ $1 \text{ mA} \leq I_{OUT} \leq 200 \text{ mA}$		Refer to Product-specific Electrical Characteristics			
$\frac{\Delta V_{OUT}}{\Delta V_{IN}}$	Line Regulation	$V_{SET} + 1 \text{ V}^{(1)} \leq V_{IN} \leq 42 \text{ V}, I_{OUT} = 1 \text{ mA}$	$V_{SET} < 3.3 \text{ V}$	-20	5	20	mV
			$3.3 \text{ V} \leq V_{SET}$	-0.02	0.01	0.02	%/V
V_{DIF}	Dropout Voltage	$I_{OUT} = 200 \text{ mA}$		Refer to Product-specific Electrical Characteristics			
I_{LIM}	Output Current Limit	$V_{IN} = V_{SET} + 3.0 \text{ V}$		220	350	420	mA
I_{SC}	Short-circuit Current	$V_{IN} = 3.5 \text{ V}, V_{OUT} = 0 \text{ V}$		60	80	110	mA
V_{CEH}	CE Pin Input Voltage, high	$V_{IN} = V_{SET} + 1 \text{ V}^{(1)}$		2.0		42	V
V_{CEL}	CE Pin Input Voltage, low	$V_{IN} = 42 \text{ V}$		0		1.0	V
I_{PD}	CE Pull-down Current	$V_{IN} = 42 \text{ V}, V_{CE} = 2 \text{ V}$			0.2	0.6	μA
T_{TSD}	Thermal Shutdown Detection Temperature	Junction Temperature			160		$^\circ\text{C}$
T_{TSR}	Thermal Shutdown Release Temperature	Junction Temperature			135		$^\circ\text{C}$

All parameters are tested under the pulse load condition ($T_j \approx T_a = 25^\circ\text{C}$).

⁽¹⁾ $V_{SET} \leq 2.5 \text{ V}, V_{IN} = 3.5 \text{ V}$

The specifications surrounded by \square are guaranteed by design engineering at $-40^{\circ}\text{C} \leq T_a \leq 125^{\circ}\text{C}$.

R1525x (-AE) Product-specific Electrical Characteristics

(Ta = 25°C)

Product Name	V _{OUT} (V) (Ta = 25°C)			V _{OUT} (V) (-40°C ≤ Ta ≤ 125°C)			ΔV _{OUT} /ΔI _{OUT} (mV)			V _{DIF} (V)	
	MIN.	TYP.	MAX.	MIN.	TYP.	MAX.	MIN.	TYP.	MAX.	TYP.	MAX.
R1525x018x	1.7892	1.80	1.8108	\square 1.7712	1.80	\square 1.8288	\square -10	10	\square 40	1.6	\square 2.5
R1525x025x	2.4850	2.50	2.5150	\square 2.4600	2.50	\square 2.5400				1.2	\square 2.2
R1525x028x	2.7832	2.80	2.8168	\square 2.7552	2.80	\square 2.8448					
R1525x030x	2.9820	3.00	3.0180	\square 2.9520	3.00	\square 3.0480					
R1525x033x	3.2802	3.30	3.3198	\square 3.2472	3.30	\square 3.3528				0.8	\square 2.0
R1525x034x	3.3796	3.40	3.4204	\square 3.3456	3.40	\square 3.4544					
R1525x050x	4.9700	5.00	5.0300	\square 4.9200	5.00	\square 5.0800	\square -18	18	\square 72	0.6	\square 1.2
R1525x055x	5.4670	5.50	5.5330	\square 5.4120	5.50	\square 5.5880					
R1525x060x	5.9640	6.00	6.0360	\square 5.9040	6.00	\square 6.0960					
R1525x064x	6.3616	6.40	6.4384	\square 6.2976	6.40	\square 6.5024					
R1525x075x	7.4550	7.50	7.5450	\square 7.3800	7.50	\square 7.6200					
R1525x080x	7.9520	8.00	8.0480	\square 7.8720	8.00	\square 8.1280				0.5	\square 1.2
R1525x085x	8.4490	8.50	8.5510	\square 8.3640	8.50	\square 8.6360					
R1525x090x	8.9460	9.00	9.0540	\square 8.8560	9.00	\square 9.1440					
R1525x100x	9.9400	10.0	10.0600	\square 9.8400	10.0	\square 10.1600					
R1525x105x	10.4370	10.5	10.5630	\square 10.3320	10.5	\square 10.6680					
R1525x110x	10.9340	11.0	11.0660	\square 10.8240	11.0	\square 11.1760					
R1525x120x	11.9280	12.0	12.0720	\square 11.8080	12.0	\square 12.1920					

R1525x

No. EC-520-200422

$C_{IN} = C_{OUT} = 0.1 \mu\text{F}$, unless otherwise noted.

R1525x (-KE) Electrical Characteristics

($-40^{\circ}\text{C} \leq T_a \leq 125^{\circ}\text{C}$)

Symbol	Parameter	Conditions		Min.	Typ.	Max.	Unit
I_{SS}	Supply Current	$V_{IN} = 14 \text{ V}$	$V_{SET} \leq 5.0 \text{ V}$		2.2	6.5	μA
		$I_{OUT} = 0 \text{ mA}$	$5.0 \text{ V} < V_{SET}$		2.5	6.8	
$I_{standby}$	Supply Current	$V_{IN} = 42 \text{ V}, V_{CE} = 0 \text{ V}$			0.1	1.0	μA
V_{OUT}	Output Voltage	$V_{SET} + 1 \text{ V}^{(1)} \leq V_{IN} \leq 42 \text{ V}, I_{OUT} = 1 \text{ mA}$	$T_a = 25^{\circ}\text{C}$	$\times 0.994$		$\times 1.006$	V
			$-40^{\circ}\text{C} \leq T_a \leq 125^{\circ}\text{C}$	$\times 0.984$		$\times 1.016$	
$\frac{\Delta V_{OUT}}{\Delta I_{OUT}}$	Load Regulation	$V_{IN} = V_{SET} + 3.0 \text{ V}$ $1 \text{ mA} \leq I_{OUT} \leq 200 \text{ mA}$		Refer to Product-specific Electrical Characteristics			
$\frac{\Delta V_{OUT}}{\Delta V_{IN}}$	Line Regulation	$V_{SET} + 1 \text{ V}^{(1)} \leq V_{IN} \leq 42 \text{ V}, I_{OUT} = 1 \text{ mA}$	$V_{SET} < 3.3 \text{ V}$	-20	5	20	mV
			$3.3 \text{ V} \leq V_{SET}$	-0.02	0.01	0.02	%/V
V_{DIF}	Dropout Voltage	$I_{OUT} = 200 \text{ mA}$		Refer to Product-specific Electrical Characteristics			
I_{LIM}	Output Current Limit	$V_{IN} = V_{SET} + 3.0 \text{ V}$		220	350	420	mA
I_{SC}	Short-circuit Current	$V_{IN} = 3.5 \text{ V}, V_{OUT} = 0 \text{ V}$		60	80	110	mA
V_{CEH}	CE Pin Input Voltage, high	$V_{IN} = V_{SET} + 1 \text{ V}^{(1)}$		2.0		42	V
V_{CEL}	CE Pin Input Voltage, low	$V_{IN} = 42 \text{ V}$		0		1.0	V
I_{PD}	CE Pull-down Current	$V_{IN} = 42 \text{ V}, V_{CE} = 2 \text{ V}$			0.2	0.6	μA
T_{TSD}	Thermal Shutdown Detection Temperature	Junction Temperature		150	160		$^{\circ}\text{C}$
T_{TSR}	Thermal Shutdown Release Temperature	Junction Temperature		125	135		$^{\circ}\text{C}$

⁽¹⁾ $V_{SET} \leq 2.5 \text{ V}, V_{IN} = 3.5 \text{ V}$

R1525x (-KE) Product-specific Electrical Characteristics

(-40°C ≤ Ta ≤ 125°C)

Product Name	V _{OUT} (V) (Ta = 25°C)			V _{OUT} (V) (-40°C ≤ Ta ≤ 125°C)			ΔV _{OUT} /ΔI _{OUT} (mV)			V _{DIF} (V)				
	MIN.	TYP.	MAX.	MIN.	TYP.	MAX.	MIN.	TYP.	MAX.	TYP.	MAX.			
R1525x018x	1.7892	1.80	1.8108	1.7712	1.80	1.8288	-10	10	40	1.6	2.5			
R1525x025x	2.4850	2.50	2.5150	2.4600	2.50	2.5400				-18	18	72	0.6	1.2
R1525x028x	2.7832	2.80	2.8168	2.7552	2.80	2.8448								
R1525x030x	2.9820	3.00	3.0180	2.9520	3.00	3.0480								
R1525x033x	3.2802	3.30	3.3198	3.2472	3.30	3.3528								
R1525x034x	3.3796	3.40	3.4204	3.3456	3.40	3.4544								
R1525x050x	4.9700	5.00	5.0300	4.9200	5.00	5.0800								
R1525x055x	5.4670	5.50	5.5330	5.4120	5.50	5.5880	-18	18	72	0.5	1.2			
R1525x060x	5.9640	6.00	6.0360	5.9040	6.00	6.0960								
R1525x064x	6.3616	6.40	6.4384	6.2976	6.40	6.5024								
R1525x075x	7.4550	7.50	7.5450	7.3800	7.50	7.6200								
R1525x080x	7.9520	8.00	8.0480	7.8720	8.00	8.1280								
R1525x085x	8.4490	8.50	8.5510	8.3640	8.50	8.6360								
R1525x090x	8.9460	9.00	9.0540	8.8560	9.00	9.1440								
R1525x100x	9.9400	10.0	10.0600	9.8400	10.0	10.1600								
R1525x105x	10.4370	10.5	10.5630	10.3320	10.5	10.6680								
R1525x110x	10.9340	11.0	11.0660	10.8240	11.0	11.1760								
R1525x120x	11.9280	12.0	12.0720	11.8080	12.0	12.1920								

R1525x

No. EC-520-200422

THEORY OF OPERATION

Thermal Shutdown

When the junction temperature of this device exceeds 160°C (Typ.), the built-in thermal shutdown circuit stops the regulator operation. After that, when the temperature drops to 135°C (Typ.) or lower, the regulator restarts the operation. Unless eliminating the overheating problem, the regulator turns on and off repeatedly and a pulse shaped output voltage occurs as result.

APPLICATION INFORMATION

Typical Applications

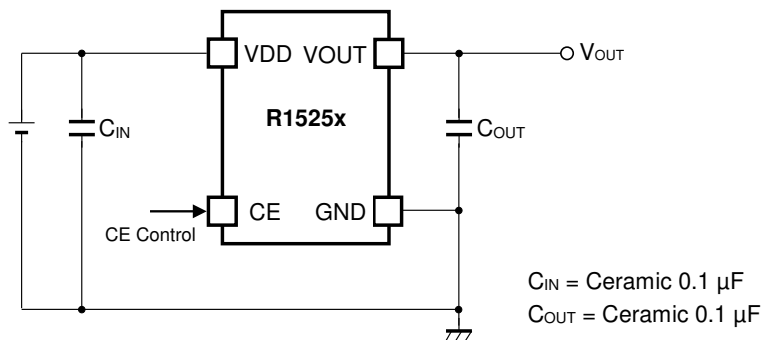

R1525x Typical Applications

Typical Application for IC Chip Breakdown Prevention

When a sudden surge of electrical current travels along the VOUT pin and GND due to a short-circuit, electrical resonance of a circuit involving an output capacitor and a short circuit inductor generates a negative voltage and may damage the device or the load devices. Connecting a schottky diode (D1) between the VOUT pin and GND has the effect of preventing damage to them.

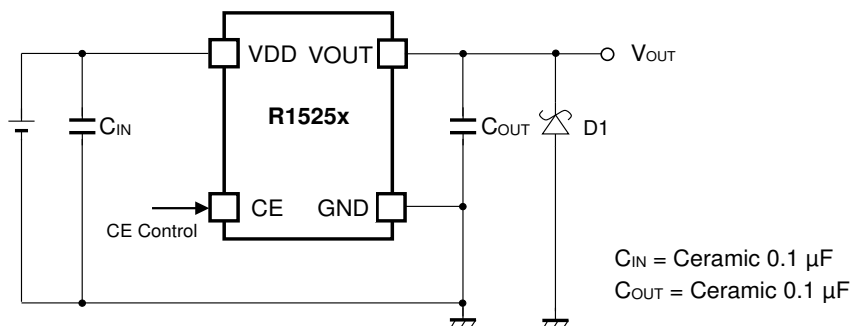

R1525x Typical Application for IC Chip Breakdown Prevention

TECHNICAL NOTES

Phase Compensation

Phase compensation is provided to secure stable operation even when the load current is varied. For this purpose, make sure to use 0.1 μF or more of a capacitor (C_{OUT}). In case of using a tantalum type capacitor and the ESR (Equivalent Series Resistance) value of the capacitor is large, the output might be unstable. Evaluate the circuit including consideration of frequency characteristics. Connect 0.1 μF or more of a capacitor (C_{IN}) between V_{DD} and GND, and as close as possible to the pins.

PCB Layout

For SOT-23-5 package type, wire the following GND pins together: No. 1 and No. 2

For SOT-89-5 package type, wire the following GND pins together: No. 2 and No. 4.

For HSOP-6J package type, wire the following GND pins together: No. 2, No. 4, and No. 5.

R1525x

No. EC-520-200422

Input Transient / Load Transient vs. Output Capacity (C_{OUT})

R1525x performs a stable operation by using 0.1 μF of ceramic capacitor as the output capacitor. However, the variation of output voltage may not meet the demand of the system when input voltage and load current vary. In such cases, the variation of output voltage can be minimized significantly by using 10 μF or higher ceramic capacitor. When using an electrolytic capacitor for the output line, place the electrolytic capacitor outer side of the ceramic capacitor arranged close to the IC.

<Input Transient Response>

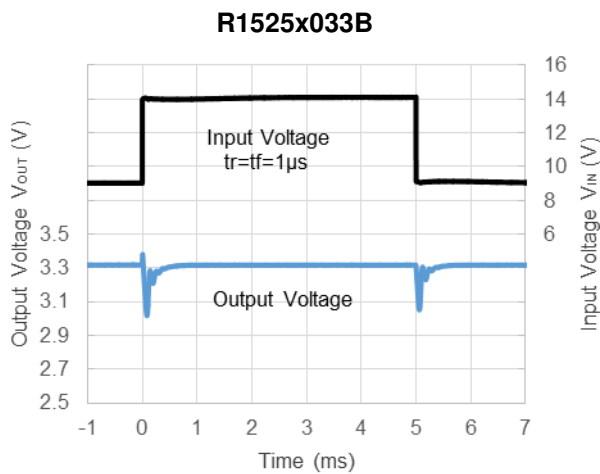

<Load Transient Response>

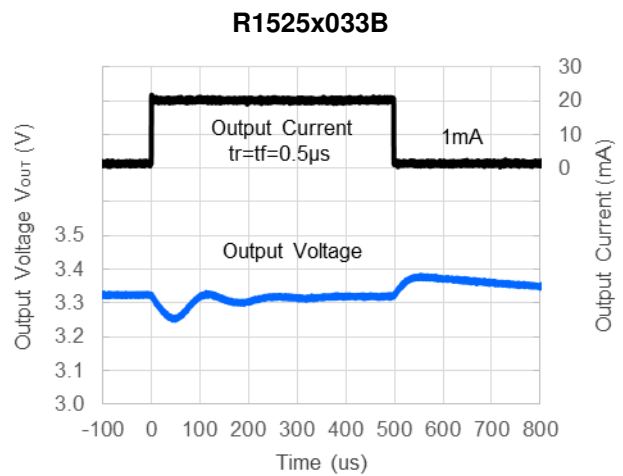

ESR vs. Output Current

Using a ceramic type capacitor is recommended for this device, but also other type capacitors having lower ESR can be used. The relation between the output current (I_{OUT}) and the ESR of output capacitor is shown below.

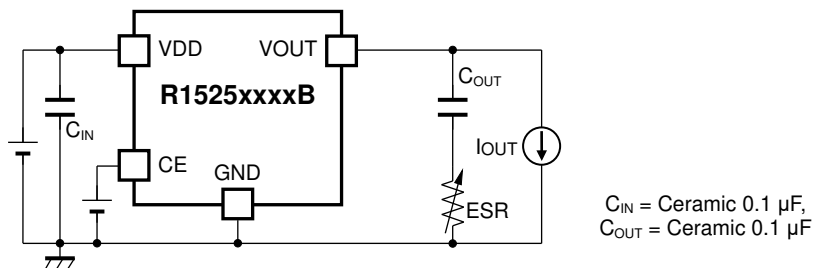

R1525x018B

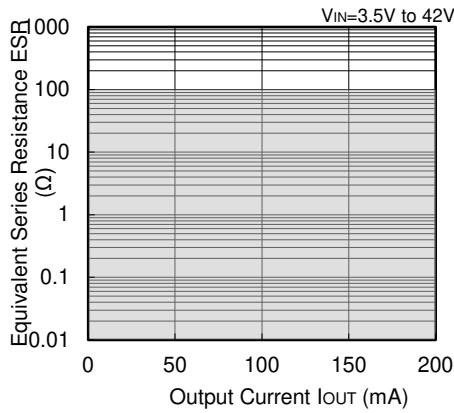

R1525x033B

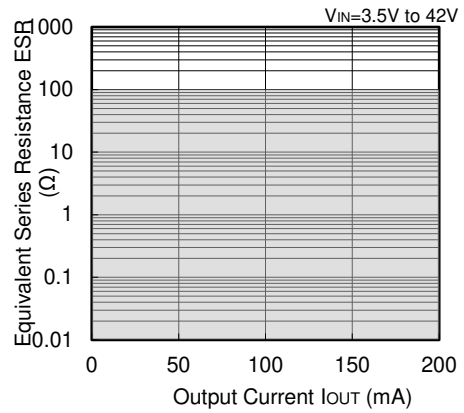

R1525x050B

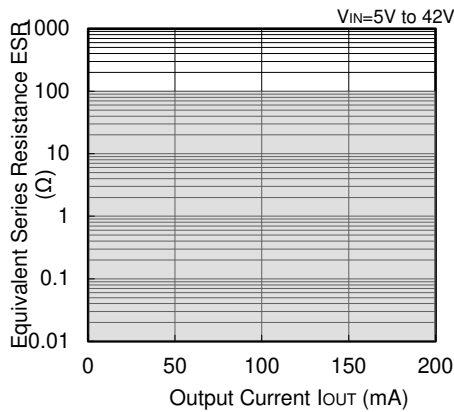

R1525x090B

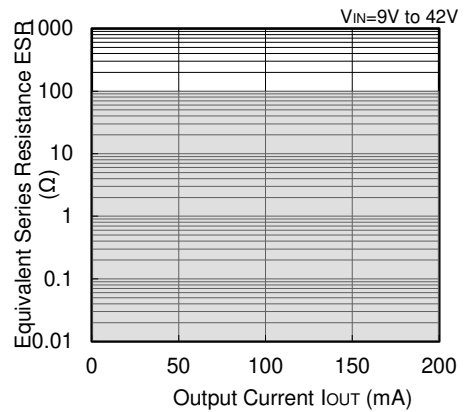

R1525x120B

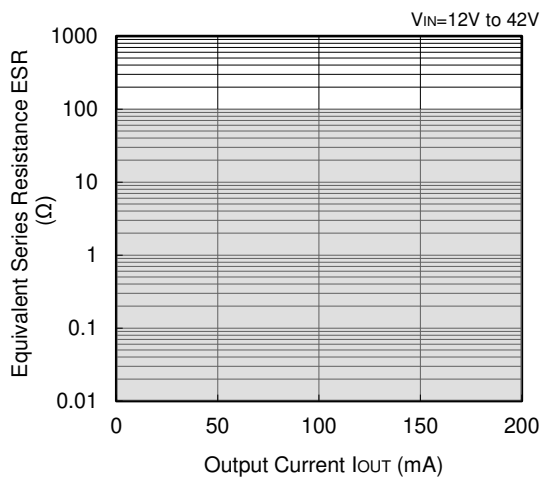

Measurement Conditions

Frequency Band: 10 Hz to 2 MHz

Measurement Temperature: -40°C to 125°C

Noise Level in Hatched Area:

40 μ V (average) or below

Ceramic Capacitors:

C_{IN} = 0.1 μ F, Murata, GRM188R71H104JA93D

C_{OUT} = 0.1 μ F, TDK, CGA3E2X7R1E104K

R1525x

No. EC-520-200422

TYPICAL CHARACTERISTICS

Typical Characteristics are intended to be used as reference data, they are not guaranteed.

1) Output Voltage vs. Output Current

R1525x018B

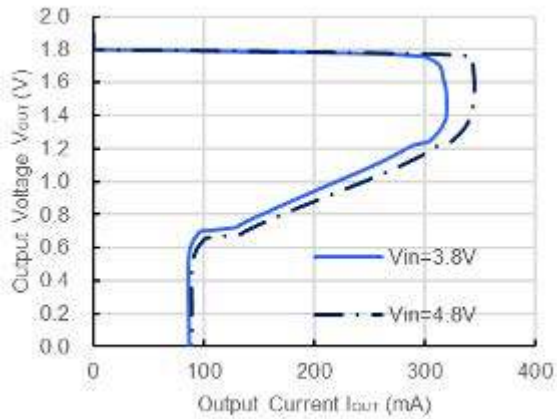

R1525x033B

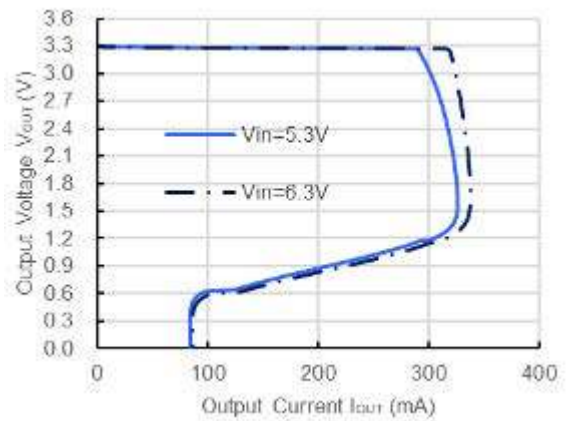

R1525x050B

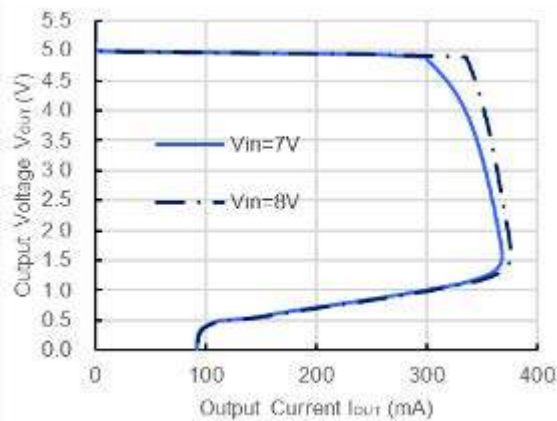

R1525x090B

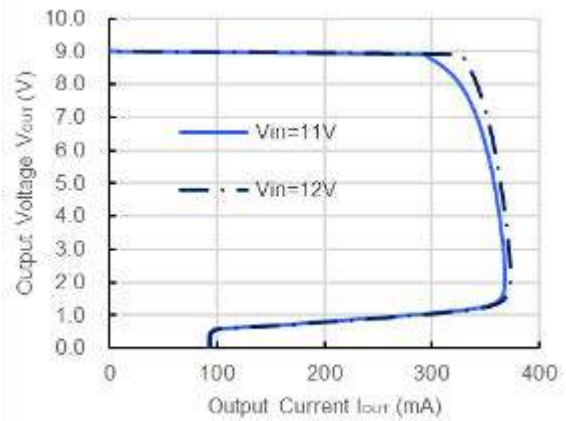

R1525x120B

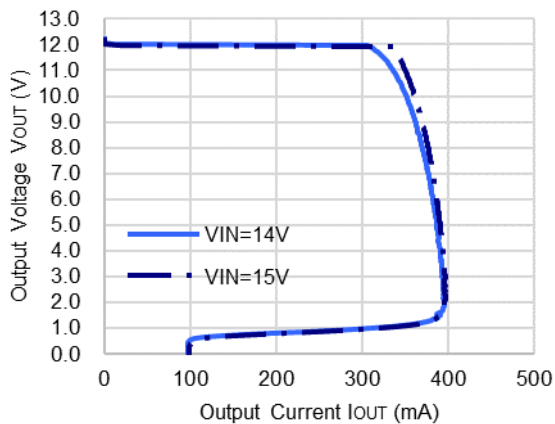

2) Output Voltage vs. Input Voltage

R1525x018B

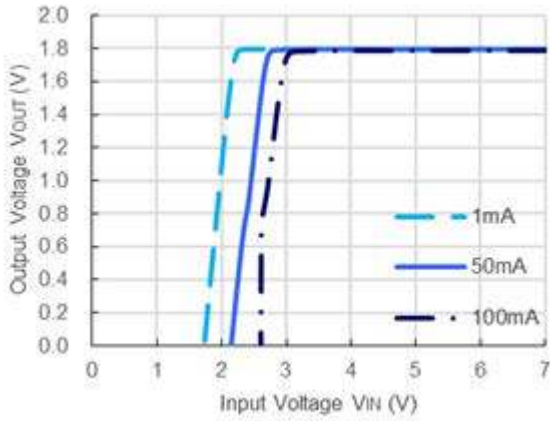

R1525x033B

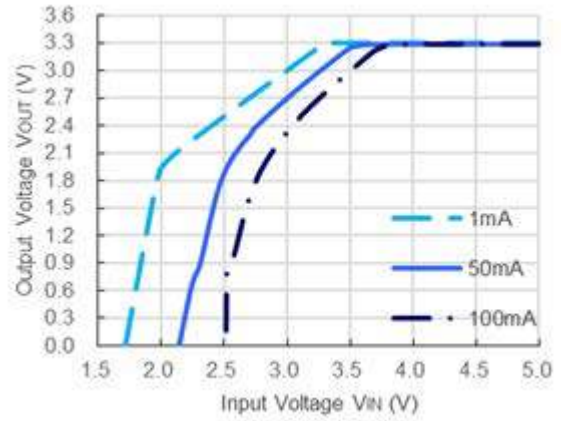

R1525x050B

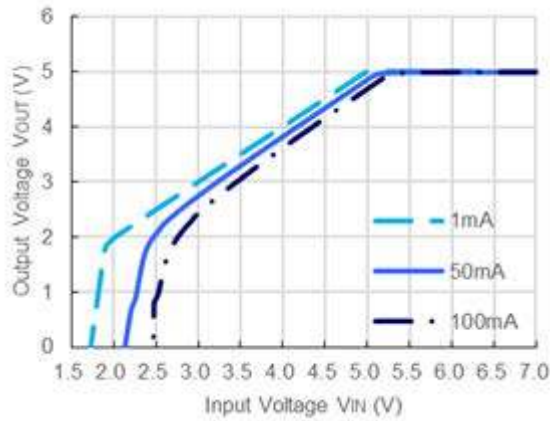

R1525x090B

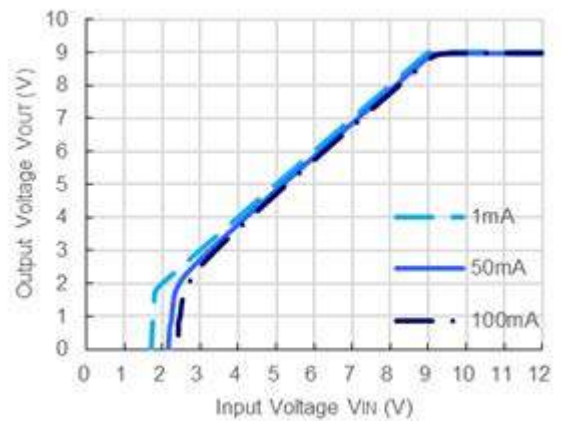

R1525x120B

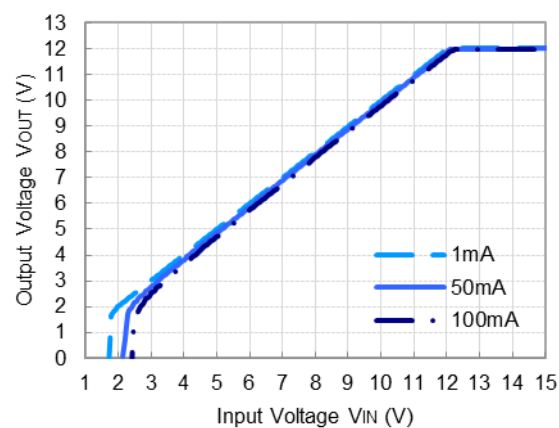

R1525x

No. EC-520-200422

3) Supply Current vs. Temperature

R1525x018B

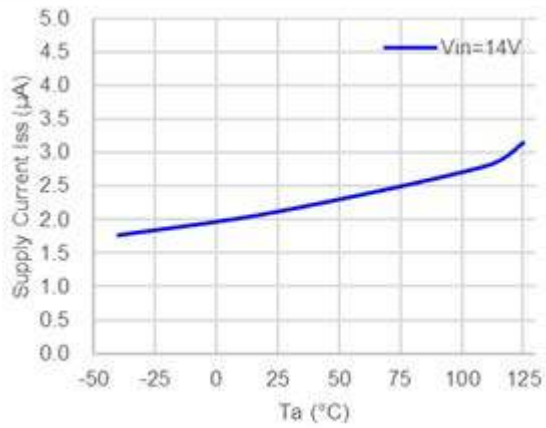

R1525x033B

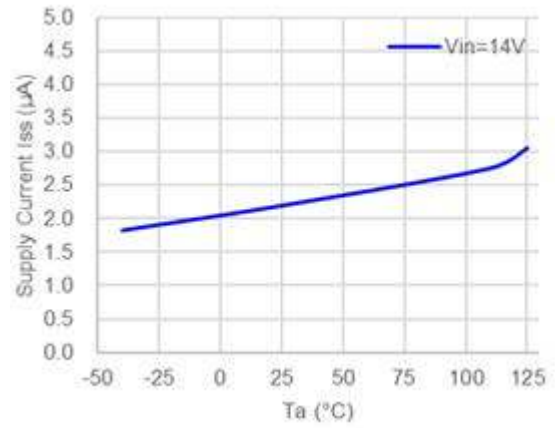

R1525x050B

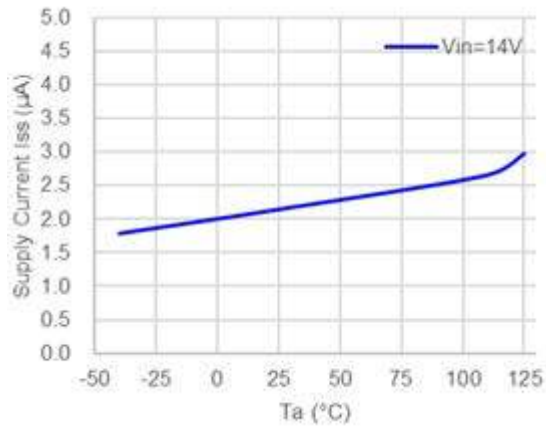

R1525x090B

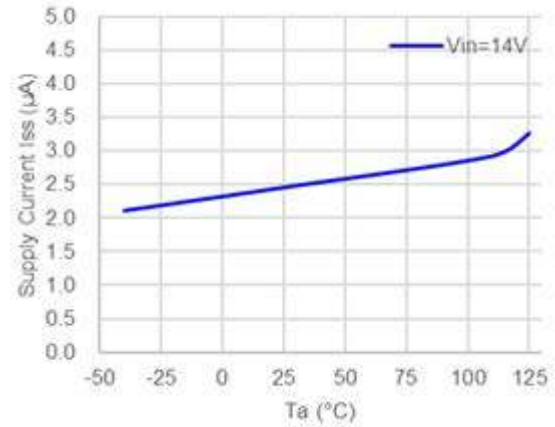

R1525x120B

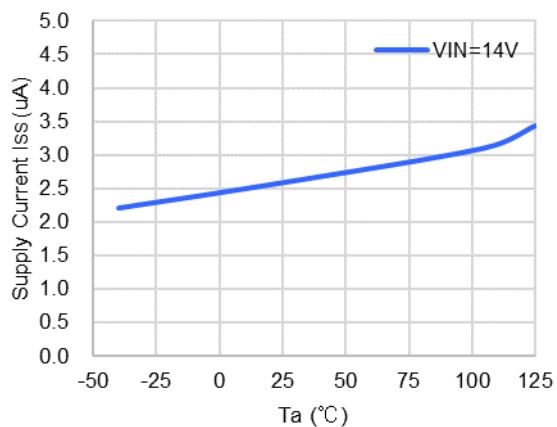

4) Supply Current vs. Input Voltage

R1525x018B

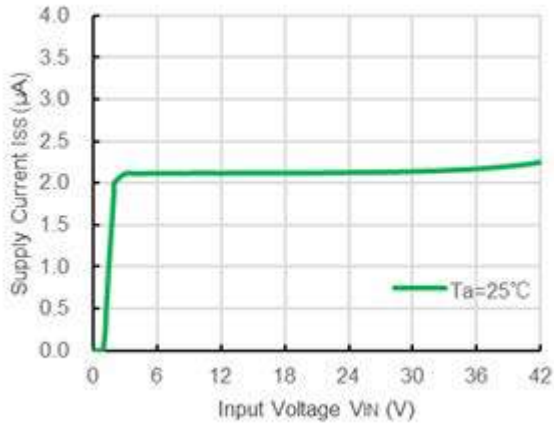

R1525x033B

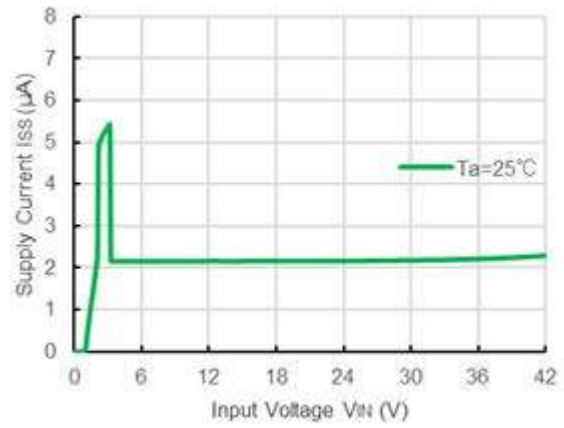

R1525x050B

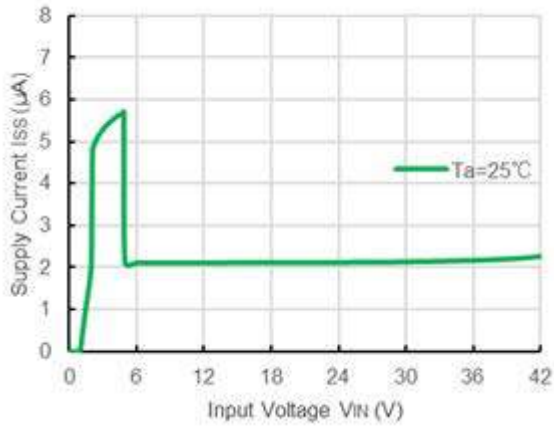

R1525x090B

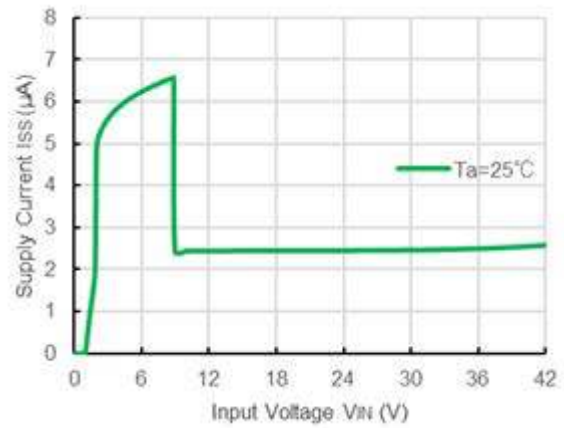

R1525x120B

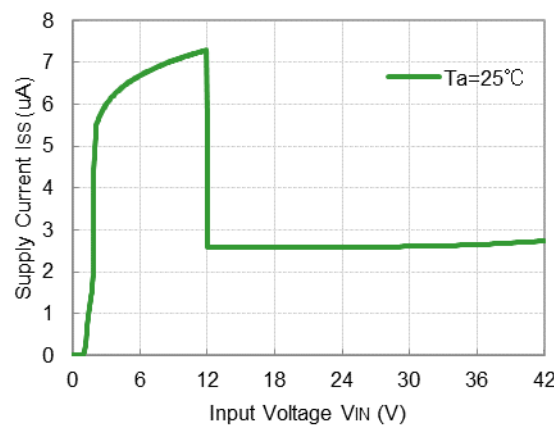

R1525x

No. EC-520-200422

5) Output Voltage vs. Temperature ($I_{OUT} = 1.0 \text{ mA}$)

R1525x018B

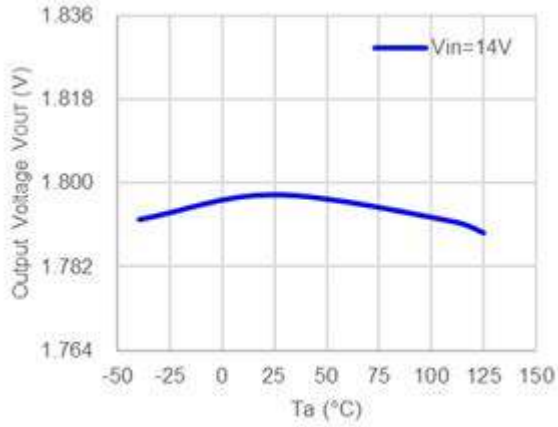

R1525x033B

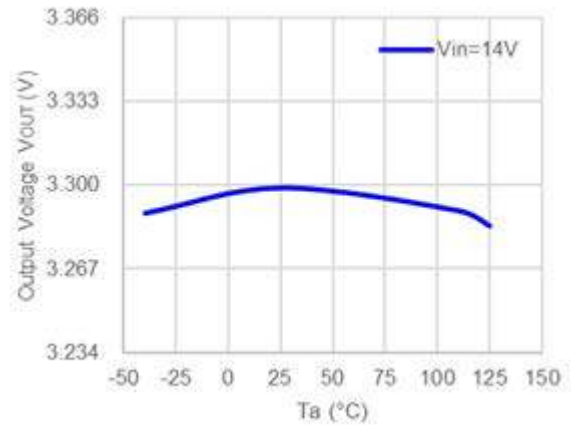

R1525x050B

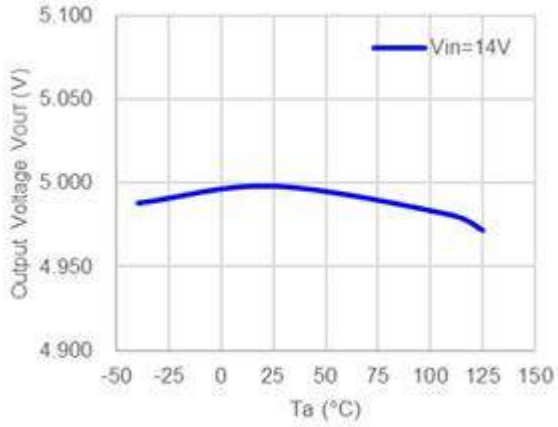

R1525x090B

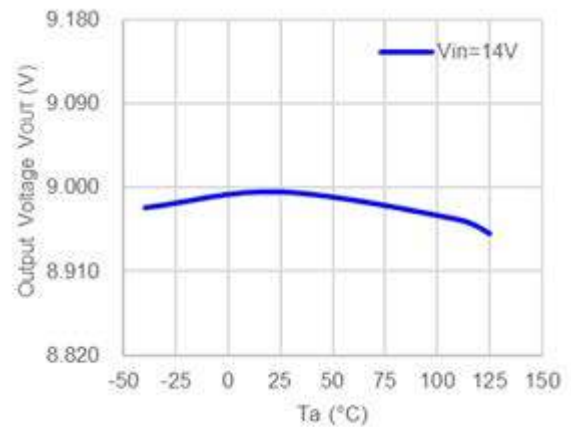

R1525x120B

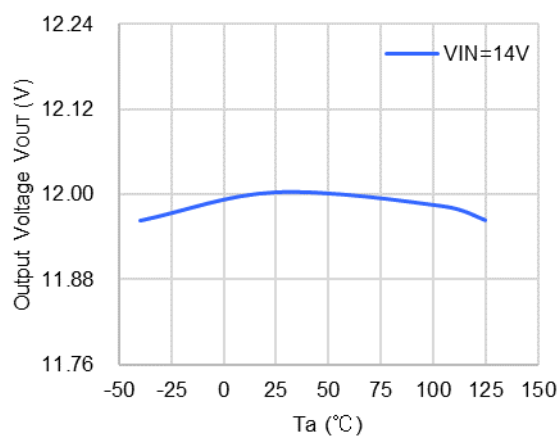

6) Dropout Voltage vs. Output Current

R1525x018B

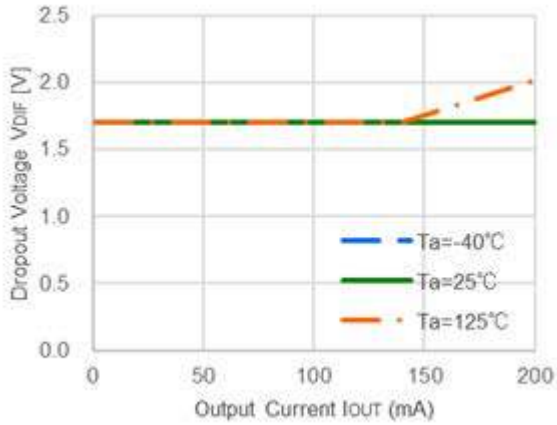

R1525x033B

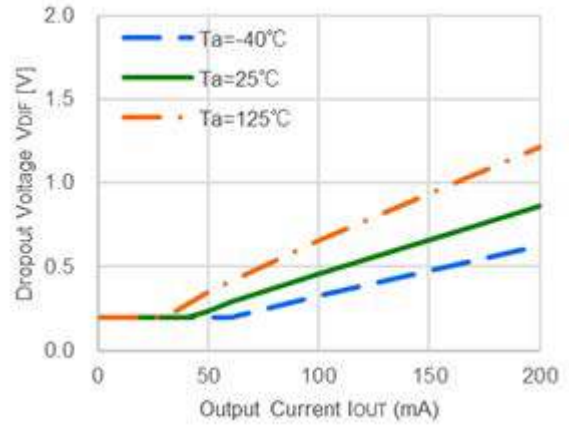

R1525x050B

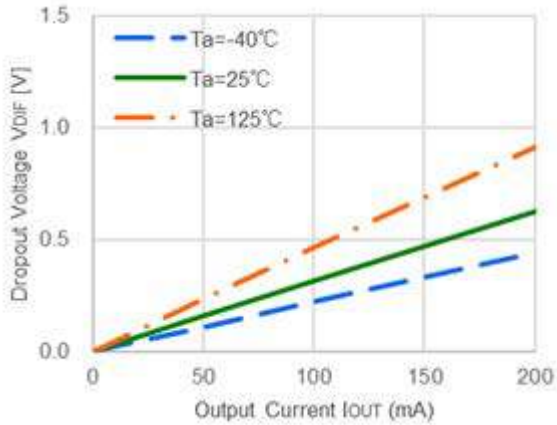

R1525x090B

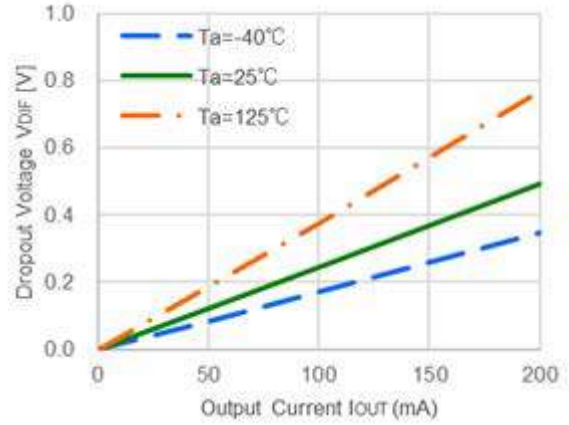

R1525x120B

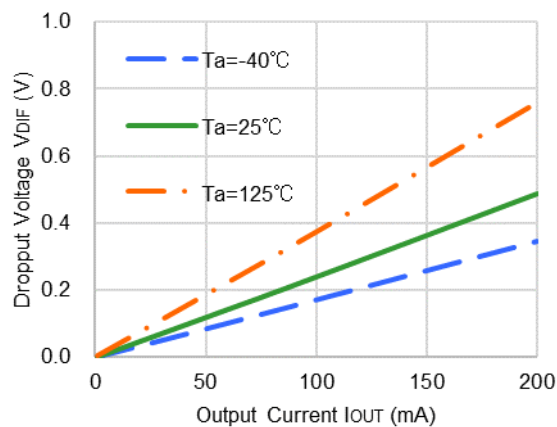

R1525x

No. EC-520-200422

7) Dropout Voltage vs. Output Voltage

$I_{OUT} = 1\text{ mA} / 50\text{ mA} / 100\text{ mA} / 200\text{ mA}$

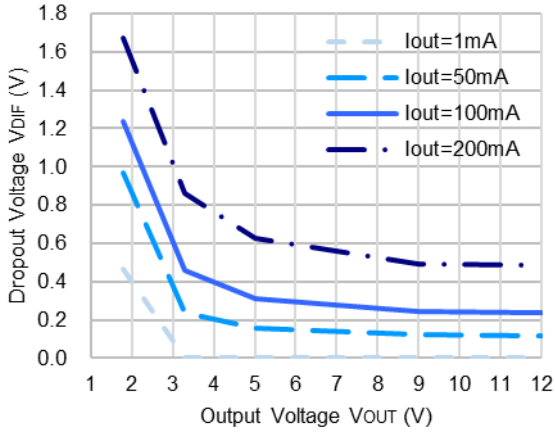

8) Ripple Rejection vs. Input Voltage

$I_{OUT} = 50\text{ mA}$, $V_{RIPPLE} = \pm 0.2\text{ V}$

R1525x018B

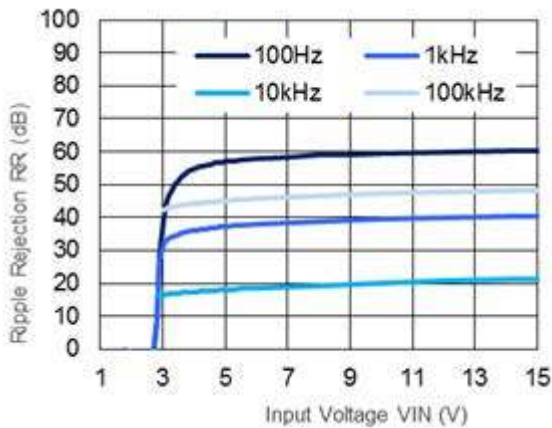

$I_{OUT} = 50\text{ mA}$, $V_{RIPPLE} = \pm 0.2\text{ V}$

R1525x033B

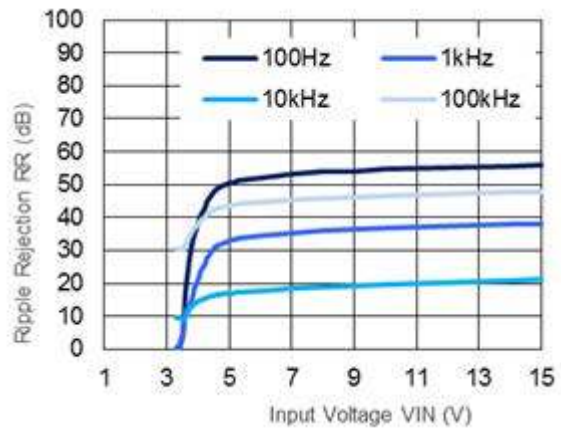

$I_{OUT} = 50\text{ mA}$, $V_{RIPPLE} = \pm 0.2\text{ V}$

R1525x050B

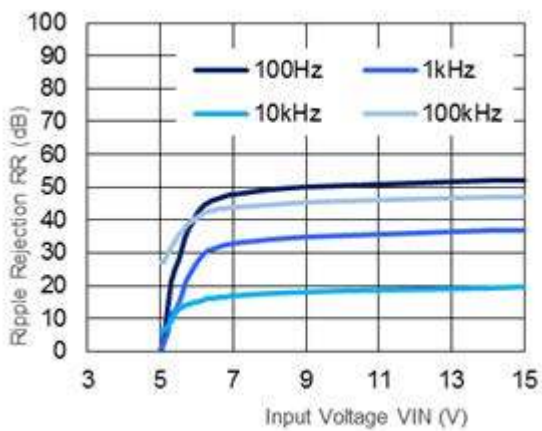

$I_{OUT} = 50\text{ mA}$, $V_{RIPPLE} = \pm 0.2\text{ V}$

R1525x090B

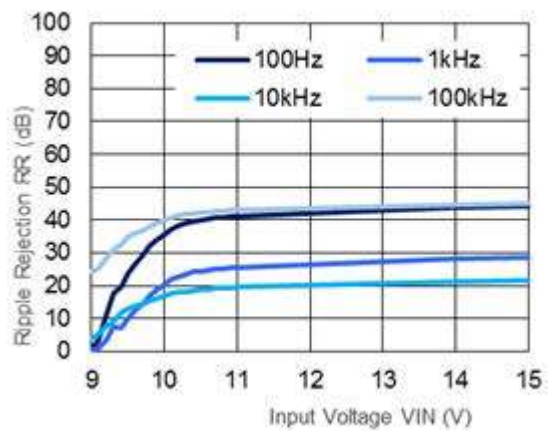

$I_{OUT} = 50 \text{ mA}$, $V_{RIPPLE} = \pm 0.2 \text{ V}$

R1525x120B

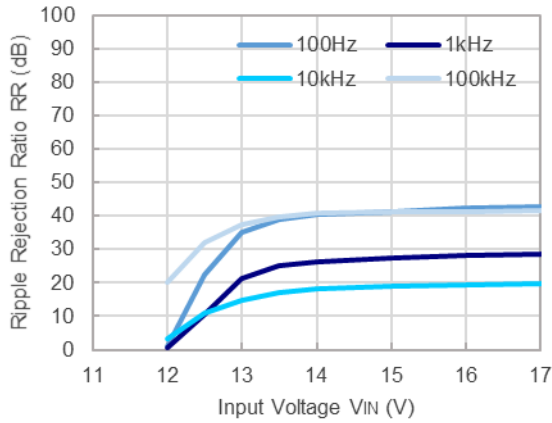

9) Ripple Rejection vs. Frequency

$V_{RIPPLE} = \pm 0.2 \text{ V}$

R1525x018B

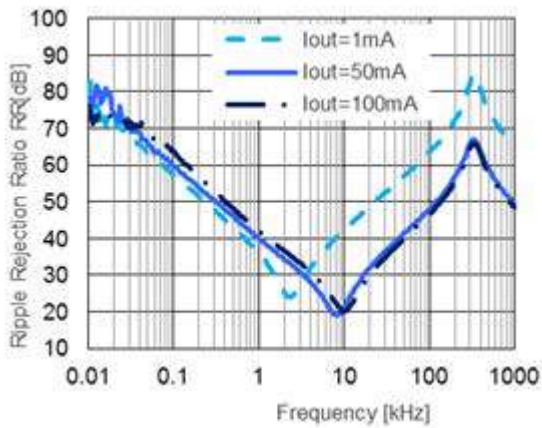

$V_{RIPPLE} = \pm 0.2 \text{ V}$

R1525x033B

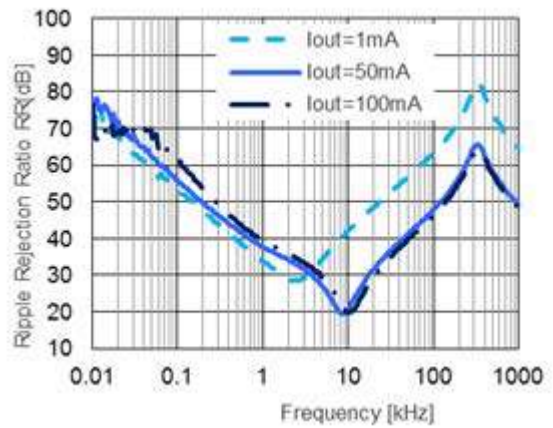

$V_{RIPPLE} = \pm 0.2 \text{ V}$

R1525x050B

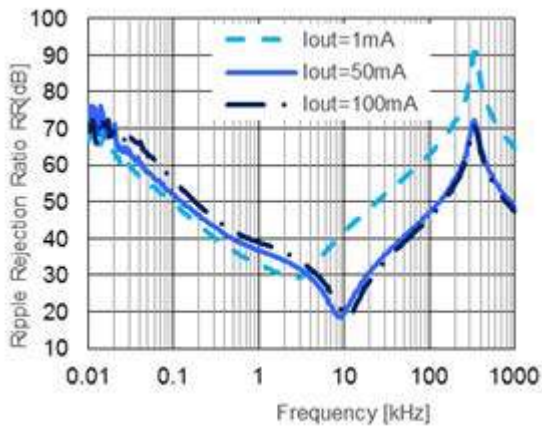

$V_{RIPPLE} = \pm 0.2 \text{ V}$

R1525x090B

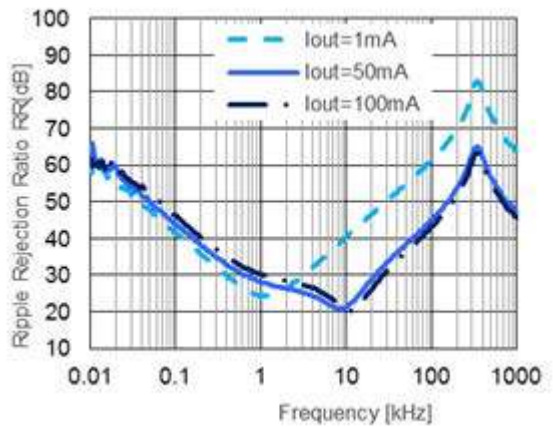

R1525x

No. EC-520-200422

$V_{RIPPLE} = \pm 0.2 \text{ V}$

R1525x120B

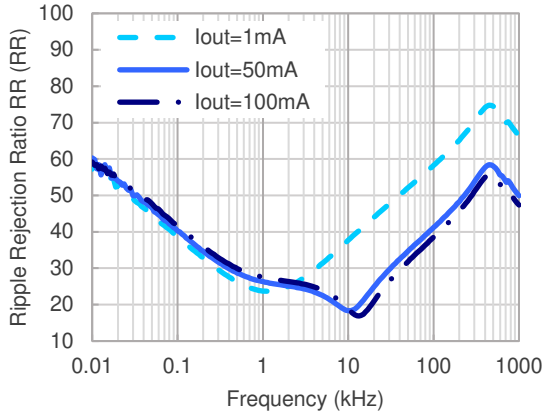

10) Input Transient Response

$I_{OUT} = 50 \text{ mA}$, $C_{OUT} = 10\mu\text{F}$
R1525x018B

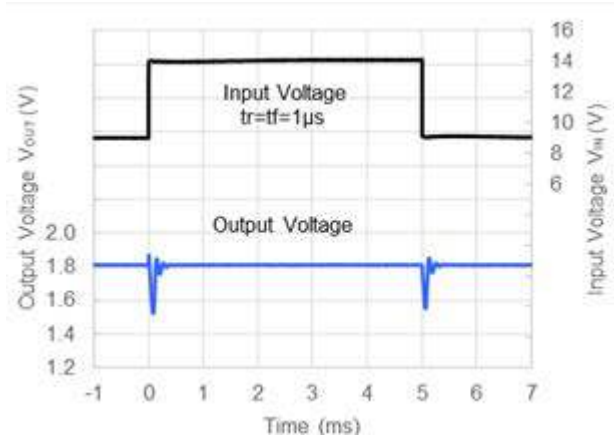

$I_{OUT} = 50 \text{ mA}$, $C_{OUT} = 10\mu\text{F}$
R1525x033B

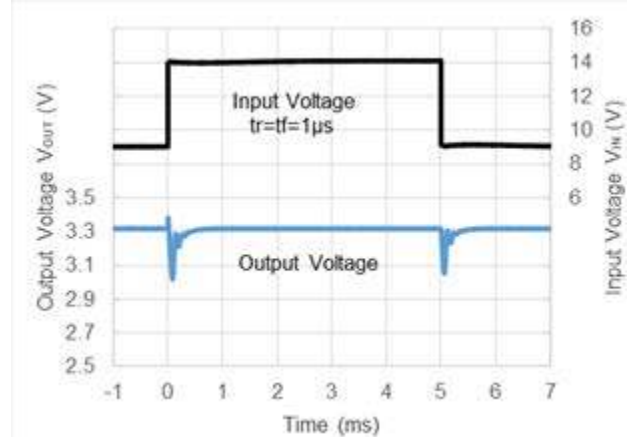

$I_{OUT} = 50 \text{ mA}$, $C_{OUT} = 10\mu\text{F}$
R1525x050B

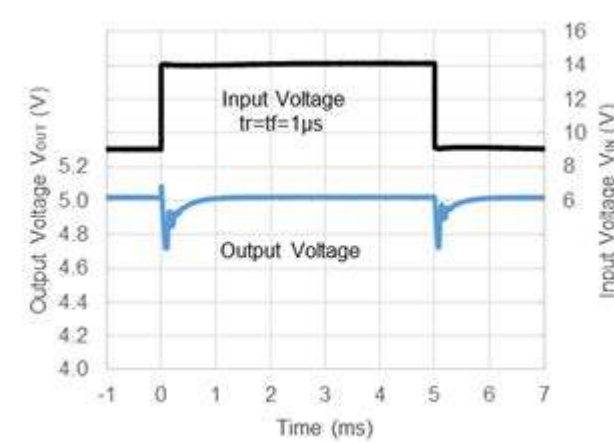

$I_{OUT} = 50 \text{ mA}$, $C_{OUT} = 10\mu\text{F}$
R1525x090B

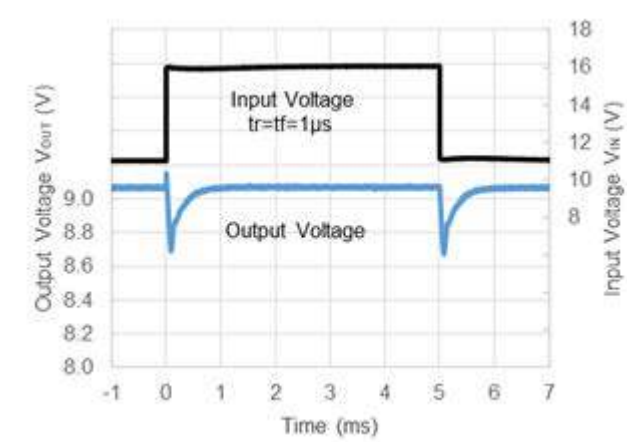

$I_{OUT} = 50 \text{ mA}$, $C_{OUT} = 10\mu\text{F}$
R1525x120B

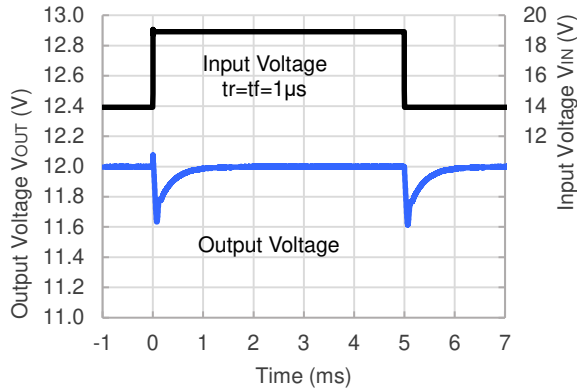

11) Load Transient Response

$V_{IN} = 14 \text{ V}$, $I_{OUT} = 1.0 \text{ mA} \rightarrow 20 \text{ mA}$, $C_{OUT} = 10\mu\text{F}$
R1525x018B

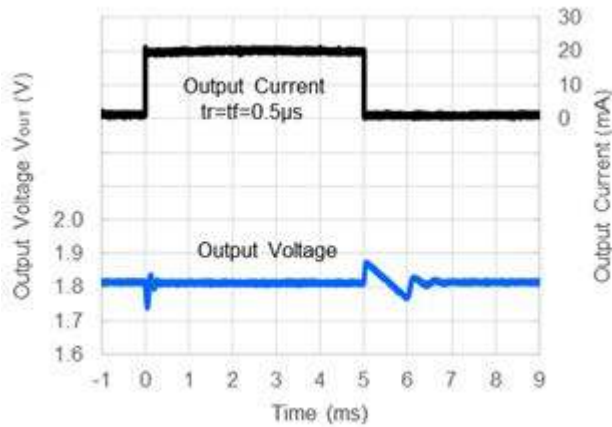

$V_{IN} = 14 \text{ V}$, $I_{OUT} = 1.0 \text{ mA} \rightarrow 20 \text{ mA}$, $C_{OUT} = 10\mu\text{F}$
R1525x033B

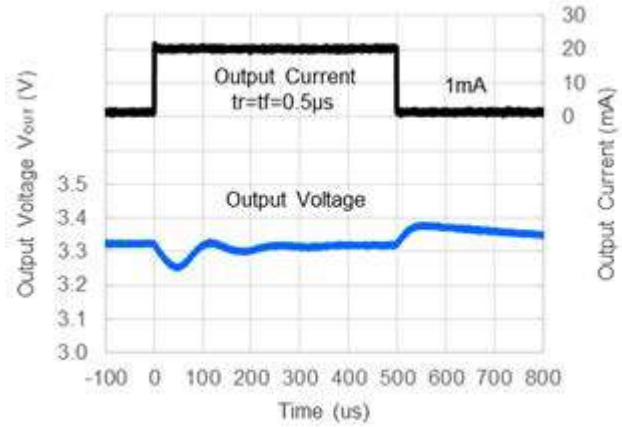

$V_{IN} = 14 \text{ V}$, $I_{OUT} = 1.0 \text{ mA} \rightarrow 20 \text{ mA}$, $C_{OUT} = 10\mu\text{F}$
R1525x050B

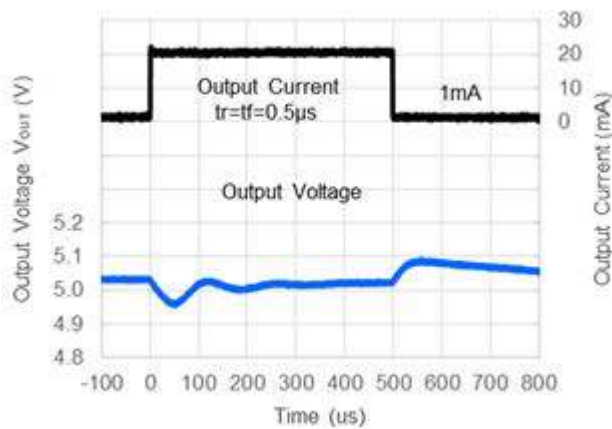

$V_{IN} = 14 \text{ V}$, $I_{OUT} = 1.0 \text{ mA} \rightarrow 20 \text{ mA}$, $C_{OUT} = 10\mu\text{F}$
R1525x090B

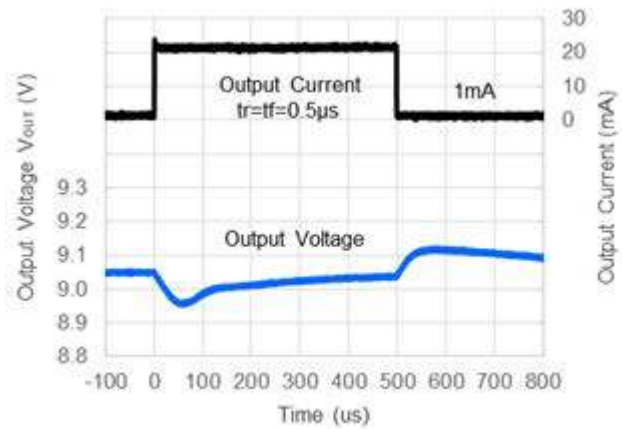

R1525x

No. EC-520-200422

$V_{IN} = 14\text{ V}$, $I_{OUT} = 1.0\text{ mA} \rightarrow 20\text{ mA}$, $C_{OUT} = 10\mu\text{F}$
R1525x120B

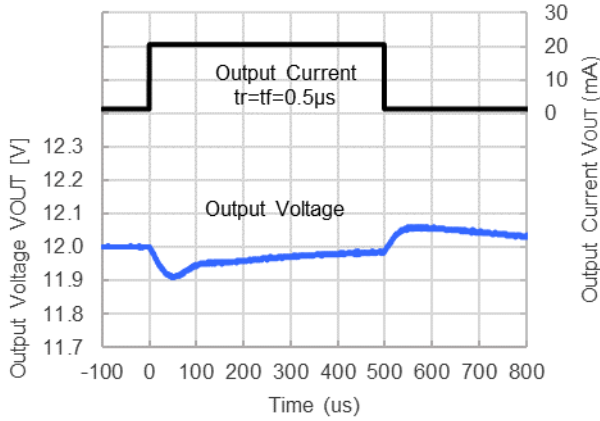

12) CE Transient Response

$V_{IN} = 14\text{ V}$, $V_{CE} = 0\text{ V} \rightarrow 14\text{ V}$
R1525x018B

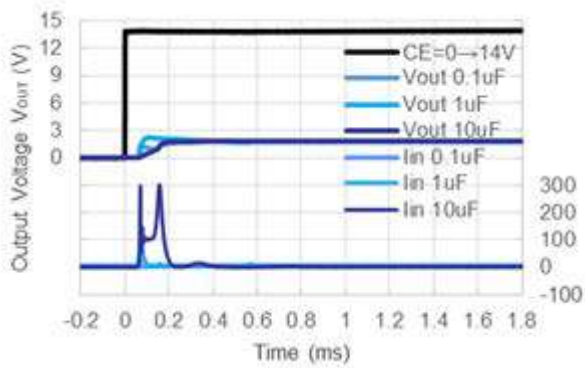

$V_{IN} = 14\text{ V}$, $V_{CE} = 14\text{ V} \rightarrow 0\text{ V}$
R1525x018B

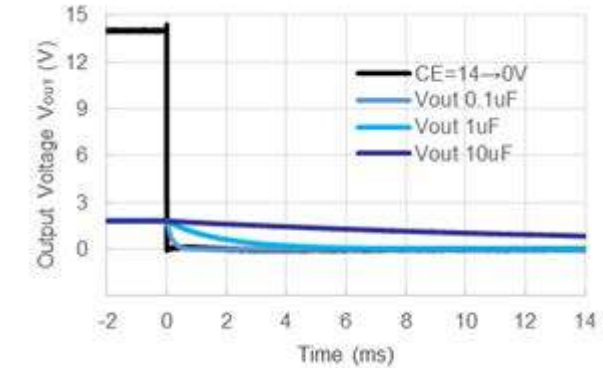

$V_{IN} = 14\text{ V}$, $V_{CE} = 0\text{ V} \rightarrow 14\text{ V}$
R1525x050B

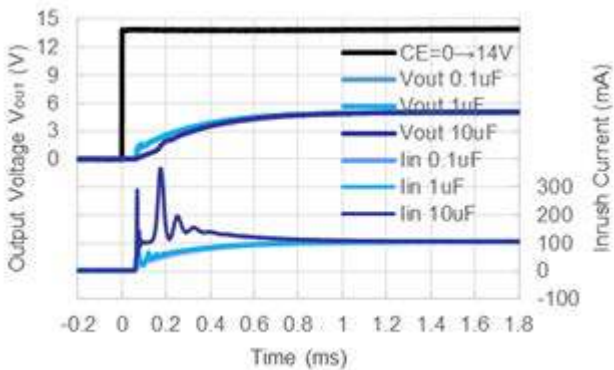

$V_{IN} = 14\text{ V}$, $V_{CE} = 14\text{ V} \rightarrow 0\text{ V}$
R1525x050B

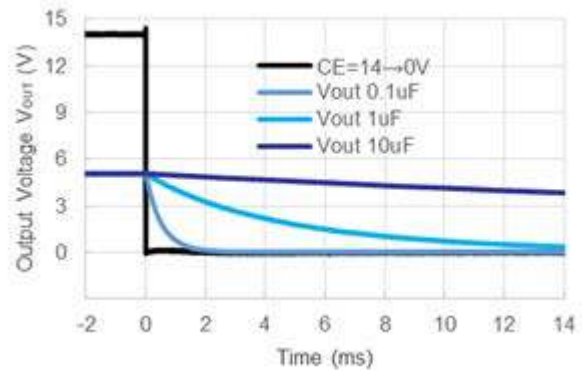

$V_{IN} = 14\text{ V}, V_{CE} = 0\text{ V} \rightarrow 14\text{ V}$
R1525x120B

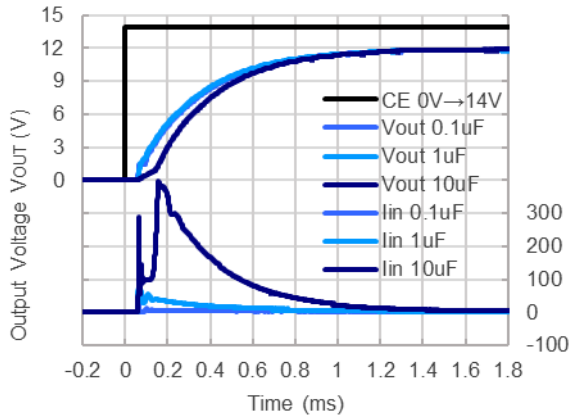

$V_{IN} = 14\text{ V}, V_{CE} = 14\text{ V} \rightarrow 0\text{ V}$
R1525x120B

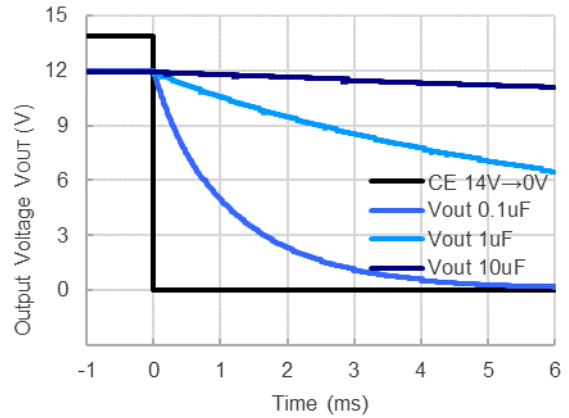

13) Power-on Transient Response

$V_{IN} = 0\text{ V} \rightarrow 14\text{ V}, V_{CE} = 5\text{ V}$
R1525x018B

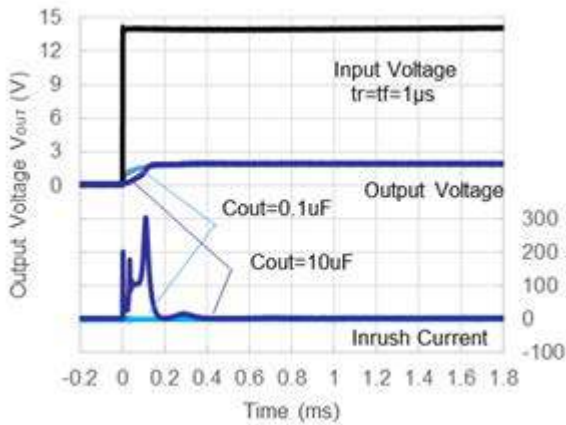

$V_{IN} = 0\text{ V} \rightarrow 14\text{ V}, V_{CE} = 5\text{ V}$
R1525x033B

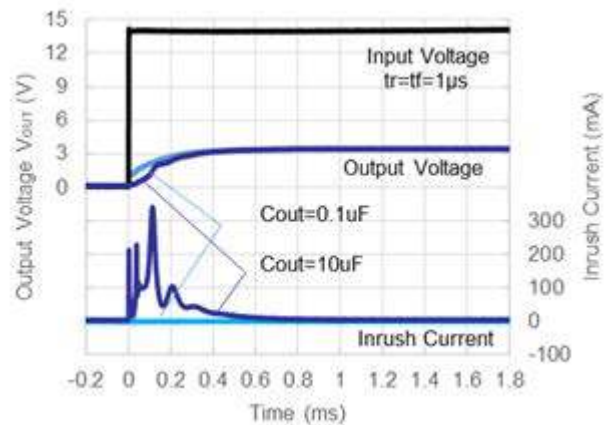

$V_{IN} = 0\text{ V} \rightarrow 14\text{ V}, V_{CE} = 5\text{ V}$
R1525x050B

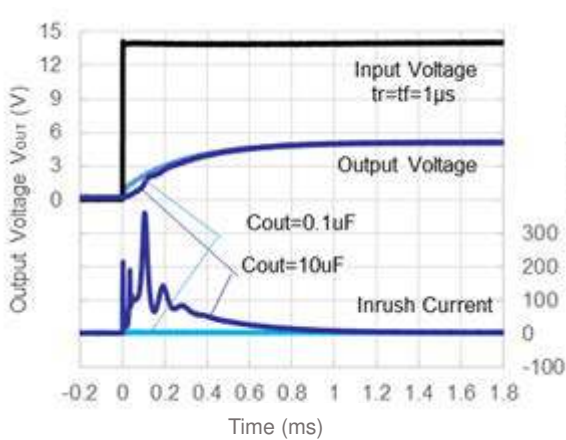

R1525x090B

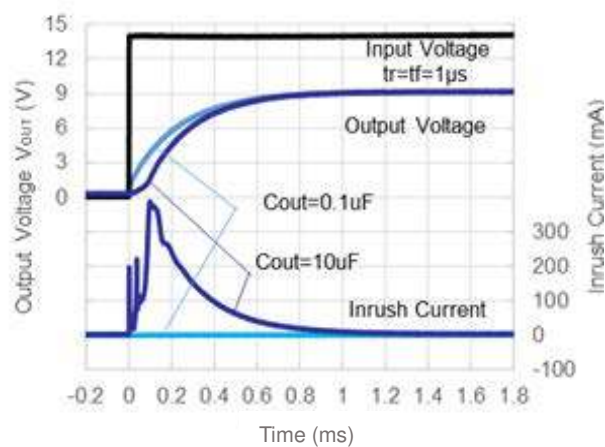

R1525x

No. EC-520-200422

$V_{IN} = 0\text{ V} \rightarrow 14\text{ V}$, $V_{CE} = 5\text{ V}$
R1525x120B

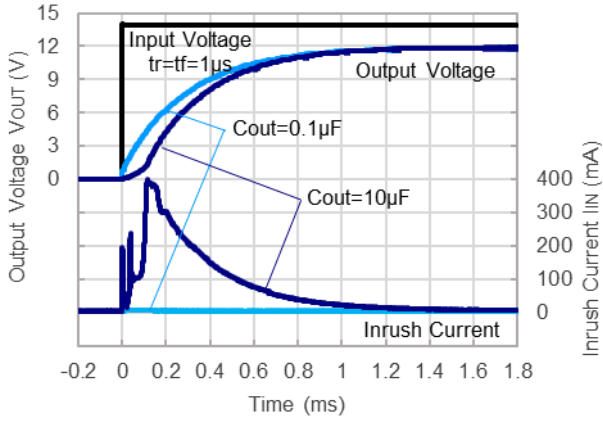

14) Load Dump

$V_{IN} = 12\text{ V} \rightarrow 50\text{ V}$, $V_{CE} = V_{IN}$, $I_{OUT} = 1.0\text{ mA}$
R1525x050B

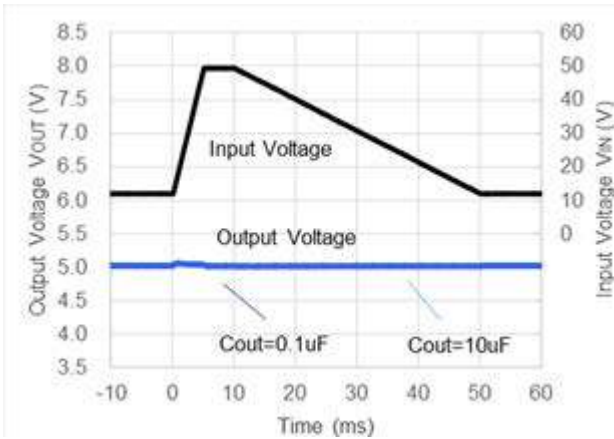

$V_{IN} = 12\text{ V} \rightarrow 50\text{ V}$, $V_{CE} = V_{IN}$, $I_{OUT} = 1.0\text{ mA}$
R1525x090B

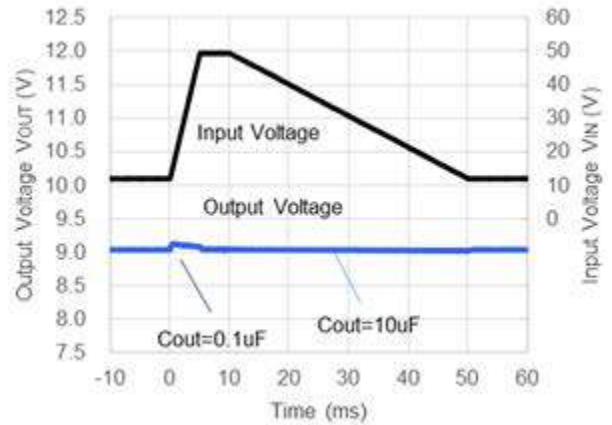

$V_{IN} = 12\text{ V} \rightarrow 50\text{ V}$, $V_{CE} = V_{IN}$, $I_{OUT} = 1.0\text{ mA}$
R1525x120B

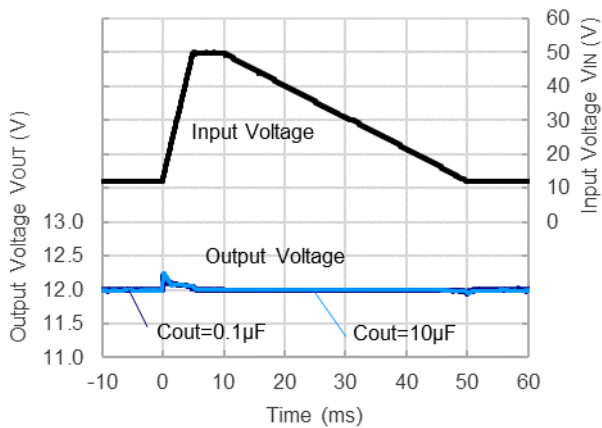

15) Cranking

$V_{IN} = 14\text{ V} \rightarrow 3.5\text{ V} \rightarrow 10\text{ V}$, $I_{OUT} = 1.0\text{ mA}$
R1525x050B

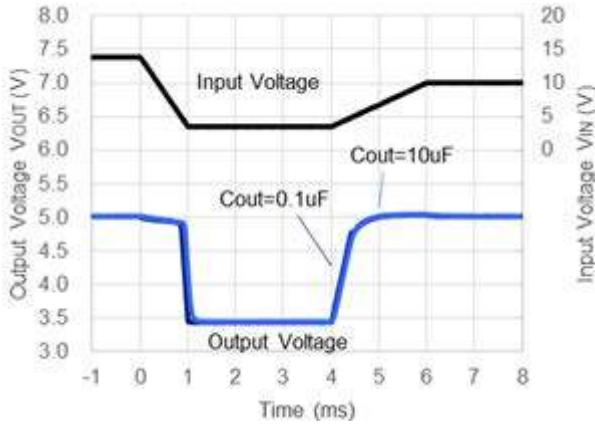

$V_{IN} = 14\text{ V} \rightarrow 3.5\text{ V} \rightarrow 10\text{ V}$, $I_{OUT} = 1.0\text{ mA}$
R1525x090B

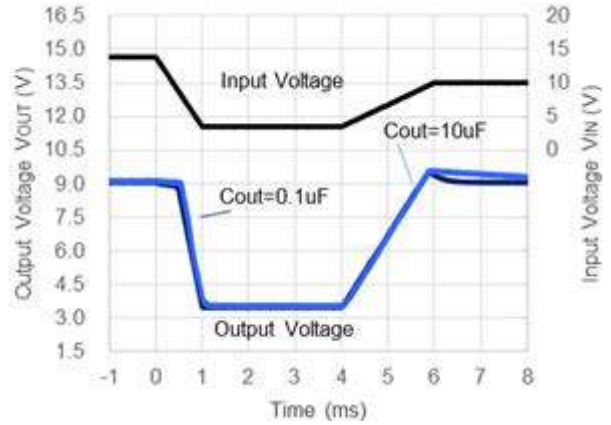

$V_{IN} = 14\text{ V} \rightarrow 3.5\text{ V} \rightarrow 10\text{ V}$, $I_{OUT} = 1.0\text{ mA}$
R1525x120B

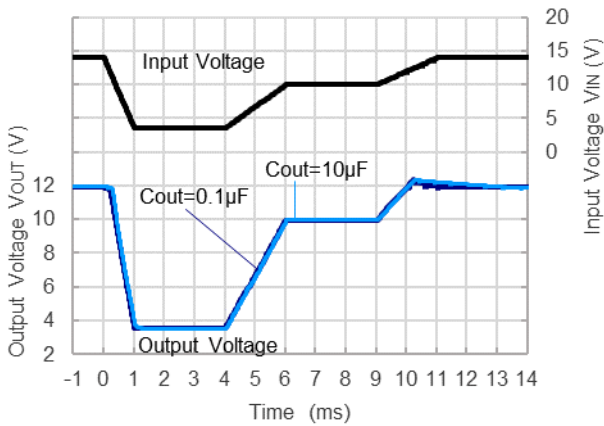

16) DPI (VOUT Pin impressed at 1W)

$V_{IN} = 14\text{ V}$

R1525x033B

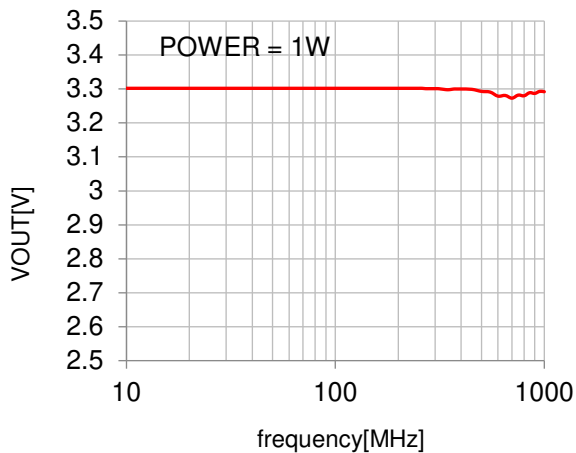

$V_{IN} = 14\text{ V}$

R1525x050B

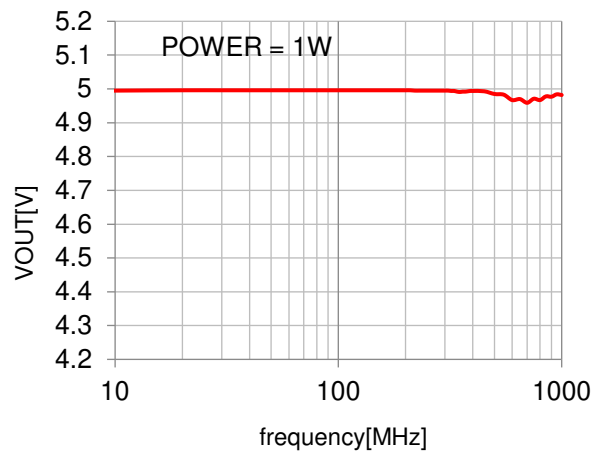

The power dissipation of the package is dependent on PCB material, layout, and environmental conditions. The following measurement conditions are based on JEDEC STD. 51-7.

Measurement Conditions

Item	Measurement Conditions
Environment	Mounting on Board (Wind Velocity = 0 m/s)
Board Material	Glass Cloth Epoxy Plastic (Four-Layer Board)
Board Dimensions	76.2 mm × 114.3 mm × 0.8 mm
Copper Ratio	Outer Layer (First Layer): Less than 95% of 50 mm Square Inner Layers (Second and Third Layers): Approx. 100% of 50 mm Square Outer Layer (Fourth Layer): Approx. 100% of 50 mm Square
Through-holes	φ 0.3 mm × 7 pcs

Measurement Result

(Ta = 25°C, Tjmax = 150°C)

Item	Measurement Result
Power Dissipation	830 mW
Thermal Resistance (θja)	θja = 150°C/W
Thermal Characterization Parameter (ψjt)	ψjt = 51°C/W

θja: Junction-to-Ambient Thermal Resistance

ψjt: Junction-to-Top Thermal Characterization Parameter

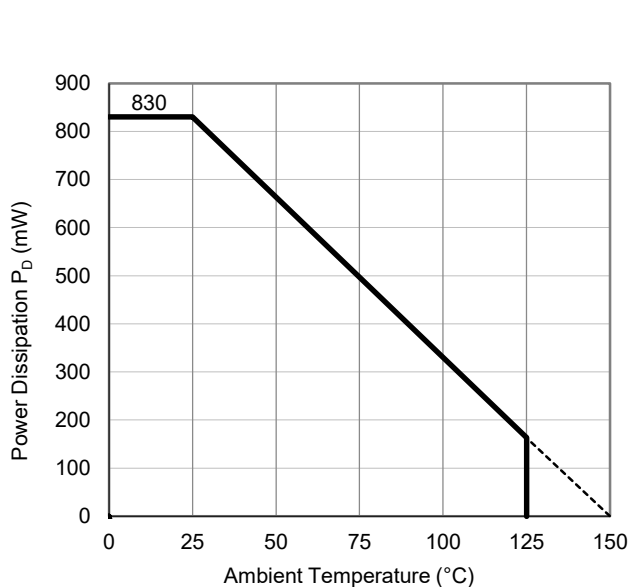

Power Dissipation vs. Ambient Temperature

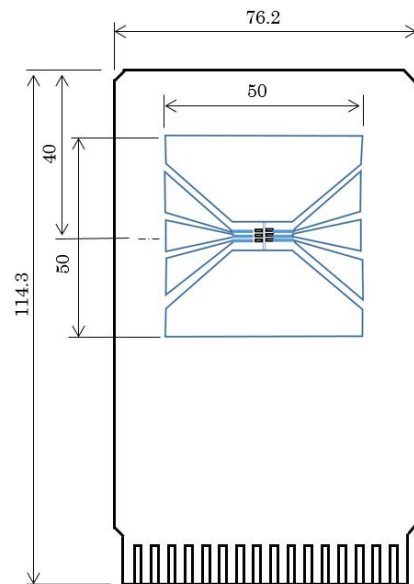

Measurement Board Pattern

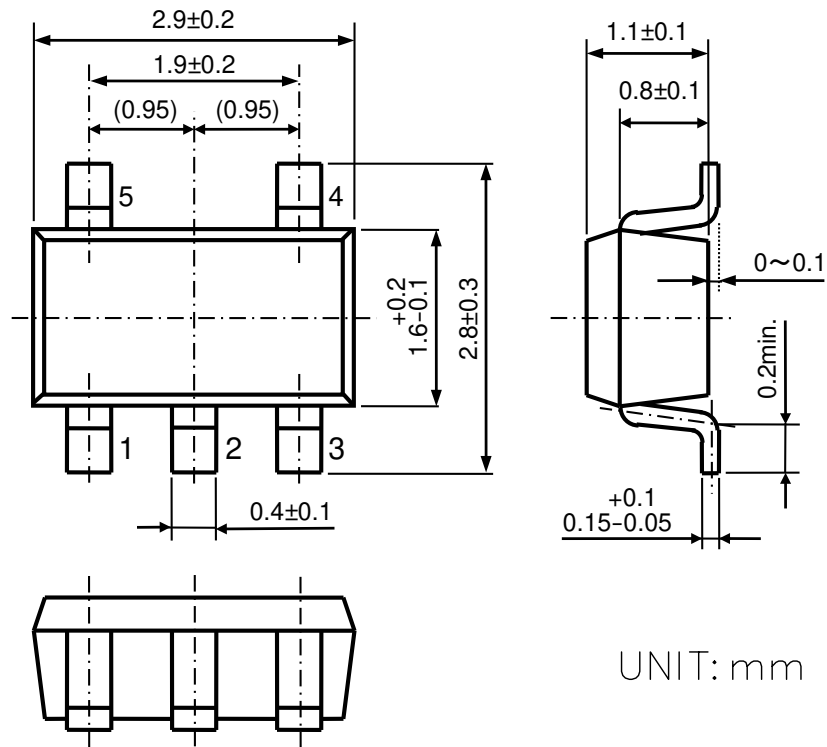

UNIT: mm

SOT-23-5 Package Dimensions

The power dissipation of the package is dependent on PCB material, layout, and environmental conditions. The following measurement conditions are based on JEDEC STD. 51-7.

Measurement Conditions

Item	Measurement Conditions
Environment	Mounting on Board (Wind Velocity = 0 m/s)
Board Material	Glass Cloth Epoxy Plastic (Four-Layer Board)
Board Dimensions	76.2 mm × 114.3 mm × 0.8 mm
Copper Ratio	Outer Layer (First Layer): Less than 95% of 50 mm Square Inner Layers (Second and Third Layers): Approx. 100% of 50 mm Square Outer Layer (Fourth Layer): Approx. 100% of 50 mm Square
Through-holes	φ 0.3 mm × 13 pcs

Measurement Result

(Ta = 25°C, Tjmax = 150°C)

Item	Measurement Result
Power Dissipation	3200 mW
Thermal Resistance (θja)	θja = 38°C/W
Thermal Characterization Parameter (ψjt)	ψjt = 13°C/W

θja: Junction-to-Ambient Thermal Resistance

ψjt: Junction-to-Top Thermal Characterization Parameter

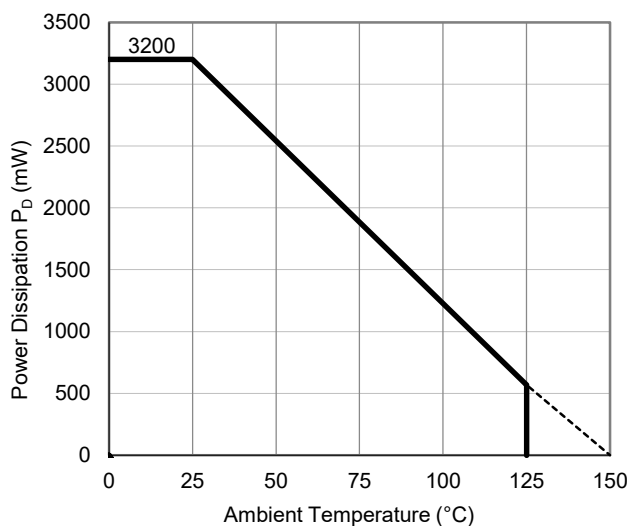

Power Dissipation vs. Ambient Temperature

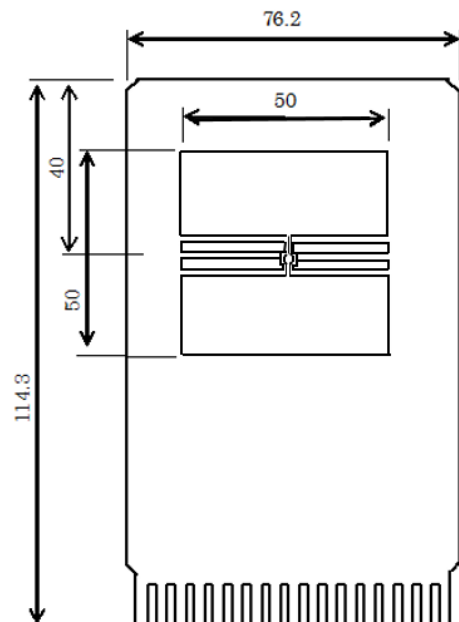

Measurement Board Pattern

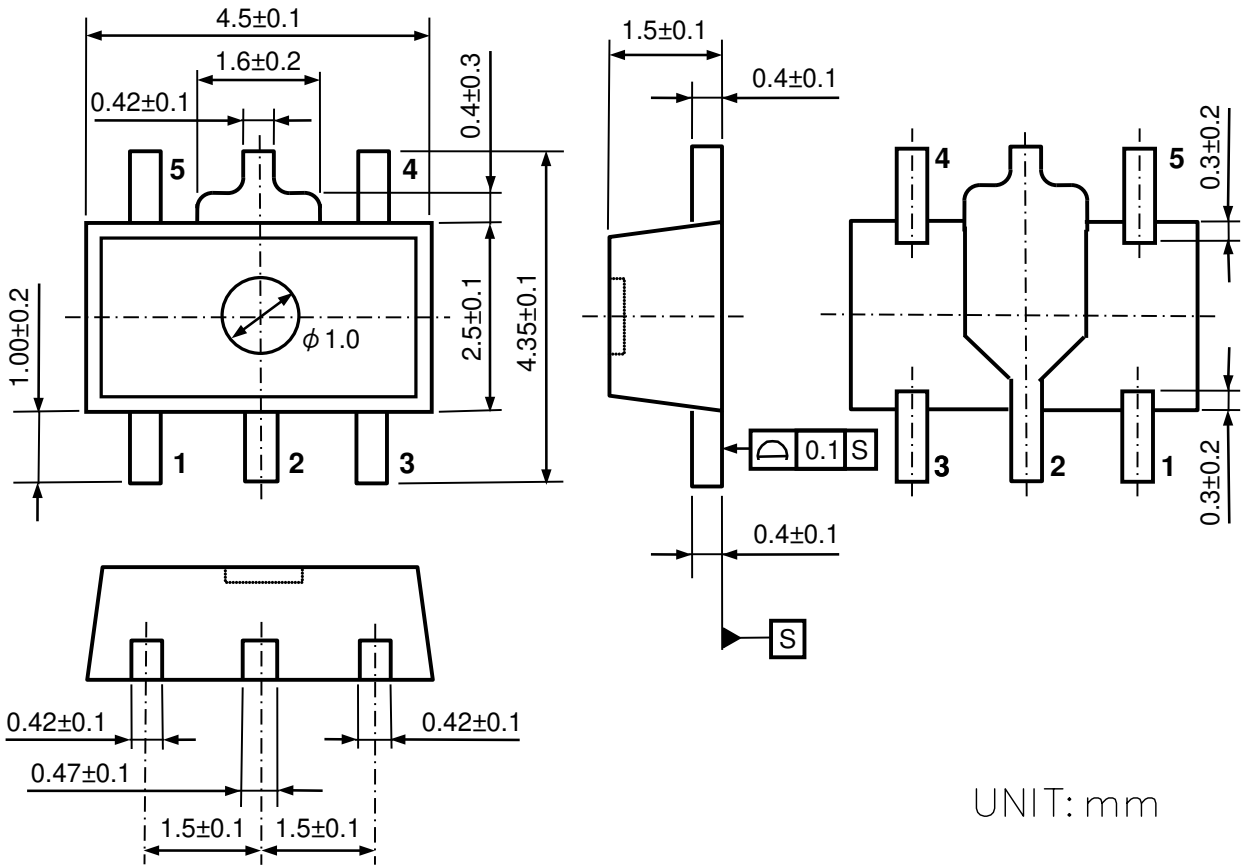

UNIT: mm

SOT-89-5 Package Dimensions

The power dissipation of the package is dependent on PCB material, layout, and environmental conditions. The following measurement conditions are based on JEDEC STD. 51-7.

Measurement Conditions

Item	Measurement Conditions
Environment	Mounting on Board (Wind Velocity = 0 m/s)
Board Material	Glass Cloth Epoxy Plastic (Four-Layer Board)
Board Dimensions	76.2 mm × 114.3 mm × 0.8 mm
Copper Ratio	Outer Layer (First Layer): Less than 95% of 50 mm Square Inner Layers (Second and Third Layers): Approx. 100% of 50 mm Square Outer Layer (Fourth Layer): Approx. 100% of 50 mm Square
Through-holes	φ 0.3 mm × 28 pcs

Measurement Result

(Ta = 25°C, Tjmax = 150°C)

Item	Measurement Result
Power Dissipation	3400 mW
Thermal Resistance (θ_{ja})	$\theta_{ja} = 37^{\circ}\text{C/W}$
Thermal Characterization Parameter (ψ_{jt})	$\psi_{jt} = 7^{\circ}\text{C/W}$

θ_{ja} : Junction-to-Ambient Thermal Resistance

ψ_{jt} : Junction-to-Top Thermal Characterization Parameter

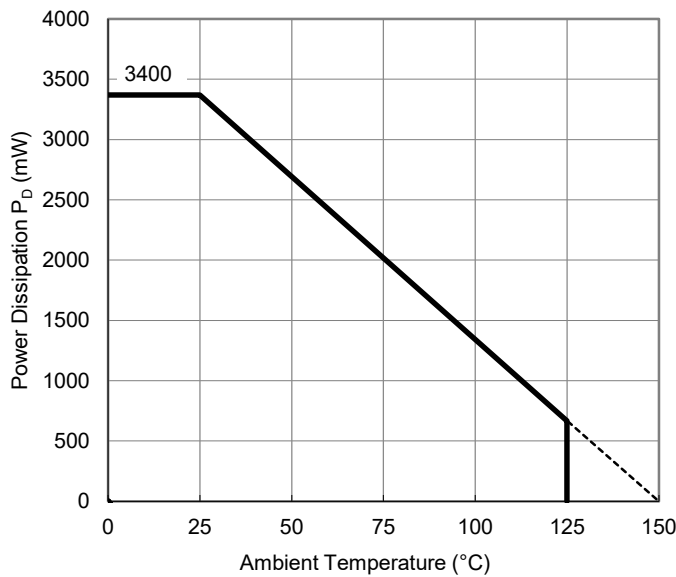

Power Dissipation vs. Ambient Temperature

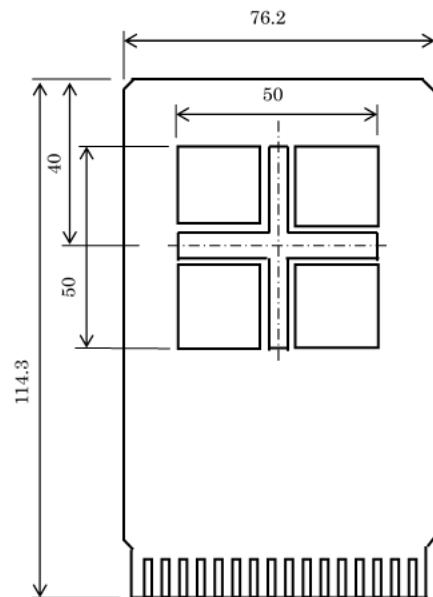

Measurement Board Pattern

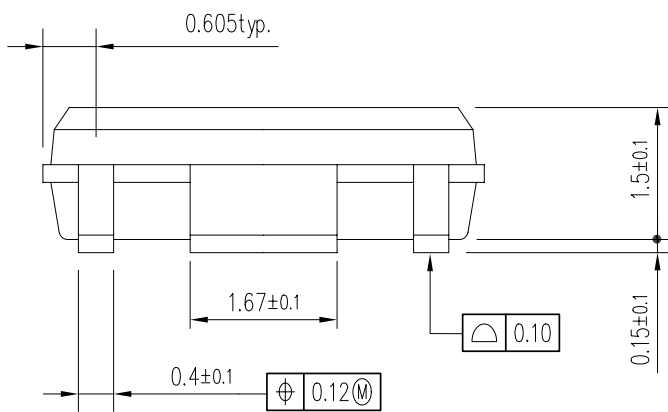
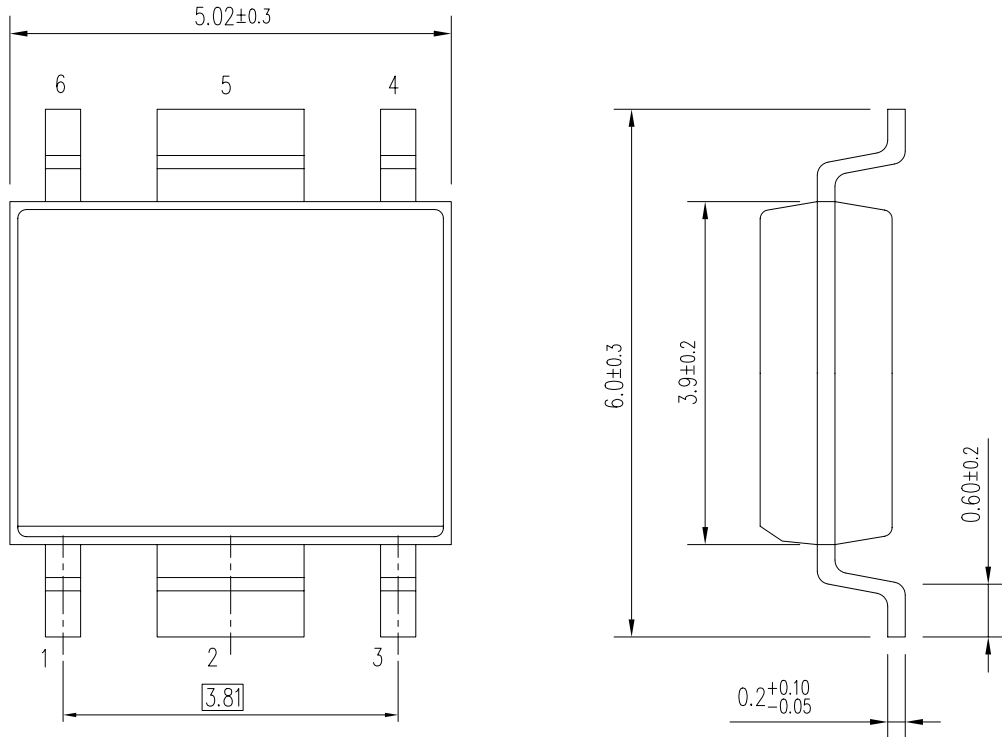

UNIT: mm

HSOP-6J Package Dimensions

The power dissipation of the package is dependent on PCB material, layout, and environmental conditions. The following measurement conditions are based on JEDEC STD. 51-7.

Measurement Conditions

Item	Measurement Conditions
Environment	Mounting on Board (Wind Velocity = 0 m/s)
Board Material	Glass Cloth Epoxy Plastic (Four-Layer Board)
Board Dimensions	76.2 mm × 114.3 mm × 0.8 mm
Copper Ratio	Outer Layer (First Layer): Less than 95% of 50 mm Square Inner Layers (Second and Third Layers): Approx. 100% of 50 mm Square Outer Layer (Fourth Layer): Approx. 100% of 50 mm Square
Through-holes	φ 0.3 mm × 21 pcs

Measurement Result

(Ta = 25°C, Tjmax = 150°C)

Item	Measurement Result
Power Dissipation	3600 mW
Thermal Resistance (θja)	θja = 34.5°C/W
Thermal Characterization Parameter (ψjt)	ψjt = 10°C/W

θja: Junction-to-Ambient Thermal Resistance

ψjt: Junction-to-Top Thermal Characterization Parameter

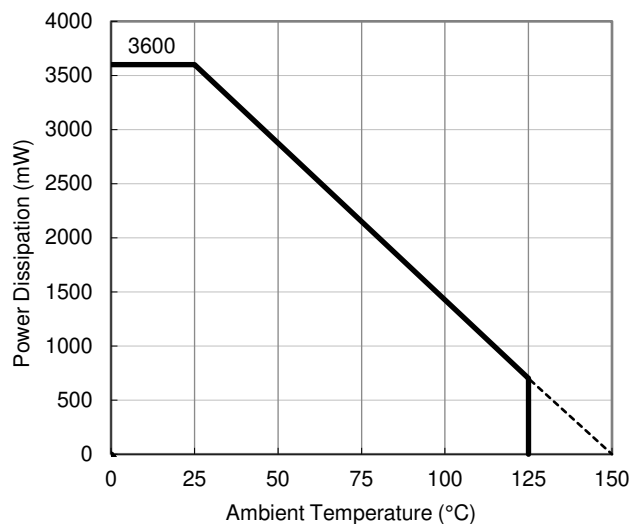

Power Dissipation vs. Ambient Temperature

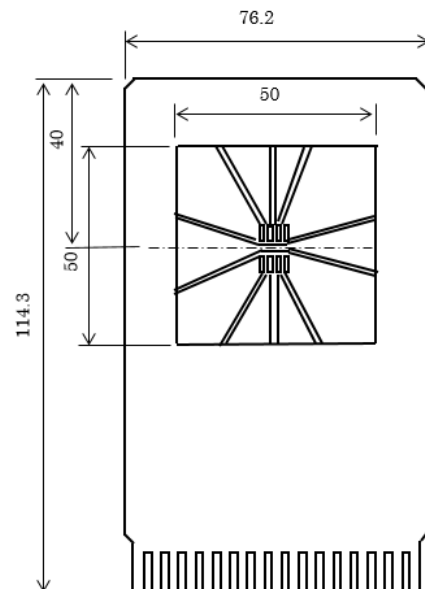

Measurement Board Pattern

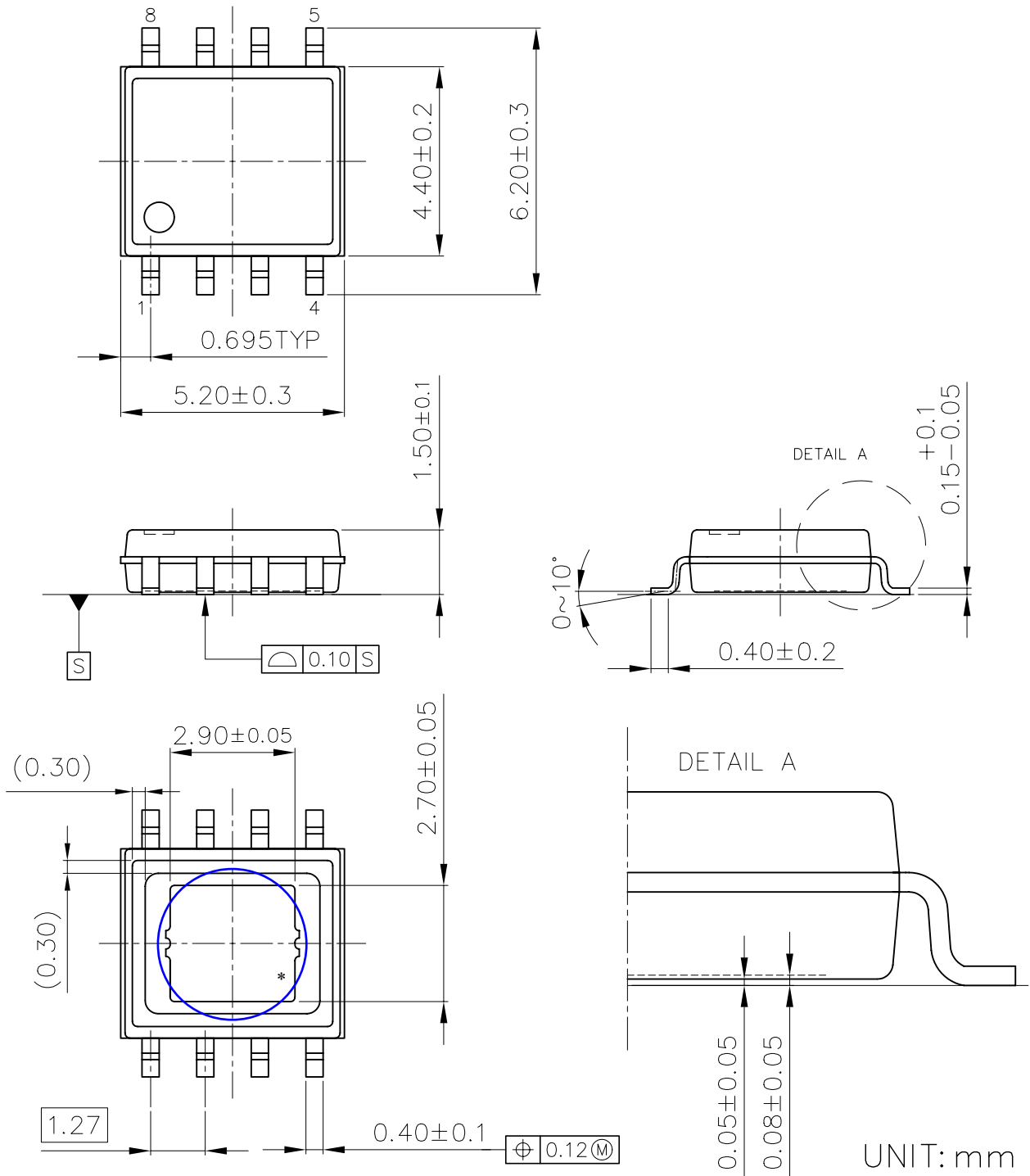

HSOP-8E Package Dimensions

* The tab on the bottom of the package shown by blue circle is substrate potential (GND). It is recommended that this tab be connected to the ground plane on the board but it is possible to leave the tab floating.



1. The products and the product specifications described in this document are subject to change or discontinuation of production without notice for reasons such as improvement. Therefore, before deciding to use the products, please refer to our sales representatives for the latest information thereon.
2. The materials in this document may not be copied or otherwise reproduced in whole or in part without prior written consent of our company.
3. Please be sure to take any necessary formalities under relevant laws or regulations before exporting or otherwise taking out of your country the products or the technical information described herein.
4. The technical information described in this document shows typical characteristics of and example application circuits for the products. The release of such information is not to be construed as a warranty of or a grant of license under our company's or any third party's intellectual property rights or any other rights.
5. The products in this document are designed for automotive applications. However, when using the products for automotive applications, please make sure to contact our sales representative in advance due to confirming the quality level.
6. We are making our continuous effort to improve the quality and reliability of our products, but semiconductor products are likely to fail with certain probability. In order to prevent any injury to persons or damages to property resulting from such failure, customers should be careful enough to incorporate safety measures in their design, such as redundancy feature, fire containment feature and fail-safe feature. We do not assume any liability or responsibility for any loss or damage arising from misuse or inappropriate use of the products.
7. Anti-radiation design is not implemented in the products described in this document.
8. The X-ray exposure can influence functions and characteristics of the products. Confirm the product functions and characteristics in the evaluation stage.
9. WLCSP products should be used in light shielded environments. The light exposure can influence functions and characteristics of the products under operation or storage.
10. There can be variation in the marking when different AOI (Automated Optical Inspection) equipment is used. In the case of recognizing the marking characteristic with AOI, please contact our sales or our distributor before attempting to use AOI.
11. Please contact our sales representatives should you have any questions or comments concerning the products or the technical information.



Nisshinbo Micro Devices Inc.

Official website

<https://www.nisshinbo-microdevices.co.jp/en/>

Purchase information

<https://www.nisshinbo-microdevices.co.jp/en/buy/>

