

THIS DRAWING IS A CONTROLLED DOCUMENT FOR SOURIAU USA, INC. IT IS SUBJECT TO CHANGE WITHOUT NOTIFICATION. CONTACT THE DOCUMENT CONTROL CENTER FOR THE LATEST REVISION.

DWG. NO. **JBXHH2C**

MASS (g)	VOLUME (mm ³)
16.6	3159

ELECTRICAL:

EMI SHIELDING : SHIELDED FOR THE RANGE 55dB UP TO 100MHZ

INSULATION RESISTANCE : >500MΩ PER ANSI-EIA-364-D METHOD 21

MAX. CURRENT RATING : SEE INSULATOR DRAWING

CONNECTOR TESTING VOLTAGE : SEE INSULATOR DRAWING

CONNECTOR WORKING VOLTAGE : SEE INSULATOR DRAWING

ENVIRONMENTAL:

ENDURANCE: 1000 CYCLES AS PER MIL-STD 1344A, METHOD 2016.1

SHOCK: 50 g . DURATION 6 ms; AS PER MIL-STD 1344A, METHOD 2004.1

VIBRATIONS: 10 TO 2000Hz g = 15g, AS PER MIL-STD 1344A, METHOD 2005.1

PROTECTION INDEX: IP 67 AS PER CEI 529

ROHS COMPLIANT

SALT MIST : 48Hr PER SAE AS 1344 METHOD 1001.1 CEI 529

OPERATING TEMPERATURE: -40°C TO +80°C (-40°F TO +176°F)

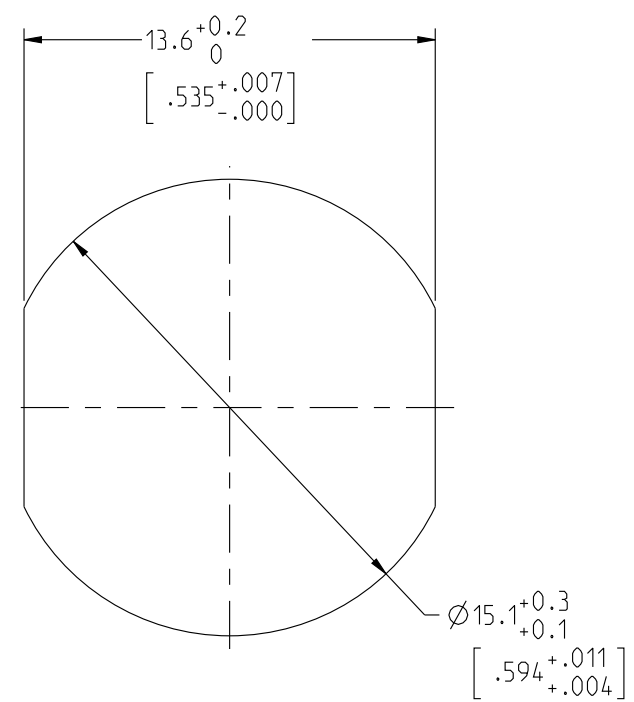

NOTES:

1 RED BAND

MATERIAL:

OUTER SHELL : } BRASS
SHIELD RING & NUT: }

FINISH:

OUTER SHELL: CHROME
OTHER BRASS PARTS : NICKEL

TOOLS

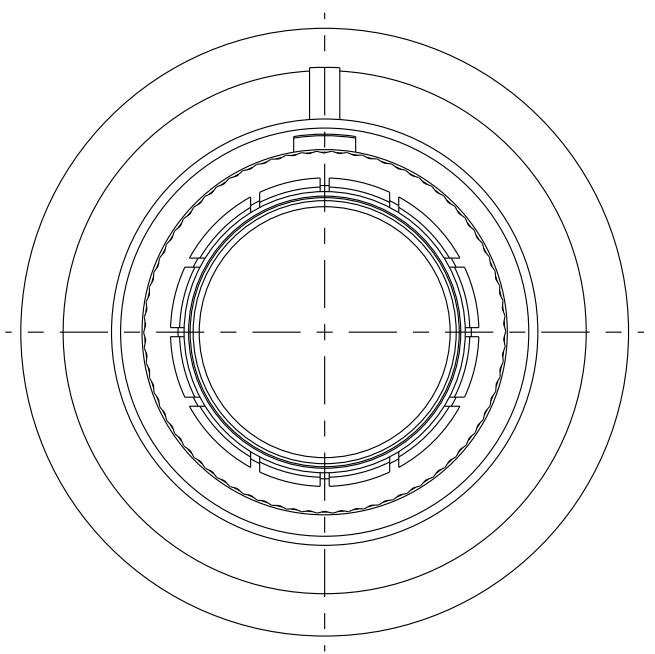

MATING SIDE VIEW

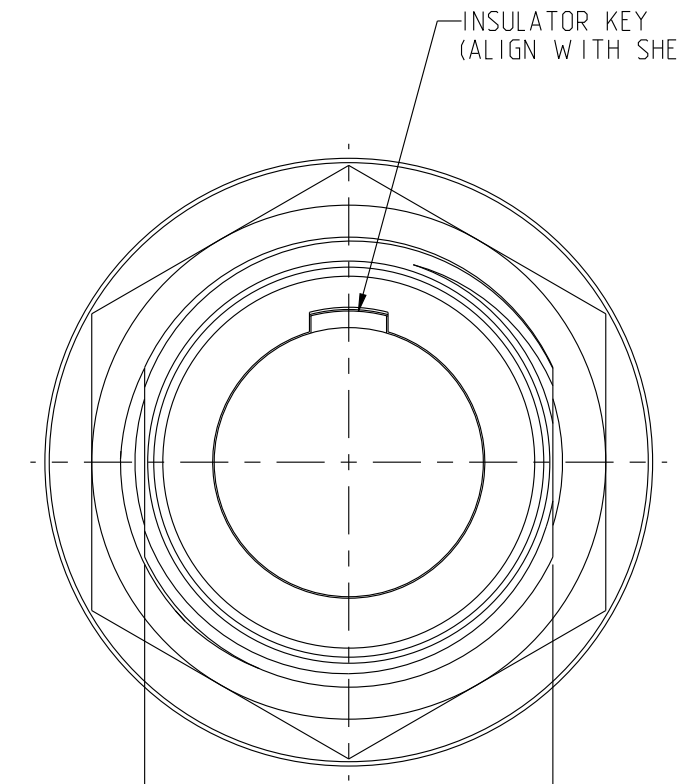
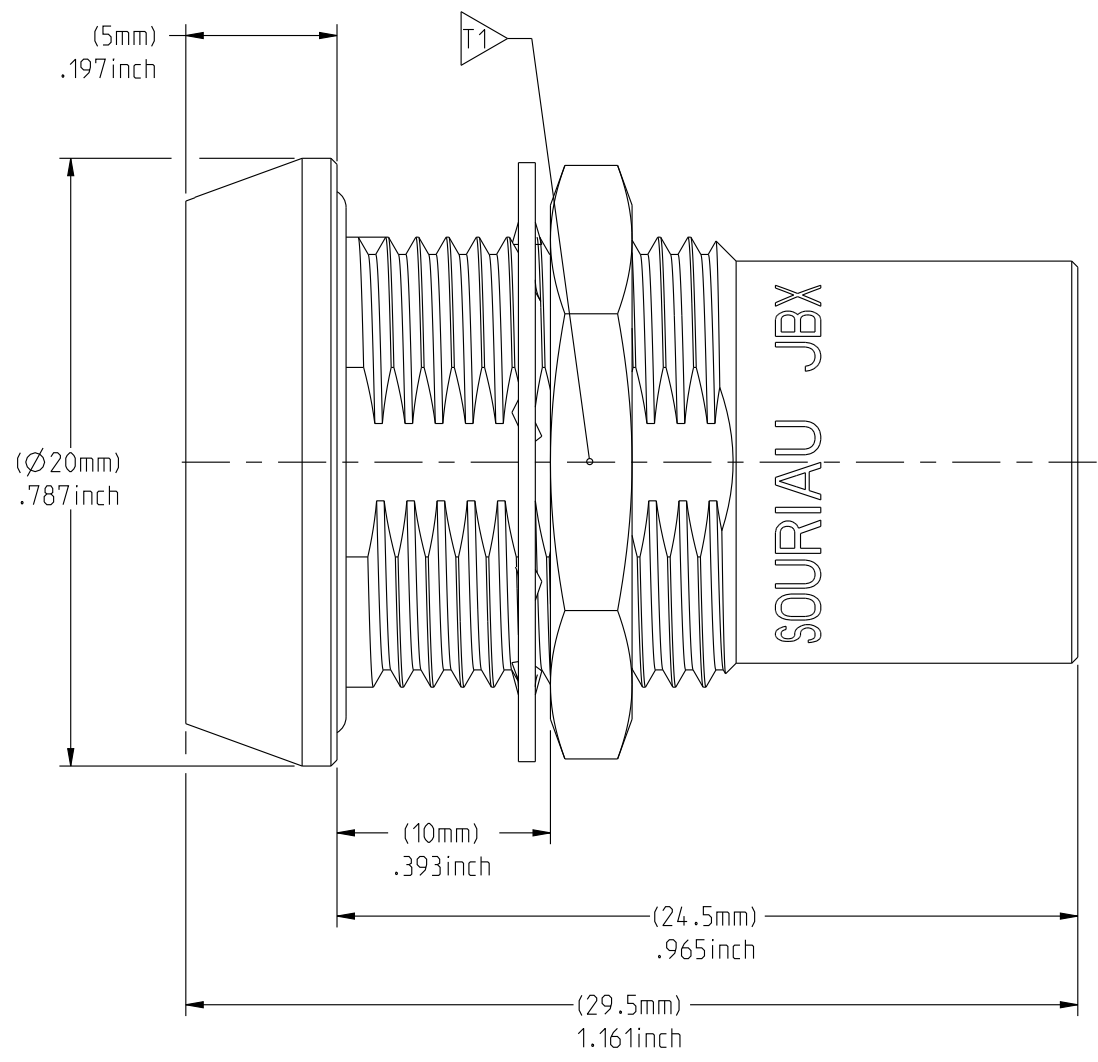

WIRE SIDE VIEW

PART LIST	
ITEM NO.	DESCRIPTION
1	SHELL
2	HEX NUT
3	LOCK WASHER

	TOOLS (JAW DIMENSION)	ADVISED TORQUE IN Nm
	17	1.7

CATALOG NUMBER DESCRIPTION

JBX HH 2 XXXXX DSR

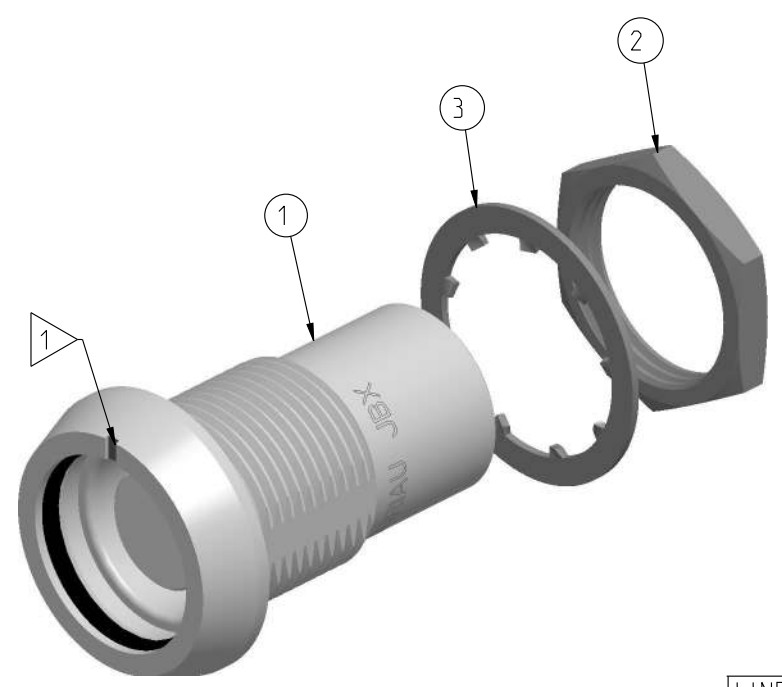
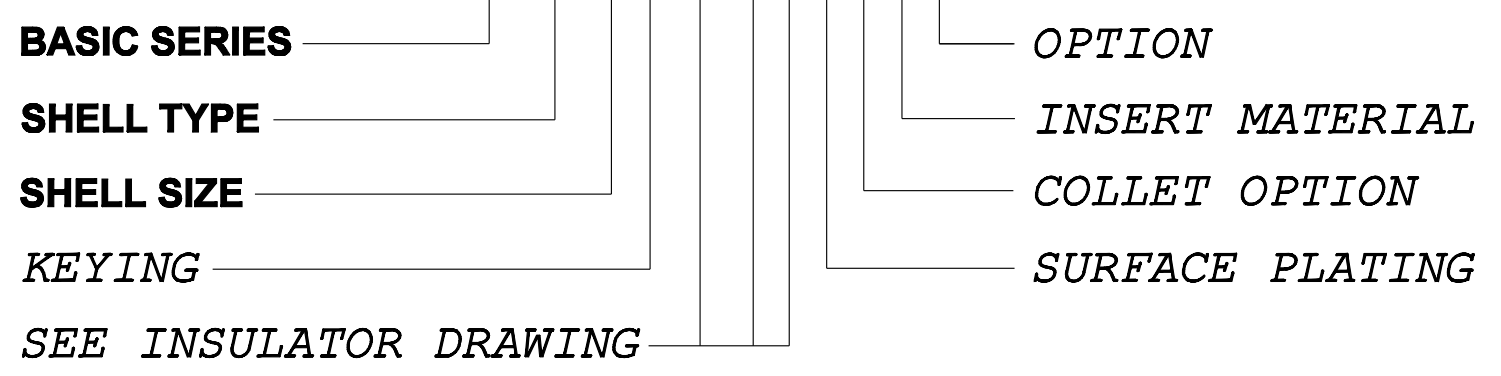

SCALE 2:1

ORIGIN	COUNTRY	JURISDICTION	CLASSIFICATION
X	FR	Not listed	N/A
	US	EAR	ECCN =EAR99

These commodities, technology or software are exported from the United States in accordance with the Export Administration Regulations. Diversion contrary to U.S. law is prohibited.

LINEAR MEASURE: $\frac{mm}{INCH}$ mm (INCH)

THIRD ANGLE PROJECTION

TOLERANCES UNLESS OTHERWISE SPECIFIED

No. OF PLACES	mm [INCH]
WHOLE No.	±0.5 [±.02]
ONE PLACE	±0.2 [±.008]
TWO PLACES	±0.1 [±.004]

ANGLES ±1°

DRAWING TITLE
JBX, SIZE 2, SEALED FRONT PANEL MOUNTING RECEPTACLE

CAT NO. **JBXHH2**

CAGE NO: 09922 SIZE: C

CUSTOMER

INTERPRET THIS DRAWING IN ACCORDANCE WITH ASME Y14.5M - 1994.

SOURIAU
www.souriau.com

APPROVAL	DRAWN: SKV	01-21-15
	CHKD : EV	01-21-15
	DSGN : EV	01-21-15
	MFG : DH	01-21-15
	QC : BB	01-21-15
	DRAWING SCALE: 4:1	
	DRAWING NO.	REV
	JBXHH2C	A

1 OF 1

THE INFORMATION CONTAINED IN THIS DRAWING IS CONFIDENTIAL AND MAY NOT BE DISCLOSED WITHOUT WRITTEN CONSENT FROM SOURIAU USA, INC.

DWG. NO.
JBX2INSMCC

MALE INSULATOR, CRIMP CONTACT

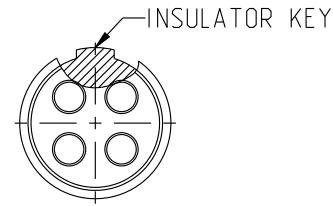
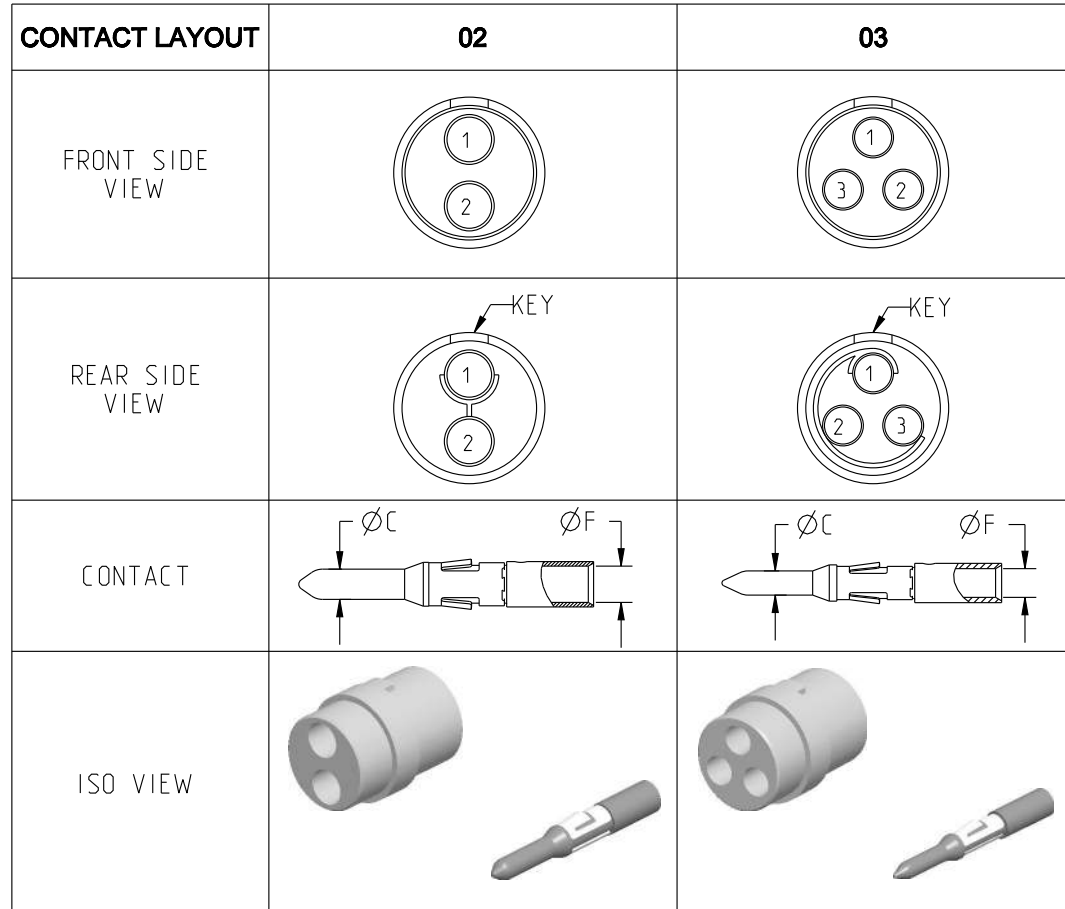

CONTACT TYPE : M (MALE)
CONTACT TERMINATION : C (CRIMP)
MATERIAL :
 CONTACT: BRASS
 CLIP: COPPER ALLOY
 INSULATOR: PEEK
FINISH :
 CONTACTS: GOLD

CATALOG NUMBER DESCRIPTION

JBXXX 2 XYYM CXXXX

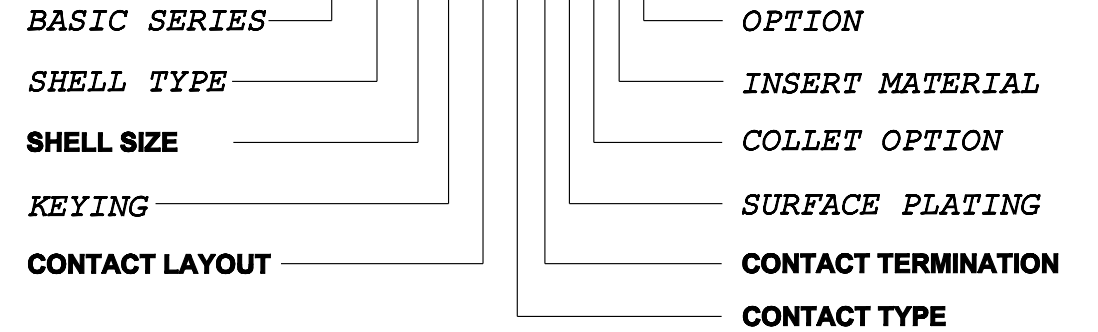

	02	03
CONTACT		
ØC	2	1.6
ØF	2.4	1.9
MAX. AWG	12	14
MAX. CURRENT RATING (A)	30	17
CONTACT RESISTANCE (mΩ)	2.5	2.5
INSULATOR		
NUMBER OF CAVITY	2	3
MAX. CURRENT RATING	30	17
TEST VOLTAGE (Vrms)	2100	1700
WORKING VOLTAGE (Vdc/Vrms)	1000/700	830/560

B	REVISED PER ECN 12286	RSK 06-10-15	EV 06-10-15
A	RELEASED PER ECN 12264	SKV 03-10-15	EV 03-10-15
REV	DESCRIPTION	BY DATE	CHKD DATE

THIS DRAWING IS A CONTROLLED DOCUMENT FOR SOURIAU USA, INC. IT IS SUBJECT TO CHANGE WITHOUT NOTIFICATION. CONTACT THE DOCUMENT CONTROL CENTER FOR THE LATEST REVISION.

THE INFORMATION CONTAINED IN THIS DRAWING IS CONFIDENTIAL AND MAY NOT BE DISCLOSED WITHOUT WRITTEN CONSENT FROM SOURIAU USA, INC.

B

A

LINEAR MEASURE: $\frac{mm}{INCH}$ mm (INCH)

THIRD ANGLE PROJECTION

TOLERANCES UNLESS OTHERWISE SPECIFIED

No. OF PLACES	mm [INCH]
ONE PLACE	±3 [±.1]
TWO PLACES	±0.5 [±.02]
THREE PLACES	±0.25 [±.010]

ANGLES ±1°

ORIGIN	COUNTRY	JURISDICTION	CLASSIFICATION
X	FR	Not listed	N/A
	US	EAR	ECCN =EAR99

These commodities, technology or software are exported from the United States in accordance with the Export Administration Regulations. Diversion contrary to U.S. law is prohibited

DRAWING TITLE
JBX, SIZE 2, MALE INSULATOR, CRIMP CONTACT

CAT NO. **JBX2INSMC**

CAGE NO: 09922 SIZE: B

CUSTOMER

SOURIAU

WWW.SOURIAU.COM

INTERPRET THIS DRAWING IN ACCORDANCE WITH ASME Y14.5M - 1994.

APPROVAL	DRAWN: SKV	02-02-15
	CHKD : EV	02-02-15
	DSGN : EV	02-02-15
	MFG : DH	02-02-15
	QC : BB	02-02-15
	DRAWING SCALE: NA	
	DRAWING NO.	REV
	JBX2INSMCC	B
	1 OF 3	

THIS DRAWING IS A CONTROLLED DOCUMENT FOR SOURIAU USA, INC. IT IS SUBJECT TO CHANGE WITHOUT NOTIFICATION. CONTACT THE DOCUMENT CONTROL CENTER FOR THE LATEST REVISION.

THE INFORMATION CONTAINED IN THIS DRAWING IS CONFIDENTIAL AND MAY NOT BE DISCLOSED WITHOUT WRITTEN CONSENT FROM SOURIAU USA, INC.

DWG. NO.
JBX2INSMCC

	2				1		
CONTACT LAYOUT	04	05	06	07	08	10	
FRONT SIDE VIEW							
REAR SIDE VIEW							
CONTACT							
ISO VIEW							
CONTACT	ØC	1.3	1.3	1.3	0.9	0.9	
	ØF	1.4	1.4	1.4	1.1	1.1	
	MAX. AWG	18	18	18	20	20	
	MAX. CURRENT RATING (A)	15	15	15	10	10	
INSULATOR	CONTACT RESISTANCE (mΩ)	3	3	3	3.5	3.5	
	NUMBER OF CAVITY	4	5	6	7	10	
	MAX. CURRENT RATING	15	14	12	11	8	
	TEST VOLTAGE (Vrms)	2400	1900	1900	1500	1700	
WORKING VOLTAGE (Vdc/Vrms)	1000/700	900/630	900/630	730/500	830/560	830/560	

ORIGIN	COUNTRY	JURISDICTION	CLASSIFICATION
X	FR	Not listed	N/A
	US	EAR	ECCN =EAR99

These commodities, technology or software are exported from the United States in accordance with the Export Administration Regulations. Diversion contrary to U.S. law is prohibited.

LINEAR MEASURE:

THIRD ANGLE PROJECTION

TOLERANCES UNLESS OTHERWISE SPECIFIED

No. OF PLACES	mm [INCH]
ONE PLACE	±3 [±.1]
TWO PLACES	±0.5 [±.02]
THREE PLACES	±0.25 [±.010]

ANGLES ±1°

DRAWING TITLE
JBX, SIZE 2, MALE INSULATOR, CRIMP CONTACT

CAT NO. **JBX2INSMC**

CAGE NO: 09922 SIZE: B

CUSTOMER

SOURIAU

WWW.SOURIAU.COM

INTERPRET THIS DRAWING IN ACCORDANCE WITH ASME Y14.5M - 1994.

APPROVAL	DRAWN: SKV	02-02-15
	CHKD : EV	02-02-15
	DSGN : EV	02-02-15
	MFG : DH	02-02-15
	QC : BB	02-02-15
	DRAWING SCALE: NA	
	DRAWING NO.	REV
	JBX2INSMCC	B
	2 OF 3	

2

1

PRO-E

B

A

DWG. NO.
JBX2INSMCC

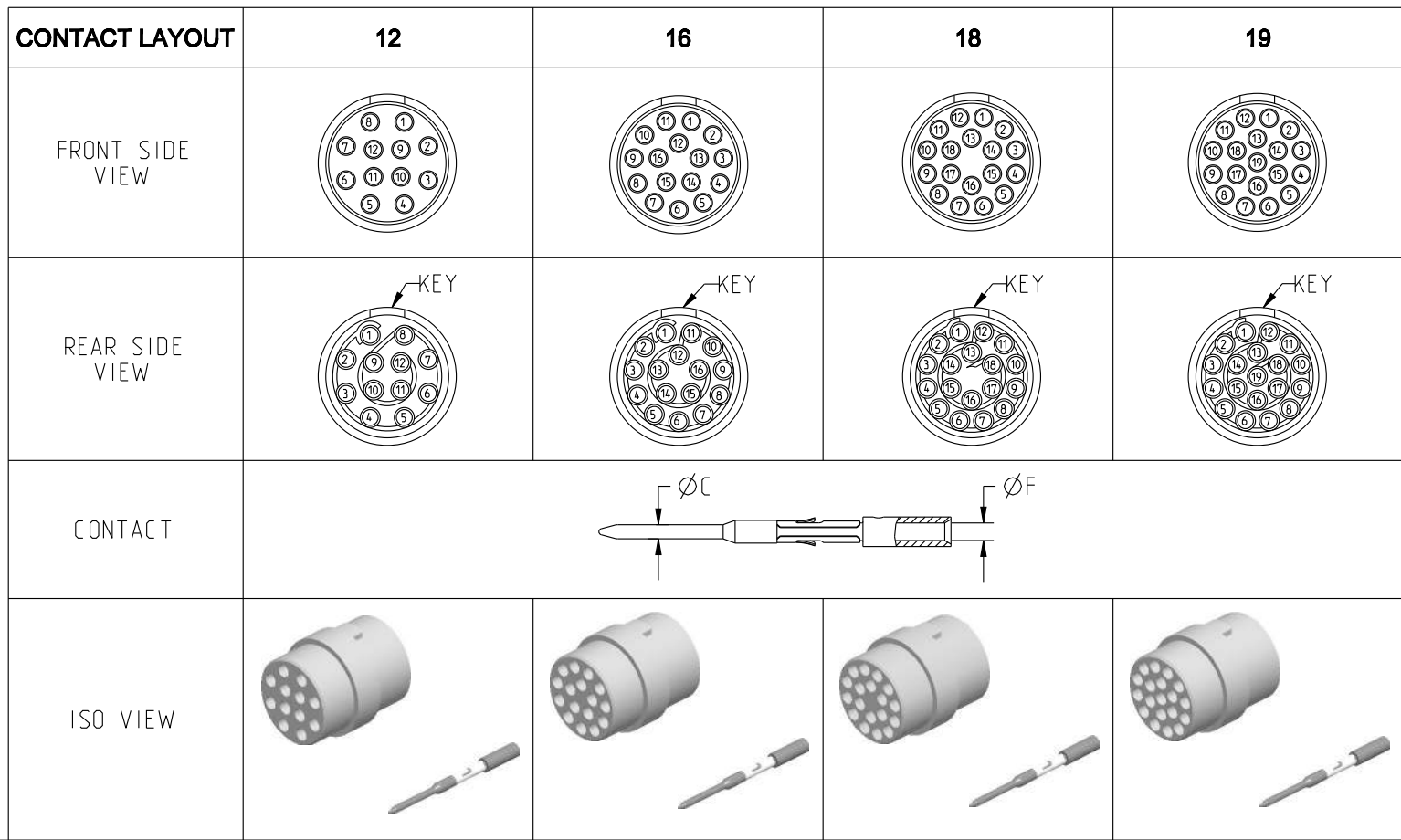

CONTACT	ØC	0.7	0.7	0.7	0.7
	ØF	0.85	0.85	0.85	0.85
	MAX. AWG	22	22	22	22
	MAX. CURRENT RATING (A)	7	7	7	7
INSULATOR	CONTACT RESISTANCE (mΩ)	5	5	5	5
	NUMBER OF CAVITY	12	16	18	19
	MAX. CURRENT RATING	7	6	5.5	5
	TEST VOLTAGE (Vrms)	1700	1500	1400	1400
	WORKING VOLTAGE (Vdc/Vrms)	830/560	730/500	660/460	660/460

THIS DRAWING IS A CONTROLLED DOCUMENT FOR SOURIAU USA, INC. IT IS SUBJECT TO CHANGE WITHOUT NOTIFICATION. CONTACT THE DOCUMENT CONTROL CENTER FOR THE LATEST REVISION.

THE INFORMATION CONTAINED IN THIS DRAWING IS CONFIDENTIAL AND MAY NOT BE DISCLOSED WITHOUT WRITTEN CONSENT FROM SOURIAU USA, INC.

B

A

DRAWING TITLE		JBX, SIZE 2, MALE INSULATOR, CRIMP CONTACT	
CAT NO.		JBX2INSMC	
CAGE NO: 09922	SIZE: B	CUSTOMER	SOURIAU
INTERPRET THIS DRAWING IN ACCORDANCE WITH ASME Y14.5M - 1994.			
APPROVAL	DRAWN: SKV 02-02-15	DRAWING SCALE: NA	
	CHKD : EV 02-02-15	DRAWING NO. REV	
	DSGN : EV 02-02-15	JBX2INSMCC B	
	MFG : DH 02-02-15	3 OF 3	
	QC : BB 02-02-15	PRO-E	

LINEAR MEASURE: $\frac{mm}{INCH}$ mm (INCH)

THIRD ANGLE PROJECTION

TOLERANCES UNLESS OTHERWISE SPECIFIED

No. OF PLACES	mm [INCH]
ONE PLACE	±3 [±.1]
TWO PLACES	±0.5 [±.02]
THREE PLACES	±0.25 [±.010]

ANGLES ±1°

ORIGIN	COUNTRY	JURISDICTION	CLASSIFICATION
X	FR	Not listed	N/A
	US	EAR	ECCN =EAR99

These commodities, technology or software are exported from the United States in accordance with the Export Administration Regulations. Diversion contrary to U.S. law is prohibited