

Evaluating the **AD7294-2** 12-Bit Monitor and Control System

FEATURES

Full featured evaluation board for the **AD7294-2**
Various link options
PC control in conjunction with evaluation software
System demonstration platform (SDP) compatible
PC software for control of **AD7294-2**
Serial interface SPI®-/QSPI™-/DSP-compatible

EVALUATION KIT CONTENTS

AD7294-2SDZ evaluation board (**EVAL-AD7294-2SDZ**)
Evaluation software CD
USB cable

ADDITIONAL EQUIPMENT NEEDED

EVAL-SDP-CB1Z (must order separately)
includes a USB cable
PC running Windows XP, Windows Vista, or Windows 7 with
USB 2.0 port

GENERAL DESCRIPTION

This user guide describes the evaluation board for the **AD7294-2**, a 12-bit monitoring device with multichannel ADC, DACs, current sensors, and temperature sensors.

Full details on the **AD7294-2** are available in the **AD7294-2** data sheet, which is available from Analog Devices, Inc., and should be consulted in conjunction with this user guide when using the evaluation board. Configuration of the various link options is explained in the Evaluation Board Hardware section.

The evaluation board interfaces to the USB port of a PC via the SDP board. Software is available with the evaluation board which allows the user to easily program the **AD7294-2**.

The kit requires purchasing the controller board for the system demonstration platform (**EVAL-SDP-CB1Z**).

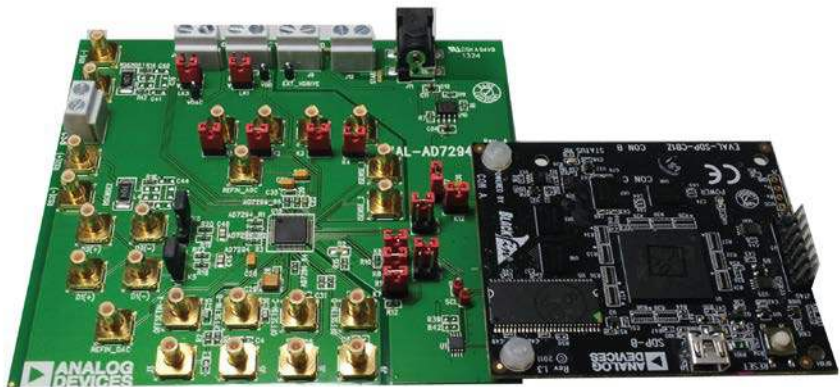

Figure 1. Universal Evaluation Board Connected to the SDP-B Board

TABLE OF CONTENTS

Features	1	Evaluation Board Software	4
Evaluation Kit Contents.....	1	Warning	4
Additional Equipment Needed	1	Installing the Software	4
General Description	1	Running the Software	4
Revision History	2	Software Operation	5
Evaluation Board Hardware	3	Evaluation Board Schematics and Artwork	6
Power Supplies	3	Ordering Information	10
Link Options	3	Components List	10

REVISION HISTORY

12/13—Revision 0: Initial Version

EVALUATION BOARD HARDWARE

POWER SUPPLIES

When using the evaluation board with the SDP board, the V_{DRIVE} supply is supplied from the SDP board. A 9 V supply should be applied to J11 or a 9 V supply should be applied between PWR and AGND or DGND.

Both AGND and DGND inputs are provided on the board. The AGND and DGND planes are connected on the board. However, it is not recommended to connect AGND and DGND elsewhere in the system to avoid ground loop problems.

All supplies are decoupled to ground with 10 μ F tantalum and 0.1 μ F ceramic capacitors.

Table 1. Power Supply Connectors

Connector No.	Voltage
J1	Analog positive supply and ground for the main device, AVDD and AGND.
J10	DAC power supply, DACVDD.
J8	Digital drive voltage supply.
J11 or J12	Board positive supply and ground. For single-supply operation, supply 9 V between PWR and GND.

LINK OPTIONS

A number of link and switch options are incorporated in the evaluation board and should be set for the required operating setup before using the board. The functions of these link options are described in detail in Table 3. Table 2 describes the positions of the different links to control the evaluation board by PC, via the USB port and the SDP board using the [AD7294-2](#) evaluation board.

Table 2. Link Options Setup for SDP Control (Default)

Link No.	Options
LK1	A
LK2	B
LK3	A
LK4	B
K1 to K4	Not inserted
K7 to K9	Inserted
K12	Inserted
K14	Inserted

Table 3. Link Functions

Link No.	Option
LK1	LK1 selects the AVDD power supply source for the analog circuitry. Position A selects J1 as the AVDD analog circuitry power supply source. Position B selects the ADP7104 + 5 V as the AVDD analog circuitry power supply source.
LK2	LK2 selects the voltage power supply source for the drive voltage for digital circuitry. Position A selects J8 as the drive voltage. Position B selects the 3.3 V from the SDP board as the drive voltage.
LK3	LK3 selects the voltage power supply source for DAC voltage supplies. Position A selects J10 as the DAC power supply source. Position B selects the ADP7104 + 5 V as the AVDD analog circuitry power supply source.
LK4	LK4 selects the high voltage level option for the address pin options for the evaluation board. Position A selects AVDD (LK1) as the high voltage level. Position B selects 3.3 V from the SDP board as the high voltage level.
K1 to K4	K1 to K4 allow the user to connect the ADC inputs VIN0 to VIN3 to GND.
K7 to K9	K7 to K9 allow the user to connect the address pins AS0 to AS2 to GND. K9 connects AS0 to GND. K8 connects AS1 to GND. K7 connects AS2 to GND.
K12	K12 connects the 3.3 V option from the SDP board to the evaluation board.
K14	K14 connects the evaluation power supply to power the SDP board. The SDP board may not work correctly if K14 is not inserted.

EVALUATION BOARD SOFTWARE

Each kit includes a CD containing software to be installed on the PC before the evaluation board is used.

The software is compatible with Windows® XP, Windows Vista, and Windows 7.

WARNING

Install the software before connecting the SDP board to the USB port of the PC. This ensures that the SDP board is recognized when it connects to the PC.

INSTALLING THE SOFTWARE

1. Start the Windows operating system and insert the CD.
2. Check that the installation software automatically opens. If it does not, then run the **setup.exe** file from the CD.
3. After installation is completed, power up the evaluation board as described in the Power Supplies section.
4. Plug the [EVAL-AD7294-2SDZ](#) into the SDP board and the SDP board into the PC using the USB cable included in the evaluation kit.
5. When the software detects the evaluation board, proceed through any dialog boxes that appear to finalize the installation.

RUNNING THE SOFTWARE

To run the program, do the following:

1. Click **Start>All Programs>Analog Devices>AD7294-2>AD7294-2 Evaluation Software**.
To uninstall the program if necessary, click **Start>Control Panel>Add or Remove Programs>AD7294-2 Evaluation Software**.
2. If the SDP board is not connected to the USB port when the software is launched, a connectivity error is displayed (see Figure 2). Simply connect the evaluation board to the USB port of the PC, wait a few seconds, click **Rescan**, and follow the instructions.

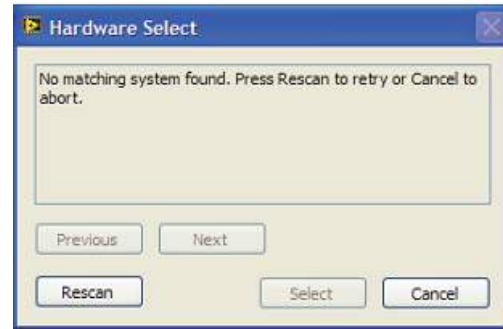

Figure 2. Pop-Up Window Error

3. If the SDP board is not connected to the evaluation boards, a message box appears as shown in Figure 3. Check the connection between the SDP and the [EVAL-AD7294-2SDZ](#) boards and run the program again.



Figure 3. Error Message

4. If the SDP board is connected, the system development platform connects for a brief period as shown in Figure 4.



Figure 4. System Develop Platform Wait Window

The main window of the [AD7294-2](#) evaluation software then opens as shown in Figure 5.

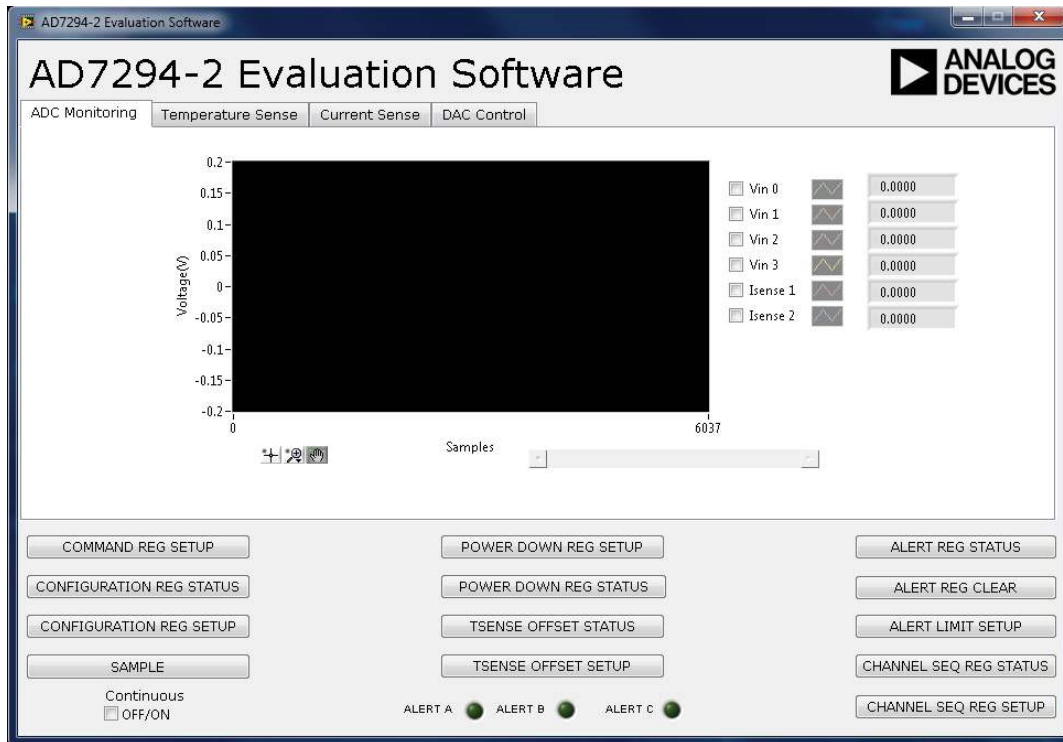

Figure 5. AD7294-2 Evaluation Board Main Window

SOFTWARE OPERATION

The data programmed into each register can be changed by clicking on the relevant buttons.

Tabs

There are four tab options: **ADC Monitoring**, **Temperature Sense**, **Current Sense**, and **DAC Control**.

The first three tabs display the current voltages that are being read back by the ADC which are selected in the command register when in command mode.

The **DAC Control** tab is used to input a DAC code and change VOUTA to VOUTD. Under DAC CODE, type the data in hexadecimal format. To execute, click **Write to Part**.

There are 13 buttons available in the [AD7294-2](#) software at the bottom portion of the window.

Buttons

The status buttons (**CONFIGURATION REG STATUS**, **POWER DOWN REG STATUS**, **TSENSE OFFSET STATUS**, **ALERT REG STATUS**, and **CHANNEL SEQ REG STATUS**) allow you to read the current status of the register. When you click on a status button, a sub-window pops up with the current register read displayed. Click **Exit** to close the sub-window and access the main window.

The set up buttons (**COMMAND REG SETUP**, **CONFIGURATION REG SETUP**, **POWER DOWN REG SETUP**, **TSENSE OFFSET SETUP**, **ALERT LIMIT SETUP**, and **CHANNEL SEQ REG SETUP**) allow you to write to a particular register. When you click on a setup button, a sub-window appears. To set a bit to Logic 1, check the checkbox; to set a bit to Logic 0 leave the checkbox unchecked. To execute, click **Write**.

Refer to the register settings of the [AD7294-2](#) data sheet for details on the functions of each register.

SAMPLE is the button that enables ADC sampling in command mode.

EVALUATION BOARD SCHEMATICS AND ARTWORK

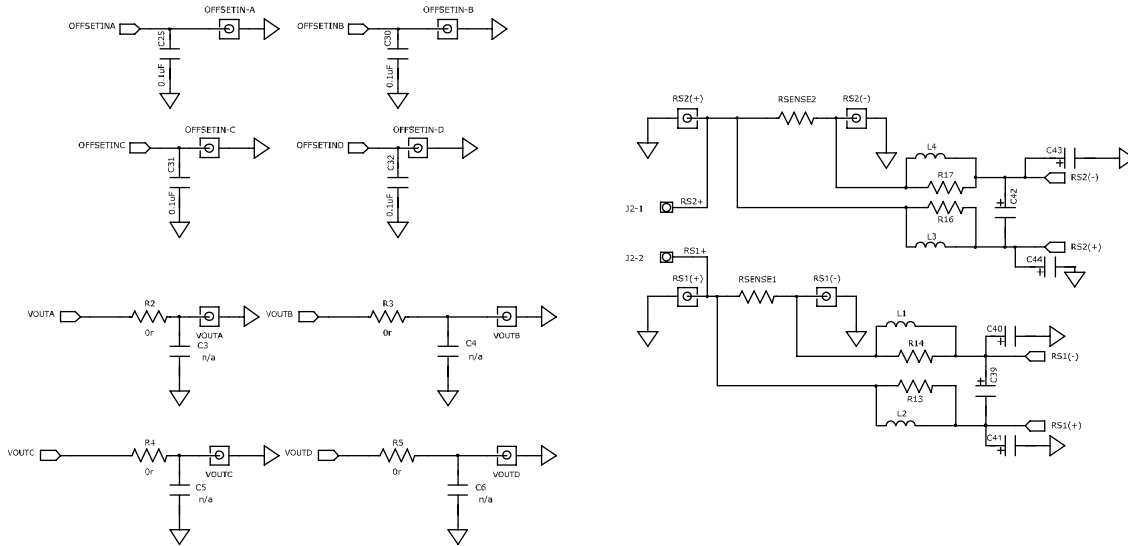

Figure 6. Schematic of AD7294-2 Output Circuitry

11782-006

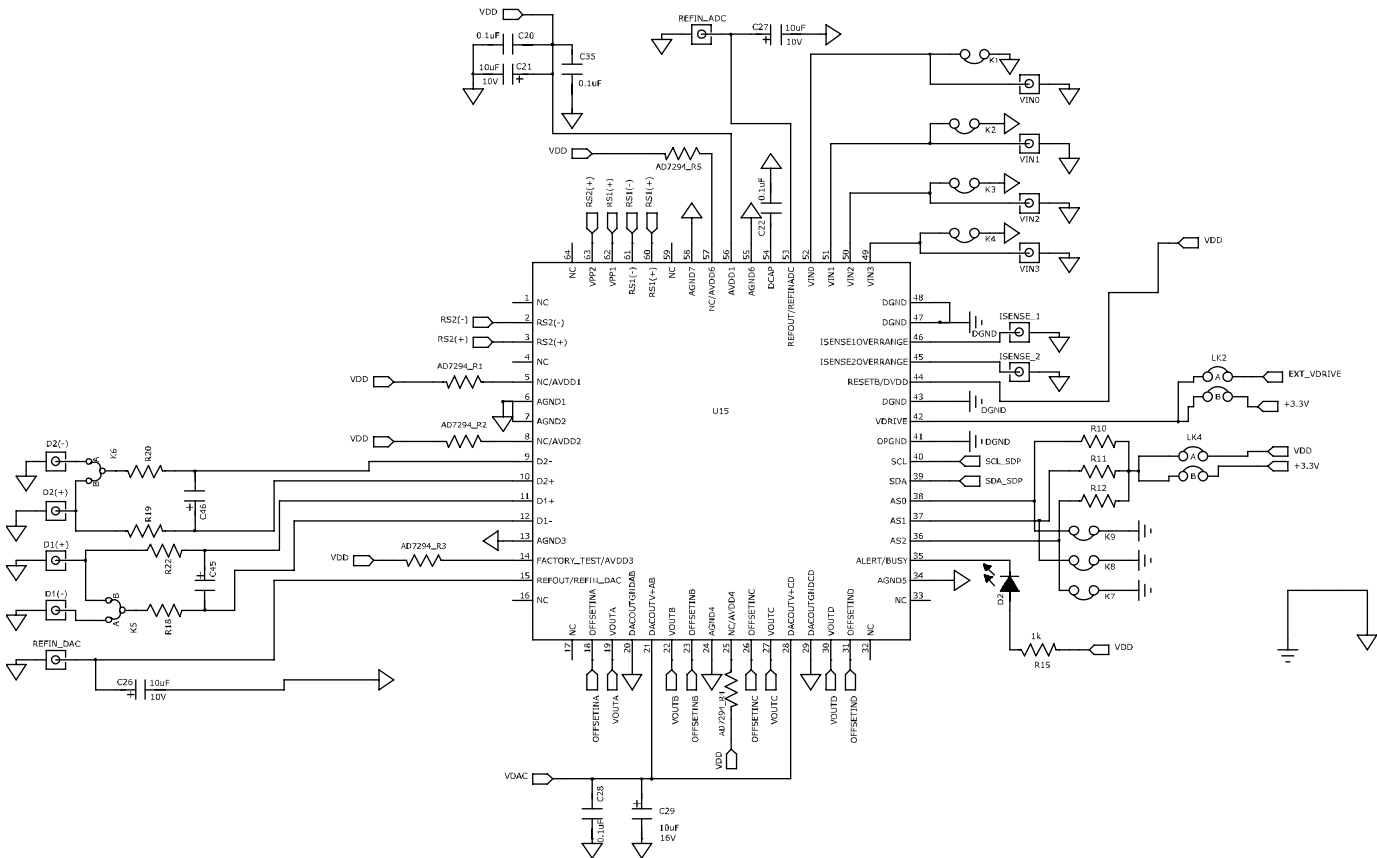

Figure 7. Schematic of AD7294-2 Circuitry

11782-007

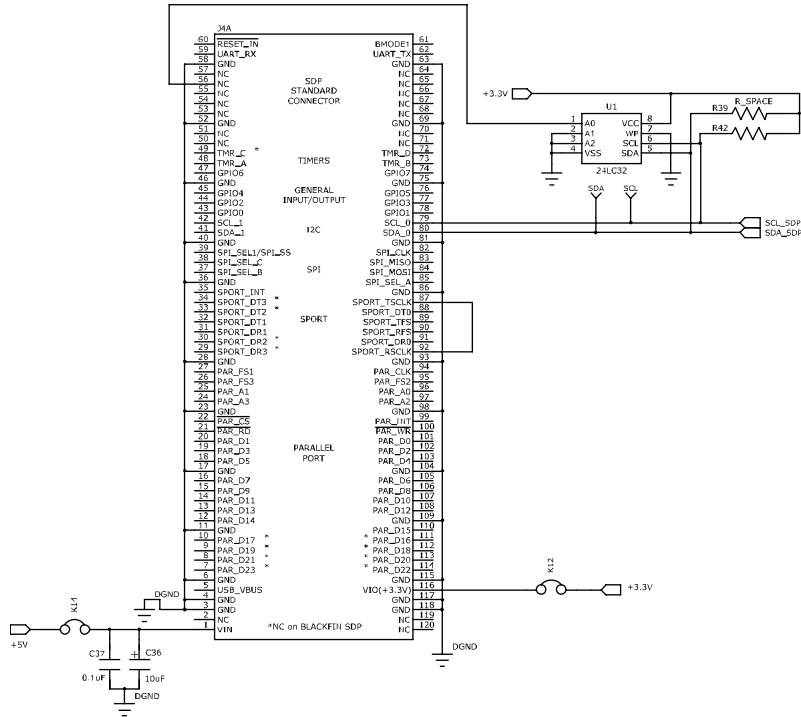

Figure 8. Schematic of SDP Circuitry

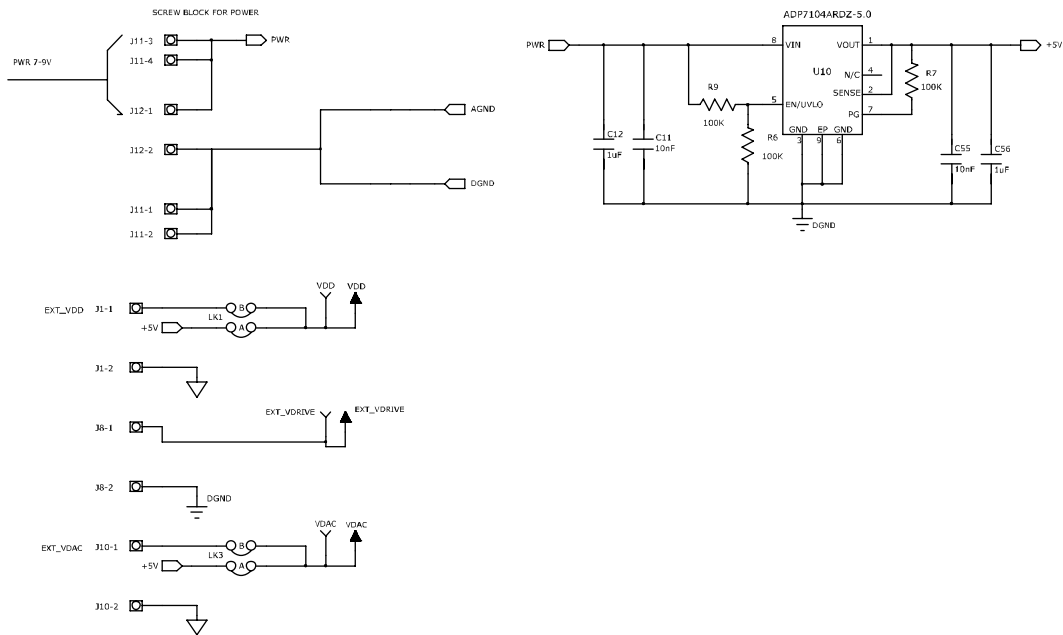

Figure 9. Schematic of AD7294-2 Power Supply Circuitry

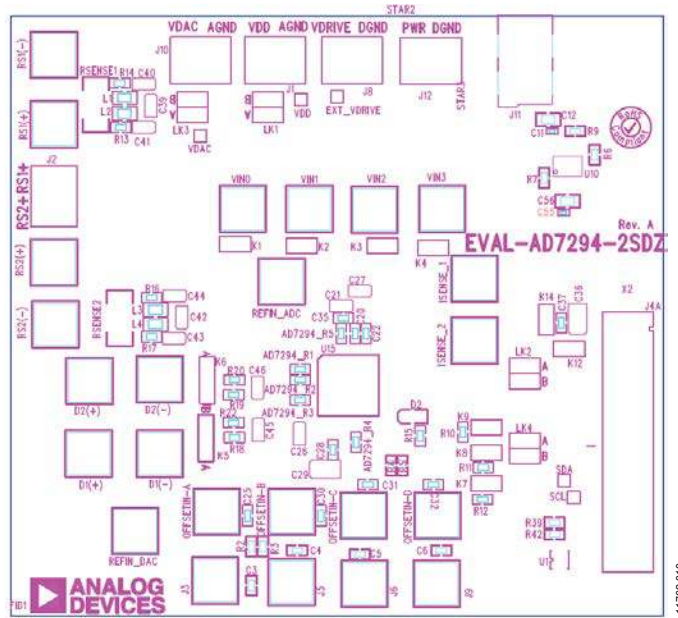

Figure 10. Component Placement Drawing

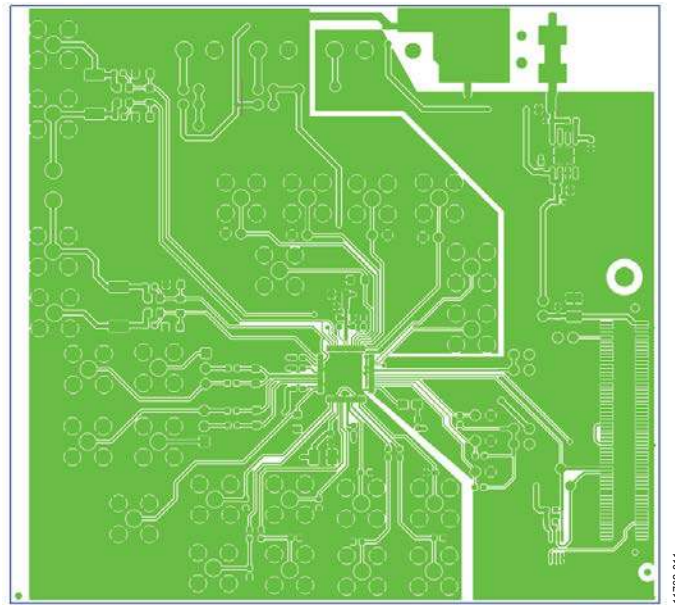

Figure 11. Component Side PCB Drawing

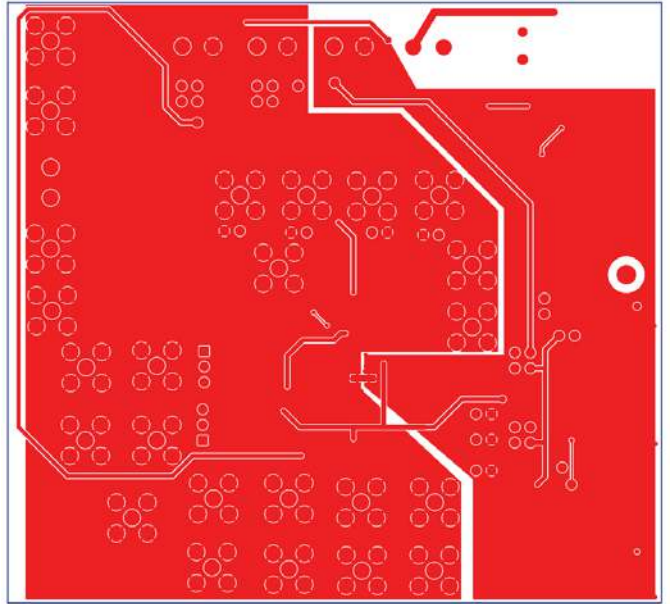

Figure 12. Solder Side PCB Drawing

ORDERING INFORMATION

COMPONENTS LIST

Table 4.

Qty	Reference Designator	Description	Supplier/Part Number
9	R1 to R5, R18, R19, R20, R22	100 Ω resistor	FEC 9330364
2	C1, C2	100 nF capacitor	FEC 8820023
2	C7, C9	4.7 μ F capacitor	FEC 1894509
1	C8	10 nF capacitor	FEC 1833842
1	C10	47 μ F capacitor	FEC 1658411
2	C11, C55	10 nF capacitor	FEC 1758885
2	C12, C56	1 μ F capacitor	FEC 1735541
8	C20, C22, C25, C28, C30, C31, C32, C35	0.1 μ F capacitor	FEC 499-675
1	C37	0.1 μ F capacitor	FEC 432-210
6	C21, C26, C27, C29, C45, C46	10 μ F capacitor	FEC 197-518
1	C36	10 μ F capacitor	FEC 498-737
1	U2	Bidirectional, logic level translator	ADG3304BRUZ
2	U11, U701	50 mA, high voltage, micropower linear regulator, 3.3 V	ADP1720ARMZ-3.3-R7
1	U10	Linear regulator 5 V, 20 V, 500 mA, ultralow noise	ADP7104ARDZ-5.0-R7
4	LK1, LK3, K12, K14	Jumper block	FEC 1022233 and FEC 150411
2	K5, K6	Jumper block	FEC 1022248 and FEC 150410
1	D2	LED	FEC 105-8373
20	D1(+), D1(-), D2(+), D2(-), ISENSE_1, ISENSE_2 OFFSETIN-A, OFFSETIN-B, OFFSETIN-C, OFFSETIN-D, REFIN_ADC, REFIN_DAC, RS1(+), RS1(-), RS2(+), RS2(-), VIN0 to VIN3	PCB BNC jack (square)	FEC 1111349
1	J12	Two-way terminal block	FEC1177875
4	VOUTA to VOUTD	PCB SMB jack	FEC 1206013
1	J4A	120-way connector, 0.6 mm pitch	FEC 1324660
4	J1, J2, J8, J10	2 -pin terminal block, 5 mm pitch	FEC 151789
7	K1 to K4, K7 to K9		FEC 511-705
1	EXT_VDRIVE, VDAC, VDD	Test point	FEC 8731128
5	R10 to R12, RSENSE1, RSENSE2,	100 k resistor	FEC 911471
3	R6, R7, R9	100 k resistor	FEC 9330402
10	R2, R3, R4, R5, R13, R14, R16, R17, R39, R42	0 Ω resistor	FEC 9331662
1	U1	32 K I ² C serial EEPROM	FEC1331330
1	J11	DC power connectors 2 mm SMT power jack	MOUSER 806-KLDX- SMT20202A
4	L1, L2, L3, L4	SMD power inductor	RS 484-1243
1	U15	12-bit monitoring device with multichannel ADC	AD7294-2

NOTES

NOTES

**ESD Caution**

ESD (electrostatic discharge) sensitive device. Charged devices and circuit boards can discharge without detection. Although this product features patented or proprietary protection circuitry, damage may occur on devices subjected to high energy ESD. Therefore, proper ESD precautions should be taken to avoid performance degradation or loss of functionality.

Legal Terms and Conditions

By using the evaluation board discussed herein (together with any tools, components documentation or support materials, the "Evaluation Board"), you are agreeing to be bound by the terms and conditions set forth below ("Agreement") unless you have purchased the Evaluation Board, in which case the Analog Devices Standard Terms and Conditions of Sale shall govern. Do not use the Evaluation Board until you have read and agreed to the Agreement. Your use of the Evaluation Board shall signify your acceptance of the Agreement. This Agreement is made by and between you ("Customer") and Analog Devices, Inc. ("ADI"), with its principal place of business at One Technology Way, Norwood, MA 02062, USA. Subject to the terms and conditions of the Agreement, ADI hereby grants to Customer a free, limited, personal, temporary, non-exclusive, non-sublicensable, non-transferable license to use the Evaluation Board FOR EVALUATION PURPOSES ONLY. Customer understands and agrees that the Evaluation Board is provided for the sole and exclusive purpose referenced above, and agrees not to use the Evaluation Board for any other purpose. Furthermore, the license granted is expressly made subject to the following additional limitations: Customer shall not (i) rent, lease, display, sell, transfer, assign, sublicense, or distribute the Evaluation Board; and (ii) permit any Third Party to access the Evaluation Board. As used herein, the term "Third Party" includes any entity other than ADI, Customer, their employees, affiliates and in-house consultants. The Evaluation Board is NOT sold to Customer; all rights not expressly granted herein, including ownership of the Evaluation Board, are reserved by ADI. CONFIDENTIALITY. This Agreement and the Evaluation Board shall all be considered the confidential and proprietary information of ADI. Customer may not disclose or transfer any portion of the Evaluation Board to any other party for any reason. Upon discontinuation of use of the Evaluation Board or termination of this Agreement, Customer agrees to promptly return the Evaluation Board to ADI. ADDITIONAL RESTRICTIONS. Customer may not disassemble, decompile or reverse engineer chips on the Evaluation Board. Customer shall inform ADI of any occurred damages or any modifications or alterations it makes to the Evaluation Board, including but not limited to soldering or any other activity that affects the material content of the Evaluation Board. Modifications to the Evaluation Board must comply with applicable law, including but not limited to the RoHS Directive. TERMINATION. ADI may terminate this Agreement at any time upon giving written notice to Customer. Customer agrees to return to ADI the Evaluation Board at that time. LIMITATION OF LIABILITY. THE EVALUATION BOARD PROVIDED HEREUNDER IS PROVIDED "AS IS" AND ADI MAKES NO WARRANTIES OR REPRESENTATIONS OF ANY KIND WITH RESPECT TO IT. ADI SPECIFICALLY DISCLAIMS ANY REPRESENTATIONS, ENDORSEMENTS, GUARANTEES, OR WARRANTIES, EXPRESS OR IMPLIED, RELATED TO THE EVALUATION BOARD INCLUDING, BUT NOT LIMITED TO, THE IMPLIED WARRANTY OF MERCHANTABILITY, TITLE, FITNESS FOR A PARTICULAR PURPOSE OR NON-INFRINGEMENT OF INTELLECTUAL PROPERTY RIGHTS. IN NO EVENT WILL ADI AND ITS LICENSORS BE LIABLE FOR ANY INCIDENTAL, SPECIAL, INDIRECT, OR CONSEQUENTIAL DAMAGES RESULTING FROM CUSTOMER'S POSSESSION OR USE OF THE EVALUATION BOARD, INCLUDING BUT NOT LIMITED TO LOST PROFITS, DELAY COSTS, LABOR COSTS OR LOSS OF GOODWILL. ADI'S TOTAL LIABILITY FROM ANY AND ALL CAUSES SHALL BE LIMITED TO THE AMOUNT OF ONE HUNDRED US DOLLARS (\$100.00). EXPORT. Customer agrees that it will not directly or indirectly export the Evaluation Board to another country, and that it will comply with all applicable United States federal laws and regulations relating to exports. GOVERNING LAW. This Agreement shall be governed by and construed in accordance with the substantive laws of the Commonwealth of Massachusetts (excluding conflict of law rules). Any legal action regarding this Agreement will be heard in the state or federal courts having jurisdiction in Suffolk County, Massachusetts, and Customer hereby submits to the personal jurisdiction and venue of such courts. The United Nations Convention on Contracts for the International Sale of Goods shall not apply to this Agreement and is expressly disclaimed.