

ASMT-UxB5-Nxxxx

Surface Mount LED Indicator



Data Sheet



Description

This family of SMT LEDs is packaged in the industry standard PLCC-2 package. These SMT LEDs have high reliability performance and are designed to work under a wide range of environmental conditions. This high reliability feature makes them ideally suited to be used under harsh interior automotive as well as interior signs application conditions.

To facilitate easy pick & place assembly, the LEDs are packed in EIA-compliant tape and reel. Every reel will be shipped in single intensity and color bin.

These LEDs are compatible with IR solder reflow process. The wide viewing angle at 120° makes these LEDs ideally suited for panel, push button, or general backlighting in automotive interior, office equipment, industrial equipment, and home appliances. The flat top emitting surface makes it easy for these LEDs to mate with light pipes. With the built-in reflector pushing up the intensity of the light output, these LEDs are also suitable to be used as LED pixels in interior electronic signs.

The super high brightness white PLCC-2 SMT LED is ideal for all kinds of backlighting applications in interior automotive, office automation, electrical appliance and industrial instrument markets to offer a clear and attractive product differentiation. The wide viewing angle at 120° also enables this white PLCC-2 SMT LED to be used in localised area ambience lighting in applications such as vanity mirror light, cabin light, and car door puddle light. The white color backlighting offered by this series of white PLCC-2 SMT LED is suitable to backlight color LCD screen in applications such as GPS (global positioning system) screens in cars.

Features

- Industry standard PLCC-2 package
- High reliability LED package
- High brightness using InGaN dice technologies
- Super wide viewing angle at 120°
- Available in 8 mm carrier tape on 7 inch reel
- Stable & Consistent performance with minimum degradation with Silicone Encapsulation
- Compatible with IR soldering process

Applications

- Interior automotive
 - Instrument panel backlighting
 - Central console backlighting
 - Cabin backlighting
- Electronic signs and signals
 - Interior full color sign
 - Variable message sign
- Office automation, home appliances, industrial equipment
 - Front panel backlighting
 - Push button backlighting
- Display backlighting

CAUTION: ASMT-UxB5-Nxxxx LEDs are Class 1C ESD sensitive. Please observe appropriate precautions during handling and processing. Refer to Avago Application Note AN-1142 for additional details.

Package Dimensions

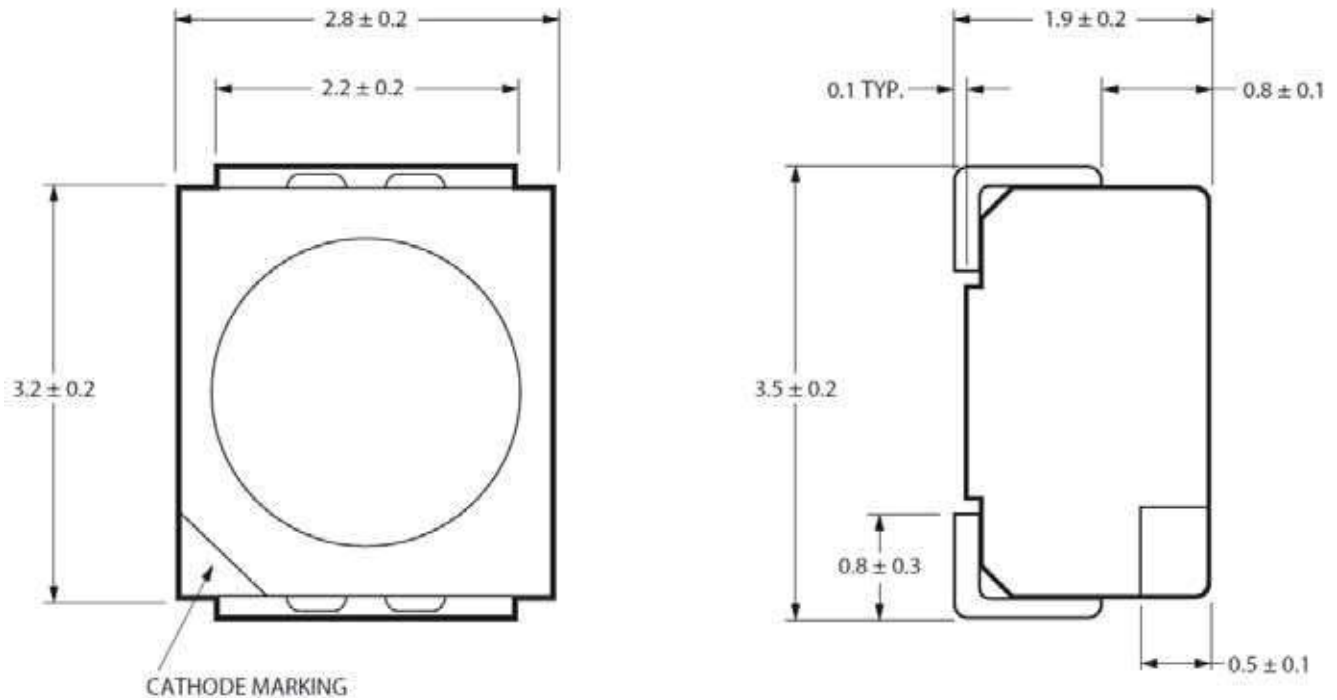

NOTE: ALL DIMENSIONS IN MILLIMETERS.

Table 1. Device Selection Guide

Color	Part Number	Min IV (mcd)	Max. IV (mcd)	Test Current (mA)	Dice Technology
Blue	ASMT-UBB5-NS8Q2	224.00	560.00	20	InGaN
Green	ASMT-UGB5-NV702	900.00	1800.00	20	InGaN

Notes:

1. The luminous intensity IV, is measured at the mechanical axis of the lamp package. The actual peak of the spatial radiation pattern may not be aligned with this axis.
2. IV Tolerance = $\pm 12\%$

Part Numbering System

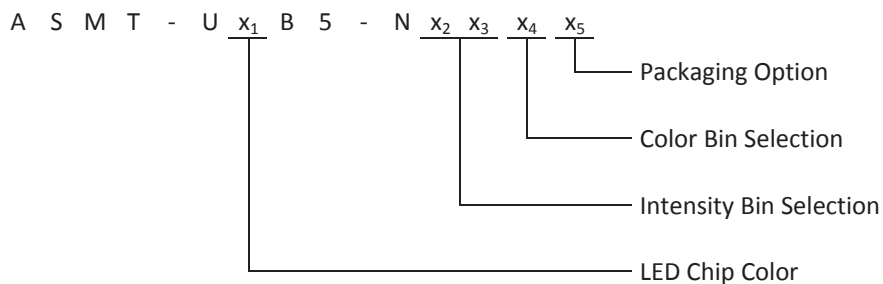

Table 2. Absolute Maximum Ratings (T_A = 25 °C)

Parameters	ASMT-UxB5
DC Forward Current ^[1]	20mA
Peak Forward Current ^[2]	100mA
Power Dissipation	114 mW
Reverse Voltage	5 V
Junction Temperature	110 °C
Operating Temperature	- 40 °C to + 100 °C
Storage Temperature	- 40 °C to + 100 °C

Notes:

1. Derate linearly as shown in Figure 4.
2. Duty Factor = 10%, Frequency = 1kHz.
3. Drive current between 10 mA and 20 mA is recommended for best long term performance.
4. Operation at current below 5 mA is not recommended.

Table 3. Optical Characteristics (T_A = 25 °C)

Color	Part Number	Dice Technology	Dominant Wavelength ^[1]	Viewing Angle 2θ _½ ^[2]
			λ _D (nm) Typ.	(Degrees) Typ.
Blue	ASMT-UBB5	InGaN	470	120
Green	ASMT-UGB5	InGaN	525	120

Notes:

1. The chromaticity coordinates are derived from the CIE 1931 Chromaticity Diagram and represent the perceived color of the device
2. θ_½ is the off-axis angle where the luminous intensity is ½ the peak intensity.

Table 4. Electrical Characteristics (T_A = 25 °C)

Part Number	Forward Voltage V _F (Volts) @ I _F = 20 mA		Reverse Voltage V _R @ 10μA	Thermal Resistance Rθ _{Jp} (°C/W)
	Typ.	Max.	Min.	
ASMT-UBB5	3.2	4.1	5	280
ASMT-UGB5	3.2	4.1	5	280

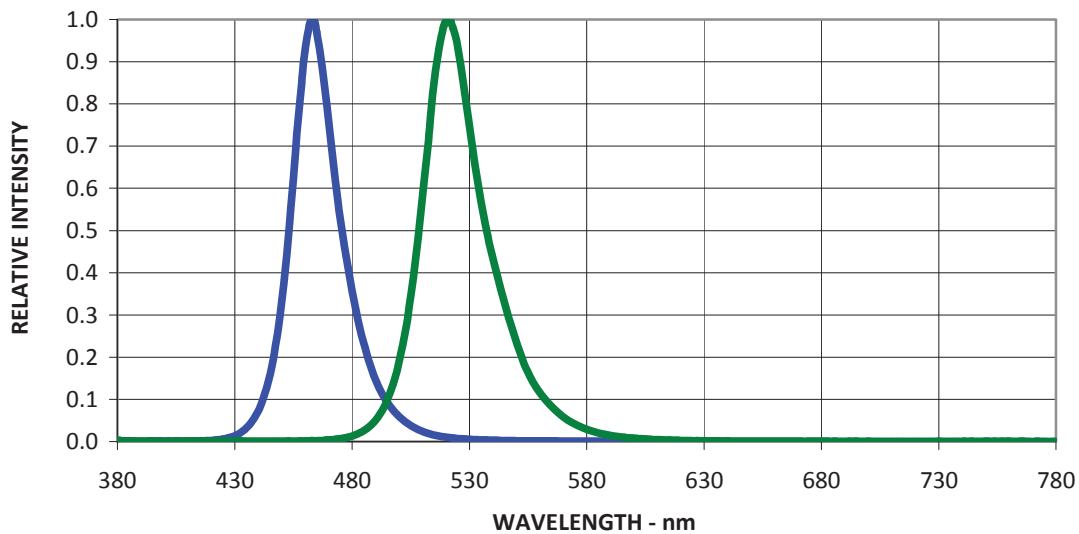

Figure 1. Relative Intensity Vs. Wavelength

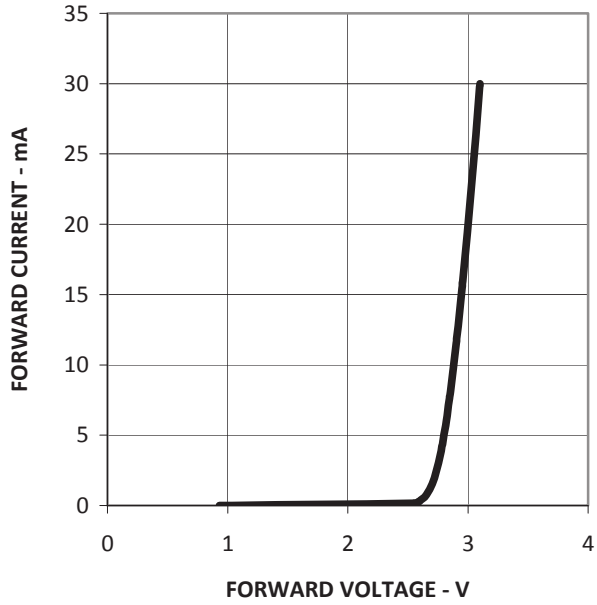

Figure 2. Forward Current Vs. Forward Voltage

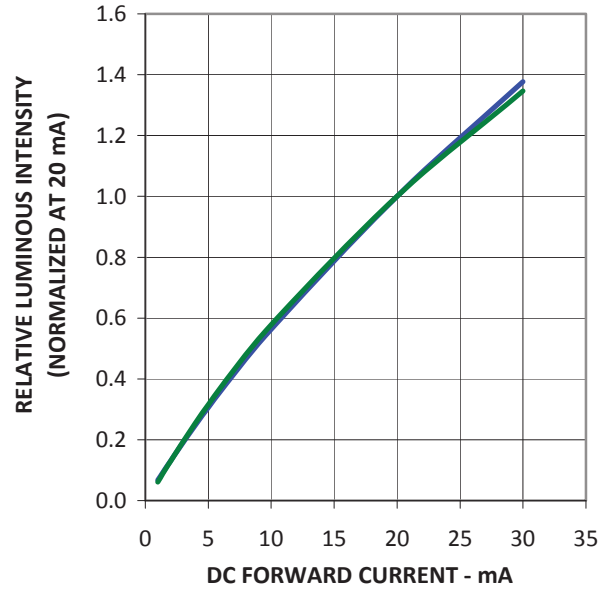

Figure 3. Relative Intensity Vs. Forward Current

Fig

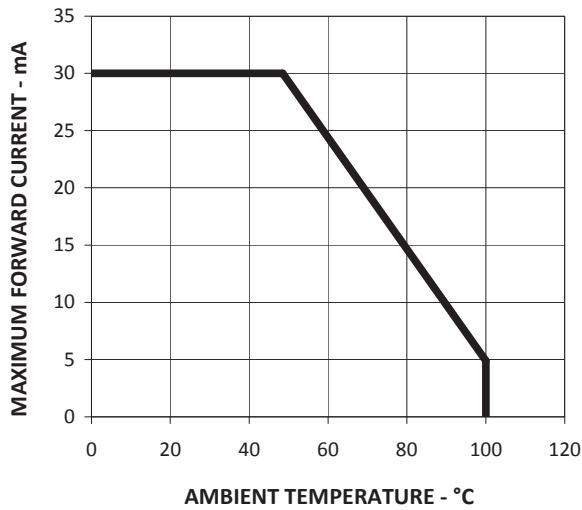

Figure 4. Maximum Forward Current Vs. Ambient Temperature. Derated Based on $T_{JMAX} = 110^{\circ}C$, $R\theta_{JA} = 500^{\circ}C/W$

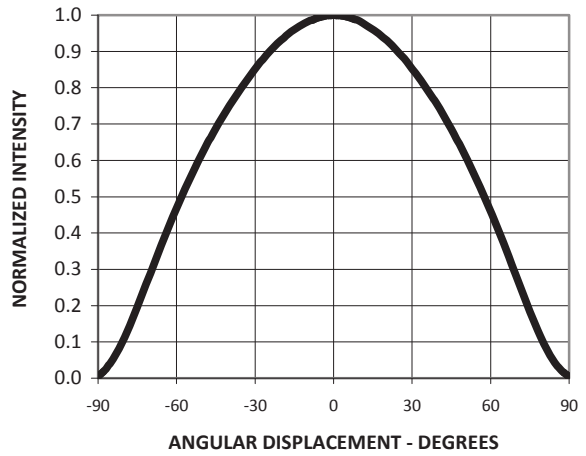
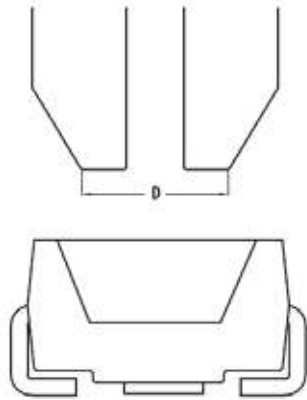
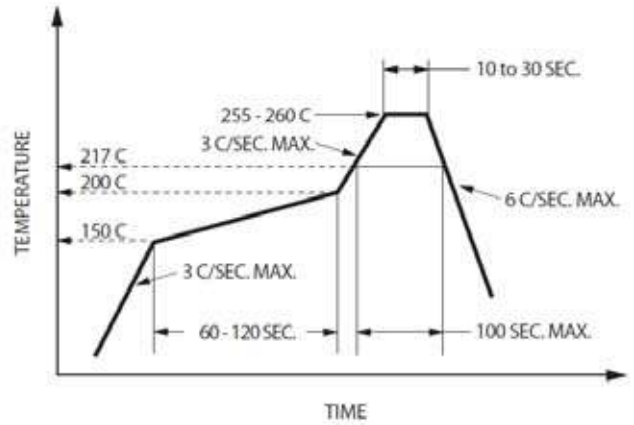

Figure 5. Radiation Pattern



Note: Diameter "D" should be smaller than 2.2mm SMT LED Indicator Components

Figure 6. Recommended Pick and Place Nozzle Size



Note: For detail information on reflow soldering of Avago surface mount LEDs, do refer to Avago Application Note AN 1060 Surface Mounting

Figure 7. Recommended Pb-free Reflow Soldering Profile

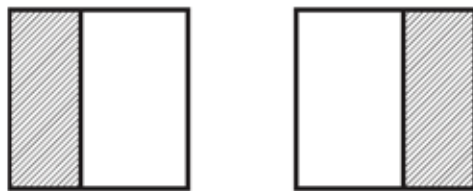
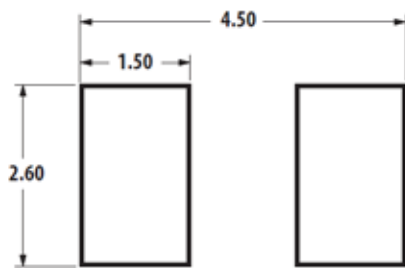

 SOLDER RESIST

Figure 8. Recommended Soldering Pad Pattern

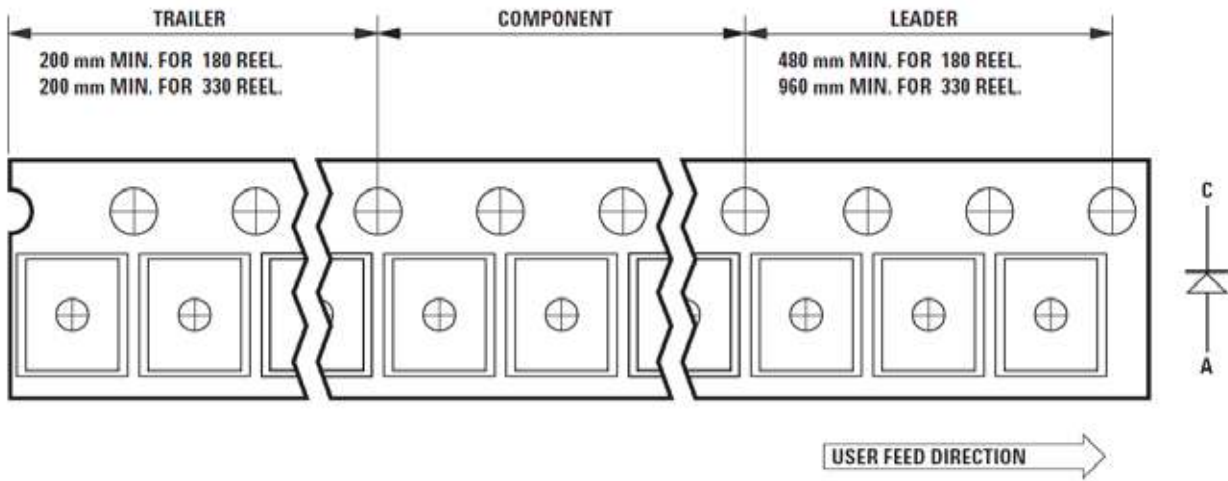

Figure 9. Tape Leader and Trailer Dimensions

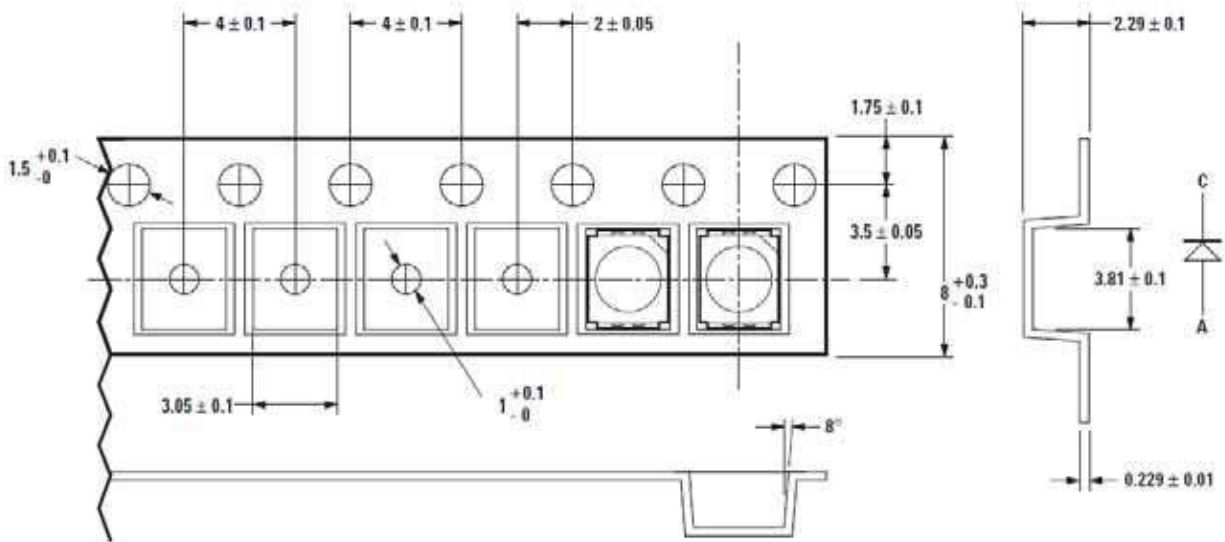

Figure 10. Tape Dimensions

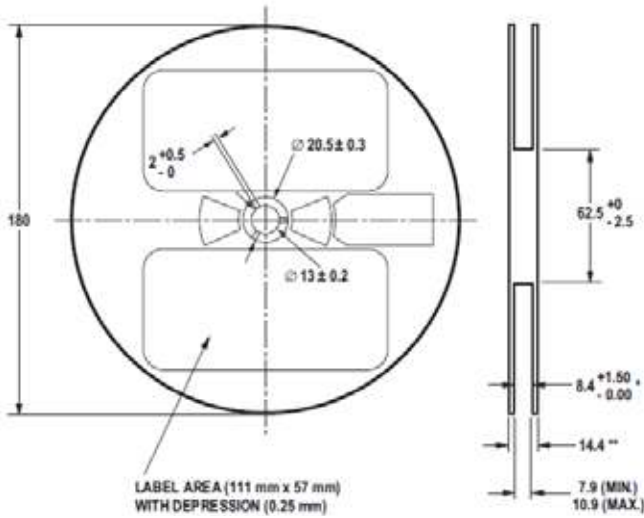

Figure 11. Reel dimensions

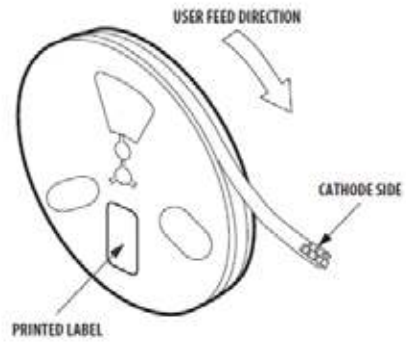

Figure 12. Reeling Orientation

Intensity Bin Select (X₂X₃)

Individual reel will contain parts from one half bin only

X ₂	Min I _v Bin
X ₃	
0	Full Distribution
A	1 half bins starting from X ₂ 1
2	2 half bins starting from X ₂ 1
3	3 half bins starting from X ₂ 1
4	4 half bins starting from X ₂ 1
5	2 half bins starting from X ₂ 1
B	1 half bins starting from X ₂ 2
6	2 half bins starting from X ₂ 2
7	3 half bins starting from X ₂ 2
8	4 half bins starting from X ₂ 2
9	2 half bins starting from X ₂ 2

Intensity Bin Limits

Bin ID	Min. (mcd)	Max. (mcd)
N1	35.50	45.00
N2	45.00	56.00
P1	45.00	56.00
P2	56.00	71.50
Q1	71.50	90.00
Q2	90.00	112.50
R1	112.50	140.00
R2	140.00	180.00
S1	180.00	224.00
S2	224.00	285.00
T1	285.00	355.00
T2	355.00	450.00
U1	450.00	560.00
U2	560.00	715.00
V1	715.00	900.00
V2	900.00	1125.00
W1	1125.00	1400.00
W2	1400.00	1800.00
X1	1800.00	2240.00
X2	2240.00	2850.00
Y1	2850.00	3550.00
Y2	3550.00	4500.00
Z1	4500.00	5600.00
Z2	5600.00	7150.00

Tolerance of each bin limit = ± 12%

Color Bin Select (X₄)

Individual reel will contain parts from one full bin only.

X ₄	
0	Full Distribution
Z	A and B only
Y	B and C only
W	C and D only
V	D and E only
U	E and F only
T	F and G only
S	G and H only
Q	A, B, and C only
P	B, C, and D only
N	C, D, and E only
M	D, E, and F only
L	E, F, and G only
K	F, G, and H only
1	A, B, C, and D only
2	E, F, G, and H only
3	B, C, D, and E only
4	C, D, E, and F only
5	A, B, C, D, and E only
6	B, C, D, E, and F only

Color Bin Limits

Blue	Min.(nm)	Max.(nm)
A	460.0	465.0
B	465.0	470.0
C	470.0	475.0
D	475.0	480.0
Green	Min.(nm)	Max.(nm)
A	515.0	520.0
B	520.0	525.0
C	525.0	530.0
D	530.0	535.0

Tolerance of each bin limit = ± 1 nm.

Packaging Option (X₅)

Option	Test Current	Package Type	Reel Size
2	20mA	Top Mount	7 inch

Handling Precaution

The encapsulation material of the product is made of silicone for better reliability of the product. As silicone is a soft material, please do not press on the silicone or poke a sharp object onto the silicone. These might damage the product and cause premature failure. During assembly or handling, the unit should be held on the body only. Please refer to Avago Application Note AN 5288 for detail information.

Moisture Sensitivity

This product is qualified as Moisture Sensitive Level 2a per Jedec J-STD-020. Precautions when handling this moisture sensitive product is important to ensure the reliability of the product. Do refer to Avago Application Note AN5305 Handling of Moisture Sensitive Surface Mount Devices for details.

A. Storage before use

- Unopen moisture barrier bag (MBB) can be stored at 40°C/90%RH for 12 months. If the actual shelf life has exceeded 12 months and the HIC indicates that baking is not required, then it is safe to reflow the LEDs per the original MSL rating.
- It is not recommended to open the MBB prior to assembly (e.g. for IQC).

B. Control after opening the MBB

- The humidity indicator card (HIC) shall be read immediately upon opening of MBB.
- The LEDs must be kept at 30°C / 60%RH at all time and all high temperature related process including soldering, curing or rework need to be completed within 672 hours.

C. Control for unfinished reel

- For any unused LEDs, they need to be stored in sealed MBB with desiccant or desiccator at 5%RH.
-

D. Control of assembled boards

- If the PCB soldered with the LEDs is to be subjected to other high temperature processes, the PCB need to be stored in sealed MBB with desiccant or desiccator at 5%RH to ensure no LEDs have exceeded their floor life of 672 hours.

E. Baking is required if:

- The HIC indicator is not GREEN at 10% and is AZURE at 5%.
- The LEDs are exposed to condition of >math>30^{\circ}\text{C}</math> / 60% RH at any time.
- The LEDs floor life exceeded 672 hours.

Recommended baking condition: $60\pm 5^{\circ}\text{C}$ for 20 hours.

For product information and a complete list of distributors, please go to our web site:

www.avagotech.com

Avago, Avago Technologies, and the A logo are trademarks of Avago Technologies, Pte. in the United States and other countries.

Data subject to change. Copyright © 2005 Avago Technologies Pte. All rights reserved.

May 13, 2011

