

THIS DRAWING IS UNPUBLISHED. RELEASED FOR PUBLICATION  
 © COPYRIGHT 2010 BY TYCO ELECTRONICS CORPORATION. ALL RIGHTS RESERVED.

LOC	DIST	REVISIONS					
DW	-	P	LTR	DESCRIPTION	DATE	DWN	APVD
		B		ECR-13-001067	18JAN13	AW	WK

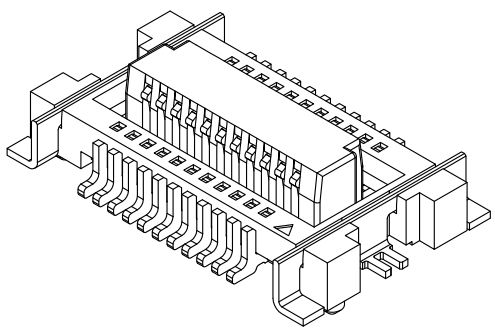
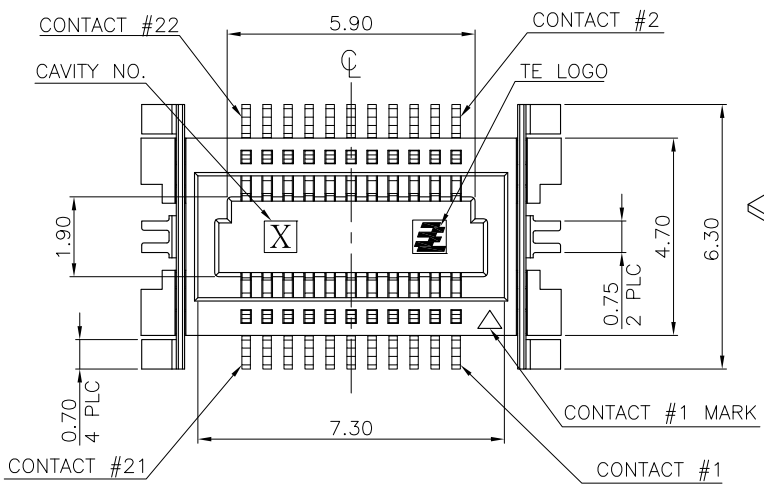

NOTES:

- MATERIAL:  
HOUSING: LCP WITH 35% GF, UL94 V-0, NATURAL COLOR.  
CONTACTS: PHOSPHOR BRONZE.  
PEGS: BRASS.
  - FINISH:  
CONTACTS: 0.0254µm [1µ"] MIN. GOLD PLATED OVER 1.27µm [50µ"] MIN. NICKEL ON ENTIRE CONTACT.  
PEGS: 3.05µm [120µ"] MIN. MATTE-TIN OVER 1.27µm [50µ"] MIN. NICKEL.
  - REFLOW SOLDER CAPABLE TO 260°C PER TEC-109-201, CONDITION B.
  - SUBSTANCE RESTRICTIONS FOR LOW HALOGEN (BY WEIGHT):  
BROMINE (Br) ≤ 900 PPM (0.09%)  
CHLORINE (Cl) ≤ 900 PPM (0.09%)  
TOTAL CONCENTRATION OF CHLORINE (Cl) + BROMINE (Br) ≤ 1500 PPM (0.15%)
- ⚠ MATING PLUG PART NUMBER: 2041301-1.

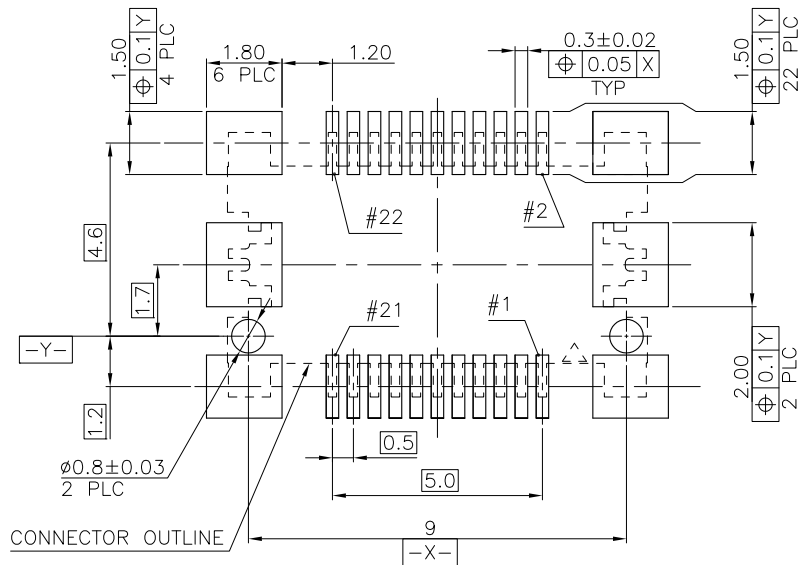
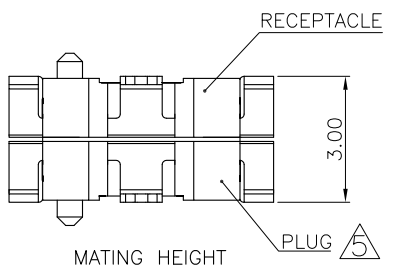
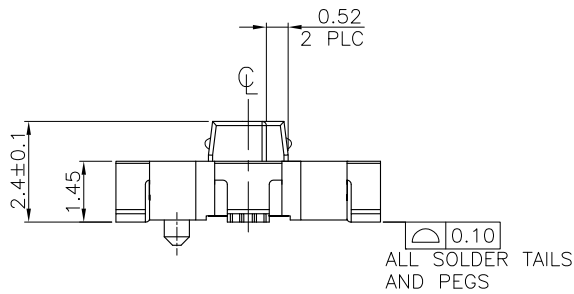
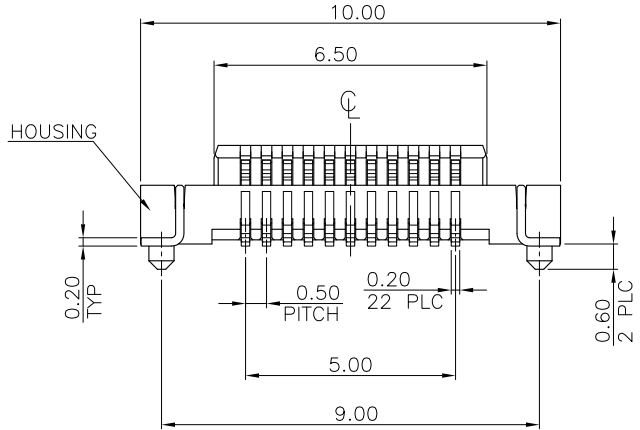

TOLERANCE: ±0.05  
 RECOMMENDED PCB LAYOUT  
 (TOP VIEW)

2041300-1  
 PART NUMBER

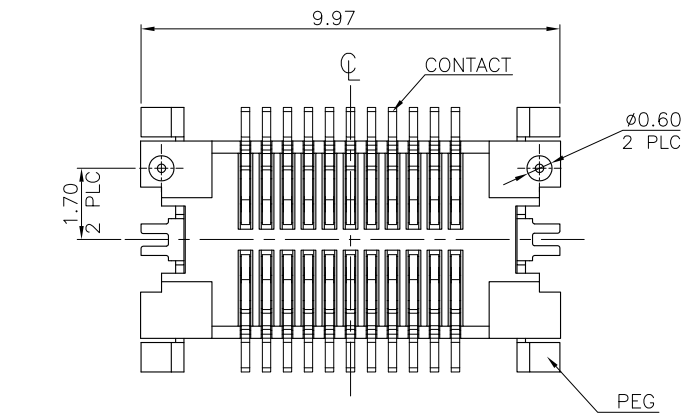

THIS DRAWING IS A CONTROLLED DOCUMENT.		DWN	A. WU	02NOV2010	TE Connectivity NAME 0.5 PITCH BOARD-TO-BOARD CONNECTOR, SMT, 22 POSITION, RECEPTACLE SIZE CAGE CODE DRAWING NO RESTRICTED TO A3 00779 C=2041300 WEIGHT 0.174 GRAMS				
DIMENSIONS: MM		CHK	S. CHIEN	02NOV2010					
TOLERANCES UNLESS OTHERWISE SPECIFIED:		APVD	W. KODAMA	02NOV2010					
0 PLC ±0.5 1 PLC ±0.3 2 PLC ±0.2 3 PLC ±0.15 4 PLC ±0.1 ANGLES ± 3°		PRODUCT SPEC	108-57849						
MATERIAL	SEE NOTE	APPLICATION SPEC	-		SCALE	SHEET	1 of 2	REV	B
CUSTOMER DRAWING		SCALE		SHEET		1 of 2		REV	

THIS DRAWING IS UNPUBLISHED. RELEASED FOR PUBLICATION  
 © COPYRIGHT 2010 BY TYCO ELECTRONICS CORPORATION. ALL RIGHTS RESERVED.

LOC	DIST	REVISIONS					
DW	-	P	LTR	DESCRIPTION	DATE	DWN	APVD
				SEE SHEET 1.			

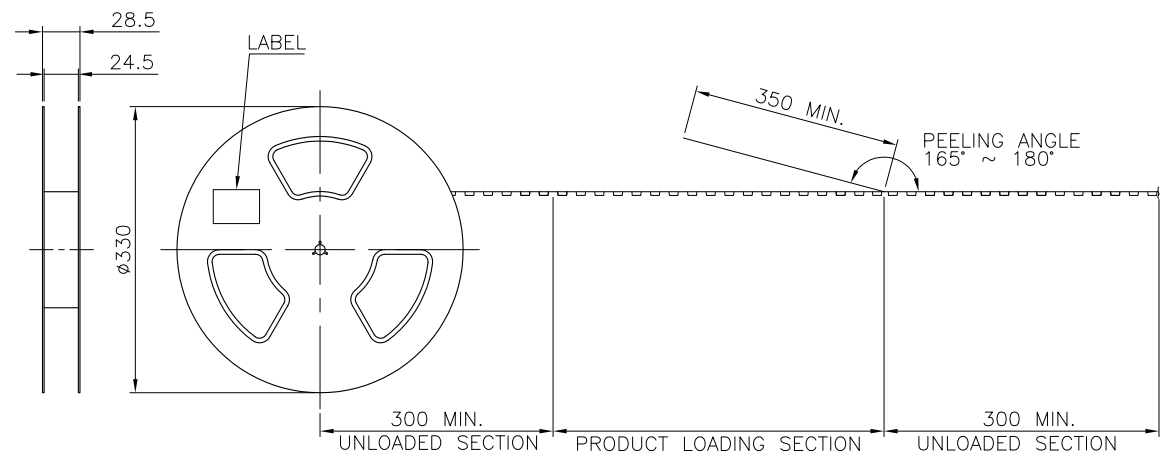

NOTES:

- MATERIAL:  
 BOX: FIBREBOARD, CORRUGATED, DOUBLE WALL.  
 COVER TAPE: PET, TRANSPARENT COLOR.  
 CARRIER TAPE: POLYSTYRENES, TRANSPARENT COLOR.  
 REEL: HIPS, BLUE COLOR.  
 BAG: POLYETHYLENES, TRANSPARENT COLOR.
- EACH BAG SHALL BE INCLUDED DESICCANT.
- PEELING STRENGTH: 0.1 ~ 1.3 N (10 ~ 130 GRAMS).
- PEELING SPEED: 300 mm/min.

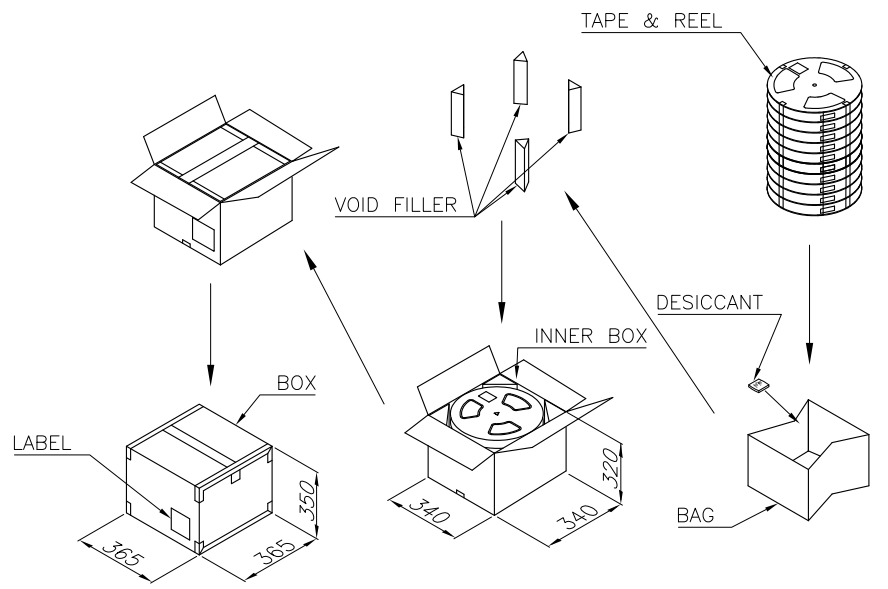
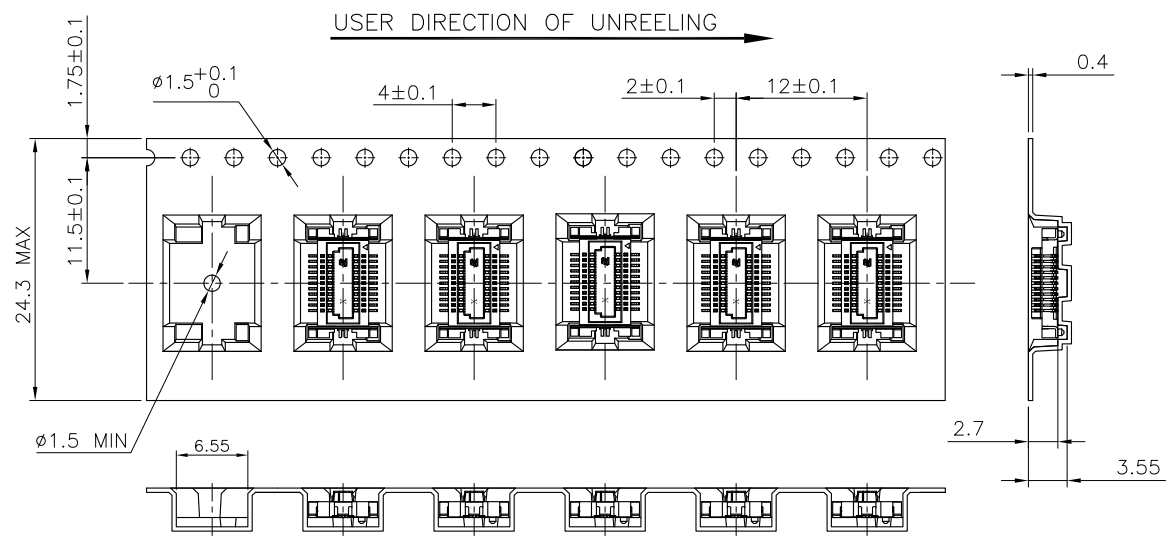

1500	10	15000 PCS	7.51 KG	2.61 KG
PCS/TAPE	REELS/BOX	QUANTITY	GROSS WEIGHT	NET WEIGHT

THIS DRAWING IS A CONTROLLED DOCUMENT.		DWN	A. WU	02NOV2010	 <b>STE</b> TE Connectivity								
DIMENSIONS: MM		CHK	S. CHIEN	02NOV2010									
TOLERANCES UNLESS OTHERWISE SPECIFIED:		APVD	W. KODAMA	02NOV2010									
0 PLC ± - 1 PLC ± - 2 PLC ± - 3 PLC ± - 4 PLC ± - ANGLES ± -		NAME	0.5 PITCH BOARD-TO-BOARD CONNECTOR, SMT, 22 POSITION, RECEPTACLE										
MATERIAL	FINISH	APPLICATION SPEC	-		SIZE	A3	CAGE CODE	00779	DRAWING NO	C=2041300	RESTRICTED TO	-	
		WEIGHT	-		CUSTOMER DRAWING			SCALE	-	SHEET	2 of 2	REV	B