



The Future of Analog IC Technology®

EV8904DD-00A

500mA Low-Current LDO Linear Regulator EV Board

DESCRIPTION

The EV8904DD-00A evaluation board demonstrates the performance of MP8904, a monolithic low-current, low-dropout LDO linear regulator. It operates from a 2.5V to 6.5V input bias voltage and regulates the output voltage from as low as 0.5V.

It requires a bias supply (2.5V to 6.5V) separate from V_{IN} to run the internal reference and LDO drive circuitry. The output current comes directly from the input voltage supply for high efficiency regulation. The 0.5V internal reference voltage allows the output to be programmed to a range of 0.5V to 5V.

The EV8904DD-00A provides thermal overload and current limit protection. The MP8904 is available in an 8-pin QFN (2mm x 3mm) package.

ELECTRICAL SPECIFICATIONS

Parameter	Symbol	Value	Units
Input Voltage	V_{IN}	2.5 – 6.5	V
Dropout Voltage	$V_{DROPOUT}$	300	mV
Output Current	I_{OUT}	0.5	A

FEATURES

- Wide 2.5V to 6.5V Input Voltage Range
- Stable with Very Small Ceramic Capacitors
- 300mV Dropout at 500mA Output
- 2% Feedback Accuracy
- Adjustable Output Range from 0.5V to 5V
- Stable With Low-ESR Output Capacitors
- Low 100µA Ground Current
- Internal Thermal Protection
- Current Limit Protection
- Fully Assembled and Tested

APPLICATIONS

- Low Current Regulators
- Battery-Powered Systems
- Mobile Devices, such as Cell Phones and GPS Navigators

All MPS parts are lead-free, halogen free, and adhere to the RoHS directive. For MPS green status, please visit MPS website under Quality Assurance. "MPS" and "The Future of Analog IC Technology" are Registered Trademarks of Monolithic Power Systems, Inc.

EV8904DD-00A EVALUATION BOARD



Board Number	MPS IC Number
EV8904DD-00A	MP8904

Voltage Dropout vs Current

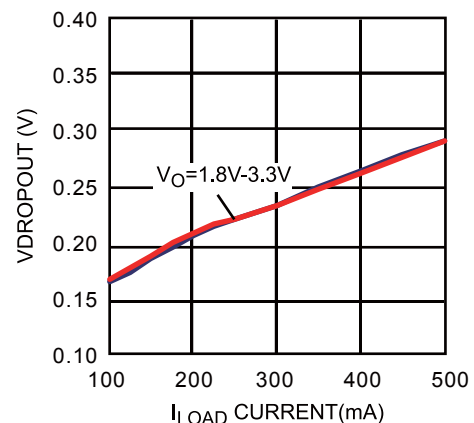

EVALUATION BOARD SCHEMATIC

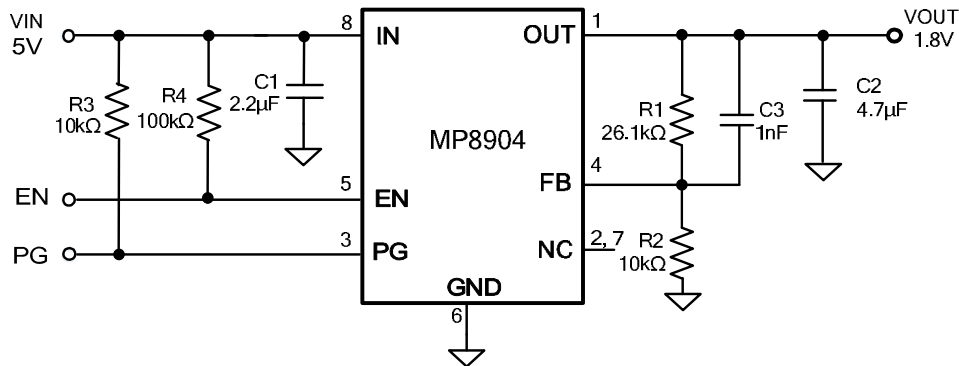

EV8904DD-00A BILL OF MATERIALS

Qty	Ref	Value	Description	Package	Manufacturer	Manufacturer P/N
1	C1	2.2μF	Ceramic Cap., X7R, 16V	1206	TDK	C3216X7R1C225K
1	C2	4.7μF	Ceramic Cap., X7R, 16V	1206	TDK	C3216X7R1C475K
1	C3	1nF	Ceramic Cap. 25V X7R	0603	muRata	GRM188R71E102KA01D
1	R1	26.1kΩ	Film Res., 1%	0603	Panasonic	ERJ-3EKF2612V
2	R2, R3	10kΩ	Film Res., 1%	0603	Panasonic	ERJ-3EKF1002V
1	R4	100kΩ	Film Res., 1%	0603	ROYAL	RL0603FR-07100KL
1	U1	MP8904	Linear Regulator	QFN-8	MPS	MP8904DD

PRINTED CIRCUIT BOARD LAYOUT

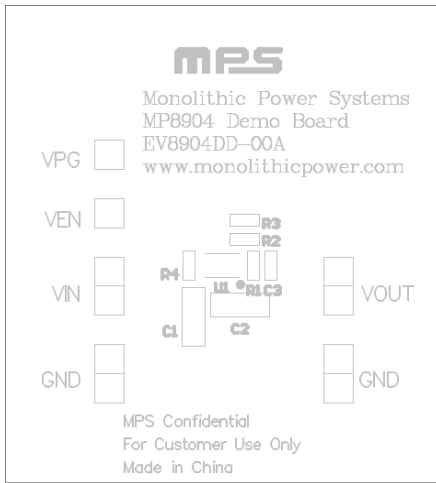

Figure 1—Top Silk Layer

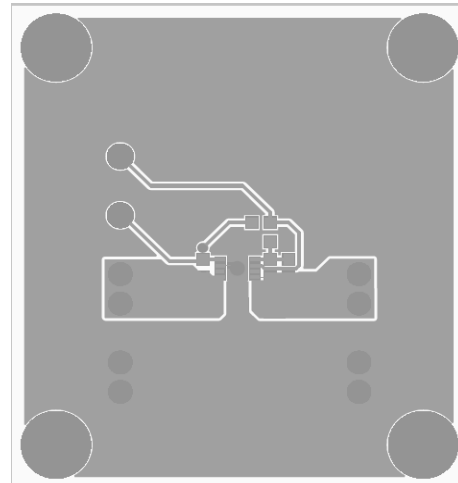

Figure 2—Top Layer

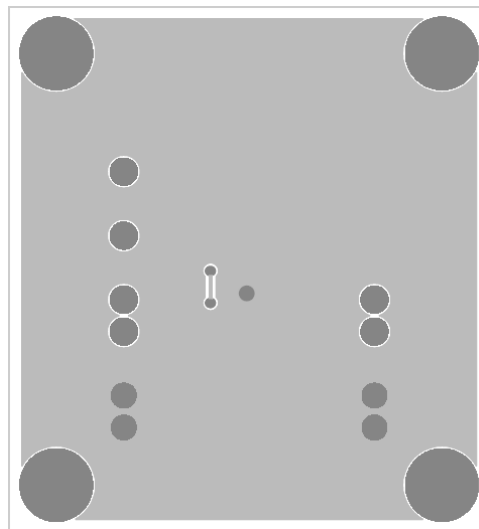

Figure 3—Bottom Layer

QUICK START GUIDE

The output voltage of this board is set to 1.8V.

1. Connect the positive and negative terminals of the load to the VOUT and GND pins respectively.
2. Preset the power supply output between 2.5V and 6.5V, and then turn off the power supply.
3. Connect the positive and negative terminals of the power supply output to the VIN and GND pins, respectively.
4. Turn the power supply on. The board will automatically start up.
5. To use the Enable function, apply a digital input to the EN pin. Drive EN higher than 1.2V to turn on the regulator or less than 0.4V to turn it off.
6. The default resistor values on the board are R1=26.1kΩ and R2=10kΩ. Changing these resistor values will change the output voltage. Use the following equation to determine resistor values for different output voltages:

$$V_{OUT} = 0.5V \times \left(1 + \frac{R1}{R2}\right)$$

NOTICE: The information in this document is subject to change without notice. Users should warrant and guarantee that third party Intellectual Property rights are not infringed upon when integrating MPS products into any application. MPS will not assume any legal responsibility for any said applications.