

2N6473 2N6474 NPN
2N6475 2N6476 PNP

**COMPLEMENTARY
SILICON SWITCHING TRANSISTORS**

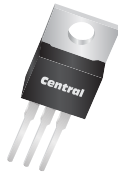

TO-220 CASE



www.centrasemi.com

DESCRIPTION:

The CENTRAL SEMICONDUCTOR 2N6473, 2N6475 series types are complementary silicon power transistors, manufactured by the epitaxial base process, designed for general purpose amplifier and switching applications.

MARKING: FULL PART NUMBER

MAXIMUM RATINGS: ($T_C=25^\circ\text{C}$)

Collector-Base Voltage
Collector-Emitter Voltage ($R_{BE}=100\Omega$)
Collector-Emitter Voltage
Emitter-Base Voltage
Continuous Collector Current
Continuous Base Current
Power Dissipation
Operating and Storage Junction Temperature
Thermal Resistance

SYMBOL	2N6473	2N6474	UNITS
	2N6475	2N6476	
V_{CBO}	110	130	V
V_{CER}	110	130	V
V_{CEO}	100	120	V
V_{EBO}		5.0	V
I_C		4.0	A
I_B		2.0	A
P_D		40	W
T_J, T_{stg}		-65 to +150	$^\circ\text{C}$
θ_{JC}		3.125	$^\circ\text{C/W}$

ELECTRICAL CHARACTERISTICS: ($T_C=25^\circ\text{C}$ unless otherwise noted)

SYMBOL	TEST CONDITIONS	2N6473		2N6474		UNITS
		2N6475	MIN	MAX	MIN	
I_{CEV}	$V_{CE}=\text{Rated } V_{CEO}, V_{BE}=1.5\text{V}$	-	100	-	100	μA
I_{CEV}	$V_{CE}=\text{Rated } V_{CEO}, V_{BE}=1.5\text{V}, T_C=100^\circ\text{C}$	-	2.0	-	2.0	mA
I_{CER}	$V_{CE}=\text{Rated } V_{CER}, R_{BE}=100\Omega$	-	100	-	100	μA
I_{CER}	$V_{CE}=\text{Rated } V_{CER}, R_{BE}=100\Omega, T_C=100^\circ\text{C}$	-	2.0	-	2.0	mA
I_{CEO}	$V_{CE}=1/2 \text{ Rated } V_{CEO}$	-	1.0	-	1.0	mA
I_{EBO}	$V_{EB}=5.0\text{V}$	-	1.0	-	1.0	mA
BV_{CEO}	$I_C=100\text{mA}$	100	-	120	-	V
BV_{CER}	$I_C=100\text{mA}, R_{BE}=100\Omega$	110	-	130	-	V
$V_{CE(SAT)}$	$I_C=1.5\text{A}, I_B=0.15\text{A}$	-	1.2	-	1.2	V
$V_{CE(SAT)}$	$I_C=4.0\text{A}, I_B=2.0\text{A}$	-	2.5	-	2.5	V
$V_{BE(ON)}$	$V_{CE}=4.0\text{V}, I_C=1.5\text{A}$	-	2.0	-	2.0	V
$V_{BE(ON)}$	$V_{CE}=2.5\text{V}, I_C=4.0\text{A}$	-	3.5	-	3.5	V
h_{FE}	$V_{CE}=4.0\text{V}, I_C=1.5\text{A}$	15	150	15	150	
h_{FE}	$V_{CE}=2.5\text{V}, I_C=4.0\text{A}$	2.0	-	2.0	-	
h_{fe}	$V_{CE}=4.0\text{V}, I_C=0.5\text{A}, f=50\text{kHz}$	20	-	20	-	
f_T	$V_{CE}=4.0\text{V}, I_C=0.5\text{A}$ (2N6473, 2N6474)	4.0	-	4.0	-	MHz
f_T	$V_{CE}=4.0\text{V}, I_C=0.5\text{A}$ (2N6475, 2N6476)	5.0	-	5.0	-	MHz
C_{ob}	$V_{CB}=10\text{V}, f=1.0\text{MHz}$	-	250	-	250	pF

R1 (1-May 2013)

2N6473 2N6474 NPN
 2N6475 2N6476 PNP



COMPLEMENTARY
 SILICON SWITCHING TRANSISTORS

TO-220 CASE - MECHANICAL OUTLINE

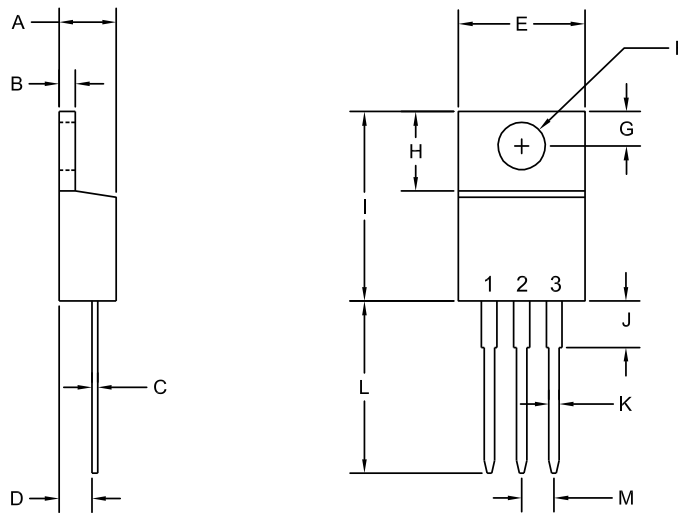

R2

LEAD CODE:

- 1) Base
- 2) Collector
- 3) Emitter
- Tab) Collector

MARKING:
 FULL PART NUMBER

SYMBOL	DIMENSIONS			
	INCHES		MILLIMETERS	
	MIN	MAX	MIN	MAX
A	0.170	0.190	4.31	4.82
B	0.045	0.055	1.15	1.39
C	0.013	0.026	0.33	0.65
D	0.083	0.107	2.10	2.72
E	0.394	0.417	10.01	10.60
F (DIA)	0.140	0.157	3.55	4.00
G	0.100	0.118	2.54	3.00
H	0.230	0.270	5.85	6.85
I	0.560	0.625	14.23	15.87
J	-	0.250	-	6.35
K	0.025	0.038	0.64	0.96
L	0.500	0.579	12.70	14.70
M	0.090	0.110	2.29	2.79

TO-220 (REV: R2)

R1 (1-May 2013)

OUTSTANDING SUPPORT AND SUPERIOR SERVICES



PRODUCT SUPPORT

Central's operations team provides the highest level of support to insure product is delivered on-time.

- Supply management (Customer portals)
- Inventory bonding
- Consolidated shipping options
- Custom bar coding for shipments
- Custom product packing

DESIGNER SUPPORT/SERVICES

Central's applications engineering team is ready to discuss your design challenges. Just ask.

- Free quick ship samples (2nd day air)
- Online technical data and parametric search
- SPICE models
- Custom electrical curves
- Environmental regulation compliance
- Customer specific screening
- Up-screening capabilities
- Special wafer diffusions
- PbSn plating options
- Package details
- Application notes
- Application and design sample kits
- Custom product and package development

REQUESTING PRODUCT PLATING

1. If requesting Tin/Lead plated devices, add the suffix "TIN/LEAD" to the part number when ordering (example: 2N2222A TIN/LEAD).
2. If requesting Lead (Pb) Free plated devices, add the suffix "PBFREE" to the part number when ordering (example: 2N2222A PBFREE).

CONTACT US

Corporate Headquarters & Customer Support Team

Central Semiconductor Corp.
145 Adams Avenue
Hauppauge, NY 11788 USA
Main Tel: (631) 435-1110
Main Fax: (631) 435-1824
Support Team Fax: (631) 435-3388
www.centrasemi.com

Worldwide Field Representatives:
www.centrasemi.com/wwreps

Worldwide Distributors:
www.centrasemi.com/wwdistributors

For the latest version of Central Semiconductor's **LIMITATIONS AND DAMAGES DISCLAIMER**, which is part of Central's Standard Terms and Conditions of sale, visit: www.centrasemi.com/terms