

Description

The AP2337 is single channel current-limited integrated high-side power switches optimized for hot-swap applications. The devices have fast short-circuit response time for improved overall system robustness and provide a complete protection solution for application subject to heavy capacitive loads and the prospect of short circuit. It offers reverse current blocking, over-current, over-temperature and short-circuit protection, as well as controlled rise time and under-voltage lockout functionality.

The device is available in SOT23 package.

Pin Assignments

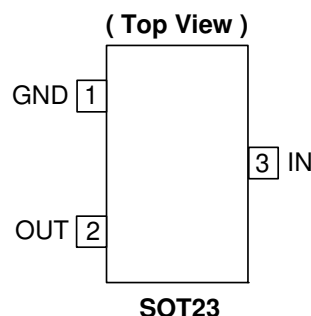

Features

- Input voltage range: 2.7V – 5.5V
- Fast short-circuit response time
- 1.5A accurate current limiting
- 110mΩ on-resistance
- Reverse Current Blocking
- Built-in soft-start with 2.5ms typical turn-on time
- Over Current Protection
- Over Voltage Protection
- Short circuit and thermal protection
- ESD protection: 3KV HBM, 300V MM
- Ambient temperature range: -40°C to 85°C
- Available in “Green” Molding Compound (No Br, Sb)
- Lead Free Finish/ RoHS Compliant (Note 1)
- UL Recognized, File Number E322375 (to be completed)
- IEC60950-1 CB Scheme Certified (to be completed)

Applications

- LCD TVs & Monitors
- Set-Top-Boxes, Residential Gateways
- Laptops, Desktops, Servers
- Printers, Docking Stations, HUBs
- Smart phones, e-Readers

Notes: 1. EU Directive 2002/95/EC (RoHS). All applicable RoHS exemptions applied. Please visit our website at http://www.diodes.com/products/lead_free.html.

Typical Application Circuit

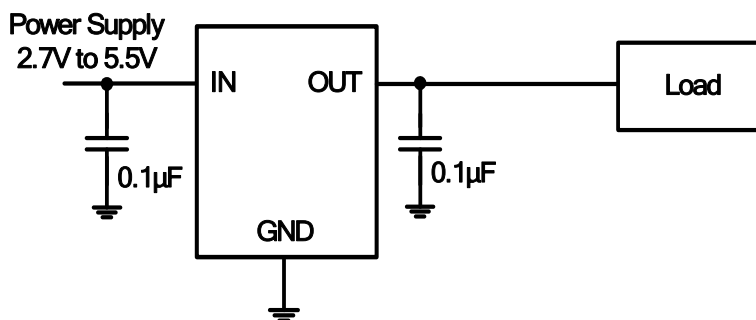

Pin Descriptions

Pin Name	Pin Number	Descriptions
GND	1	Ground
OUT	2	Switch output pin
IN	3	Voltage input pin

Function Block Diagram

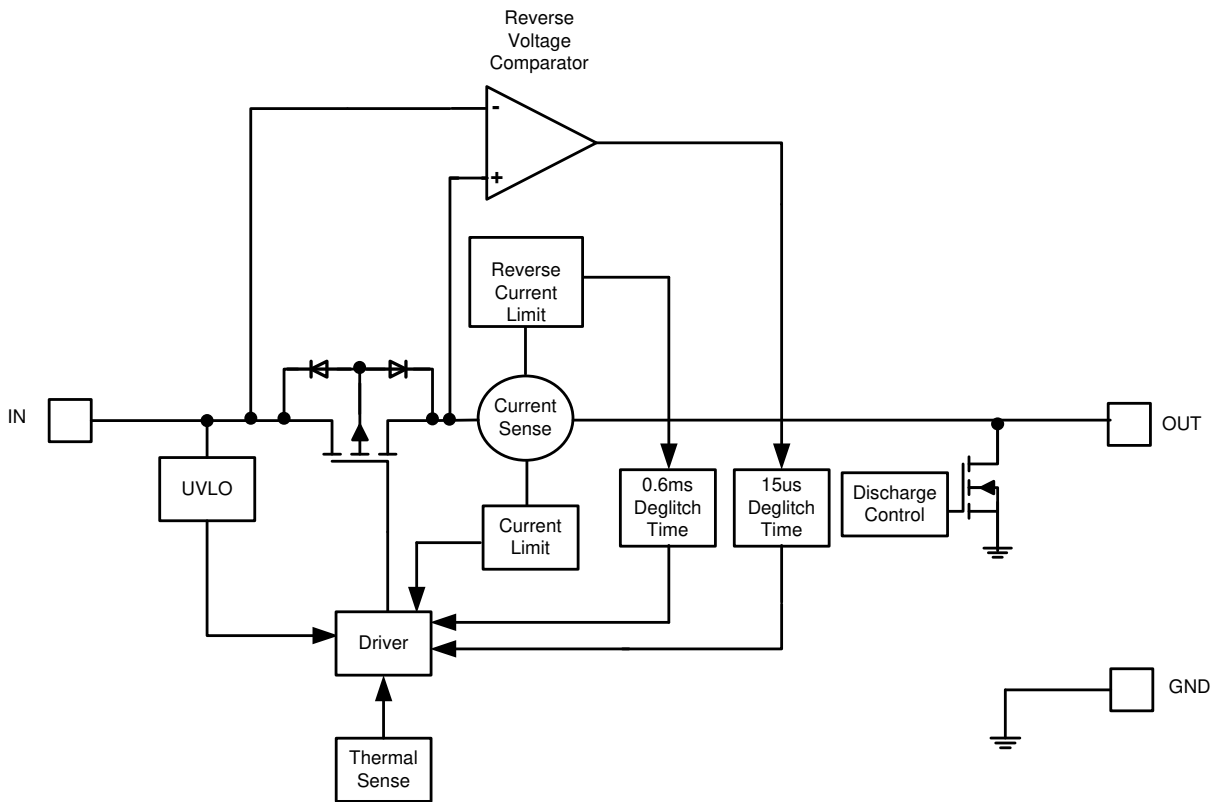

Absolute Maximum Ratings

Symbol	Parameter	Ratings	Units
ESD HBM	Human Body Model ESD Protection	3	KV
ESD MM	Machine Model ESD Protection	300	V
V_{IN}	Input Voltage	6.5	V
V_{OUT}	Output Voltage	$V_{IN} + 0.3$	V
I_{load}	Maximum Continuous Load Current	Internal Limited	A
T_{Jmax}	Maximum Junction Temperature	150	°C
T_{ST}	Storage Temperature Range (Note 2)	-65 to 150	°C

Notes: 2. UL Recognized Rating from -30°C to 70°C (Diodes qualified T_{ST} from -65°C to 150°C)

Recommended Operating Conditions

Symbol	Parameter	Min	Max	Units
V_{IN}	Input voltage	2.7	5.5	V
I_{OUT}	Output Current	0	1.0	A
T_A	Operating Ambient Temperature	-40	85	°C

Electrical Characteristics ($T_A = 25^\circ\text{C}$, $V_{IN} = +5.0\text{V}$, unless otherwise stated)

Symbol	Parameter	Test Conditions (Note 3)	Min	Typ.	Max	Unit
V_{UVLO}	Input UVLO	V_{IN} rising	2.00		2.65	V
I_Q	Input quiescent current	Above UVLO, $I_{OUT} = 0$		65	110	μA
I_{REV}	Reverse leakage current	$V_{IN} = 0\text{V}$, $V_{OUT} = 5\text{V}$, I_{REV} at V_{IN}		0.01	0.1	μA
$R_{DS(ON)}$	Switch on-resistance	$V_{IN} = 5\text{V}$, $I_{OUT} = 1\text{A}$ $V_{IN} = 3.3\text{V}$, $I_{OUT} = 1\text{A}$		110 140	140 170	$\text{m}\Omega$
I_{LIMIT}	Over-load current limit	$V_{IN} = 5\text{V}$, $V_{OUT} = 4\text{V}$, $C_L = 10\mu\text{F}$	1.1	1.5	1.9	A
I_{OS}	Short-circuit current	OUT connected to ground, $C_L = 10\mu\text{F}$	0.2	0.6	1.0	A
T_{SHORT}	Short-circuit response time	From $V_{OUT} < 0.6\text{V}$ to $I_{OUT} = 0\text{A}$ (OUT shorted to GND) (See Figure. 1)(Note 7)		5		μs
I_{ROCP}	Reverse current limit	Above UVLO	0.3	0.5	0.7	A
T_{Trig}	Deglintch time from reverse current trigger to MOSFET turn off			0.6		ms
V_{OVP}	Output over-voltage trip point	Above UVLO (Note 4)	110%		120%	V_{IN}
T_{OVP}	Debounce time from output over-voltage to MOSFET turn off			15		μs
T_{ON}	Output turn-on time (Note 5)	$C_L = 1\mu\text{F}$, $R_{load} = 5\Omega$ (UVLO to 90% $V_{OUT-NOM}$)	1		4	ms
T_{DIS}	Discharge time	$C_L = 1\mu\text{F}$, from UVLO to $V_{OUT} < 0.3\text{V}$		500		μs
T_{SHDN}	Thermal shutdown threshold			150		°C
T_{HYS}	Thermal shutdown hysteresis			20		°C
θ_{JA}	Thermal Resistance Junction-to-Ambient	(Note 6)		180		°C/W

- Notes:
3. Pulse-testing techniques maintain junction temperature close to ambient temperature; thermal effects must be taken into account separately.
 4. During output over-voltage protection, the output draws approximately 60 μA current.
 5. Since the output turn-on slew rate is dependent on input supply slew rate, this limit is only applicable for input supply slew rate between 5V/0.2ms to 5V/1ms.
 6. Device mounted on FR-4 substrate PCB, 2oz copper, with minimum recommended pad layout.
 7. Applicable for output voltage slew rate $\leq 5\text{V}/30\mu\text{s}$.

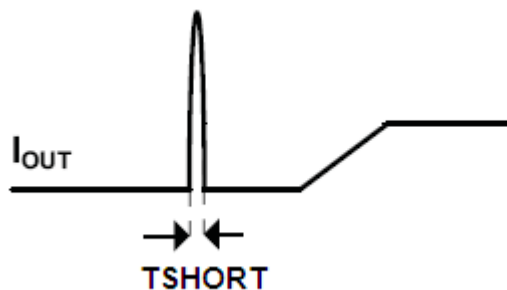

Figure 1. Short Circuit Response Time

Typical Performance Characteristics

UVLO Increasing



1ms/div

UVLO Decreasing



5ms/div

Over-Load Current Limit



50ms/div

Short Circuit Current Limit

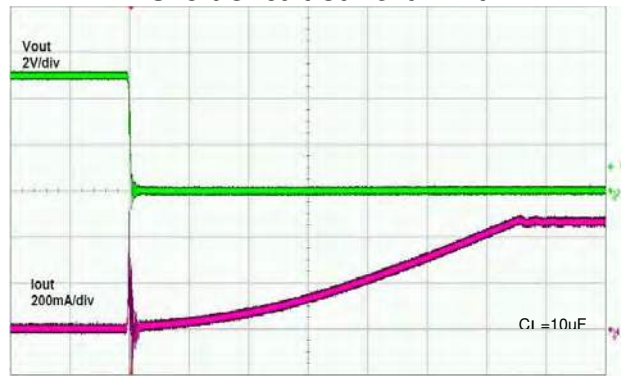

100us/div

Output Over Voltage Trip Point

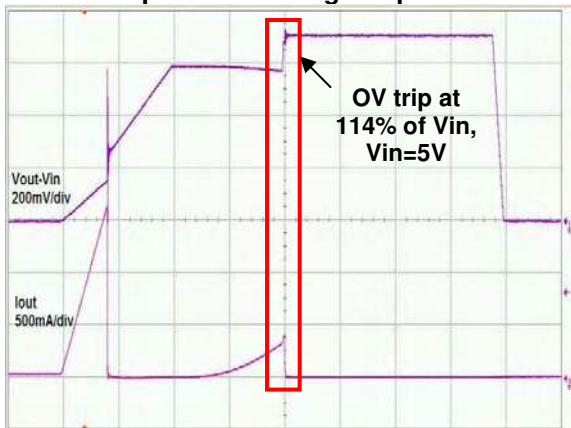

500us/div

Debounce time from output over-voltage to MOSFET turn off

(Zoom in at red portion of previous waveform)

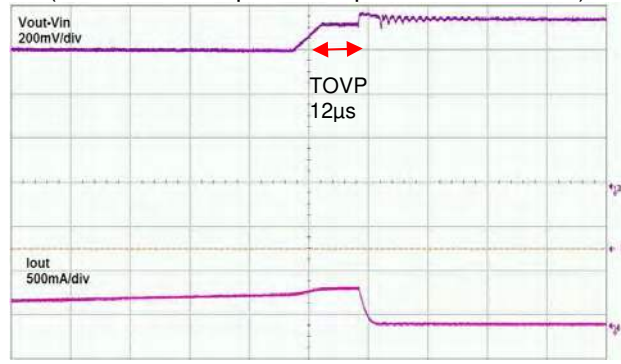

20us/div

NEW PRODUCT

Typical Performance Characteristics (cont.)

Deglitch time from reverse current trigger to MOSFET turn off

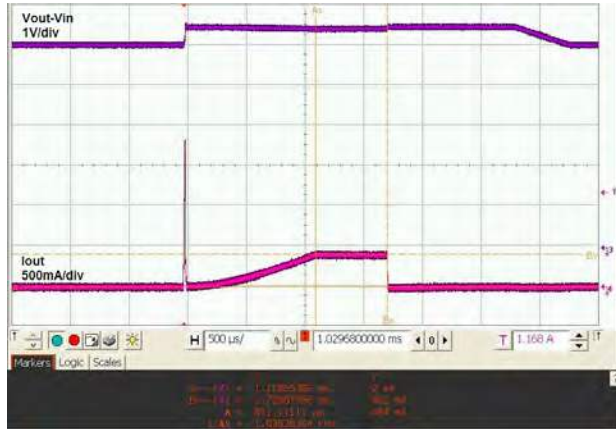

500µs/div

Reverse Current Limit

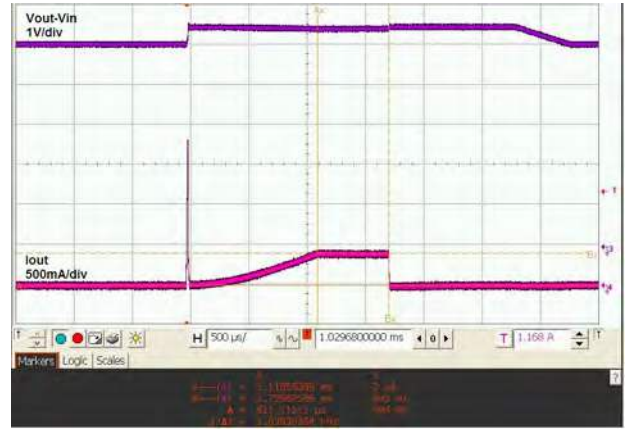

500µs/div

Output Turn-on Time

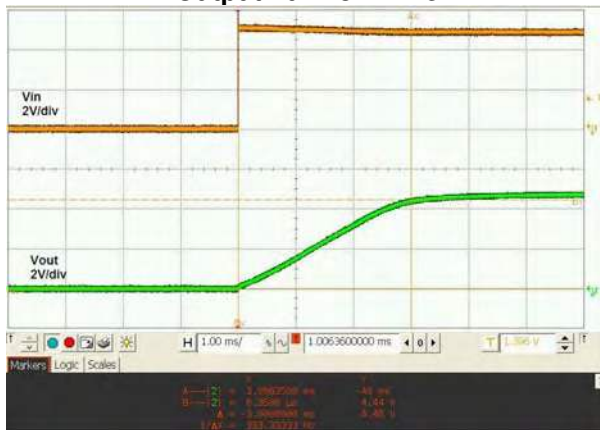

1ms/div

Discharge Time



5ms/div

NEW PRODUCT

Typical Performance Characteristics (cont.)

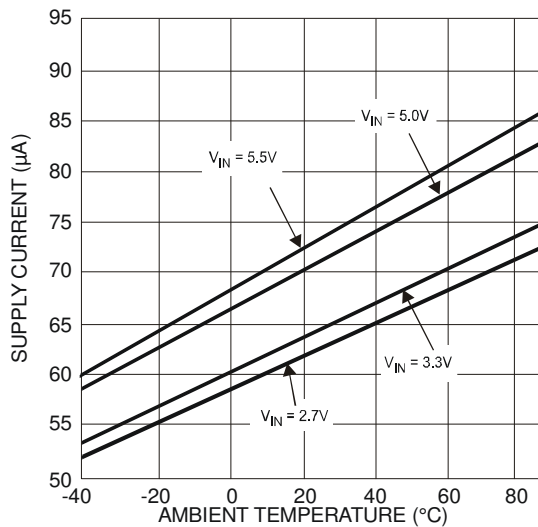

Fig. 1 Quiescent Supply Current vs. Ambient Temperature

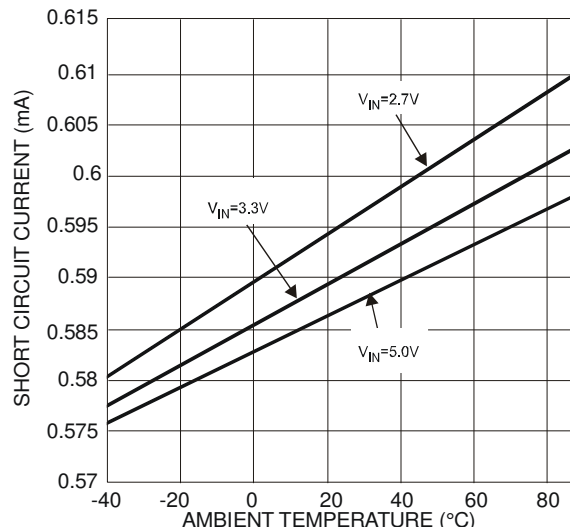

Fig. 2 Short Circuit Output Current vs. Ambient Temperature

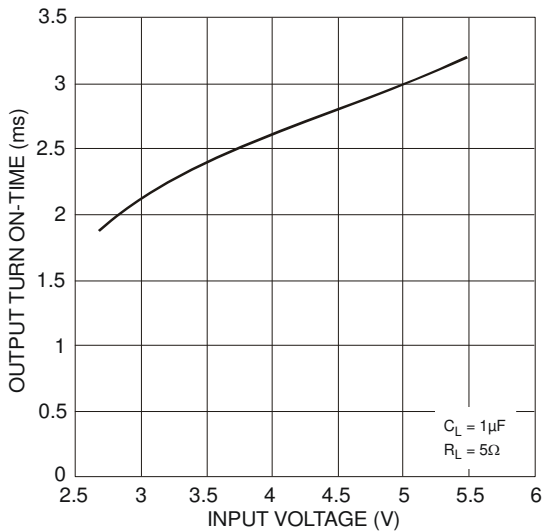

Fig. 3 Output Turn On-Time vs. Input Voltage

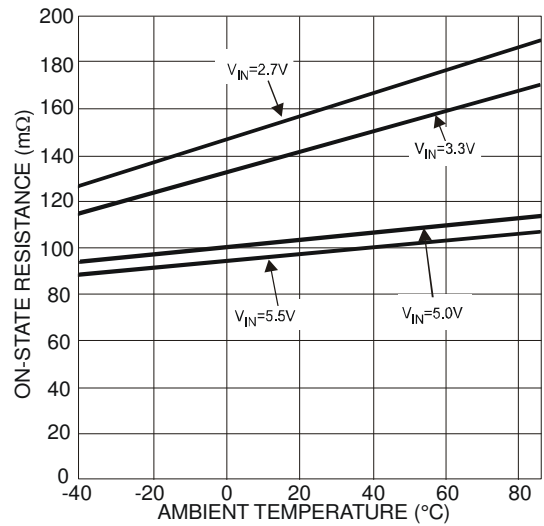

Fig. 4 Switch On-Resistance vs. Ambient Temperature

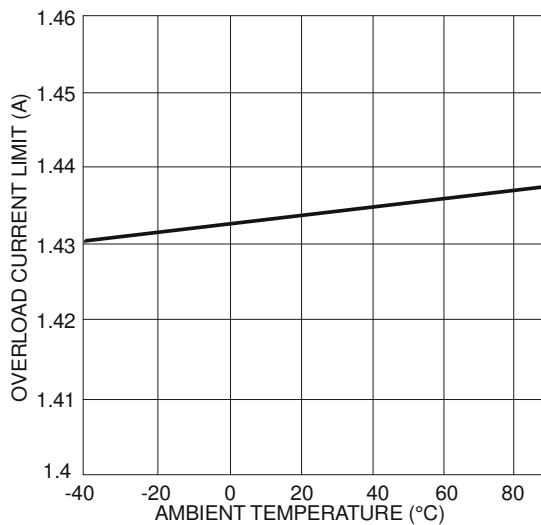

Fig. 5 Current Limit Trip Threshold vs. Ambient Temperature

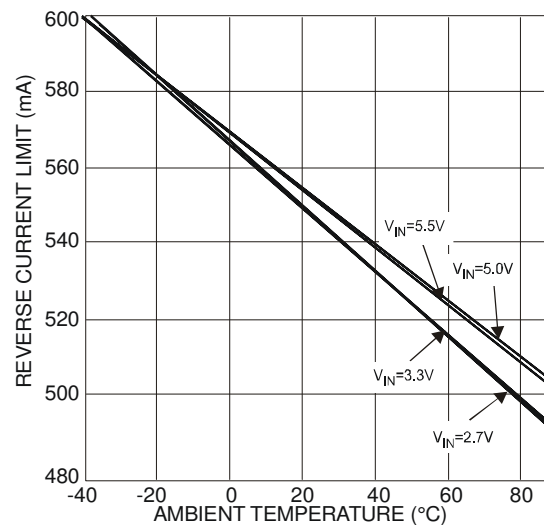

Fig. 6 Reverse Current Limit vs. Ambient Temperature

Application Note

Protection Features:

Under-voltage Lockout (UVLO)

Whenever the input voltage falls below UVLO threshold (~2.5V), the power switch is turned off. This facilitates the design of hot-insertion systems where it is not possible to turn off the power switch before input power is removed.

Over-current and Short Circuit Protection

An internal sensing FET is employed to check for over-current conditions. Unlike current-sense resistors, sense FETs do not increase the series resistance of the current path. When an overcurrent condition is detected, the device maintains a constant output current and reduces the output voltage accordingly. Complete shutdown occurs only if the fault stays long enough to activate thermal limiting.

The different overload conditions and the corresponding response of the AP2337 are outlined below:

NO	Conditions	Explanation	Behavior of the AP2337
1	Short circuit condition at start-up	Output is shorted before input voltage is applied or before the part is powered up.	The IC senses the short circuit and immediately clamps output current to a certain safe level namely I_{short}
2	Short-circuit or Overcurrent condition	Short-Circuit or Overload condition that occurs when the part is powered up and above UVLO.	<ul style="list-style-type: none"> At the instance the overload occurs, higher current may flow for a very short period of time before the current limit function can react. After the current limit function has tripped (reached the over-current trip threshold), the device switches into current limiting mode and the current is clamped at I_{short} / I_{LIMIT}.
3	Gradual increase from nominal operating current to I_{LIMIT}	Load increases gradually until the current-limit threshold.	The current rises until I_{LIMIT} . Once the threshold has been reached, the device switches into its current limiting mode and is clamped at I_{LIMIT} .

Reverse Current Protection

The USB specification does not allow an output device to source current back into the USB port. In a normal MOSFET switch, current will flow in reverse direction (from the output side to the input side) when the output side voltage is higher than the input side. A **reverse current limit** feature is implemented in the AP2337 to limit such back currents. This circuit is activated by the difference between the output voltage and the input voltage (100mV TYP). After the reverse current circuit has tripped (reached the reverse current trip threshold), the current rises until I_{ROCP} level. When the fault exists for more than 600us, output device is disabled and shutdown. This is called the "Deglitch time from reverse current trigger to MOSFET turn off". Recovery from IROCP occurs when the output voltage falls to 101% of input voltage.

Over-Voltage Protection

The device has an **output over-voltage** protection that triggers when the output voltage reaches 114% (TYP) of input voltage. When this fault condition stays on for longer than 15us (This is called the "Debounce time from output over-voltage to MOSFET turn off") output device is disabled and shutdown. Recovery from ROVP occurs when the output voltage falls to 101% of input voltage.

Application Note (cont.)

Thermal Protection

Thermal protection prevents the IC from damage when the die temperature exceeds safe margins. This mainly occurs when heavy-overload or short-circuit faults are present for extended periods of time. The AP2337 implements a thermal sensing to monitor the operating junction temperature of the power distribution switch. Once the die temperature rises to approximately 150°C, the Thermal protection feature gets activated as follows: The internal thermal sense circuitry turns the power switch off thus preventing the power switch from damage. Hysteresis in the thermal sense circuit allows the device to cool down to approximately 20°C before the output is turned back on. This built-in thermal hysteresis feature is an excellent feature, as it avoids undesirable oscillations of the thermal protection circuit. The switch continues to cycle in this manner until the load fault is removed, resulting in a pulsed output.

Discharge Function

When input voltage is pulled, the discharge function is active. The output capacitor is discharged through an internal NMOS that has a discharge resistance of 100Ω. Hence, the output voltage drops down to zero. The time taken for discharge is dependent on the RC time constant of the resistance and the output capacitor. Discharge time is calculated when UVLO falling threshold is reached to output voltage reaching 300mV.

Power Dissipation and Junction Temperature

The low on-resistance of the internal MOSFET allows the small surface-mount packages to pass large current. Using the maximum operating ambient temperature (T_A) and R_{DS(ON)}, the power dissipation can be calculated by:

$$P_D = R_{DS(ON)} \times I^2$$

Finally, calculate the junction temperature:

$$T_J = P_D \times R_{\theta JA} + T_A$$

Where:

T_A = Ambient temperature °C

R_{θJA} = Thermal resistance

P_D = Total power dissipation

Ordering Information

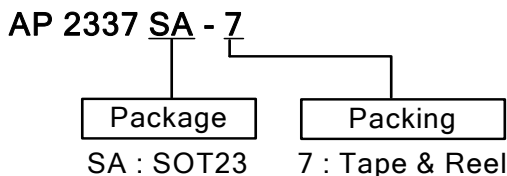

Device	Package Code	Packaging (Note 7)	7" Tape and Reel	
			Quantity	Part Number Suffix
AP2337SA-7	SA	SOT23	3000/Tape & Reel	-7

Notes: 7. Pad layout as shown on Diodes Inc. suggested pad layout document AP02001, which can be found on our website at <http://www.diodes.com/datasheets/ap02001.pdf>.

Marking Information

(Top View)

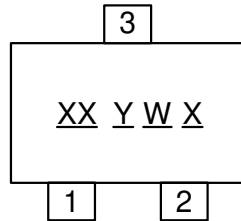

XX : Identification code
Y : Year 0~9
W : Week : A~Z : 1~26 week;
a~z : 27~52 week; z represents
52 and 53 week
X : A~Z : Internal code

Device	Package	Identification Code
AP2337SA-7	SOT23	KM

Package Outline Dimensions

SOT23

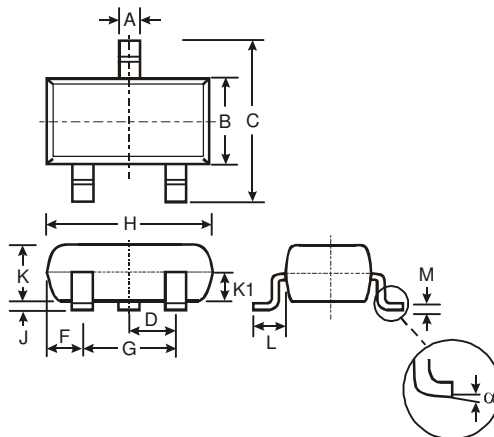

SOT23			
Dim	Min	Max	Typ
A	0.37	0.51	0.40
B	1.20	1.40	1.30
C	2.30	2.50	2.40
D	0.89	1.03	0.915
F	0.45	0.60	0.535
G	1.78	2.05	1.83
H	2.80	3.00	2.90
J	0.013	0.10	0.05
K	0.903	1.10	1.00
K1	-	-	0.400
L	0.45	0.61	0.55
M	0.085	0.18	0.11
α	0°	8°	-

All Dimensions in mm

IMPORTANT NOTICE

DIODES INCORPORATED MAKES NO WARRANTY OF ANY KIND, EXPRESS OR IMPLIED, WITH REGARDS TO THIS DOCUMENT, INCLUDING, BUT NOT LIMITED TO, THE IMPLIED WARRANTIES OF MERCHANTABILITY AND FITNESS FOR A PARTICULAR PURPOSE (AND THEIR EQUIVALENTS UNDER THE LAWS OF ANY JURISDICTION).

Diodes Incorporated and its subsidiaries reserve the right to make modifications, enhancements, improvements, corrections or other changes without further notice to this document and any product described herein. Diodes Incorporated does not assume any liability arising out of the application or use of this document or any product described herein; neither does Diodes Incorporated convey any license under its patent or trademark rights, nor the rights of others. Any Customer or user of this document or products described herein in such applications shall assume all risks of such use and will agree to hold Diodes Incorporated and all the companies whose products are represented on Diodes Incorporated website, harmless against all damages.

Diodes Incorporated does not warrant or accept any liability whatsoever in respect of any products purchased through unauthorized sales channel.

Should Customers purchase or use Diodes Incorporated products for any unintended or unauthorized application, Customers shall indemnify and hold Diodes Incorporated and its representatives harmless against all claims, damages, expenses, and attorney fees arising out of, directly or indirectly, any claim of personal injury or death associated with such unintended or unauthorized application.

Products described herein may be covered by one or more United States, international or foreign patents pending. Product names and markings noted herein may also be covered by one or more United States, international or foreign trademarks.

LIFE SUPPORT

Diodes Incorporated products are specifically not authorized for use as critical components in life support devices or systems without the express written approval of the Chief Executive Officer of Diodes Incorporated. As used herein:

A. Life support devices or systems are devices or systems which:

1. are intended to implant into the body, or
2. support or sustain life and whose failure to perform when properly used in accordance with instructions for use provided in the labeling can be reasonably expected to result in significant injury to the user.

B. A critical component is any component in a life support device or system whose failure to perform can be reasonably expected to cause the failure of the life support device or to affect its safety or effectiveness.

Customers represent that they have all necessary expertise in the safety and regulatory ramifications of their life support devices or systems, and acknowledge and agree that they are solely responsible for all legal, regulatory and safety-related requirements concerning their products and any use of Diodes Incorporated products in such safety-critical, life support devices or systems, notwithstanding any devices- or systems-related information or support that may be provided by Diodes Incorporated. Further, Customers must fully indemnify Diodes Incorporated and its representatives against any damages arising out of the use of Diodes Incorporated products in such safety-critical, life support devices or systems.

Copyright © 2011, Diodes Incorporated

www.diodes.com